

FLEXTOOL TUFFTRUK[®] EB500 - ELECTRIC

Flextool's range of TuffTruk mini dumpers provide maximum versatility and light-touch operation. Available in both battery power and petrol engine, the Flextool TuffTruk achieves ultimate manoeuvrability with its compact size and articulated steering function.

Operator safety is optimised with the 2-stage self-tipping skip and electric motor brake system, while the wide profile mud gripper tyres, excellent load capacity and robust, heavy-duty construction prove the Flextool TuffTruk is designed for all types of materials and tough terrains across a variety of trades.



FLEXTOOL TUFFTRUK® – MINI DUMPERS

Model	EB500	B450G
Max Payload (kg/m ³)	500 / 0.35	450 / 0.3
Operating Width (mm)	850	850
Unladen Operating Weight (kg)	240	180
Working Gradient (deg)	25	25
Drive & Controls	2 x 24 V Transaxle	Hydrostatic
Brake System	Electric	Hydrostatic
Tyres (Standard)	Mud Gripper Pneumatic	Mud Gripper Pneumatic
Travel Speed Fwd / Rev (km/h)	5.6 / 2.4	6.4 / 2.4
Noise level (dB)	< 76	< 96
Hand Arm Vibration (m/s ²)	2.5	4.6
Engine / Motor	DC Brushless	Honda GX200
Engine Motor Power	2 x 750 W / 24 V	6.5 hp
Fuel Type	2 x 12 V AGM Batteries	Petrol
Shipping Dimensions (L x W x H) (mm)	1160 x 940 x 1180	1380 x 920 x 1130
Shipping Weight (kg)	285	220
Product Code	FT202511-UNIT	FT202501-UNIT



EB500



B450G

DIMENSIONS

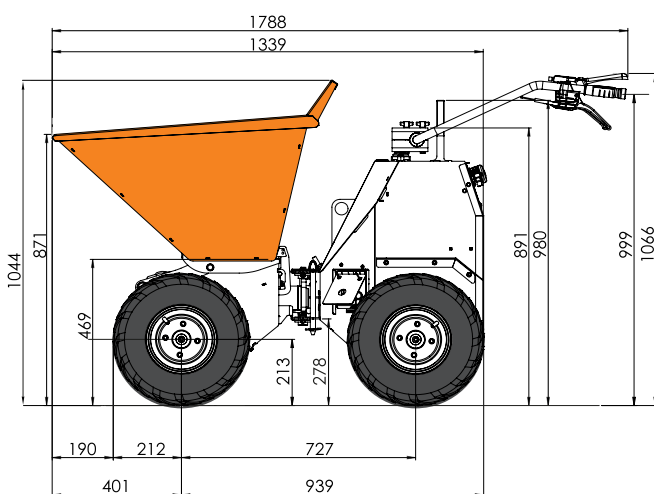

TURNING CIRCLE**

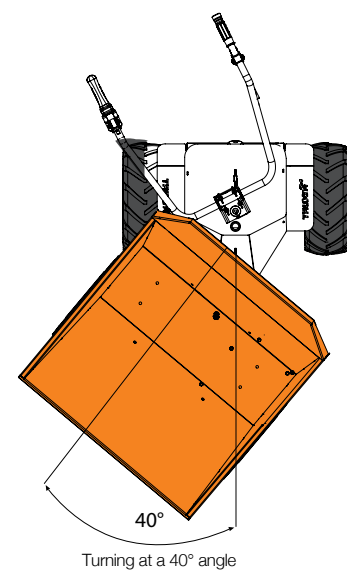

All Dimensions are in millimeters and apply to the EB500 only.

* Denotes dimensions when narrow bucket is fitted.

** Turning circle indicates EB500 only.

FLEXTOL TUFFTRUK® – ACCESSORIES

Description	Suits EB500	Suits B450G	Product Code
1 TUFFTRUK TOW BALL HITCH	✓	✓	FT202504-UNIT
2 TUFFTRUK FLAT BED – 850 MM	✓	✓	FT202505-UNIT
3 TUFFTRUK NARROW POLY BUCKET – 730 MM	✓	✗	FT202512-UNIT
4 TUFFTRUK SKIP CONTROL HANDLE	✓	✓	FT202507-UNIT
5 TUFFTRUK POWERTIP AND BUCKET ATTACHMENT	✓	✗	FT202612-UNIT
6 TUFFTRUK TURF TYRE WHEELS – SET OF 4	✓	✓	FT202509-UNIT

