



# SPARE PARTS MANUAL

## MIKASA TAMPING RAMMER MTX-85DYC



Version 2.0 (March 2022)

FOR MORE INFORMATION  
CONTACT US ON 1300 353 986 OR VISIT [flextool.com.au](http://flextool.com.au)

EXCLUSIVE TO



**TAMPING RAMMER**

**MTX-85DY**

**PARTS LIST**

**305-05301**



---

# PARTS REMARK INDEX

---

## How to read the marks and remarks used in this parts book.

### Section 1 : Explanation of Code Use In “MRK” Column

OO : Interchangeable between the new part and the old one.

XX : Not Interchangeable between new and old.

OX : New part is usable for the old machine but the old part is not usable for the new machine.

XO : The old part is usable for the new machine but the new part is not usable for the old machine.

Note : In case of the lack of interchangeability between the new part and old part, a new part may be used by replacing all other parts found in the assembly. In this case, refer to section 2 for instruction on identifying other parts involved in a new assembly.

AD : Newly established(added)

DC : Suspended(discontinued)

NC : Part number changed

QC : Quantity used has been changed

NS : Not supplied individually but supplied in an assembly or a group.

AS : Special part designed to allow interchangeability between new and old part.

CR : Correction

### Section 2 : Items Found In “Remark” Column

Serial Numbers - Where indicated, this indicates a serial number range (inclusive) where a particular part is used.

Model Number - Where indicated, this shows that the corresponding part is utilized only with this specific model number or model number variant.

# or \* : All parts with the same number following # or \* belong to the same assembly. this part cannot be interchanged individually with any other assemblies to replace an old part (indicated by #), with a new part(indicated by \*), then all other parts of that assembly must be replaced with new ones.

Note : If more than one of the same reference number is listed, the last one listed indicates newest(or latest)part available.

### Section 3: Example

REF NO.	PART NO.	PART NAME	QTY	MRK	REMARKS
457(1)	5122-09230	Hinge Metal, Upper/24g	1		-1070 #3 (5)
457(2)	5072-09420	Hinge Metal, Upper M16	1	OX(3)	U1071-(6) * 3(7)

(1) Old part

(2) New part

(3) New part usable with old machine, but old part not usable with new machine (reference section 1).

(4) Old part number is used through this machine serial number.

(5) Old part, used in an assembly with other parts marked with #3. To use this part on a new machine, all other parts in this assembly must be replaced with old ones.

(6) New part put into use starting with this serial number and is still current.

(7) New part used in an assembly with other parts marked \* 3, to use this part as a replacement for an old part, all other \* 3 marked parts must be changed at the same time.

### Section 4: Items Found In “MK2” Column

(only for suspended products)

! OO (“OO” is shown in figure) : The part shown in lower line is supplied.

! SD : Not available due to termination of production.

! NS : Not supplied individually, but supplied in an assembly or a group.

! PD : Supplied as unit product.

SS : Not available after stock run out.

(The contents of this parts catalog are subject to change without notice.)

# MTX-85DY CRANK CASE,ENGINE

30X0

## CLUTCH

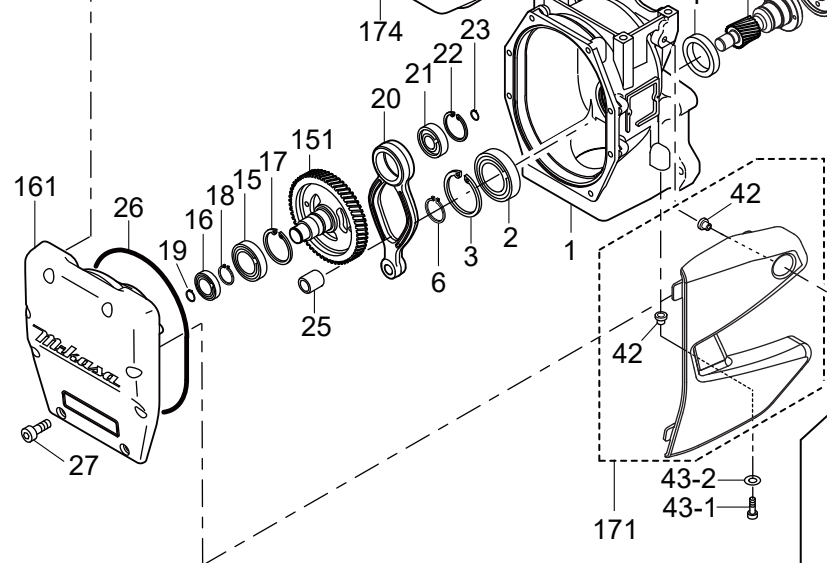
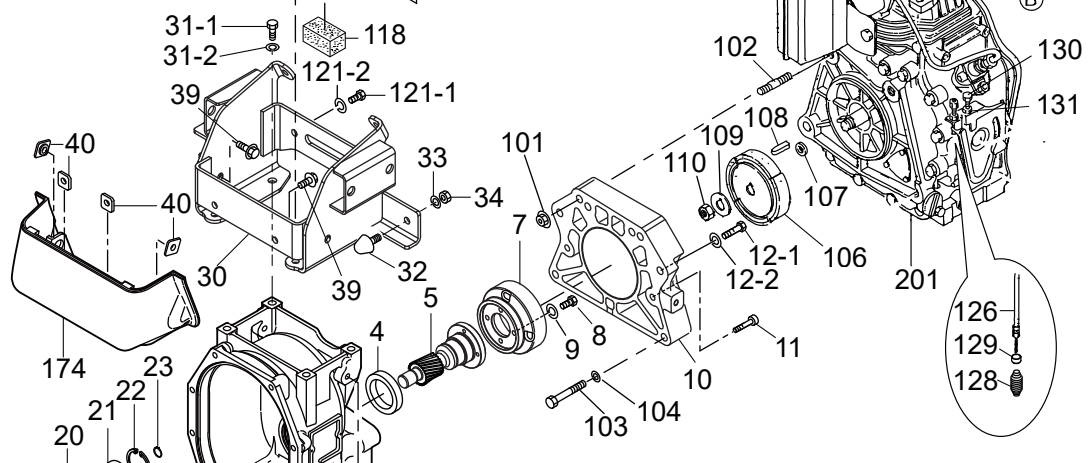
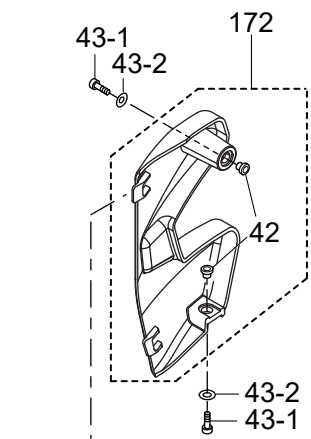
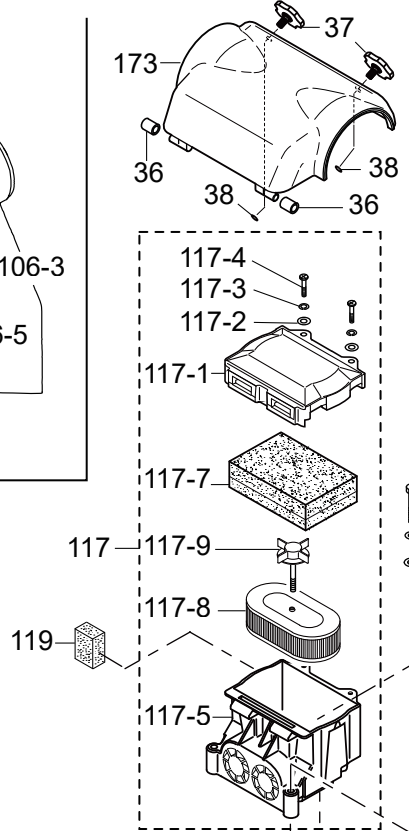
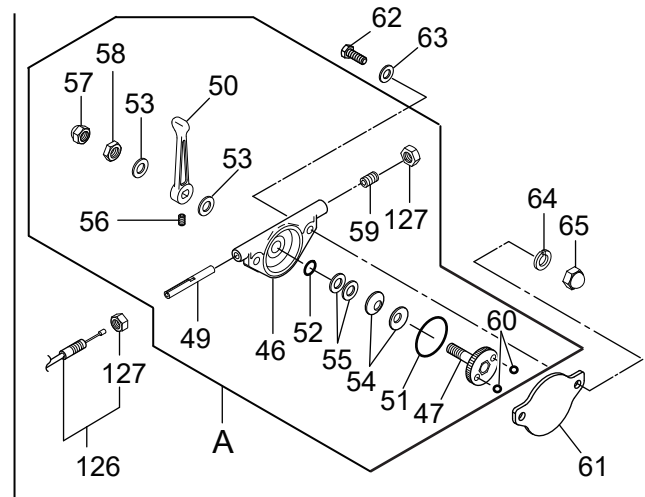
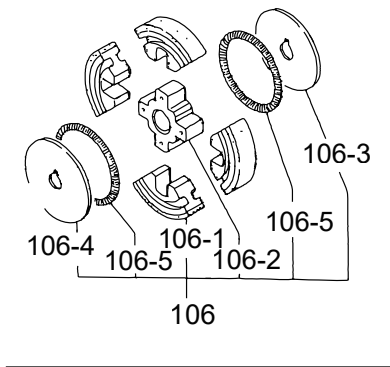

## PROTECTOR

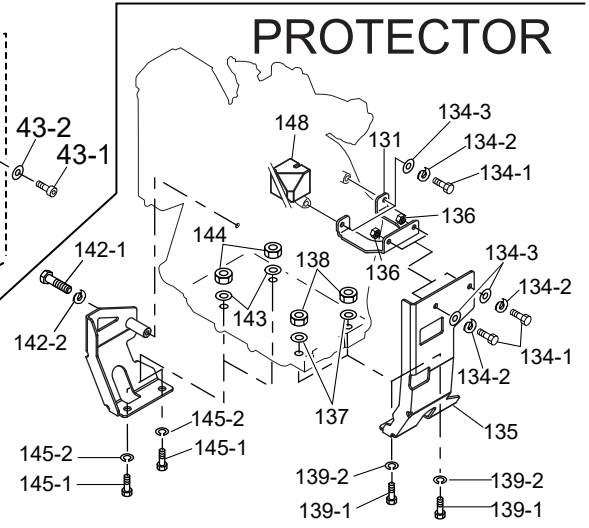

# MTX-85DY

2019/5/28

## CRANKCASE, ENGINE

\*\* 30X \*\*

REF NO.	PART NO.	PART NAME	Q' TY	MRK	MK2	REMARKS
A	3629-10220	THROTTLE LEVER AY /MTX-85DY	1			
1	3661-18940	CRANK CASE / MTX-80	1			
2	0410-06007	BEARING 6007Z	1			
3	0801-00620	STOP RING R-62	1			
4	0604-04010	OIL SEAL TC-40528	1			
5	3703-55790	PINION /MTX-85DY	1			
6	0802-00350	STOP RING S-35	1			
7	3704-70830	CLUTCH DRUM /MTX-85DY	1			
8	0012-20615	BOLT 6X15 T	4			
9	0302-06150	SW M6	4			
10	3701-22490	ENGINE FRANGE /MTX-85DY	1			
11	0091-10052	SOCKET HEAD BOLT 8X45 ZN	2			
12 -1	0012-21040	BOLT 10X40 T	2			
12 -2	0302-10250	SW M10	2			
15	0400-06207	BEARING 6207	1			
16	0400-06305	BEARING 6305	1			
17	0801-00720	STOP RING R-72	1			
18	0802-00350	STOP RING S-35	1			
19	0802-00250	STOP RING S-25	1			
20	3703-55800	CONNECTING ROD /MTX-85DY	1			
21	0400-06304	BEARING 6304	1			
22	0801-00520	STOP RING R-52	1			
23	0802-00200	STOP RING S-20	1			
25	0479-40060	NEEDLE BEARING FJ-1816	1			
26	0507-10080	O-RING AS568-267	1			
27	0015-20825	SOCKET HEAD BOLT 8X25 T	8			
30	3702-19980	BRACKET, SHOCK ABSORBER	1			
31 -1	0012-21030	BOLT 10X30 T	4			
31 -2	0302-10250	SW M10	4			
32	9390-10270	STOPPER RUBBER ( 70 ) /MT	1			
33	0302-08200	SW M8	1			
34	0203-08060	NUT M8	1			
36	3664-60140	RUBBER BUSH (10X16X17)	2			
37	3663-45980	KNOB, CLEANER COVER / MTX	2		SX	
38	0502-00060	O-RING P6	2			
39	0091-10040	FLANGE BOLT 8X20	4			
40	9594-07670	SQUARE NUT M8	4			
42	3664-61050	COLLAR / GUARD	4			
43 -1	0015-20820	SOCKET HEAD BOLT 8X20 T	4			
43 -2	0339-10220	WASHER (8. 4X15. 5X1. 6)	4			
46	3623-41550	THROTTLE BODY /MT-55	1			
47	3629-10230	THROTTLE, GEAR CP, W/BOLT	1			
49	3624-55620	SLIDER /MT-55	1			
50	3624-55630	THROTTLE LEVER /MT-55	1			
51	0501-00450	O-RING G-45	1			
52	0502-00100	O-RING P-10	1			
53	0311-10160	PW M10	2			
54	0321-10180	CONICAL SPRING WASHER M10	2			
55	9524-09100	WASHER 10. 5X22X0. 1	2			
56	0962-06006	SOCKET HEAD SCREW 6X6	1			
57	0221-31008	CAP NUT M10	1			
58	0204-10060	NUT M10, H=6	1			
59	0962-08020	SOCKET HEAD SCREW 8X20	1			
60	4644-57440	STEEL BALL D6(SUJ)	2			
61	3714-67640	IDLE NOTCH PLATE	1			
62	0012-20625	BOLT 6X25 T	2			
63	0311-06100	PW M6	2			
64	0302-06150	SW M6	2			
65	0221-30605	CAP NUT M6	2			
101	0226-11010	FLANGE NUT M10 H	2			

# MTX-85DY CRANK CASE,ENGINE

30X0

## CLUTCH

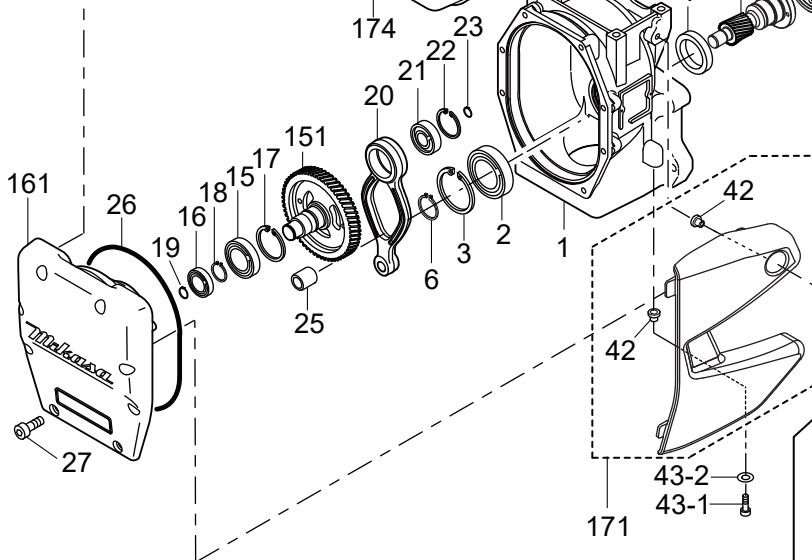
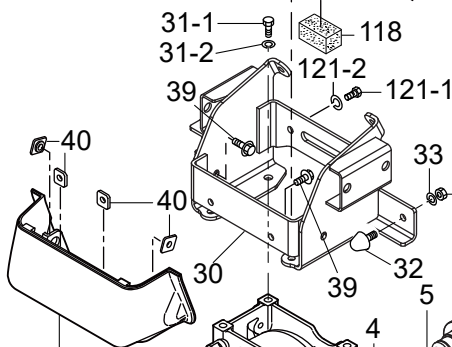
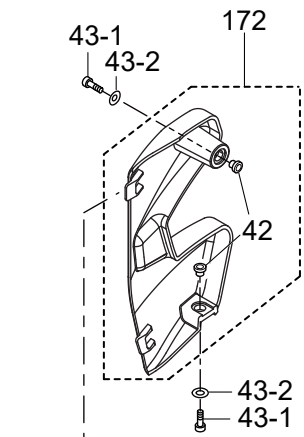
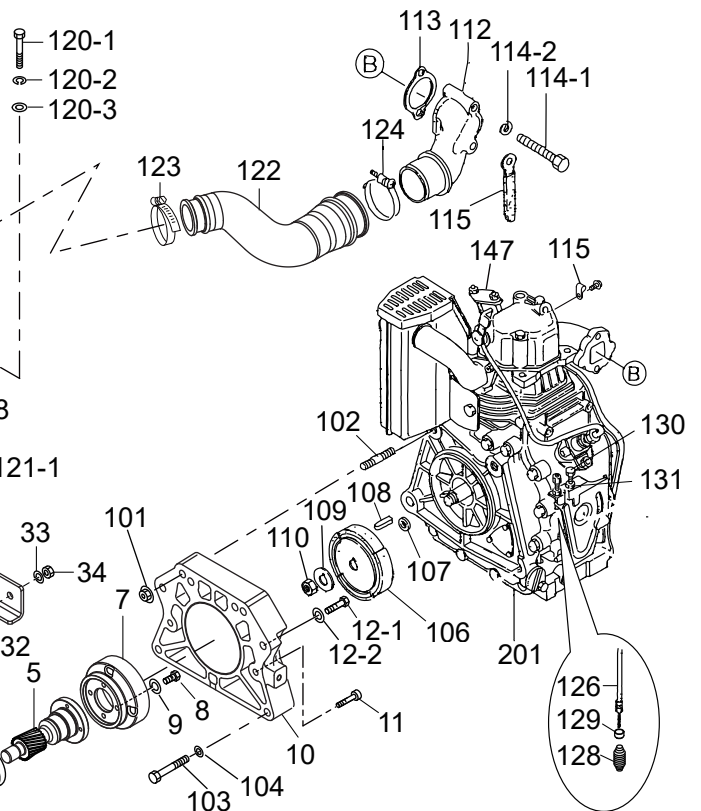
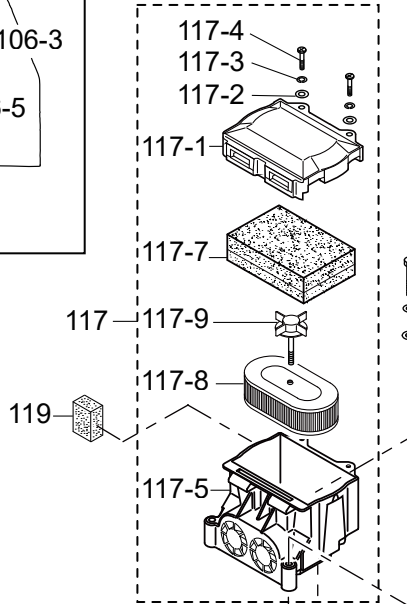
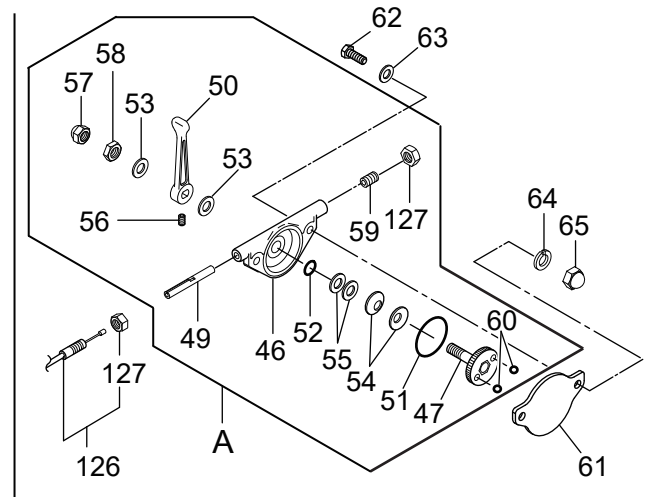
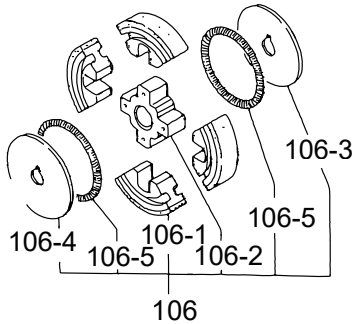

## PROTECTOR

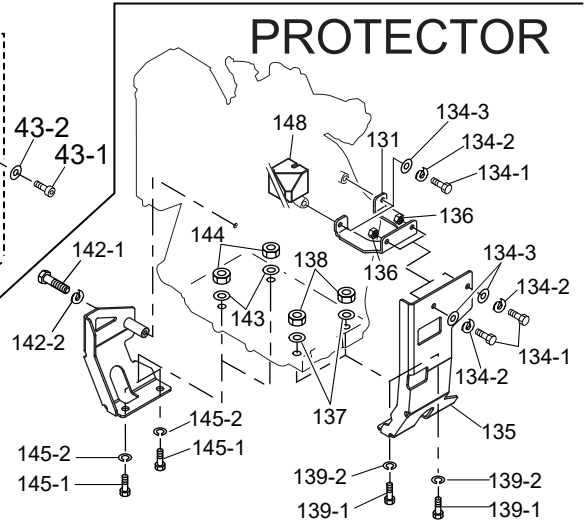

**MTX-85DY**

2019/5/28

**CRANKCASE, ENGINE**

**\*\* 30X \*\***

REF NO.	PART NO.	PART NAME	Q' TY	MRK	MK2	REMARKS
102	0091-20207	STUD BOLT 10X55	2			
103	0012-21058	BOLT 10X90 T	2			
104	0302-10250	SW M10	2			
106	3714-63850	CLUTCH AY/CF050B/MT-D	1			
106 -1	9430-20060	CLUTCH SHOE CP	4			
106 -2	9430-50050	CLUTCH BOSS C812	1		!SD	
106 -3	9430-60100	CLUTCH GAIDE/(A) 1. 6T, 1C	1			
106 -4	9430-60020	CLUTCH GUIDE/B	1			
106 -5	9430-30021	CLUTCH SPRING	2			
107	3714-48260	SPACER 15X24X4 /MT76D, 86D	1			
108	22512-040120	KEY 4X 12	1			
109	3010-10210	LOCK WASHER, CLUTCH	1			
110	0229-10170	NUT M12 (P1. 25-B17)	1			
112	3713-35270	INTAKE FLANGE /MT-76D, 86D	1			
113	114284-12200	GASKET, AIR INTAKE	1			
114 -1	0012-20652	BOLT 6X60 T	2			
114 -2	0302-06150	SW M6	2			
115	9540-10310	CODE CLAMP	2			
117	3661-18640	AIR CLERNER AY / MTX	1			
117 -1	3660-10010	AIR CLEANER COVER / MTX	1			
117 -2	3660-10020	PW M6 (6. 5X18X1. 5)	2			
117 -3	0302-06150	SW M6	2			
117 -4	3660-10330	COIN BOLT M6 W/SW, PW	2			
117 -5	3660-10050	BASE CP, AIR CLEANER/MTX	1			
117 -7	3660-10070	PRIMARY ELEMENT CP /MTX	1			
117 -8	3660-10080	SECONDARY ELEMENT/MTX	1			
117 -9	3620-30040	GRIP BOLT CP, AIR CLERNER	1			
118	3664-60160	SEALING FORM, UNDER / MTX	1			
119	3664-60150	SEALING FORM, SIDE / MTX	1			
120 -1	0012-20851	BOLT 8X55 T	2			
120 -2	0302-08200	SW M8	2			
120 -3	0311-08160	PW M8	2			
121 -1	0012-20815	BOLT 8X15 T	2			
121 -2	0302-08200	SW M8	2			
122	3703-55780	INTAKE PIPE /MTX-85DY	1			
123	9544-07682	CYCLONE CLAMP (CY-1) 38	1			
124	3710-00020	HOSE BAND (B) AH-1050	1			
126	9561-00057	THROTTLE WIRE V390-510	1			
127	0204-08050	NUT M8, H=5	2			
128	3714-67760	RETURN SPRING /MT-76D	1			
129	3714-67770	RUBBER CAP (THROTTLE LEVER	1			
130	114250-66440	BOLT, ADJUSTING	1			
131	26756-060002	LOCK NUT M 6 PLATED	1			
133	3704-70840	LINK PROTECTOR STAY /85DY	1			
134 -1	0012-20620	BOLT 6X20 T	4			
134 -2	0302-06150	SW M6	4			
134 -3	0311-06100	PW M6	4			
135	3702-19990	LINK PROTECTOR /MTX-85DY	1			
136	0203-06050	NUT M6	2			
137	0311-10160	PW M10	2			
138	0203-10080	NUT M10	2			
139 -1	0012-21040	BOLT 10X40 T	2			
139 -2	0302-10250	SW M10	2			
141	3703-55810	MUFFLER PROTECTOR /85DY	1			
142 -1	0012-20651	BOLT 6X55 T	1			
142 -2	0302-06150	SW M6	1			
143	0311-10160	PW M10	2			
144	0203-10080	NUT M10	2			
145 -1	0012-21040	BOLT 10X40 T	2			
145 -2	0302-10250	SW M10	2			



# MTX-85DY CRANK CASE,ENGINE

30X0

## CLUTCH

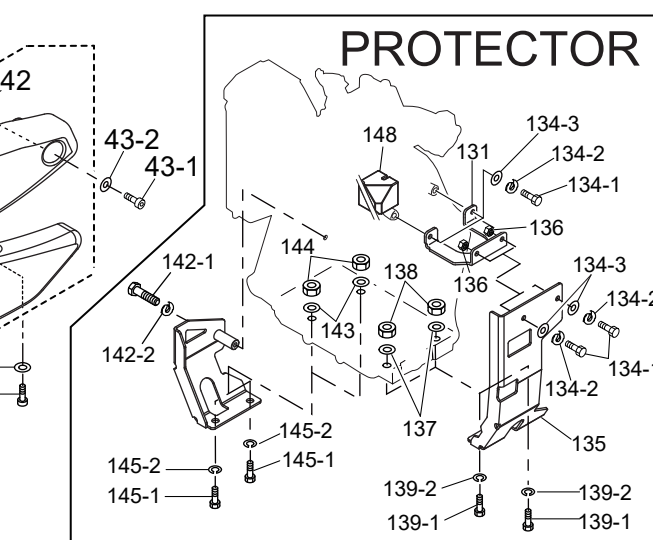
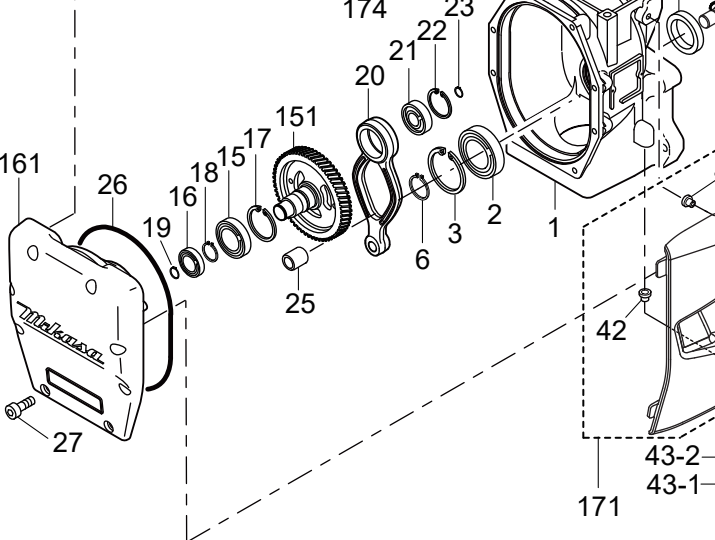
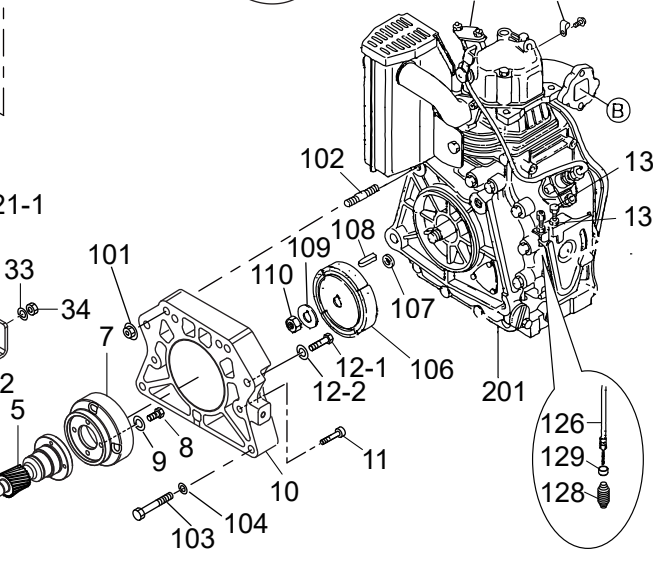
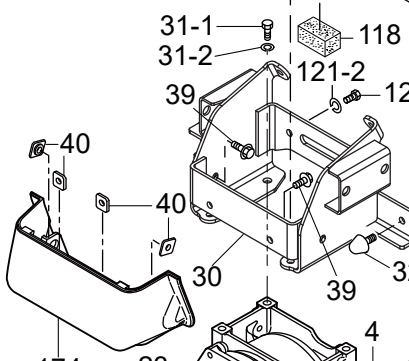
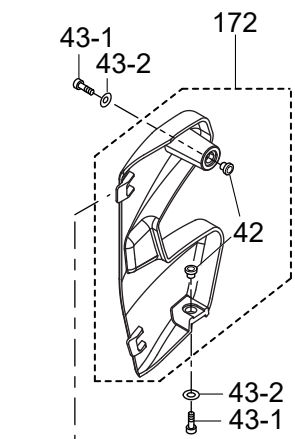
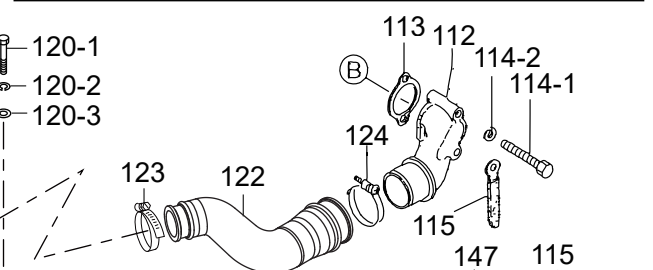
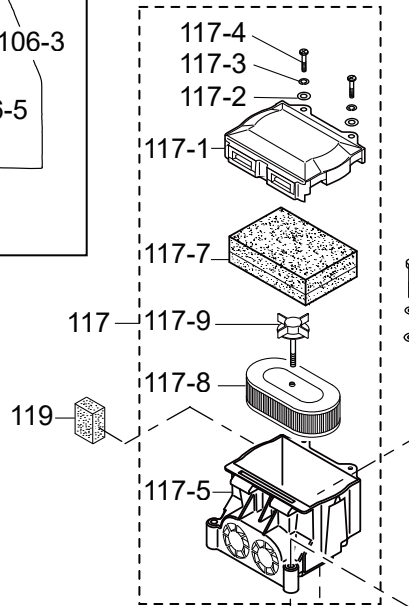
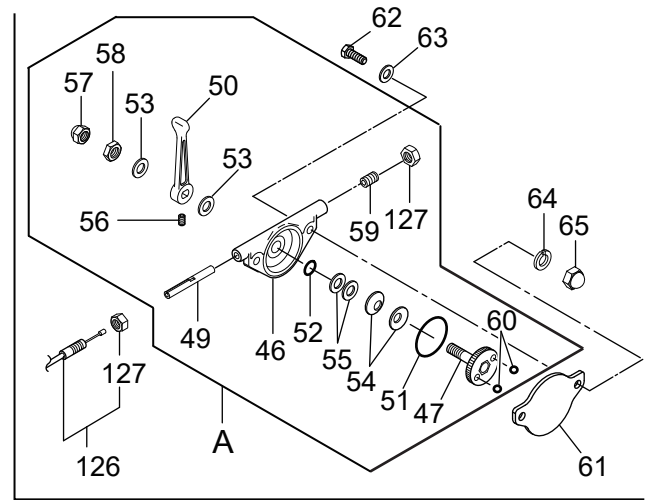
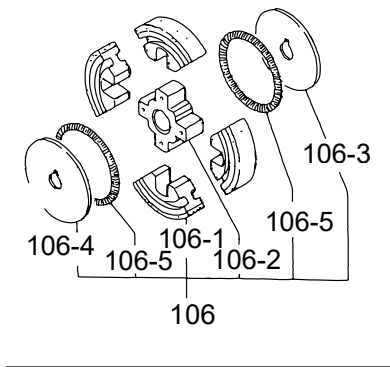



MTX-85DY  
FUEL TANK, HANDLE

30Y0

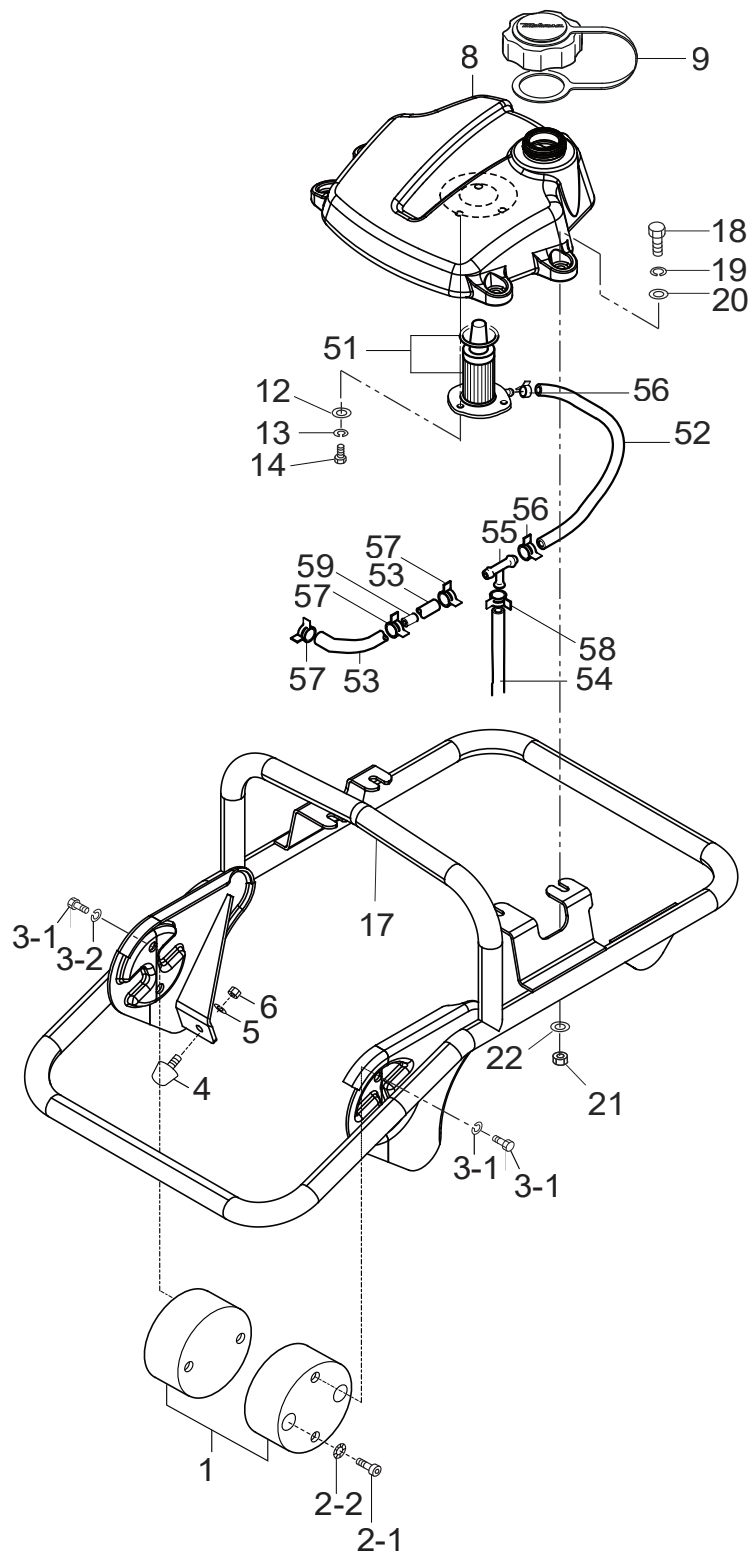



MTX-85DY

30Z0

SPRING CYLINDER, GUIDE CYLINDER

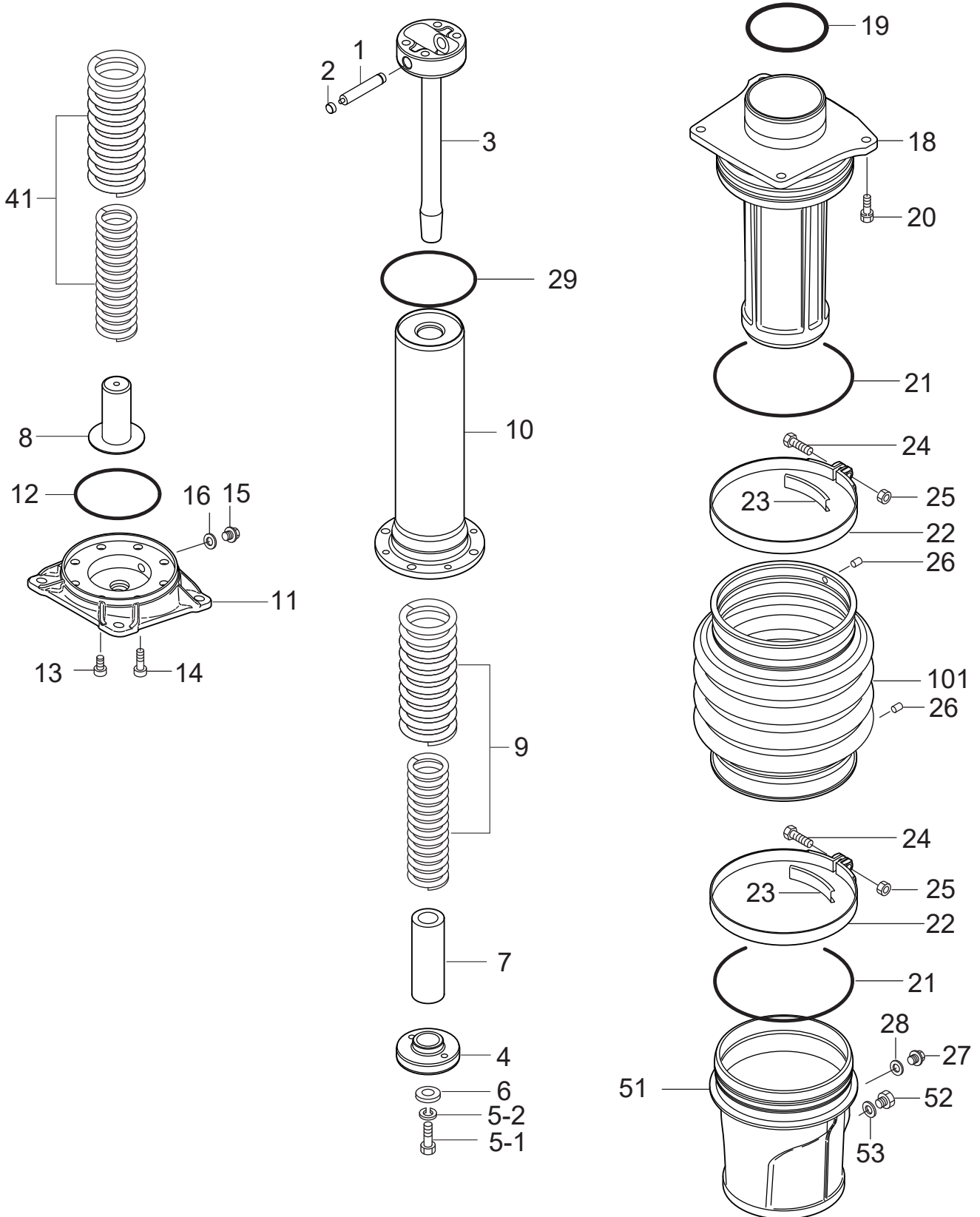



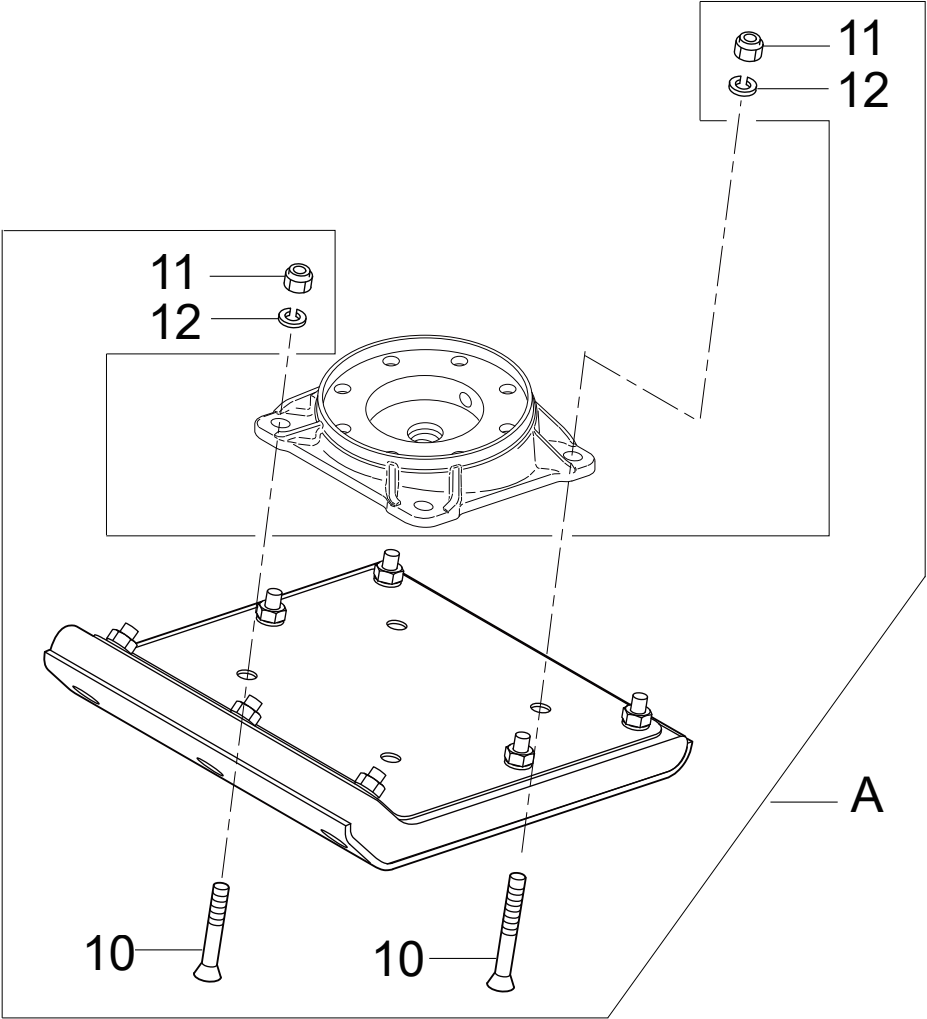





LEFT SIDE VIEW

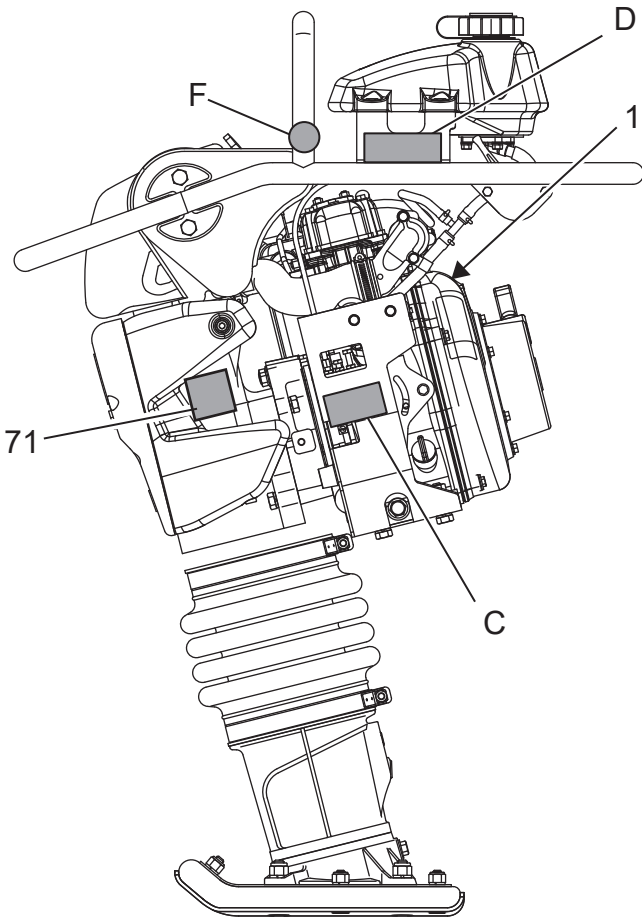

FRONT VIEW

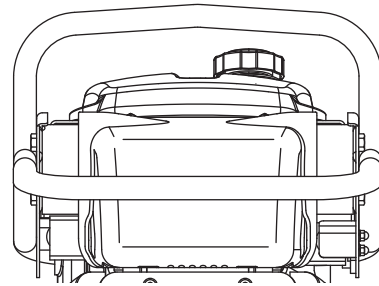

TOP VIEW

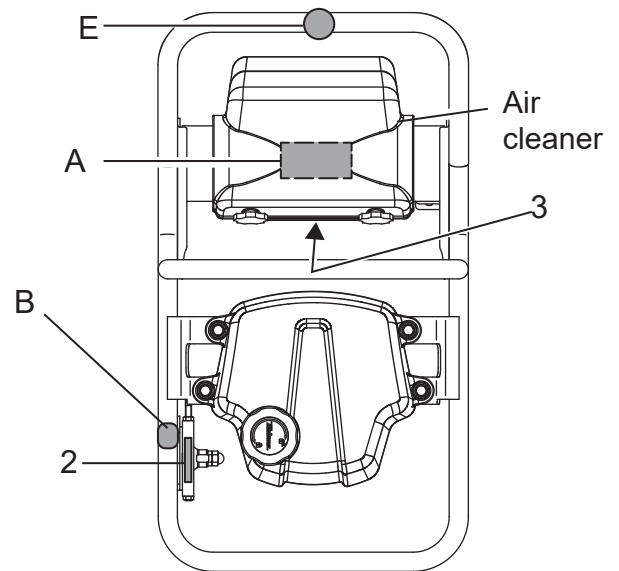

101

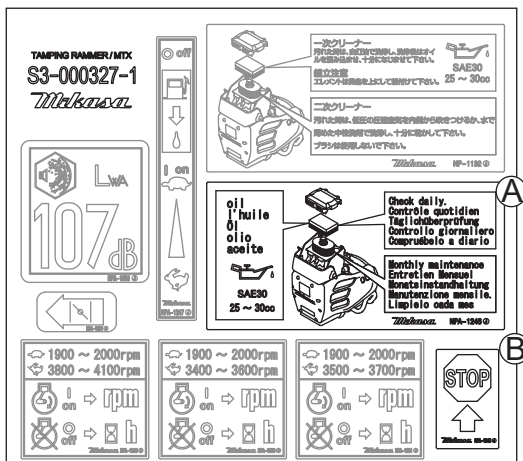

102

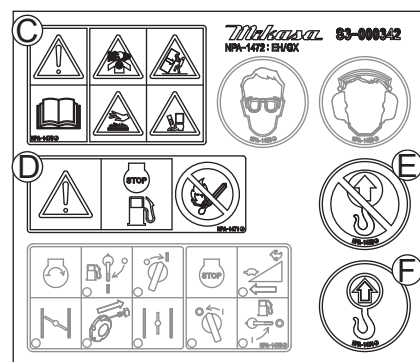



*Mikasa*



## **Parchem Construction Supplies Pty Ltd**

1956 Dandenong Road, Clayton VIC 3168, Australia

Phone: 1300 353 986

[flextool.com.au](http://flextool.com.au)

ABN 80 069 961 968

This manual summarises our best knowledge of the product based on the information available at the time of publication. You should read this manual carefully and consider the information in the context of how the product will be used. Our responsibility for products sold is subject to our standard terms and conditions of sale.

### DISCLAIMER:

Any advice, recommendation, information, assistance or service provided by us in this manual is given in good faith and is believed by us to be appropriate and reliable. However, any advice, recommendation, information, assistance or service provided by us is provided without liability or responsibility PROVIDED THAT the foregoing shall not exclude, limit, restrict or modify the right entitlements and remedies conferred upon any person or the liabilities imposed upon us by any condition or warranty implied by Commonwealth, State or Territory Act or ordinance void or prohibiting such exclusion limitation or modification. The product can be expected to perform as indicated in this manual so long as operation and operational procedures of the individual products are followed as recommended in this manual.

Design and technical specifications may be subject to changes.

© This publication is copyright. All rights are reserved. Flextool is a registered trade mark of Parchem Construction Supplies Pty Ltd. Mikasa is a registered trade mark of Mikasa Sangyo Co. Ltd, used under licence.

**FOR MORE INFORMATION**  
CONTACT US ON **1300 353 986** OR VISIT [flextool.com.au](http://flextool.com.au)

**EXCLUSIVE TO**

