



SPARE PARTS MANUAL

FLEXTOOL TUFFTRUK™ EB500



Version 1.0 (November 2022)

FOR MORE INFORMATION
CONTACT US ON **1300 353 986** OR VISIT flextool.com.au

Flextool TuffTruk EB500 Mini Dumper

Explanation Of Code In Remarks Column.....	4
Suggested Spare Parts	5

Component Drawings

Nameplate And Decals Assembly	6–7
Handlebar Assembly	8–9
Steering Column Assembly	10–11
Center Steering Assembly.....	12–13
Front Chassis Assembly	14–15
Rear Chassis Assembly	16–17
Back Panel Assembly	18–19
Tub Mount And Latch Assembly	20–21
Battery Assembly.....	22–23
Junction Box/Controller Assembly	24–25
Power/Gnd Cable Assembly	26–27
Harness Assembly.....	28–29
Tub Tipping Handle Assembly (Option)	30–31
Tub Extension Assembly (Option)	32–33
Tow Hitch Assembly (Option)	34–35
Flatbed Assembly (Option)	36–37
Flatbed Load Stop Assembly (Option).....	38–39

NOTICE

Specifications are subject to change without notice.

EXPLANATION OF CODE IN REMARKS COLUMN

The following section explains the different symbols and remarks used in the Parts section of this manual. Use the help numbers found on the back page of the manual if there are any questions.

NOTICE

The contents and part numbers listed in the parts section are subject to change **without notice**. Flextool does not guarantee the availability of the parts listed.

SAMPLE PARTS LIST

NO.	PART NO.	PART NAME	QTY.	REMARKS
1	12345	BOLT	1	INCLUDES ITEMS W/%
2%		WASHER, 1/4 IN.		NOT SOLD SEPARATELY
2%	12347	WASHER, 3/8 IN. ...	1	45T ONLY
3	12348	HOSE	A/R	MAKE LOCALLY
4	12349	BEARING	1	S/N 2345B AND ABOVE

NO. Column

Unique Symbols — All items with same unique symbol (@, #, +, %, or >) in the number column belong to the same assembly or kit, which is indicated by a note in the “Remarks” column.

Duplicate Item Numbers — Duplicate numbers indicate multiple part numbers, which are in effect for the same general item, such as different size saw blade guards in use or a part that has been updated on newer versions of the same machine.

NOTICE

When ordering a part that has more than one item number listed, check the remarks column for help in determining the proper part to order.

PART NO. Column

Numbers Used — Part numbers can be indicated by a number, a blank entry, or TBD.

TBD (To Be Determined) is generally used to show a part that has not been assigned a formal part number at the time of publication.

A blank entry generally indicates that the item is not sold separately or is not sold by Flextool. Other entries will be clarified in the “Remarks” Column.

QTY. Column

Numbers Used — Item quantity can be indicated by a number, a blank entry, or A/R.

A/R (As Required) is generally used for hoses or other parts that are sold in bulk and cut to length.

A blank entry generally indicates that the item is not sold separately. Other entries will be clarified in the “Remarks” Column.

REMARKS Column

Some of the most common notes found in the “Remarks” Column are listed below. Other additional notes needed to describe the item can also be shown.

Assembly/Kit — All items on the parts list with the same unique symbol will be included when this item is purchased.

Indicated by:

“INCLUDES ITEMS W/(unique symbol)”

Serial Number Break — Used to list an effective serial number range where a particular part is used.

Indicated by:

“S/N XXXXX AND BELOW”
 “S/N XXXX AND ABOVE”
 “S/N XXXX TO S/N XXX”

Specific Model Number Use — Indicates that the part is used only with the specific model number or model number variant listed. It can also be used to show a part is NOT used on a specific model or model number variant.

Indicated by:

“XXXXX ONLY”
 “NOT USED ON XXXX”

“Make/Obtain Locally” — Indicates that the part can be purchased at any hardware shop or made out of available items. Examples include battery cables, shims, and certain washers and nuts.

“Not Sold Separately” — Indicates that an item cannot be purchased as a separate item and is either part of an assembly/kit that can be purchased, or is not available for sale through Flextool.

SUGGESTED SPARE PARTS

FLEXTOOL TUFFTRUK EB500 MINI DUMPER

1 to 3 units

Qty.	P/N	Description
3.....	70-0188	FUSE, 10A IGNITION, RED
3.....	70-0188	FUSE, 10A AUX 1, RED
3.....	70-0188	FUSE, 10A AUX 2, RED
3.....	70-0189	FUSE, 20A PTO. YELLOW
3.....	70-0183	FUSE, 100A CONTROLLER
3.....	70-0140	5K OHM POT.
3.....	70-01405SP.....	5K OHM POT. W/LEADS
3.....	70-0128	SOLENOID, 24 VDC
1.....	70-0127	EMERG. STOP SWITCH
1.....	70-0134	BATTERY CHARGER
1.....	60-6609RHF	WHEEL RIGHT-SIDE F/R
1.....	60-6609LHF.....	WHEEL LEFT-SIDE F/R
2.....	70-8003-0	IGNITION SW W/KEYS
2.....	75-02700	LEVER/CABLE ASSY., DM
2.....	75-02600	LEVER/CABLE ASSY., F
2.....	75-02100	LEVER ASSY., REV.
4.....	74-1022	GRIP, HANDLE BAR
2.....	2-1400-0	STEERING DAMPNER
2.....	105-09800	STEERING ROD ASSY.

NOTICE

Part numbers on this Suggested Spare Parts list may supersede/replace the part numbers shown in the following parts lists.

NAMEPLATE AND DECALS ASSY.

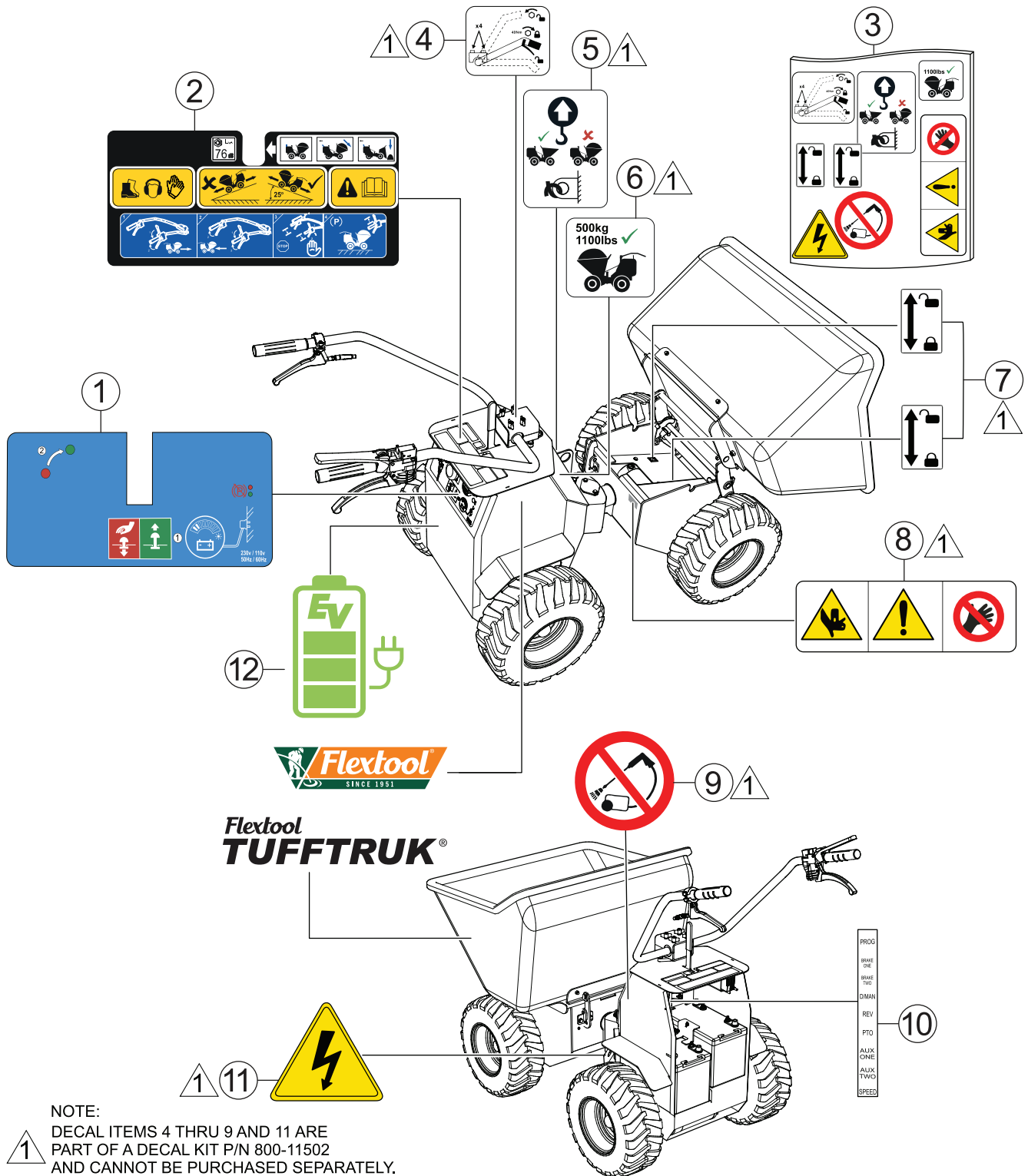

NAMEPLATE AND DECALS ASSY.

<u>NO.</u>	<u>PART NO.</u>	<u>PART NAME</u>	<u>QTY.</u>	<u>REMARKS</u>
1	800-17501	DECAL: EMERG. STOP/BATTERY CHARGE	1	
2	800-17502	DECAL: OPERATION INSTRUCTION	1	
3	800-11502	DECAL: KIT, DECAL.....	1.....	INCLUDES ITEMS W/#
4#		DECAL: HANDLE ATTACHMENT	1	
5#		DECAL: LIFTING POINT	1	
6#		DECAL: LOAD CAPACITY 1100 LB. (500KG)	1	
7#		DECAL: LOCK/UNLOCK TUB	2	
8#		DECAL: WARNING	1	
9#		DECAL: DO NOT SPRAY ELECT. COMPONENTS	1	
10	800-17506	DECAL: JUNCTION BOX PORTS	1	
11#		DECAL: ELECTRICAL SHOCK HAZARD	1	
12	800-15070	DECAL: EV LOGO	1	

HANDLEBAR ASSY.

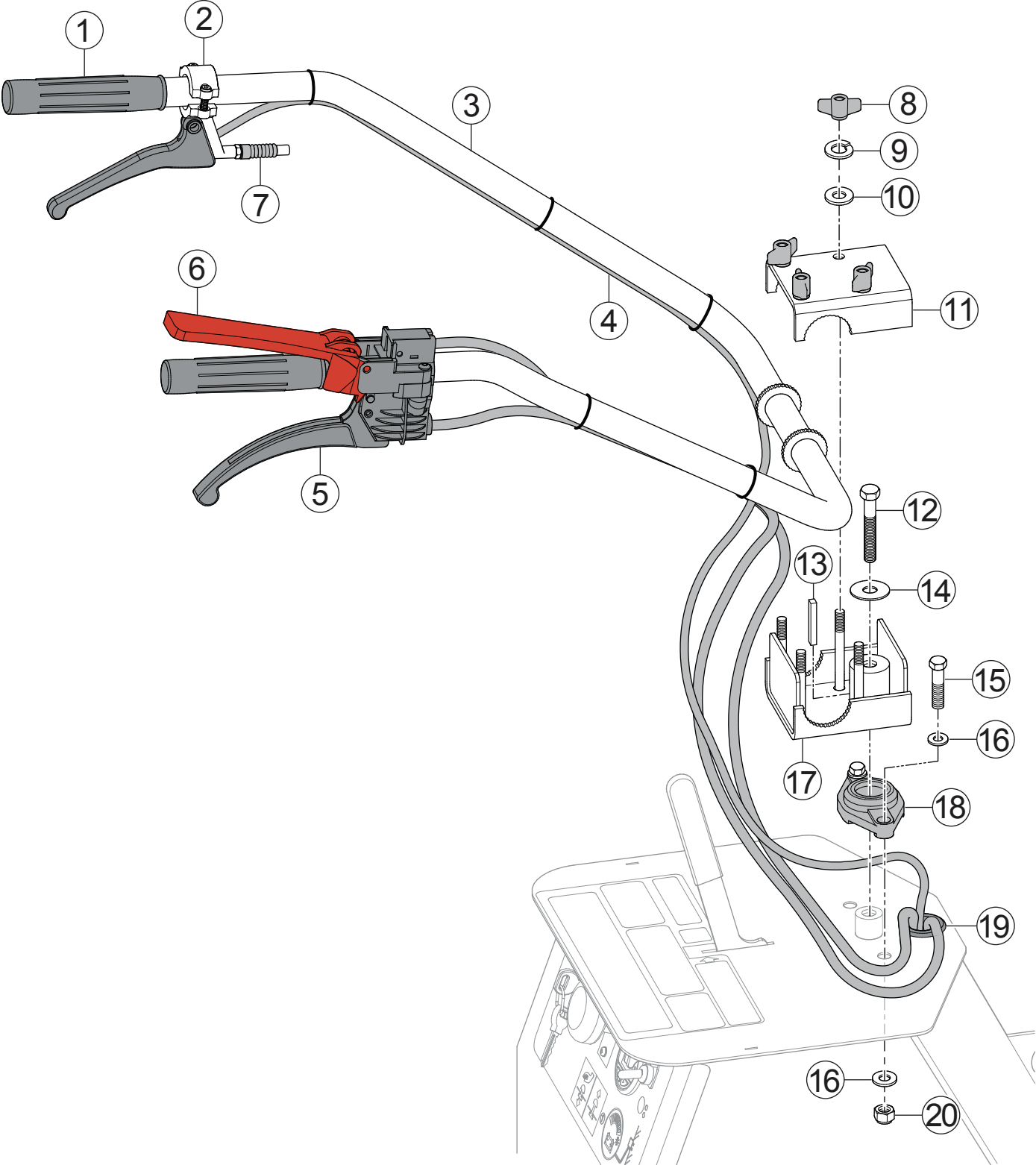

HANDLEBAR ASSY.

<u>NO.</u>	<u>PART NO.</u>	<u>PART NAME</u>	<u>QTY.</u>	<u>REMARKS</u>
1	74-1022	HANDLE, GRIP	2	
2	75-02100	LEVER ASSY., REVERSE.....	1.....	INCLUDES ITEMS W/#
3	105-10400	HANDLEBAR	1	
4#		CABLE REV. H/BARSW./CTRLR MOLEX END	1	
5	75-02600	LEVER/CABLE ASSY., FORWARD	1	
6	75-02700	LEVER/CABLE ASSY., DEADMAN	1	
7#		HEAT SHRINK 15MM X 1.2M	1	
8	8-8118	WING NUT, M8	4	
9	4-8003	WASHER, M8 SPRING	4	
10	4-8006	WASHER, M8	4	
11	105-99974	STEERING CLAMP UPPER	1	
12	7-10005	SCREW SET M10 X 25	1	
13	21-1201	SQUARE KEY 3/16"X 25 MM	1	
14	4-1040	WASHER M10 X 40	1	
15	7-8007	BOLT M8 X 35	2	
16	4-8006	WASHER, FLAT	X	
17	105-07000	STEERING HANDLE CLAMP	1	
18	53-0192	IGUS BEARING EFOM 25	1	
19	3-4027	GROMMET 43 X 40 X 31 X 8	2	
20	8-8008	NUT, M8	11	

STEERING COLUMN ASSY.

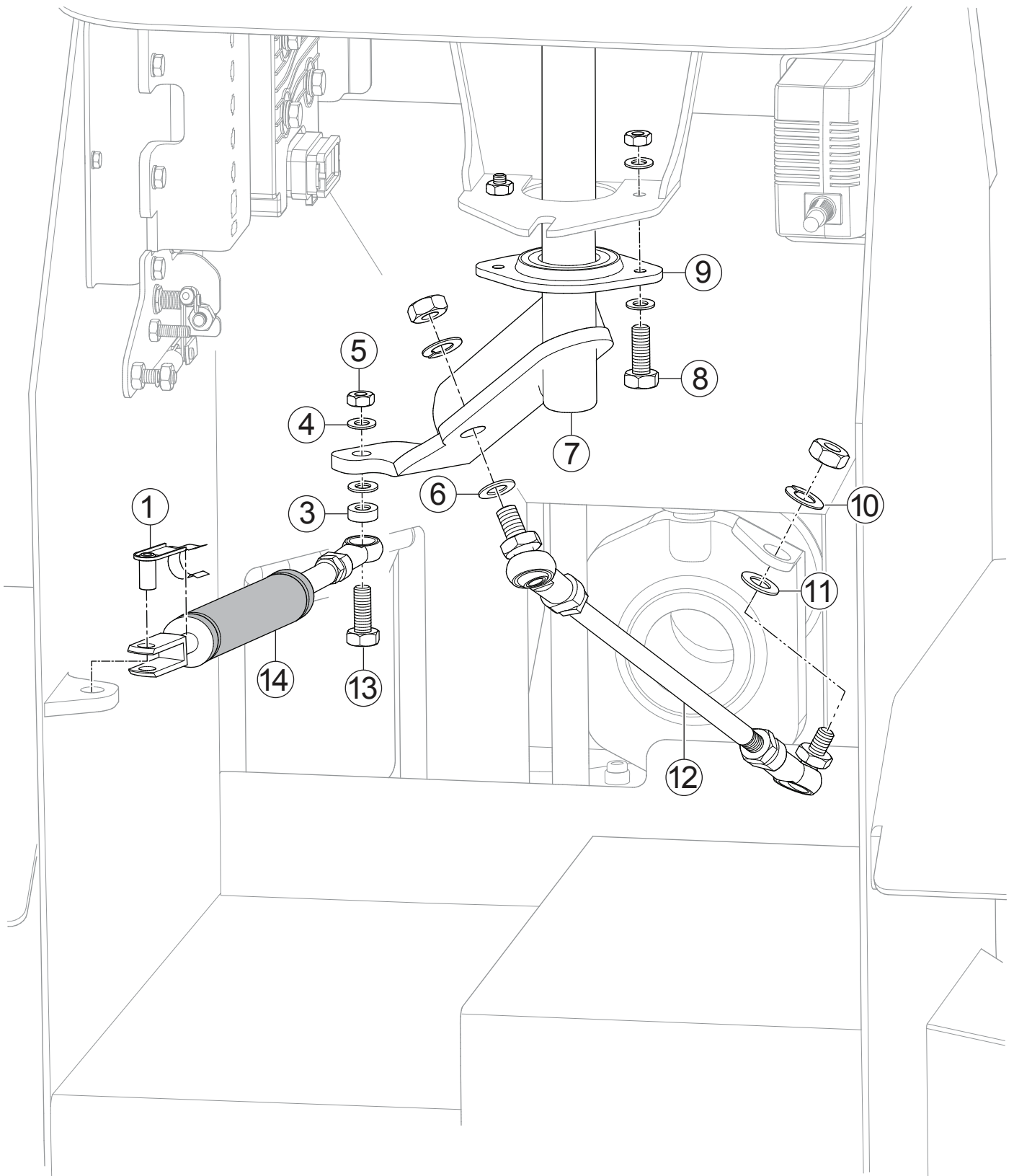

STEERING COLUMN ASSY.

<u>NO.</u>	<u>PART NO.</u>	<u>PART NAME</u>	<u>QTY.</u>	<u>REMARKS</u>
1	9-30016	CLEVIS PIN	1	
3	4-8020	SPACER M8 X 4	1	
4	4-8006	WASHER, FLAT M8	2	
5	8-8002	NUT M8	2	
6	4-9009	SHIM WASHER DIA.18 X 12	2	
7	105-08100	STEERING COLUMN	1	
8	7-8012	BOLT, M8 X 25	4	
9	53-0110	BEARING BALL, 25 BORE MOUNTED	1	
10	4-1202	WASHER, LOCK M12	2	
11	4-9009	SHIM WASHER DIA.18 X 12	2	
12	105-09800	STEERING ROD ASSY. M12	1	
13	7-8009	BOLT, M8 X 30	1	
14	2-1400	STEERING DAMPER	1	

CENTER STEERING ASSY.

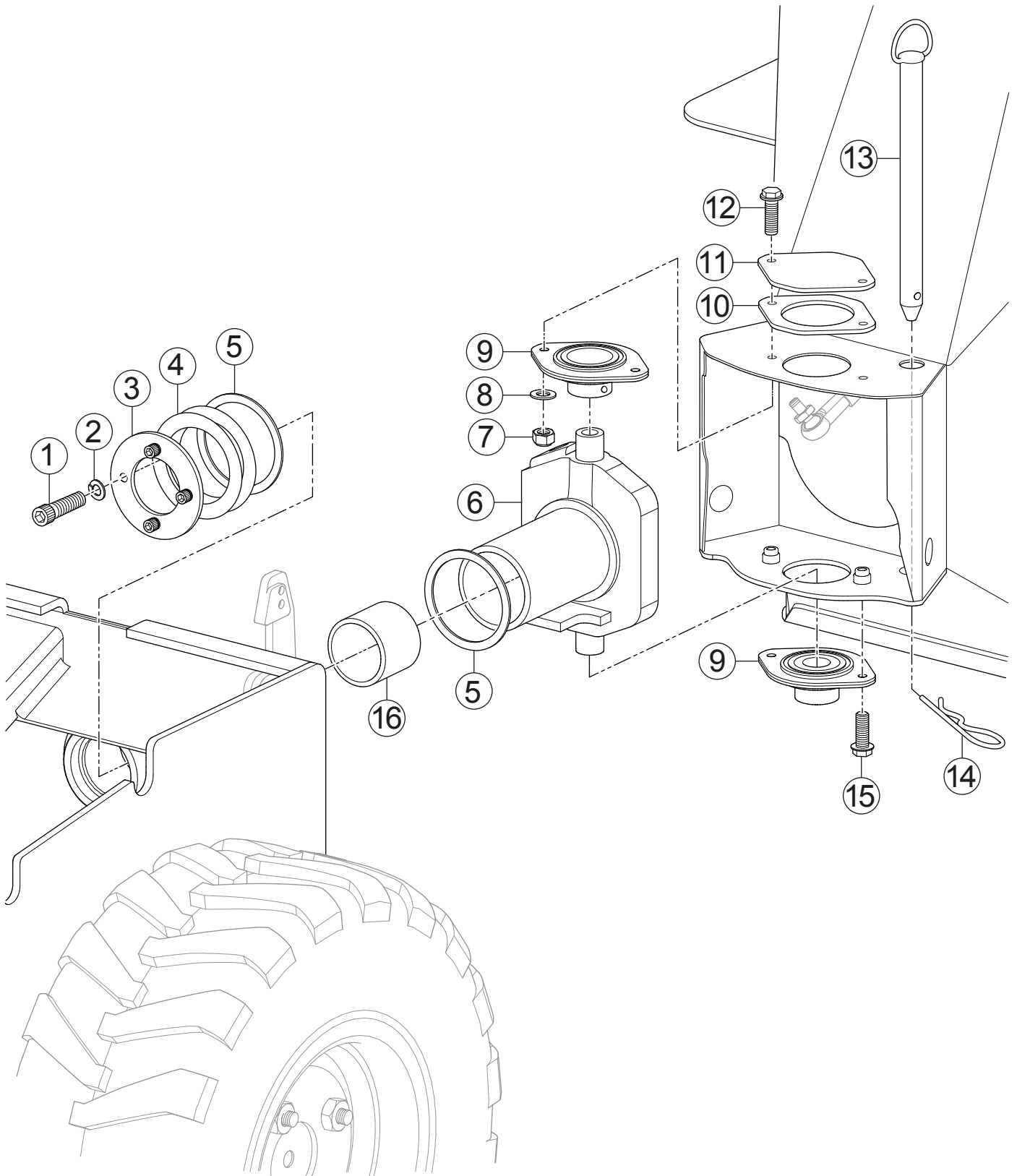

CENTER STEERING ASSY.

<u>NO.</u>	<u>PART NO.</u>	<u>PART NAME</u>	<u>QTY.</u>	<u>REMARKS</u>
1	7-6066	HEX HD. CAP SCREW M6 X 15	4	
2	4-6005	WASHER M6 SPRING	4	
3	105-99951	GIMBAL LOCK DISC	1	
4	4-9002	WAVE WASHER DIA. 71.53 X 55.88 X .76	2	
5	4-9003	SUPPORT WASHER, DIA.72 X 56 X 1MM	2	
6	105-05300	GIMBLE	1	
7	8-8002	NUT, M8	2	
8	4-8006	WASHER, FLAT M8	2	
9	53-0180	BEARING 20.00 BORE MOUNTED	2	
10	101-99943	SPACER BEARING COVER	1	
11	101-99942	PLATE BEARING COVER	1	
12	7-8012	BOLT, M8 X 25	2	
13	105-08700	ARTICULATION LOCKOUT, PIN	1	
14	3-2004	COTTER PIN	1	
15	7-8080	BOLT, SERRATED M8 X 20	2	
16	53-0193	COMPRESSION BUSHING.....	2.....	IGUS GSM-5560-40

FRONT CHASSIS ASSY.

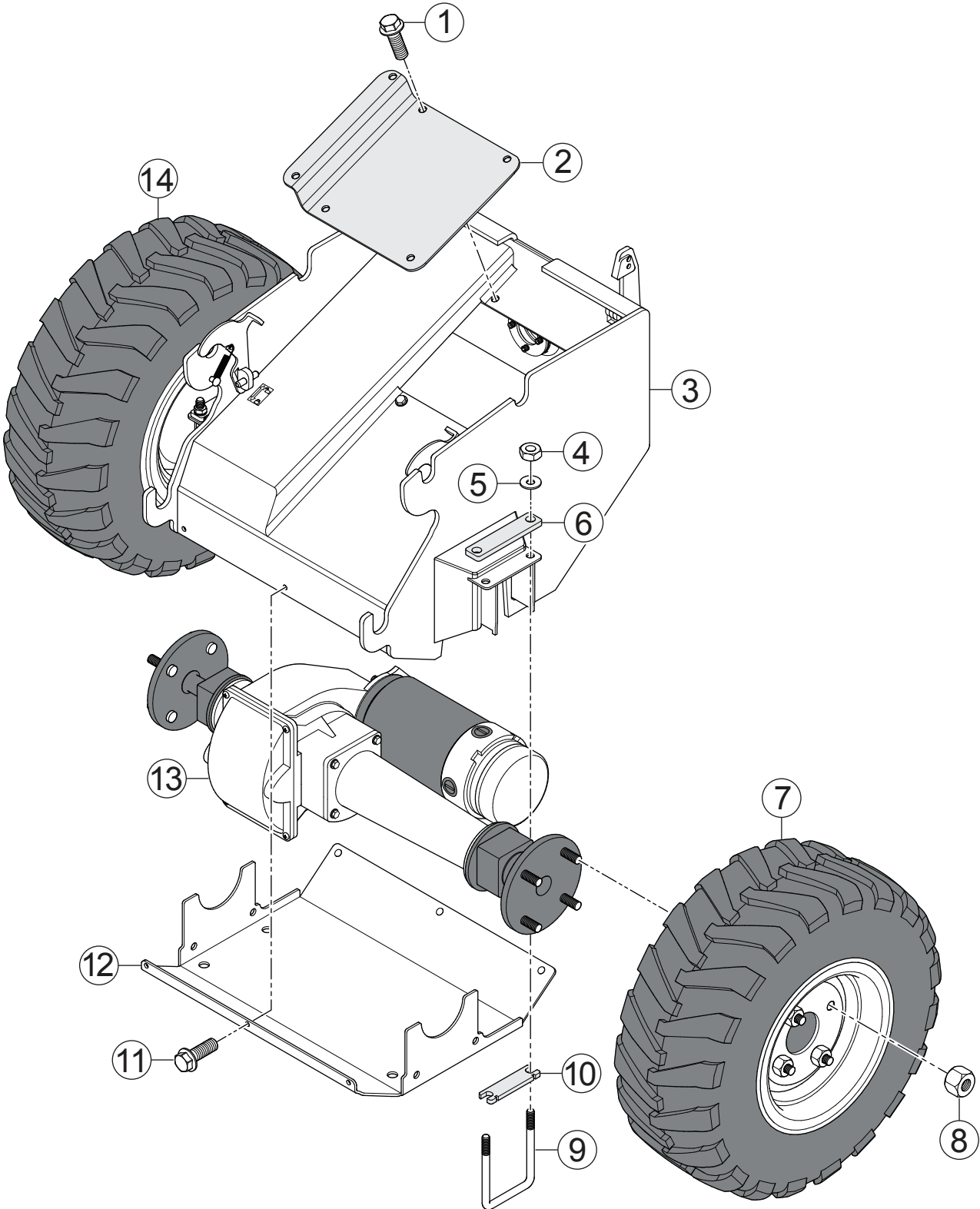

FRONT CHASSIS ASSY.

<u>NO.</u>	<u>PART NO.</u>	<u>PART NAME</u>	<u>QTY.</u>	<u>REMARKS</u>
1	7-6064	SCREW, SERRATED M6 X 12	4	
2	105-99958	ACCESS PLATE	1	
3	105-09500	CHASSIS, FRONT W/RIVNUTS	1	
4	8-10001	NUT M10	4	
5	4-1005	WASHER, FLAT M10	4	
6	105-99962	AXLE CLAMP UPPER	2	
7	60-6609LHF	WHEEL ASSY., LH FLOAT 16 X 6.5 X 8	1	
8	8-7161	WHEEL NUT 7/16" UNF	8	
9	7-10136	BOLT M10 X100	4	
10	105-99963	AXLE CLAMP, LOWER	2	
11	7-6064	SCREW SERRATED HD M6 X 12	10	
12	105-99931	ACCESS PANEL, FRONT	1	
13	70-7000	TRANSAXLE, 9H90-2100	1	
14	60-6609RHF	WHEEL ASSY., RH FLOAT 16 X 6.5 X 8	1	

REAR CHASSIS ASSY.

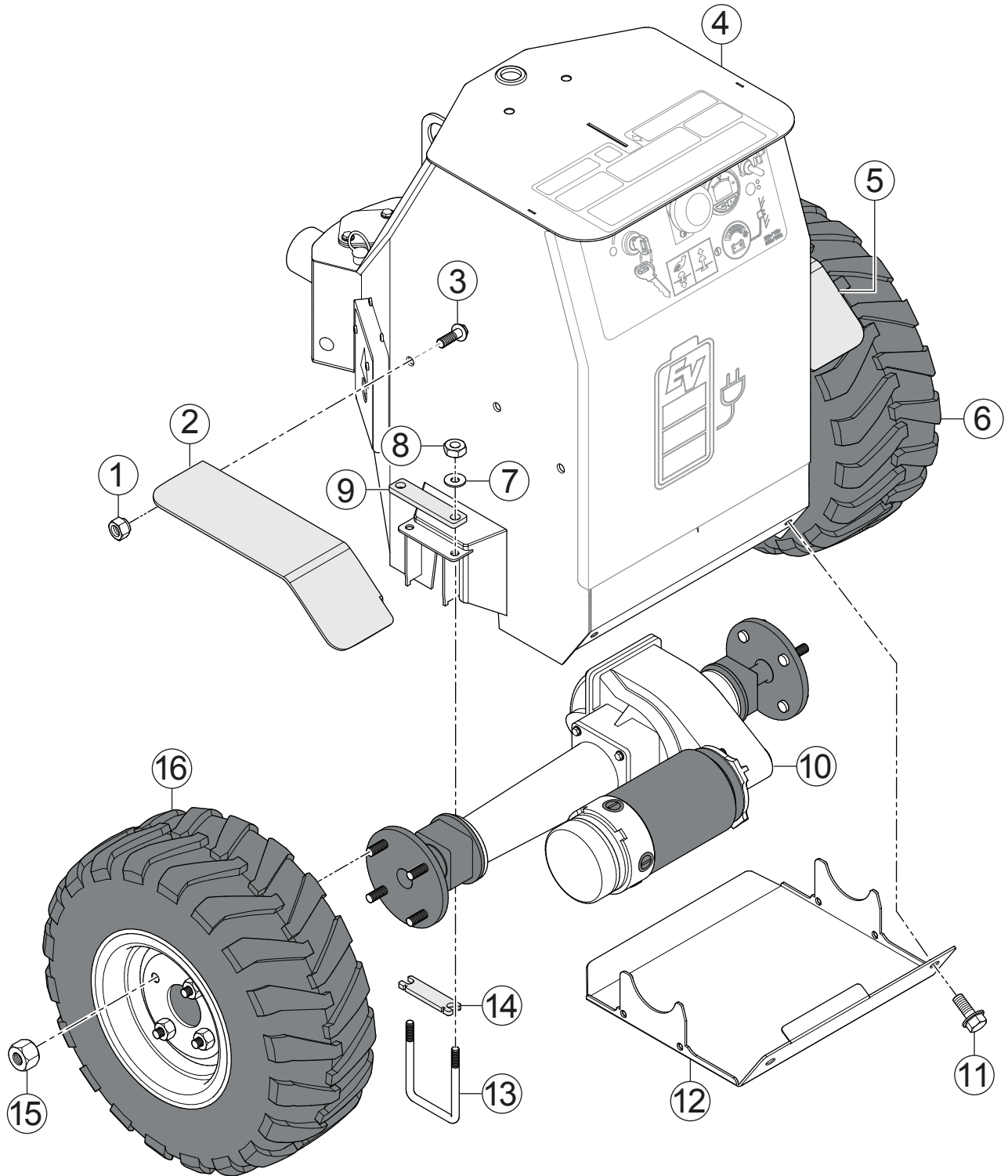

REAR CHASSIS ASSY.

<u>NO.</u>	<u>PART NO.</u>	<u>PART NAME</u>	<u>QTY.</u>	<u>REMARKS</u>
1	8-6031	NUT, M6 SERRATED FLANGE	6	
2	105-99941	LEFT-HAND MUD GUARD	1	
3	7-6062	CARRIAGE BOLT M6 X 16	6	
4	105-09600M	TOP REAR PANEL W/RIVET NUTS	1	
5	105-99942	RIGHT-HAND MUD GUARD	1	
6	60-6609RHF	WHEEL ASSY., RH FLOAT 16 X 6.5 X 8	1	
7	4-1005	WASHER, FLAT M10	4	
8	8-10001	NUT, M10	4	
9	105-99962	AXLE CLAMP, UPPER	2	
10	70-7000	TRANSAXLE 9H90-2100	1	
11	7-6064	SCREW M6 X 12 SER HD	9	
12	105-99952	ACCESS PANEL, REAR	1	
13	7-10136-0	BOLT M10 X 100 HT	4	
14	105-99963	AXLE CLAMP, LOWER	2	
15	8-7161	7/16" UNF WHEEL NUT	8	
16	60-6609LHF	WHEEL ASSY., LH FLOAT 16 X 6.5 X 8	1	

BACK PANEL ASSY.

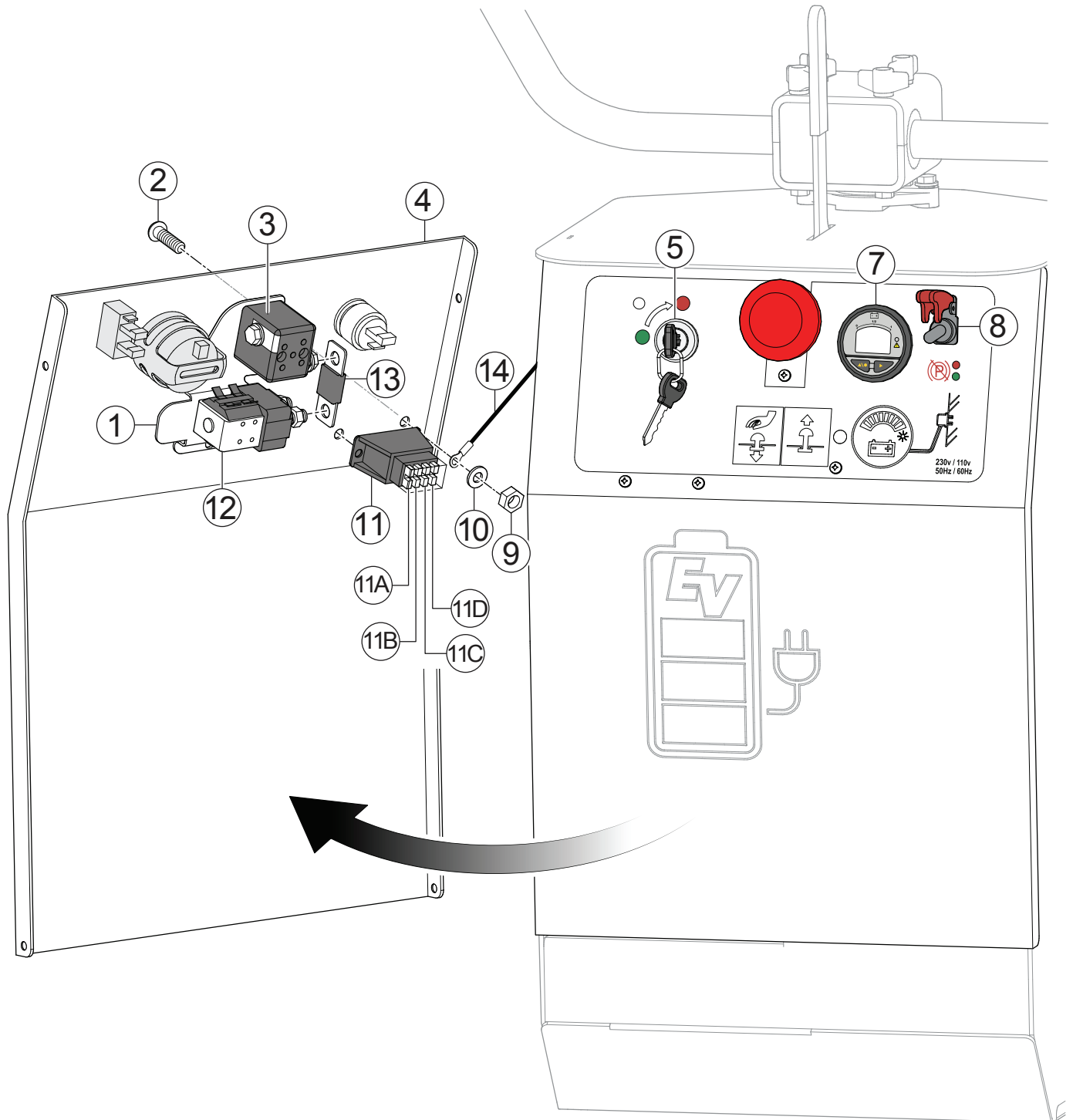

BACK PANEL ASSY.

<u>NO.</u>	<u>PART NO.</u>	<u>PART NAME</u>	<u>QTY.</u>	<u>REMARKS</u>
1	105-99973	E-STOP CONTACTOR MOUNT	1	
2	7-5002	BOLT M5 X 12 HEX	2	
3	70-0127	EMERGENCY STOP SW., CURTIS ED125	1	
4	105-99954	REAR PANEL	1	
5	70-8003	IGNITION SWITCH-CURTIS	1	
7	70-0133	ELECTRICAL DISPLAY	1	
8	70-0175SP	BRAKE OVER-RIDE SWITCH	1	
9	8-5003	NUT NYLOC M5	3	
10	4-5002	WASHER, M5	3	
11	70-0187	FUSE HOLDER	1	
11A	70-0189	FUSE, 20 AMP PTO, YELLOW	1	
11B	70-0188	FUSE, 10 AMP AUX 1, RED	1	
11C	70-0188	FUSE, 10 AMP AUX 2, RED	1	
11D	70-0188	FUSE, 10 AMP IGNITION, RED	1	
12	70-0128	SOLENOID 24V, CURTIS SW80-65	1	
13	70-0183	FUSE IN-LINE 100A MEGA	1	
14	9-30014	REAR COVER RETAINER	1	

TUB MOUNT AND LATCH ASSY.

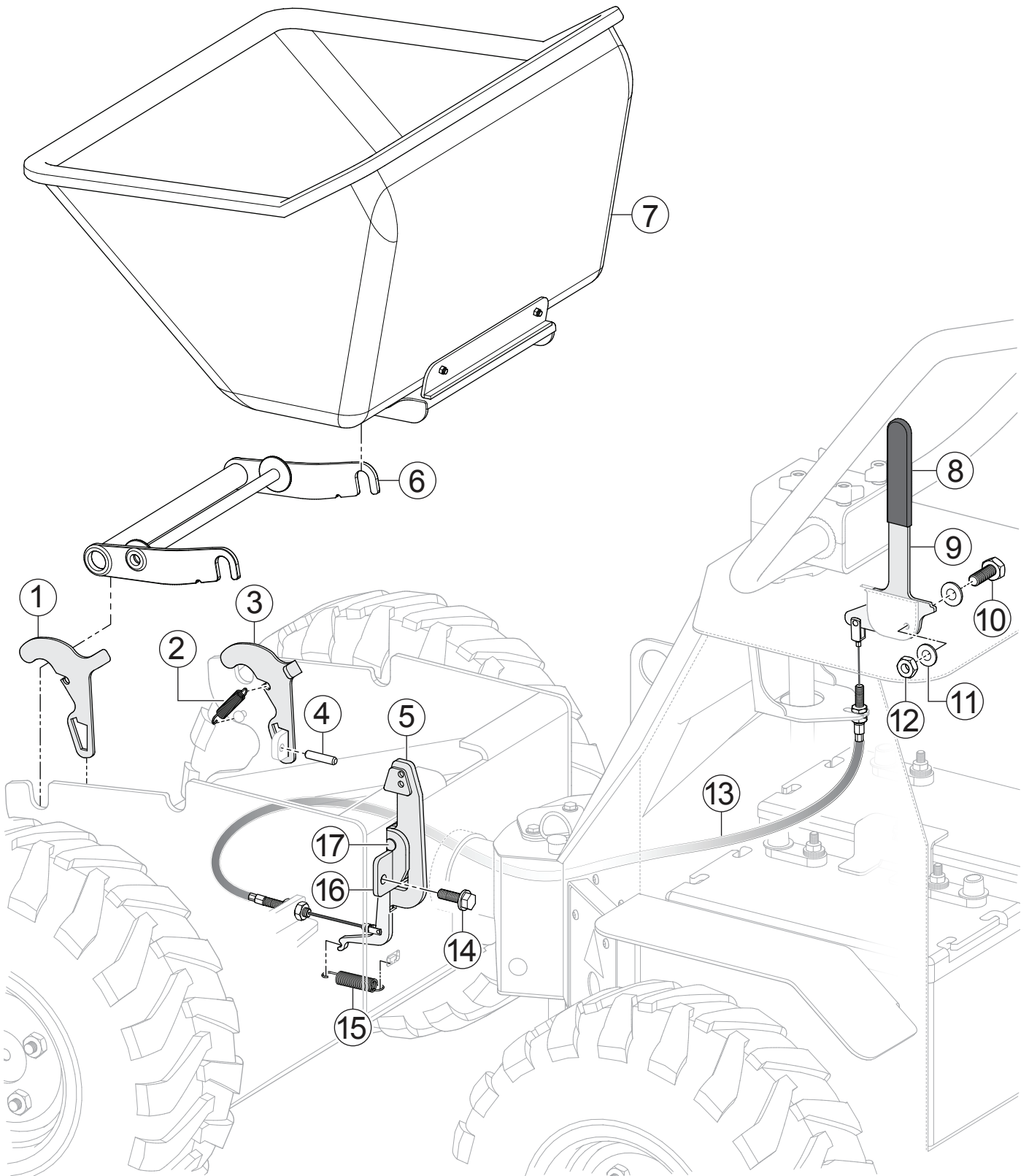

TUB MOUNT AND LATCH ASSY.

<u>NO.</u>	<u>PART NO.</u>	<u>PART NAME</u>	<u>QTY.</u>	<u>REMARKS</u>
1	105-99965	LEFT HAND TUB RETAINER	1	
2	2-1020	SPRING, TUB RETAINING	2	
3	105-99956	RIGHT HAND TUB RETAINER	1	
4	3-0102	PIN, C-SPRING DIA.6 X 30	2	
5	105-10500	E-TIP LATCH	1	
6	101-02100	FRAME, TUB CARRIER	1	
7	100-05700NSPFT	POLY TUB ASSY., FLEXTOOL LOGO	1	
8	72-0200	RUBBER TIP, HANDLE	1	
9	105-99946	TUB RELEASE HANDLE	1	
10	7-10005	SCREW SET M10 X 25	1	
11	4-10051	WASHER, FLAT M10	2	
12	8-10001	NUT, M10	1	
13	75-02800	CABLE, TUB RELEASE	1	
14	7-8080	HEX BOLT M8 X 20	2	
15	2-1010	SPRING, EXTENSION	1	
16	105-04500	BRACKET, TUB RELEASE	1	
17	3-0091	PIN, LATCH PIVOT	1	

BATTERY ASSY.

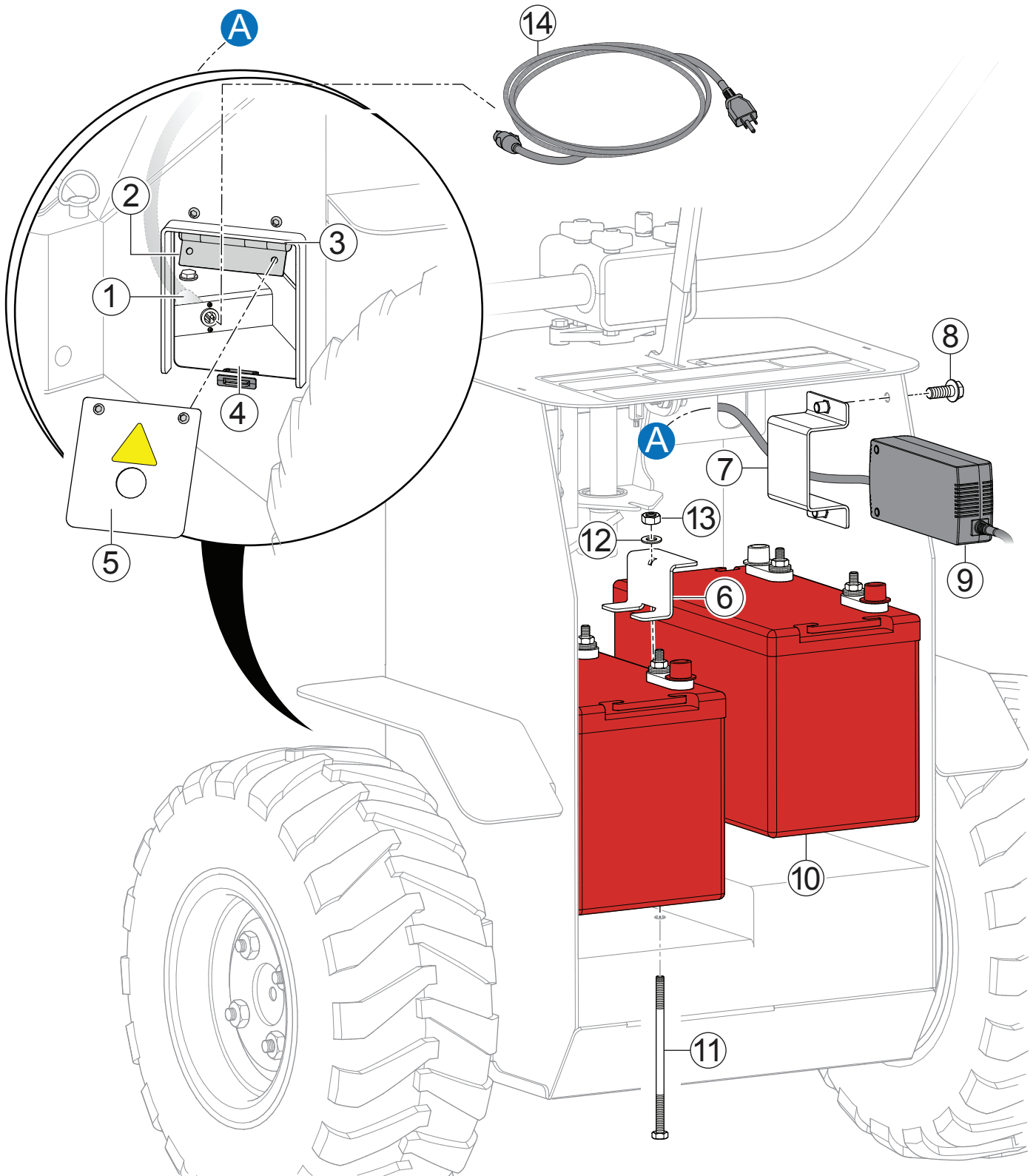

BATTERY ASSY.

<u>NO.</u>	<u>PART NO.</u>	<u>PART NAME</u>	<u>QTY.</u>	<u>REMARKS</u>
1	70-0167	STD CHARGE SOCKET ASSY.	1	
2	7-5037	HEX HED TAPTITE, M5 X 10	1	
3	74-1051	HINGE, 100 MM	1	
4	74-1053	MAGNET LATCH	1	
5	105-99945	ACCESS FLAP	1	
6	105-99968	BATTERY RETAINER	1	
7	105-09400SP	BATTERY CHARGER BRACKET ASSY.	1	
8	7-6064	SCREW M6 X 12 SERRATED	2	
9	70-0134	BATTERY CHARGER	1	
10	70-3400	BATTERY 12V 105Ah AGM	2	
11	105-99969	RETAINING ROD, BATTERY BRACKET	1	
12	4-8006	WASHER, FLAT, M8	2	
13	8-8008	NYLOC, NUT	1	
14	70-6519	AC POWER CORD, EXTERNAL	1	

JUNCTION BOX/CONTROLLER ASSY.

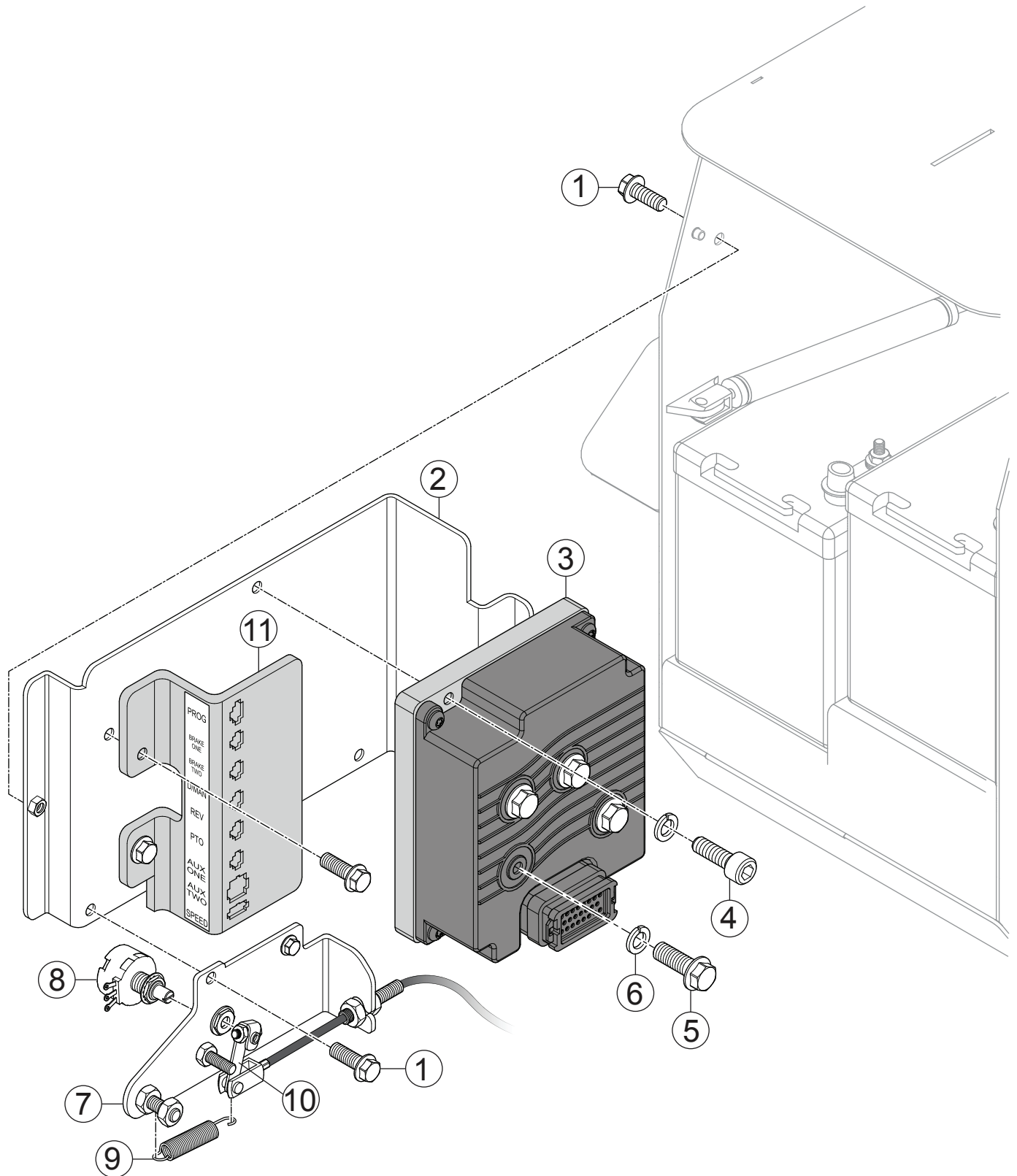

JUNCTION BOX/CONTROLLER ASSY.

<u>NO.</u>	<u>PART NO.</u>	<u>PART NAME</u>	<u>QTY.</u>	<u>REMARKS</u>
1	7-6064	SCREW SERRATED HD M6 X 12	1	
2	105-09300	CONTROLLER BRACKET	1	
3	70-0129	DC MOTOR CONTROLLER, CURTIS	1	
4	7-6063	CAP HD SCREW, M6 X 25	2	
5	7-6001	SCREW SET, M6 X 12	4	
6	4-6005	WASHER, LOCK M6	6	
7	105-99966	BRACKET.	1	
8	70-0140	5K OHM POTENTIOMETER	1	S/N EB221128 ~ EB221592
8	70-01405SP	5K OHM POTENTIOMETER W/LEADS	1	S/N EB221593 AND ABOVE
9	2-1014	SPRING, SPEED CONTROL	1	
10	101-99975	CLAMP LEVER, POTENTIOMETER	1	
11	105-99967	JUNCTION BOX	1	

POWER/GND CABLE ASSY.

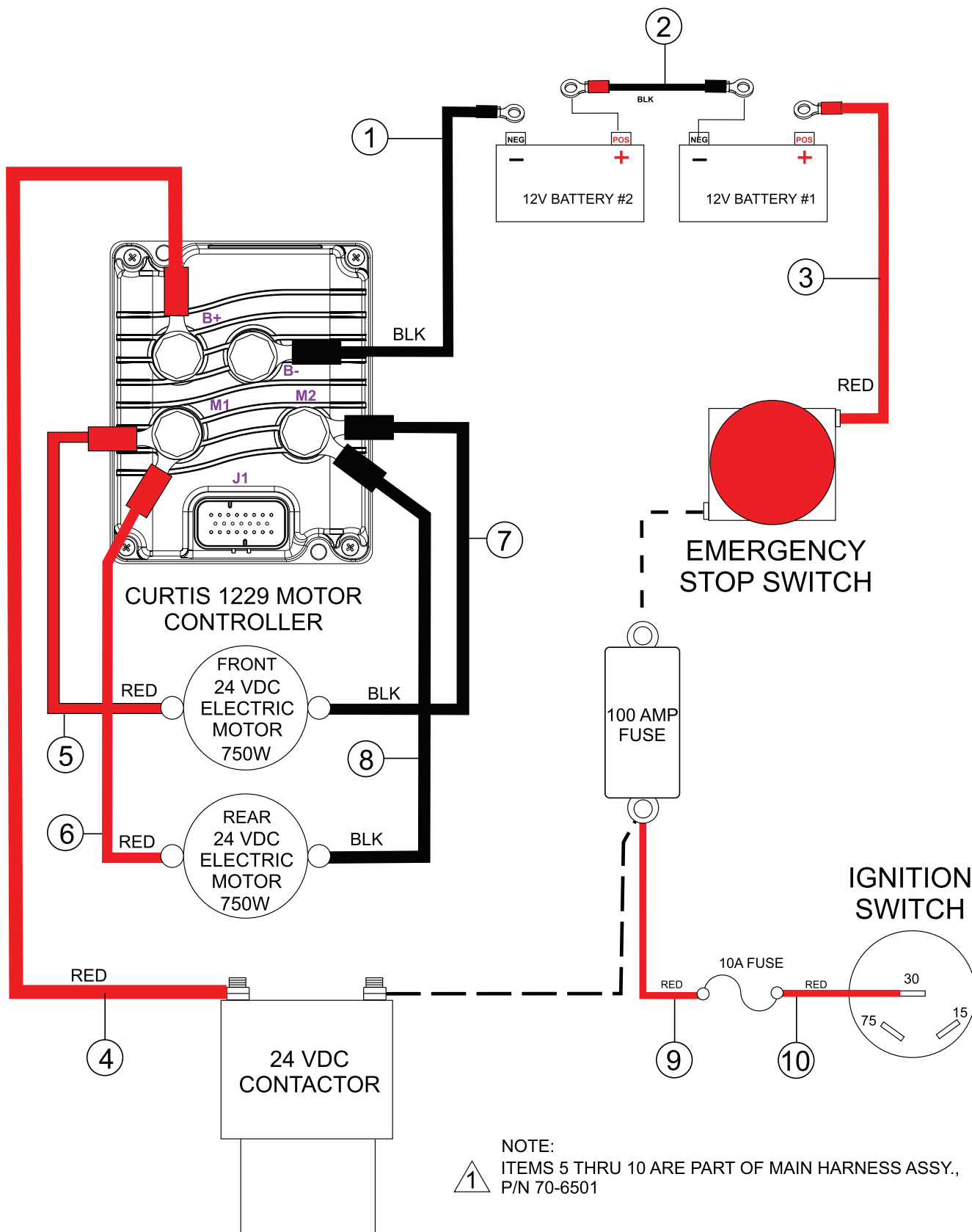

POWER/GND CABLE ASSY.

<u>NO.</u>	<u>PART NO.</u>	<u>PART NAME</u>	<u>QTY.</u>	<u>REMARKS</u>
1	70-6502	GND. CABLE 1.96 FT. (600 MM), BLK	1	
2	70-6509	JUMPER CABLE 1.31 FT. (400 MM), BLK	1	
3	70-6505	PWR. CABLE 2.13 FT. (650 MM), RED	1	
4	70-6503	PWR. CABLE 2.13 IN. (650 MM), RED	1	
5		PWR. CABLE, FRONT TRANSAXLE.....	1	ORDER P/N 70-6501 MAIN PWR HARNESS
6		PWR. CABLE, REAR TRANSAXLE	1	ORDER P/N 70-6501 MAIN PWR HARNESS
7		GND. CABLE, FRONT TRANSAXLE	1	ORDER P/N 70-6501 MAIN PWR HARNESS
8		GND. CABLE, REAR TRANSAXLE.....	1	ORDER P/N 70-6501 MAIN PWR HARNESS
9		EMERGENCY STOP TO 10A FUSE.....	1	ORDER P/N 70-6501 MAIN PWR HARNESS
10		10A FUSE, IGNITION	1	ORDER P/N 70-6501 MAIN PWR HARNESS

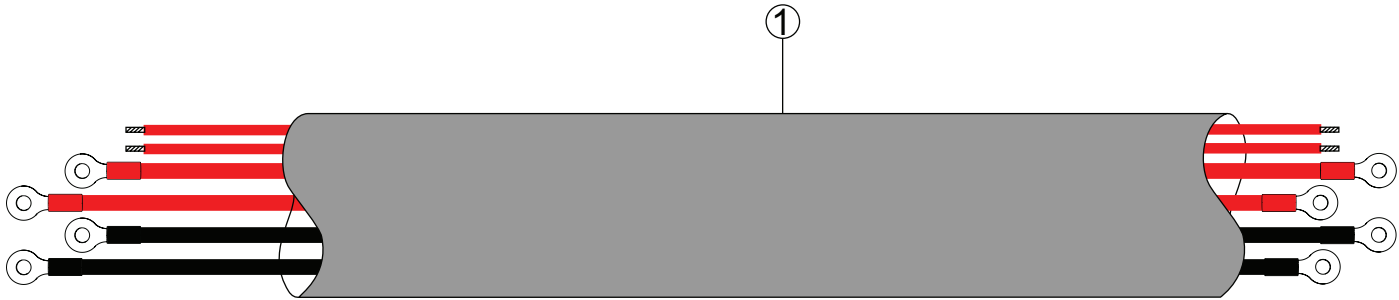

HARNES ASSY.

<u>NO.</u>	<u>PART NO.</u>	<u>PART NAME</u>	<u>QTY.</u>	<u>REMARKS</u>
1	70-6501	MAIN PWR HARNESS	1	

TUB TIPPING HANDLE ASSY. (OPTION)

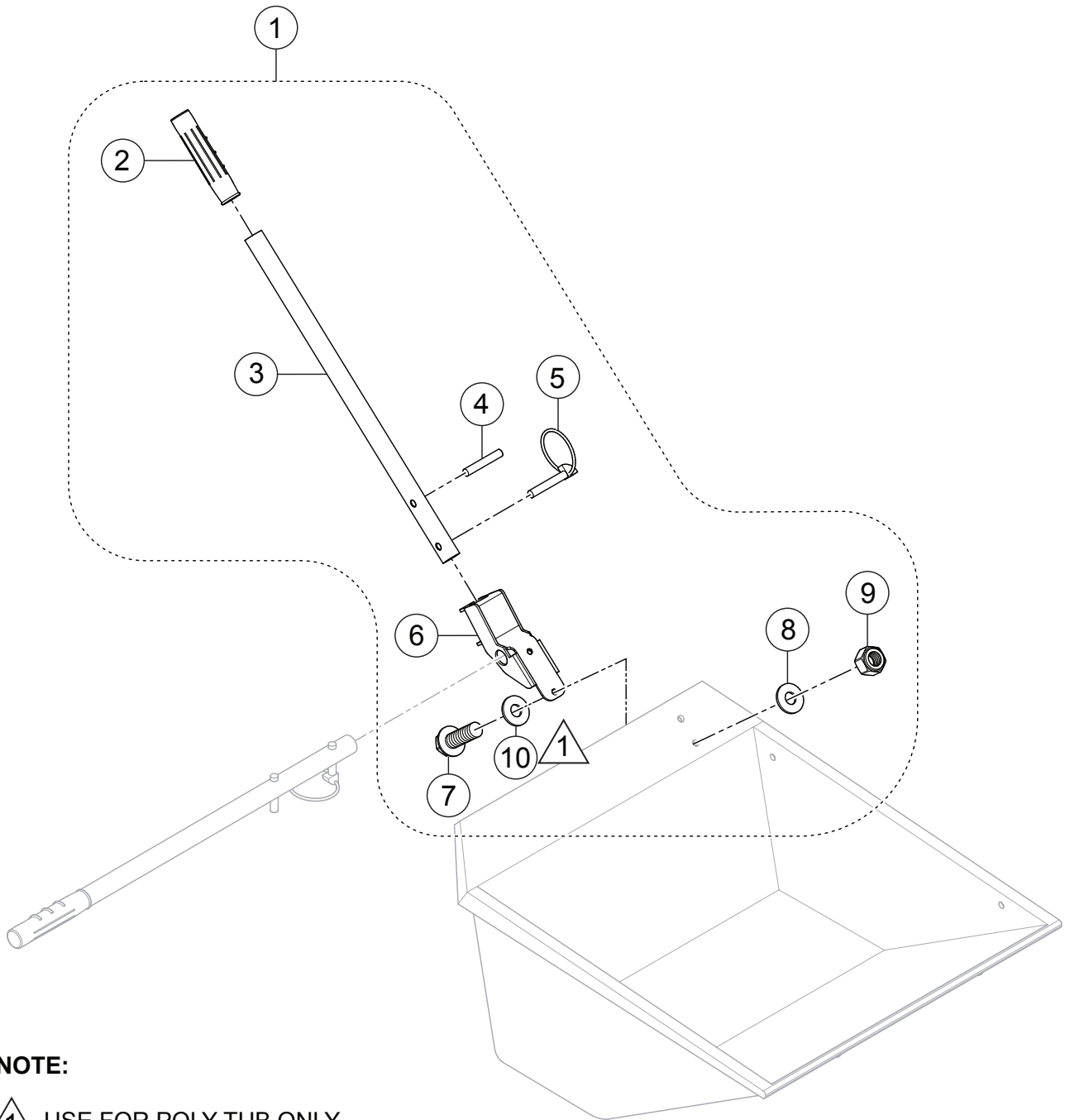

NOTE:

1 USE FOR POLY TUB ONLY

TUB TIPPING HANDLE ASSY. (OPTION)

<u>NO.</u>	<u>PART NO.</u>	<u>PART NAME</u>	<u>QTY.</u>	<u>REMARKS</u>
1	OPTT16-DIO	TUB TIPPING HANDLE, STEEL TUB	1	
1	OPTT25-DIO	TUB TIPPING HANDLE, POLY TUB	1	
2	74-1022	GRIP, HANDLE	1	
3	73-1703	HANDLE	1	
4	3-0096	ROLL PIN	1	
5	3-1018	LYNCH PIN	1	
6	73-1700	HANDLE SUPPORT BRACKET	1	
7	7-6060	SCREW, SERRATED HD M6 X 14 STEEL TUB	2	
7	7-6025	SCREW, HEX HD M6 X 25 POLY TUB	2	
8	4-6001	WASHER M6	2	
8	4-6018	WASHER M6, 20 X 1.2	2	
9	8-6007	NYLOC NUT, M6	2	
10	4-6001	WASHER M6, POLY TUB	2	

TUB EXTENSION ASSY. (OPTION)

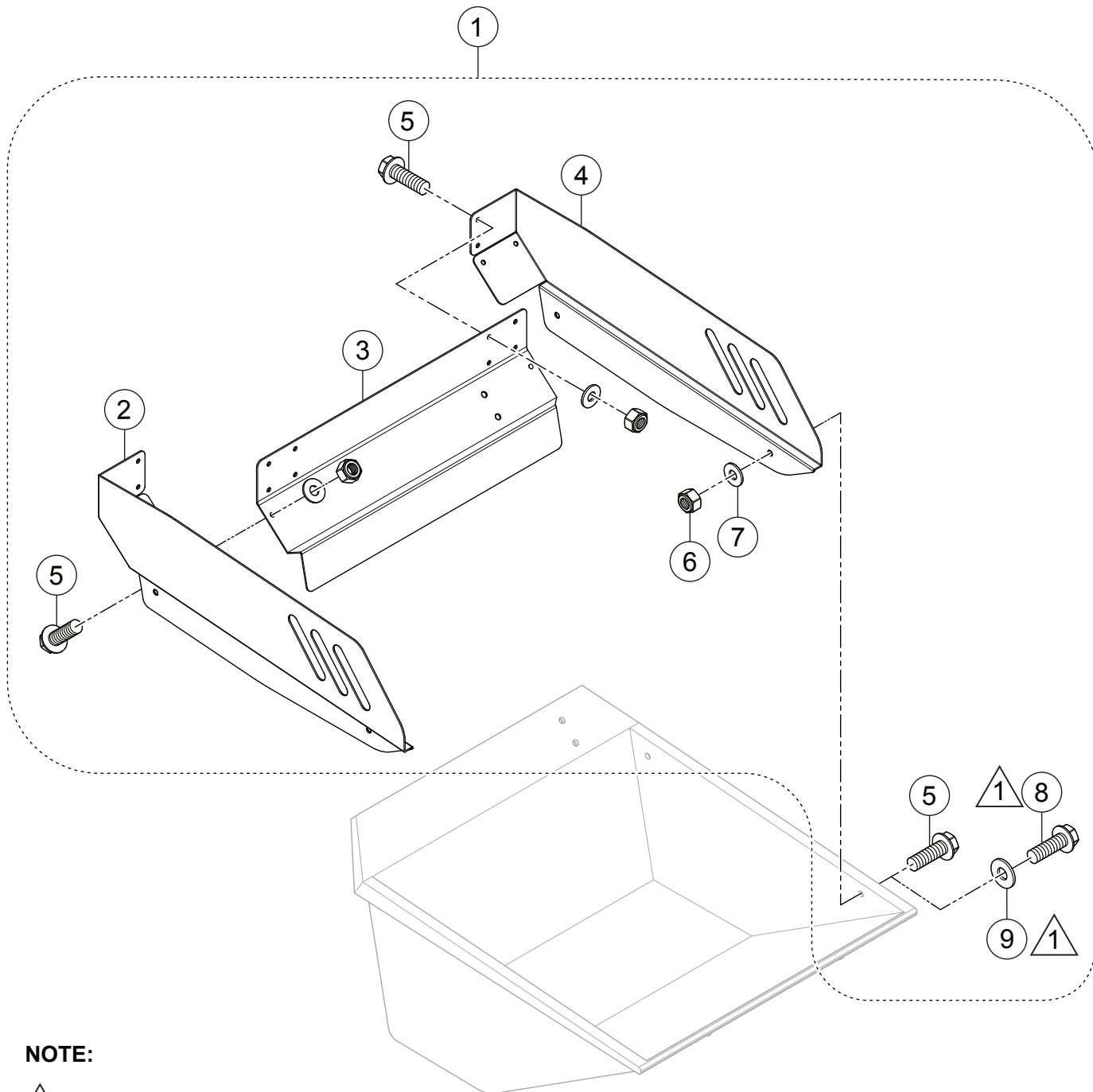

NOTE:

 USE FOR POLY TUB ONLY

TUB EXTENSION ASSY. (OPTION)

<u>NO.</u>	<u>PART NO.</u>	<u>PART NAME</u>	<u>QTY.</u>	<u>REMARKS</u>
1	OPTT34-DIOGG	TUB EXTENSION ASSY., STEEL TUB	1	
1	OPTT36-DIOGG	TUB EXTENSION ASSY., POLY TUB	1	
2	73-3702GG	EXTENSION PANEL, RIGHT-SIDE, STEEL TUB	1	
2	73-3705GG	EXTENSION PANEL, RIGHT-SIDE, POLY TUB	1	
3	73-3703GG	EXTENSION PANEL, REAR, STEEL TUB	1	
3	73-3603GG	EXTENSION PANEL, REAR, POLY TUB	1	
4	73-3701GG	EXTENSION PANEL, LEFT-SIDE, STEEL TUB	1	
4	73-3604GG	EXTENSION PANEL, LEFT-SIDE, POLY TUB	1	
5	7-6060	BOLT, SERRATED M6 X 14, STEEL TUB	10	
5	7-6060	BOLT, SERRATED M6 X 14, POLY TUB	4	
6	8-6007	NUT	10	
7	4-6001	WASHER, FLAT	10	
8	7-6025	SCREW, M6 X 25, POLY TUB	4	
9	4-6018	WASHER, M6 20 X 1.2, POLY TUB	6	

TOW HITCH ASSY. (OPTION)

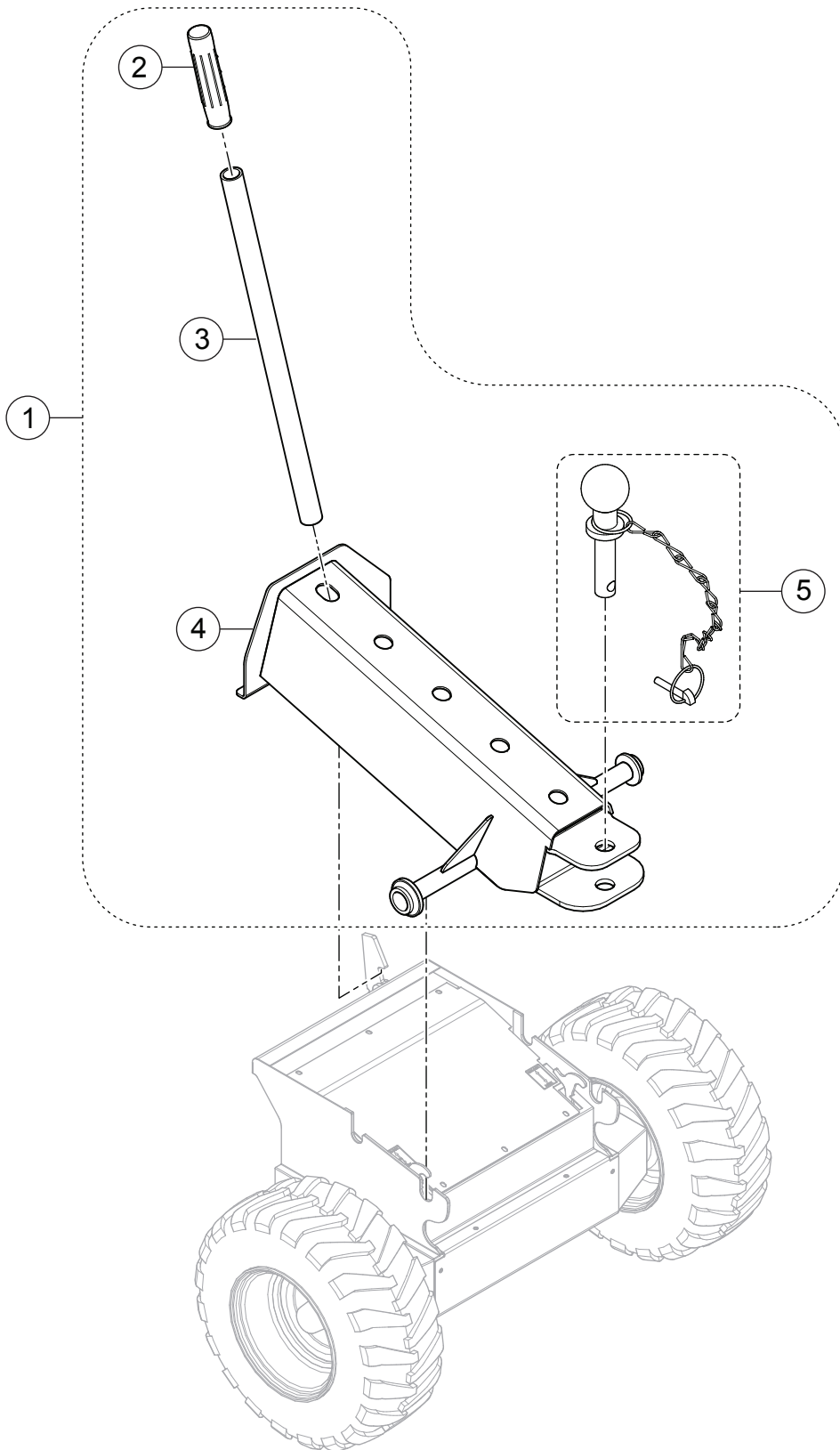

TOW HITCH ASSY. (OPTION)

<u>NO.</u>	<u>PART NO.</u>	<u>PART NAME</u>	<u>QTY.</u>	<u>REMARKS</u>
1	OPTT11-DIO	HITCH ASSY.....	1.....	INCLUDES ITEMS W/#
2#	74-1022	GRIP, HANDLE	1	
3#	73-1500	HANDLE, HITCH	1	
4#	73-1300	HITCH, TOWBALL BODY W/A	1	
5#	73-1400	2-INCH TOW BALL W/CHAIN AND PIN	1	

FLATBED ASSY. (OPTION)

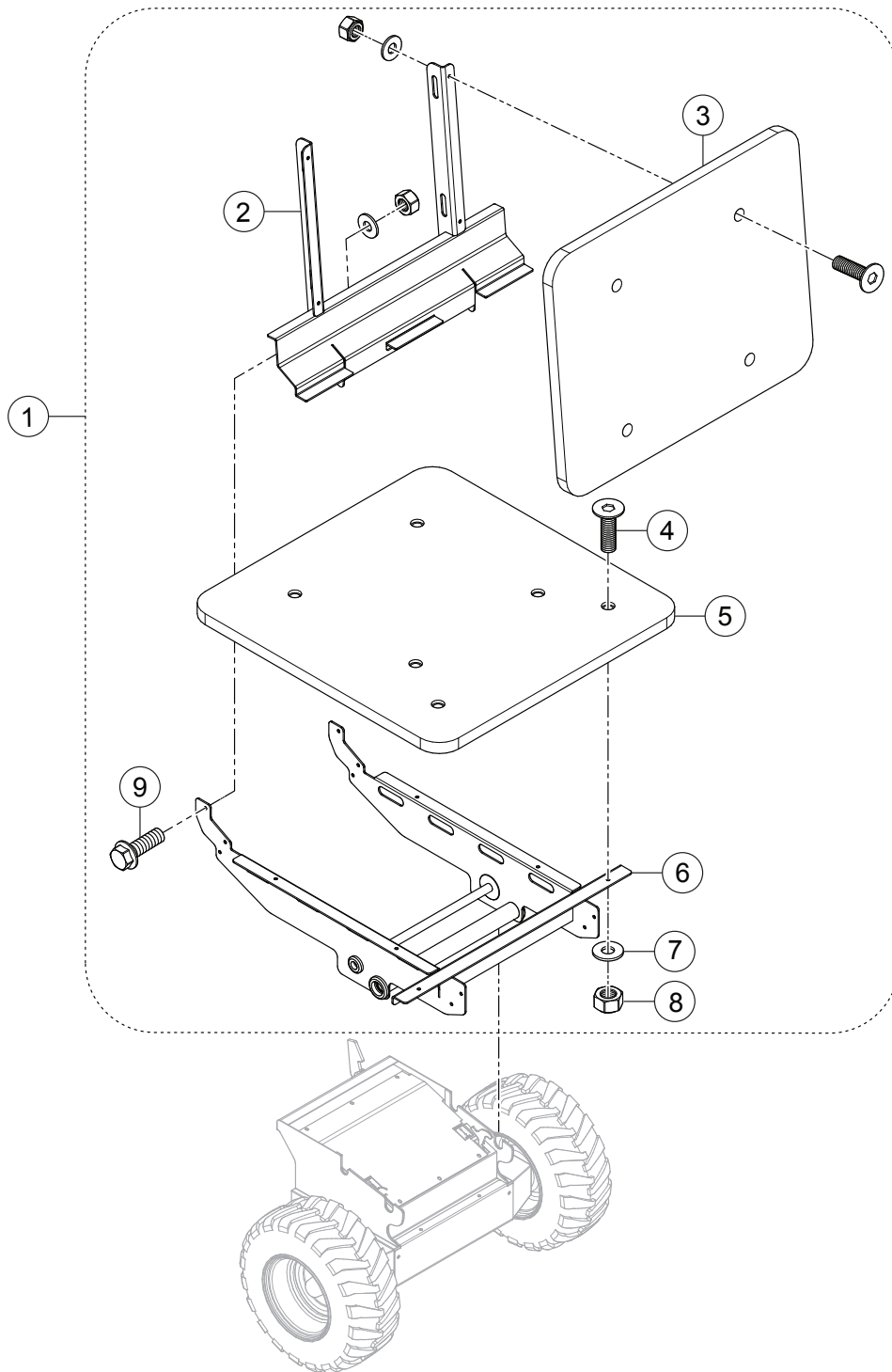

FLATBED ASSY. (OPTION)

<u>NO.</u>	<u>PART NO.</u>	<u>PART NAME</u>	<u>QTY.</u>	<u>REMARKS</u>
1	OPTT14-DIO	FLATBED ASSEMBLY	1.....	INCLUDES ITEMS W/#
2#	73-0900	FLATBED, FRAME TOP, REAR W/A	1	
3	73-0120	COMPOSITE BOARD, TOP REAR	1	
4#	7-10035	SCREW, COUNTERSUNK M10 X 35	10	
5#	73-0119	COMPOSITE BOARD, BOTTOM	1	
6#	73-0100	FLATBED, FRAME BOTTOM	1	
7#	4-1005	WASHER, FLAT M10	22	
8#	8-10006	NUT, M10 NYLOC	16	
9#	7-10005	SCREW, M10 X 25	6	

FLATBED LOAD STOP ASSY. (OPTION)

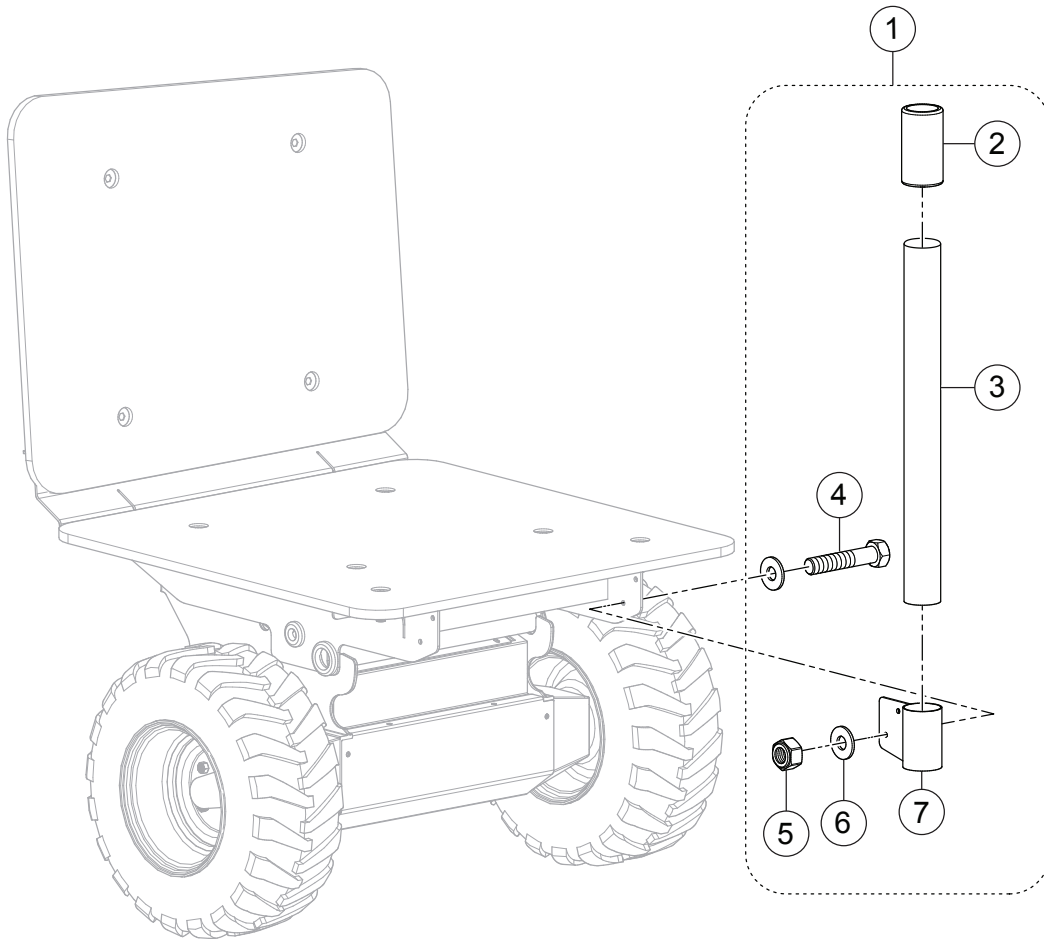

FLATBED LOAD STOP ASSY. (OPTION)

<u>NO.</u>	<u>PART NO.</u>	<u>PART NAME</u>	<u>QTY.</u>	<u>REMARKS</u>
1	OPTT13-DIO	FLATBED TUBE ASSY.....	1.....	INCLUDES ITEMS W/#
2#	72-0400	CAP, RUBBER	2	
3#	73-1200	TUBE	2	
4#	7-10005	SCREW, M10 X 25	4	
5#	8-10006	NUT, M10 NYLOC	4	
6#	4-1005	WASHER, FLAT M10	8	
7#	73-1100	HOLDER, TUBE	2	



Parchem Construction Supplies Pty Ltd

1956 Dandenong Road, Clayton VIC 3168, Australia

Phone: 1300 353 986

flextool.com.au

ABN 80 069 961 968

This manual summarises our best knowledge of the product based on the information available at the time of publication. You should read this manual carefully and consider the information in the context of how the product will be used. Our responsibility for products sold is subject to our standard terms and conditions of sale.

DISCLAIMER:

Any advice, recommendation, information, assistance or service provided by us in this manual is given in good faith and is believed by us to be appropriate and reliable. However, any advice, recommendation, information, assistance or service provided by us is provided without liability or responsibility PROVIDED THAT the foregoing shall not exclude, limit, restrict or modify the right entitlements and remedies conferred upon any person or the liabilities imposed upon us by any condition or warranty implied by Commonwealth, State or Territory Act or ordinance void or prohibiting such exclusion limitation or modification. The product can be expected to perform as indicated in this manual so long as operation and operational procedures of the individual products are followed as recommended in this manual.

Design and technical specifications may be subject to changes.

© This publication is copyright. All rights are reserved. Flextool is a registered trade mark and TuffTruk is a trade mark of Parchem Construction Supplies Pty Ltd.

FOR MORE INFORMATION

CONTACT US ON 1300 353 986 OR VISIT flextool.com.au