

WSM

WORKSHOP MANUAL **GASOLINE,LPG,ENGINE**

**WG752-G-E3, WG752-GL-E3,
WG972-G-E3, WG972-GL-E3**

Kubota

TO THE READER

This Workshop Manual tells the servicing personnel about the mechanism, servicing and maintenance of the WG752-G-E3, WG752-GL-E3, WG972-G-E3 and WG972-GL-E3. It contains 4 parts: "**Information**", "**General**", "**Mechanism**" and "**Servicing**".

■ **Information**

This section contains information below.

- Safety First
- Specification
- Performance Curve
- Important Items of Exhaust Emission Regulation
- Dimension
- Wiring Diagram

■ **General**

This section contains information below.

- Engine Identification
- General Precautions
- Maintenance Check List
- Check and Maintenance
- Special Tools

■ **Mechanism**

This section contains information on the structure and the function of the unit. Before you continue with the subsequent sections, make sure that you read this section.

Refer to the latest version of Workshop Manual (Code No. 9Y021-01870 / 9Y021-18200) for the diesel engine / tractor mechanism that this workshop manual does not include.

■ **Servicing**

This section contains information below.

- Troubleshooting
- Servicing Specifications
- Tightening Torques
- Checking, Disassembling and Servicing

All illustrations, photographs and specifications contained in this manual are of the newest information available at the time of publication.

KUBOTA reserves the right to change all information at any time without notice.

Since this manual includes many models, information or illustrations and photographs can show more than one model.

March, 2011

© KUBOTA Corporation 2011

I INFORMATION

INFORMATION

CONTENTS

1. SAFETY FIRST	I-1
2. SPECIFICATIONS	I-4
3. IMPORTANT ITEMS OF EXHAUST EMISSION REGULATION.....	I-6
[1] INLET AND EXHAUST SYSTEM	I-7
[2] ALTITUDE COMPENSATION KIT (WG752-G/GL-E3, WG972-G/GL-E3).....	I-7
[3] LPG REGULATOR WITH VAPORIZER (WG752-GL-E3, WG972-GL-E3).....	I-8
[4] KUBOTA RECOMMENDED LPG FUEL SPECIFICATIONS.....	I-8
[5] LENGTH OF THE LPG VAPOR HOSE (WG752-GL-E3, WG972-GL-E3).....	I-8
4. PERFORMANCE CURVES.....	I-9
5. DIMENSIONS	I-11
6. WIRING DIAGRAM.....	I-13

1. SAFETY FIRST

SAFETY FIRST

- This symbol, the industry's "Safety Alert Symbol", is used throughout this manual and on labels on the machine itself to warn of the possibility of personal injury. Read these instructions carefully.
- It is essential that you read the instructions and safety regulations before you attempt to repair or use this unit.

DANGER

- Indicates an imminently hazardous situation which, if not avoided, will result in death or serious injury.

WARNING

- Indicates a potentially hazardous situation which, if not avoided, could result in death or serious injury.

CAUTION

- Indicates a potentially hazardous situation which, if not avoided, may result in minor or moderate injury.

■ IMPORTANT

- Indicates that equipment or property damage could result if instructions are not followed.

■ NOTE

- Gives helpful information.

WSM000001INI0001US1

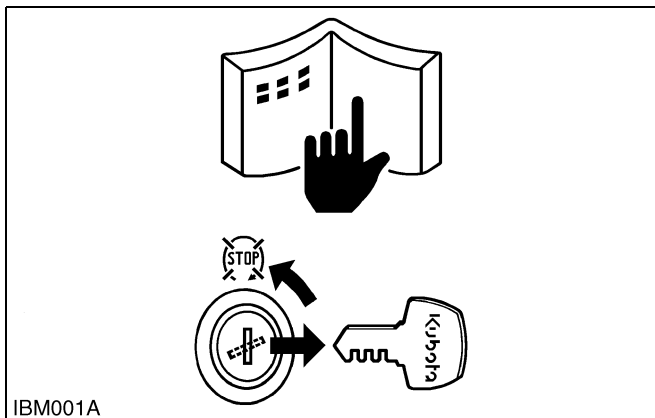

BEFORE YOU START SERVICE

- Read all instructions and safety instructions in this manual and on your engine safety decals.
- Clean the work area and engine.
- Park the machine on a stable and level ground.
- Let the temperature of the engine decrease before you start a job.
- Stop the engine, then remove the key.
- Disconnect the battery negative cable.
- Hang a "DO NOT OPERATE" tag in the operator station.

WSM000001INI0002US0

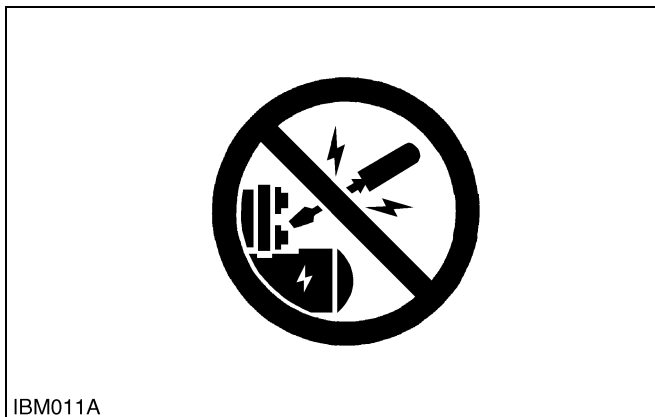

START SAFELY

- Do not do the procedures below when you start the engine.
 - short across starter terminals
 - bypass the safety start switch
- Do not make unauthorized modifications to the engine. This can cause damage and decrease the engine life.

WSM000001INI0003US0

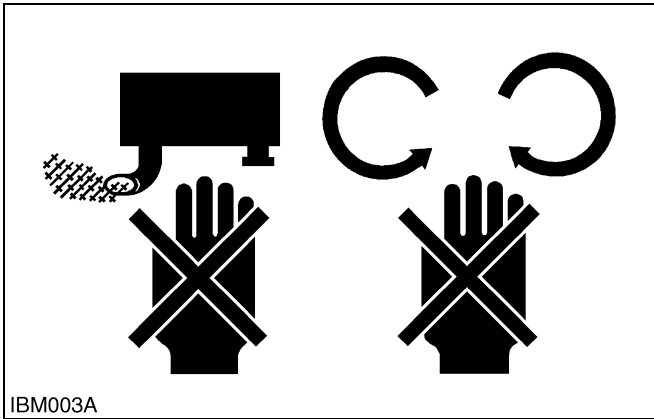

IBM003A

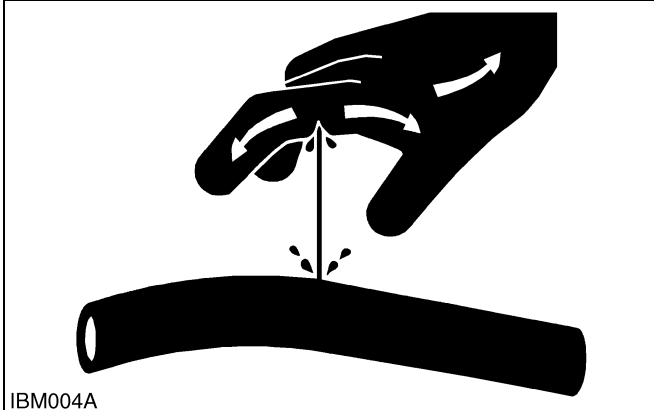

IBM004A

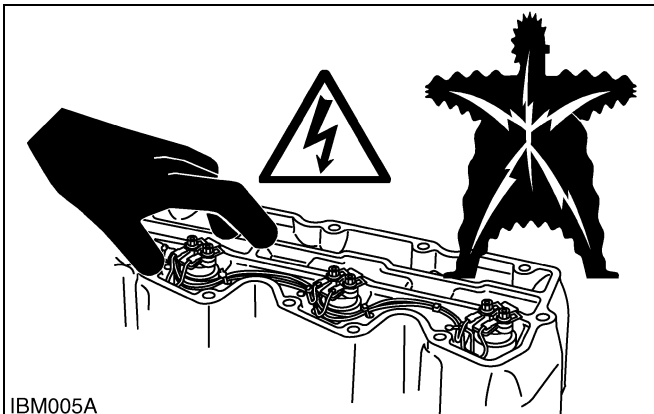

IBM005A

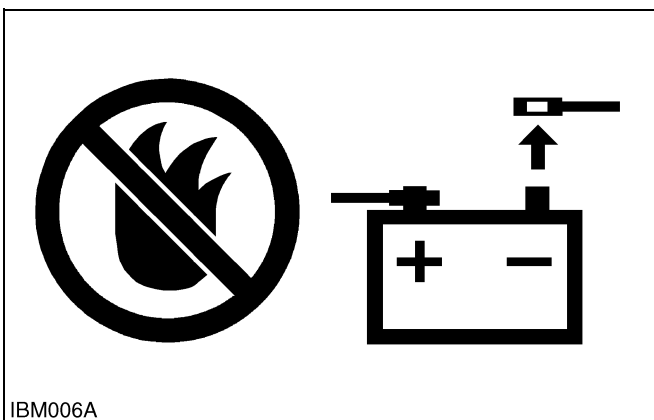

IBM006A

OPERATE SAFELY

- Do not use the machine after you consume alcohol or medication or when you are tired.
- Put on applicable clothing and safety equipment.
- Use applicable tools only. Do not use alternative tools or parts.
- When 2 or more persons do servicing, make sure that you do it safely.
- Do not touch the hot parts or parts that turn when the engine operates.
- Do not remove the radiator cap when the engine operates, or immediately after it stops. If not, hot water can spout out from the radiator. Only remove the radiator cap when it is at a sufficiently low temperature to touch with bare hands. Slowly loosen the cap to release the pressure before you remove it fully.
- Released fluid (fuel or hydraulic oil) under pressure can cause damage to the skin and cause serious injury. Release the pressure before you disconnect hydraulic or fuel lines. Tighten all connections before you apply the pressure.
- Do not open a fuel system under high pressure. The fluid under high pressure that stays in fuel lines can cause serious injury. Do not disconnect or repair the fuel lines, sensors, or any other components between the fuel pump and injectors on engines with a common rail fuel system under high pressure.
- Put on an applicable ear protective device (earmuffs or earplugs) to prevent injury against loud noises.
- Be careful about electric shock. The engine generates a high voltage of more than DC100 V in the ECU and is applied to the injector.

WSM000001INI0004US0

PREVENT A FIRE

- Fuel is very flammable and explosive under some conditions. Do not smoke or let flames or sparks in your work area.
- To prevent sparks from an accidental short circuit, always disconnect the battery negative cable first and connect it last.
- The battery gas can cause an explosion. Keep the sparks and open flame away from the top of battery, especially when you charge the battery.
- Make sure that you do not spill fuel on the engine.

WSM000001INI0005US1

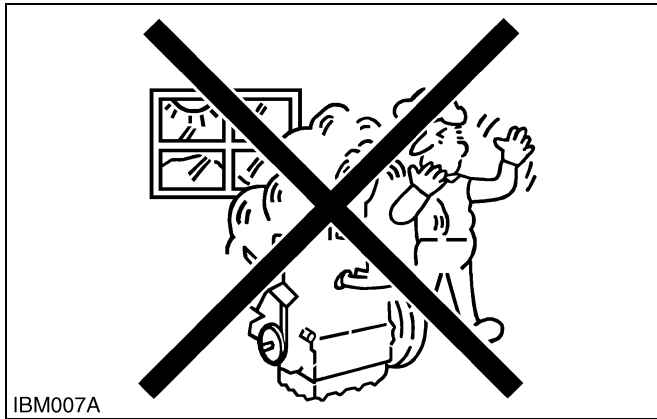

KEEP A GOOD AIRFLOW IN THE WORK AREA

- If the engine is in operation, make sure that the area has good airflow. Do not operate the engine in a closed area. The exhaust gas contains poisonous carbon monoxide.

WSM000001INI0006US1

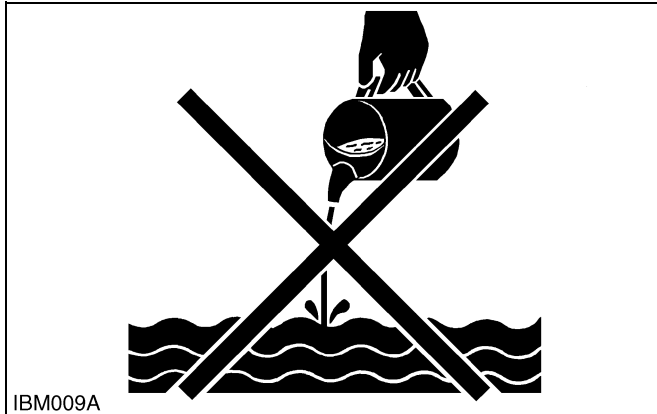

DISCARD FLUIDS CORRECTLY

- Do not discard fluids on the ground, down the drain, into a stream, pond, or lake. Obey related environmental protection regulations when you discard oil, fuel, coolant, electrolyte and other dangerous waste.

WSM000001INI0007US1

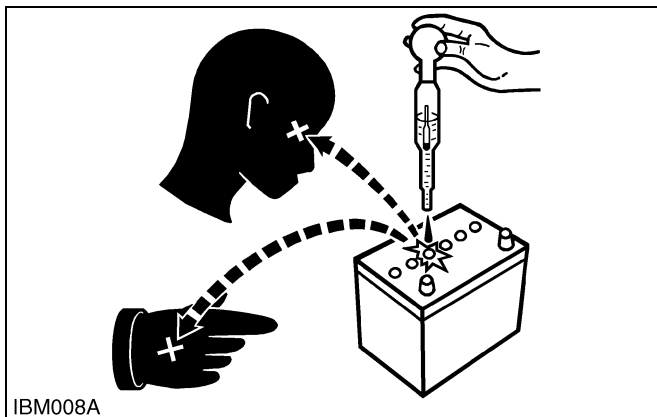

PREVENT ACID BURNS

- Keep electrolyte away from your eyes, hands and clothing. Sulfuric acid in battery electrolyte is poisonous and it can burn your skin and clothing and cause blindness. If you spill electrolyte on yourself, clean yourself with water, and get medical aid immediately.

WSM000001INI0008US1

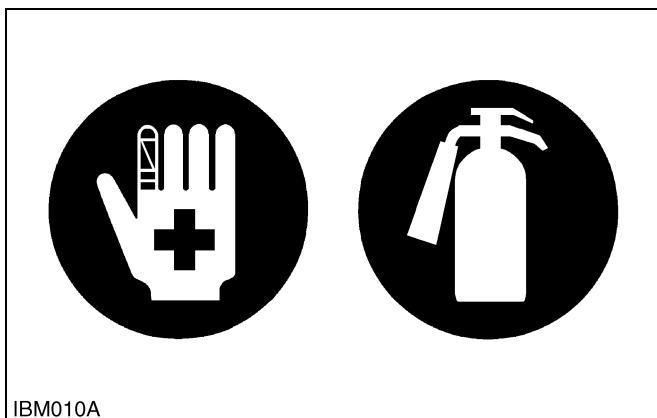

PREPARE FOR EMERGENCIES

- Keep a first aid kit and fire extinguisher ready at all times.
- Keep the emergency contact telephone numbers near your telephone at all times.

WSM000001INI0009US1

2. SPECIFICATIONS

Model	WG752-G-E3	WG752-GL-E3
Number of Cylinder	3	
Type	Vertical, water cooled, 4-cycle Gasoline engine	Vertical, water cooled, 4-cycle Dual Fuel (Gasoline / LPG) engine
		Gasoline fuel LPG fuel
Bore × Stroke	68 x 68 mm (2.68 x 2.68 in.)	
Total Displacement	0.740 L (45.2 cu.in.)	
ISO Net Continuous	13.4 kW / 3600 min ⁻¹ (rpm) 18.0 HP / 3600 min ⁻¹ (rpm)	12.7 kW / 3600 min ⁻¹ (rpm) 17.0 HP / 3600 min ⁻¹ (rpm)
ISO / SAE Net Intermittent	17.1 kW / 3600 min ⁻¹ (rpm) 23.0 HP / 3600 min ⁻¹ (rpm)	16.4 kW / 3600 min ⁻¹ (rpm) 22.0 HP / 3600 min ⁻¹ (rpm)
SAE Gross Intermittent	18.5 kW / 3600 min ⁻¹ (rpm) 24.8 HP / 3600 min ⁻¹ (rpm)	17.7 kW / 3600 min ⁻¹ (rpm) 23.8 HP / 3600 min ⁻¹ (rpm)
Maximum Bare Speed	3850 to 3950 min ⁻¹ (rpm)	
Minimum Bare Idling Speed	1400 to 1600 min ⁻¹ (rpm)	
Cylinder Head	Overhead-Valve	
Ignition System	Full-Transistor (Distributor type)	
Governor	Centrifugal Ball Type Mechanical Governor	
Direction of Rotation	Counter-Clockwise (Viewed from Flywheel)	
Spark Plug	NGK BKR4E-11	
Ignition Timing	0.31 rad (18 °) before T.D.C.	
Firing Order	1-2-3	
Compression Ratio	9.2 : 1	
Lubricating System	Forced Lubrication by Trochoid Pump	
Oil Pressure Indication	Electrical Type Switch	
Lubricating Filter	Full Flow Paper Filter (Cartridge Type)	
Cooling System	Pressurized Radiator (not included in the basic model), Forced Circulation with Water Pump	
Starting System	Electric Starting with Starter (12 V, 0.7 kW)	
Starting Motor	12V, 0.7 kW	
Battery	12 V, 35 AH or Equivalent	
Charging Alternator	12 V, 168 W	
Fuel	*Unleaded Automobile Gasoline	*Standard Commercial LP Gas
Lubricating Oil	Better than SH Class (API) SAE 10W30	
Lubricating Oil Capacity	3.25 L (0.859 U.S.gals)	
Catalytic Muffler / Converter	Three Way Catalyst	
Weight (Dry)	61.7 kg (136 lbs)	
Application	General Power Source	

*The specification described above is of the standard engine of each model.

*Conversion Formula : HP = 0.746 kW, PS = 0.7355 kW

*KUBOTA RECOMMENDED LPG FUEL SPECIFICATIONS

- Commercial Propane gas only.
- Equivalent to Propanes H-D-5 of GPA* standards.

(vol %)

C ₃ H ₈	C ₃ H ₆	C ₄ H ₁₀	Others
≥ 90 %	≤ 5 %	≤ 2.5 %	—

*GPA means Gas Processors Association (U.S.A.)

Model	WG972-G-E3	WG972-GL-E3	
Number of Cylinder	3		
Type	Vertical, water cooled, 4-cycle Gasoline engine	Vertical, water cooled, 4-cycle Dual Fuel (Gasoline / LPG) engine	
		Gasoline fuel	LPG fuel
Bore × Stroke	74.5 x 73.6 mm (2.93 x 2.90 in.)		
Total Displacement	0.962 L (58.7 cu.in.)		
ISO Net Continuous	18.6 kW / 3600 min ⁻¹ (rpm) 25.0 HP / 3600 min ⁻¹ (rpm)	17.5 kW / 3600 min ⁻¹ (rpm) 23.5 HP / 3600 min ⁻¹ (rpm)	
ISO / SAE Net Intermittent	23.1 kW / 3600 min ⁻¹ (rpm) 31.0 HP / 3600 min ⁻¹ (rpm)	22.0 kW / 3600 min ⁻¹ (rpm) 29.5 HP / 3600 min ⁻¹ (rpm)	
SAE Gross Intermittent	24.2 kW / 3600 min ⁻¹ (rpm) 32.5 HP / 3600 min ⁻¹ (rpm)	23.1 kW / 3600 min ⁻¹ (rpm) 31.0 HP / 3600 min ⁻¹ (rpm)	
Maximum Bare Speed	3850 to 3950 min ⁻¹ (rpm)		
Minimum Bare Idling Speed	1400 to 1600 min ⁻¹ (rpm)		
Cylinder Head	Overhead-Valve		
Ignition System	Distributor-Less Solid Stage Type		
Governor	Centrifugal Ball Mechanical Type / Electronic Governor		
Direction of Rotation	Counter-Clockwise (Viewed from flywheel)		
Spark Plug	NGK BKR4E		
Ignition Timing	0.37 rad (21 °) before T.D.C. / 3600 min ⁻¹ (rpm)		
Firing Order	1-2-3		
Compression Ratio	9.2 : 1		
Lubricating System	Forced Lubrication by Trochoid Pump		
Oil Pressure Indication	Electrical Type Switch		
Lubricating Filter	Full Flow Paper Filter (Cartridge Type)		
Cooling System	Pressurized Radiator (not included in the basic model), Forced Circulation with Water Pump		
Starting System	Electric Starting with Starter (12V, 1.0 kW)		
Starting Motor	12V, 1.0 kW		
Battery	12 V, 52 AH or equivalent		
Charging Alternator	12 V, 150 W		
Fuel	*Unleaded Automobile Gasoline	*Standard Commercial LP Gas	
Lubricating Oil	Better than SH Class (API) SAE 10W30		
Lubricating Oil Capacity	3.4 L (0.90 U.S.gals)		
Catalytic Muffler / Converter	Three Way Catalyst		
Weight (Dry)	72.0 kg (159 lbs)		
Application	General Power Source		

*The specification described above is of the standard engine of each model.

*Conversion Formula : HP = 0.746 kW, PS = 0.7355 kW

***KUBOTA RECOMMENDED LPG FUEL SPECIFICATIONS**

- Commercial Propane gas only.
- Equivalent to Propanes H-D-5 of GPA* standards.

(vol %)

C ₃ H ₈	C ₃ H ₆	C ₄ H ₁₀	Others
≥ 90 %	≤ 5 %	≤ 2.5 %	–

*GPA means Gas Processors Association (U.S.A.)

9Y1210571INI0001US0

3. IMPORTANT ITEMS OF EXHAUST EMISSION REGULATION

Along with E3 models, are yet available to be used in the following countries per output category.

kW, Disp.	Model	Type	North America	Europe	Japan
$P \leq 19, 0.225 \leq L$	WG752-G/GL-E3	E3	Available	None Available	Available
$19 < P \leq 30, 0.825 < L \leq 1.0$	WG972-G/GL-E3	E3	Available	Available	None Available

Current and future emission regulations.

Countries		kW, disp.	HC+NO _x /CO (g/kWh)							
			2009	2010	2011	2012	2013	2014	2015	2016
USA	CARB	$P \leq 19, 0.225 \leq L$	8.0/549*							
		$19 < P, L \leq 0.825$	12.0/549	8.0/549*						
		$19 < P, 0.825 < L \leq 1.0$	12.0/549	6.5/375*					0.8/20.6*	
	EPA	$P \leq 19, 0.225 \leq L$	12.1/610	8.0/610*						
		$19 < P \leq 30, L \leq 1.0$	12.1/610	8.0/610*						
Canada		$P \leq 19, 0.225 \leq L$	12.1/610	8.0/610						
Japan		$P < 19, 0.225 \leq L$	12.1/610							
		$19 \leq P < 560$	HC/0.6 g/kWh, NO _x /0.6 g/kWh, CO/20 g/kWh							
EU		$P \leq 19, 0.225 \leq L$	12.1/610							
		$19 < P$	None							

- * : with evaporative emission regulation

9Y1210571INI0016US0

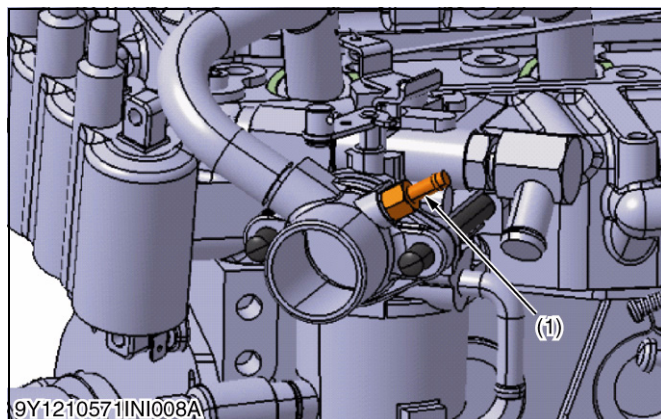

To route running loss emissions into the engine intake system, KUBOTA prepared the purge port on the air-cleaner flange.

- (1) Purge Port

■ IMPORTANT

- There are necessary emission-related items for compliance with emission regulations. Please confirm whether emission-related items are certain on application review (Exhaust Emission Check Sheet).
- For mass-production KUBOTA prepares the installation instructions. These instructions are provided for the final engine assemblers who must ensure the engine, exhaust system (catalyst), intake system, gasoline fuel system and etc, are installed correctly in the engine's certified configuration. Failing to follow these instructions when installing a certified engine in a piece of non-road equipment violates federal law (40CFR 1068. 105(b)), subject to fines or other penalties as described in the Clean Air Act.
- The contractual agreement contract is necessary before mass-production.

9Y1210571INI0018US0

[1] INLET AND EXHAUST SYSTEM

The WG752-G/GL-E3 and WG972-G/GL-E3 engine must use the below air cleaner and inlet pipe, and exhaust back pressure of the muffler must be within the below values.

Part	Part No.
Genuine air cleaner	1G657-1101-1
Genuine inlet pipe	EG561-1164-1

■ Allowable exhaust back pressure at WOT operation

When you use the KUBOTA catalytic converter with non-KUBOTA mufflers, it is necessary to confirm that the exhaust system back pressure is less than allowable limit.

When you use a tail pipe with KUBOTA catalytic muffler, check exhaust system back pressure, too.

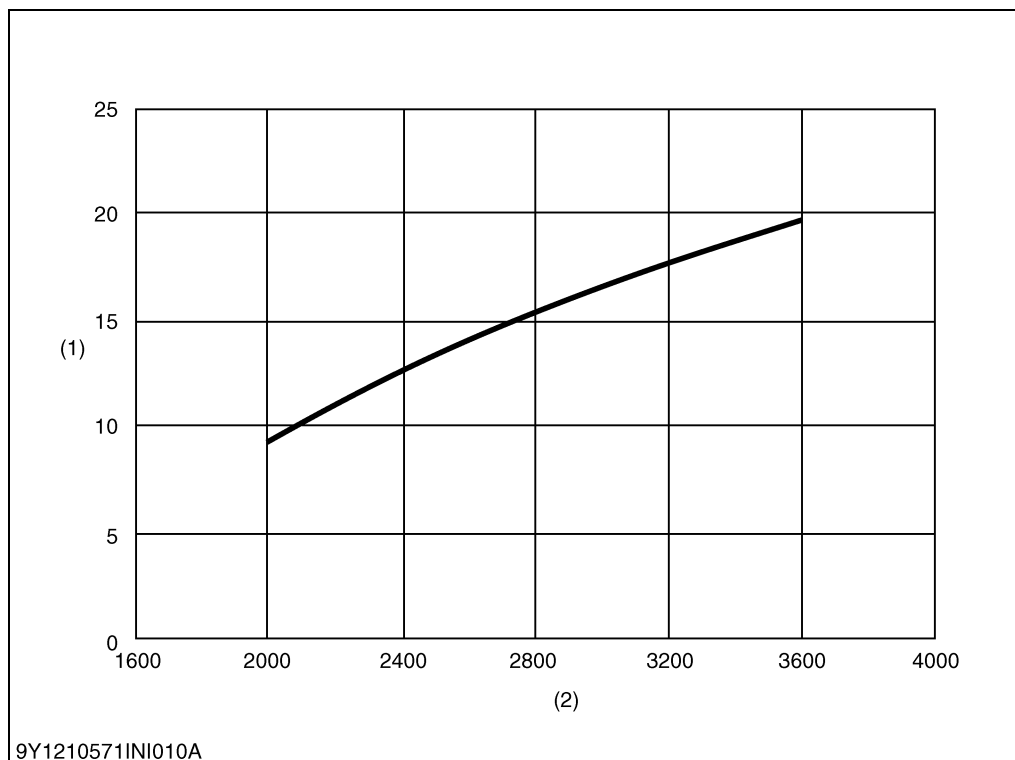

(1) Back Pressure (kPa)
 (2) Engine Speed (min⁻¹ (rpm))

9Y1210571INI010A

Any modifications to the fuel system or any adjustments made on this engine will cause this engine to be in non-compliance with emission regulations.

9Y1210571INI0017US0

[2] ALTITUDE COMPENSATION KIT (WG752-G/GL-E3, WG972-G/GL-E3)

■ IMPORTANT

- EPA and CARB emission regulations require the ultimate user of non-road SI engine, as their obligation, to adjust the emissions by installing the appropriate genuine altitude compensation kit. And the engine manufacturer must provide such kit when engine is operated at an altitude that exceeds the standard level, as guaranteed by the engine manufacturer. For this purpose, KUBOTA prepared genuine altitude compensation kit described below. The ultimate users of SI engine must comply with the regulations through the installation of the appropriate altitude compensation kit for the altitude range where the engine will be operated.
- "Replacement of Altitude Compensation Kit" for reference to the exchange of altitude compensation kit.

Altitude Compensation Kit	Applicable Altitude Ranges
Original Carburetor (with 0 m (0 ft) kit)	0 to 700 m (0 to 2300 ft)
1000 m (3281 ft) compensation kit	300 to 1700 m (984 to 5577 ft)
2000 m (6562 ft) compensation kit	1300 to 2700 m (4265 to 8858 ft)

9Y1210571INI0012US0

[3] LPG REGULATOR WITH VAPORIZER (WG752-GL-E3, WG972-GL-E3)

When operating WG752-GL-E3 and WG972-GL-E3 on LPG, only a KUBOTA GENUINE LPG REGULATOR KIT can be used.

9Y1210571INI0010US0

[4] KUBOTA RECOMMENDED LPG FUEL SPECIFICATIONS

- Commercial Propane gas only.
- Equivalent to Propane H-D-5 of GPA* standards.

C_3H_8	C_3H_6	C_4H_{10}	Others
≥ 90 %	≤ 5 %	≤ 2.5 %	-

*GPA means Gas Processors Association (U.S.A.)

9Y1210318INI0006US0

[5] LENGTH OF THE LPG VAPOR HOSE (WG752-GL-E3, WG972-GL-E3)

The length of the LPG vapor hose between the LPG carburetor and LPG vaporizer must be within 280 to 320 mm (11.1 to 12.5 in.)

9Y1210571INI0013US0

4. PERFORMANCE CURVES

WG752-G-E3

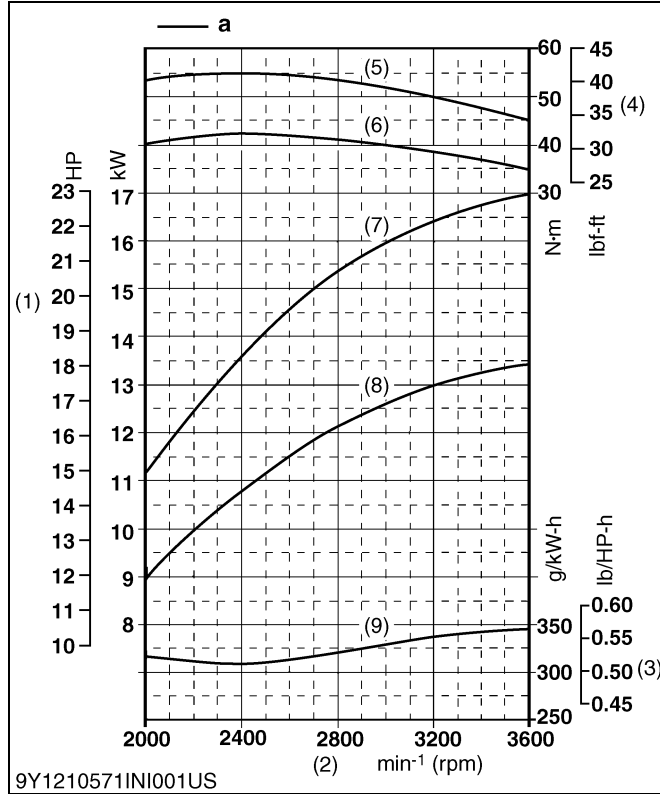

- (1) Brake Horsepower
 - (2) Engine Speed
 - (3) Specific Fuel Consumption
 - (4) Torque
 - (5) Net Intermittent Torque
 - (6) Net Continuous Torque
 - (7) Net Intermittent Brake Horsepower
 - (8) Net Continuous Brake Horsepower
 - (9) Net Intermittent Specific Fuel Consumption
- a : Gasoline Use
b : LP Gas Use

WG752-GL-E3

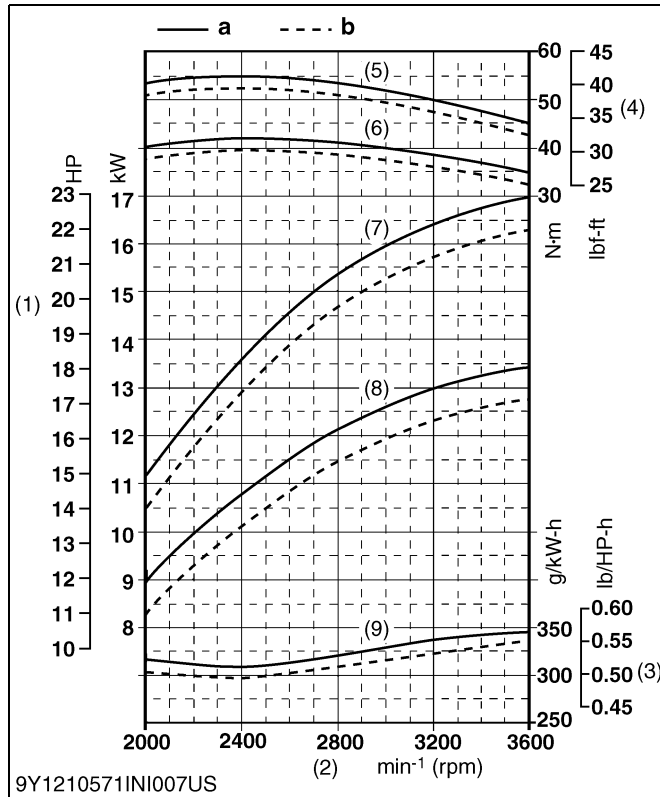

WG972-G-E3

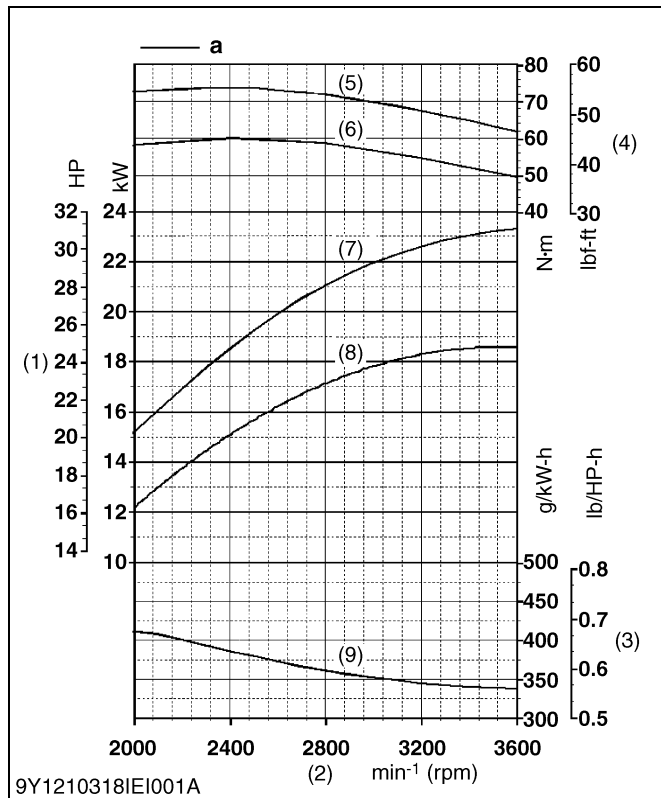

- (1) Brake Horsepower
 - (2) Engine Speed
 - (3) Specific Fuel Consumption
 - (4) Torque
 - (5) Net Intermittent Torque
 - (6) Net Continuous Torque
 - (7) Net Intermittent Brake Horsepower
 - (8) Net Continuous Brake Horsepower
 - (9) Net Intermittent Specific Fuel Consumption
- a : Gasoline Use**
b : LP Gas Use

WG972-GL-E3

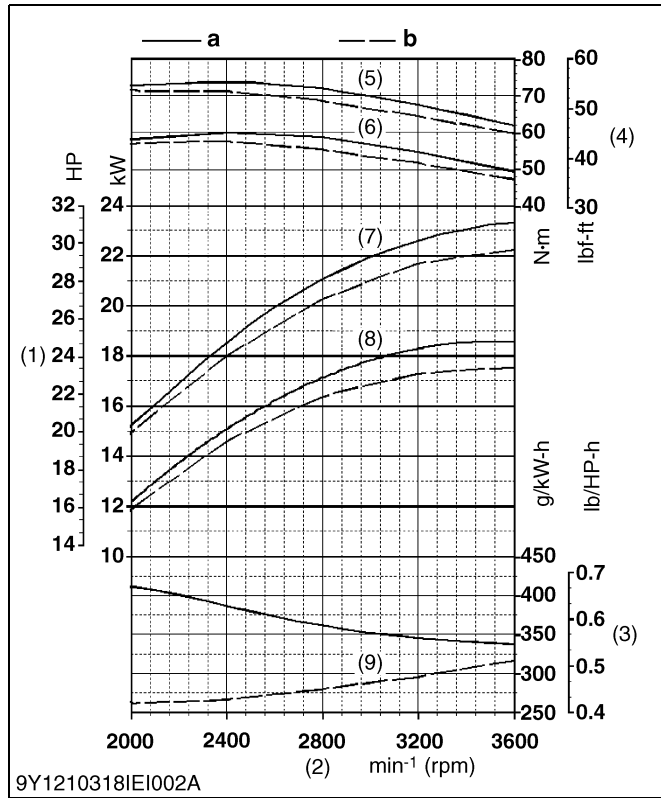

9Y1210571INI0003US0

5. DIMENSIONS

WG752-G/GL-E3

Unit : mm (in.)

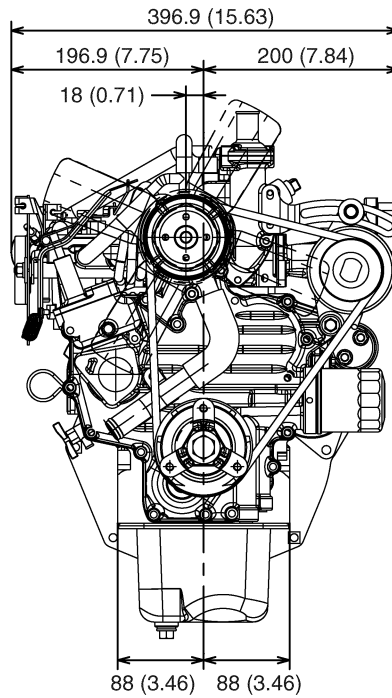

[WG752-G-E3]

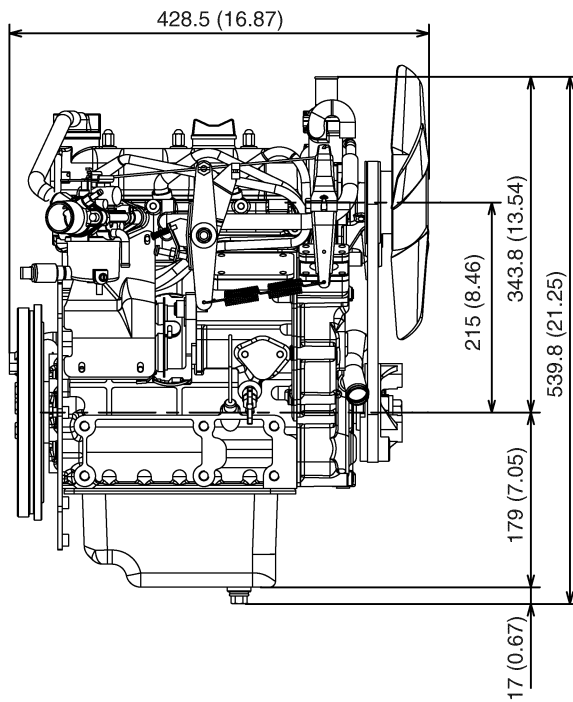

9Y1210571INI002US

[WG752-GL-E3]

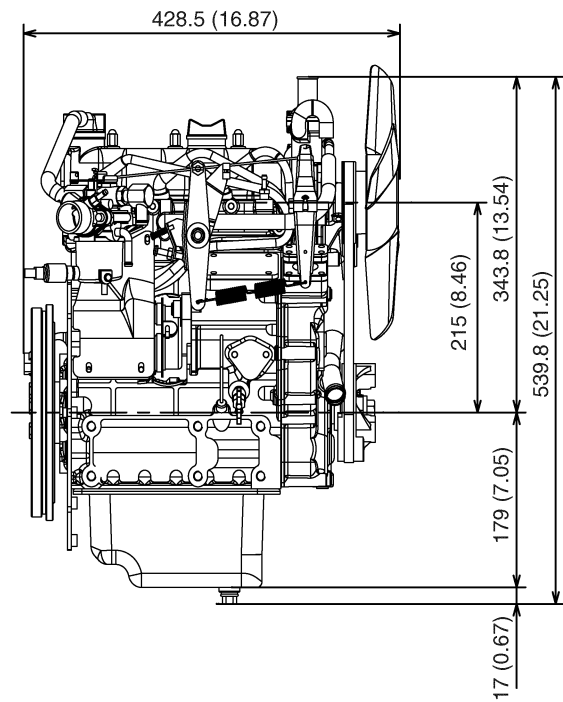

9Y1210571INI0004US0

WG972-G/GL-E3

Unit : mm (in.)

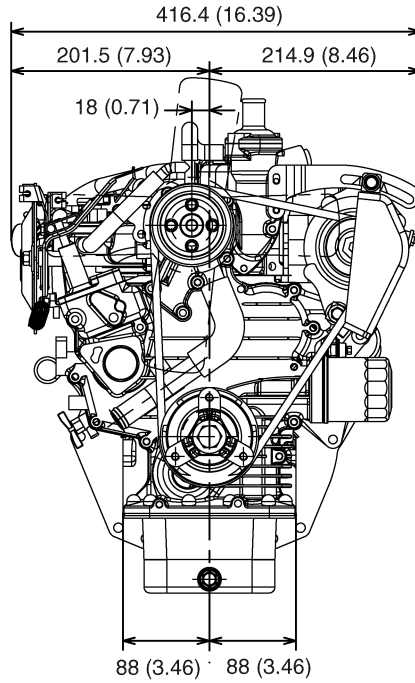

[WG972-G-E3]

[WG972-GL-E3]

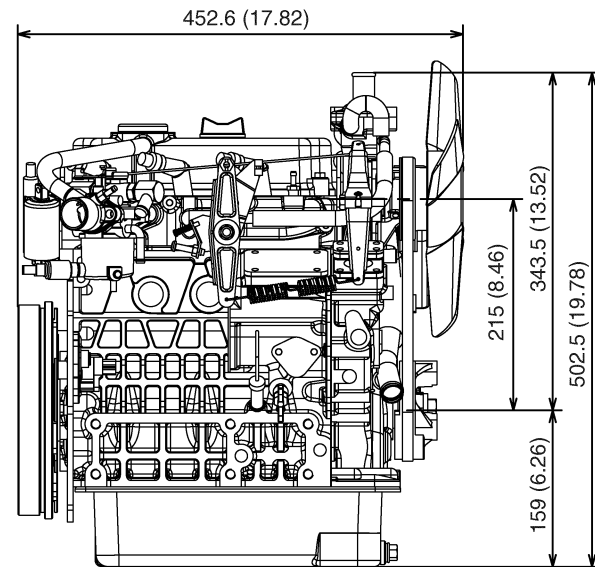
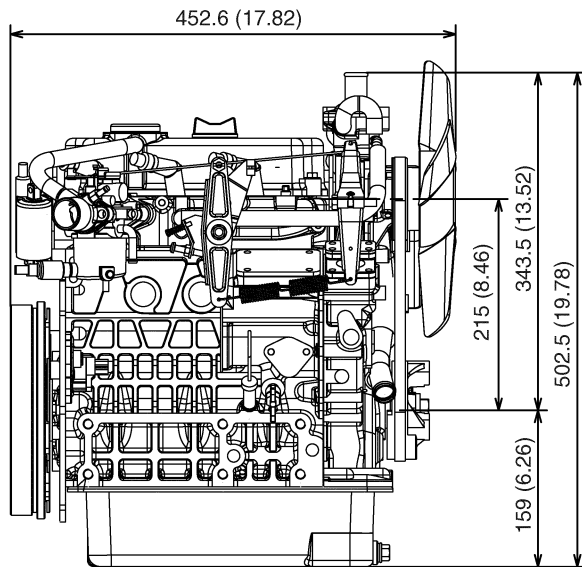

9Y1210571INI004US

9Y1210571INI0006US0

6. WIRING DIAGRAM

WG752-G/GL-E3

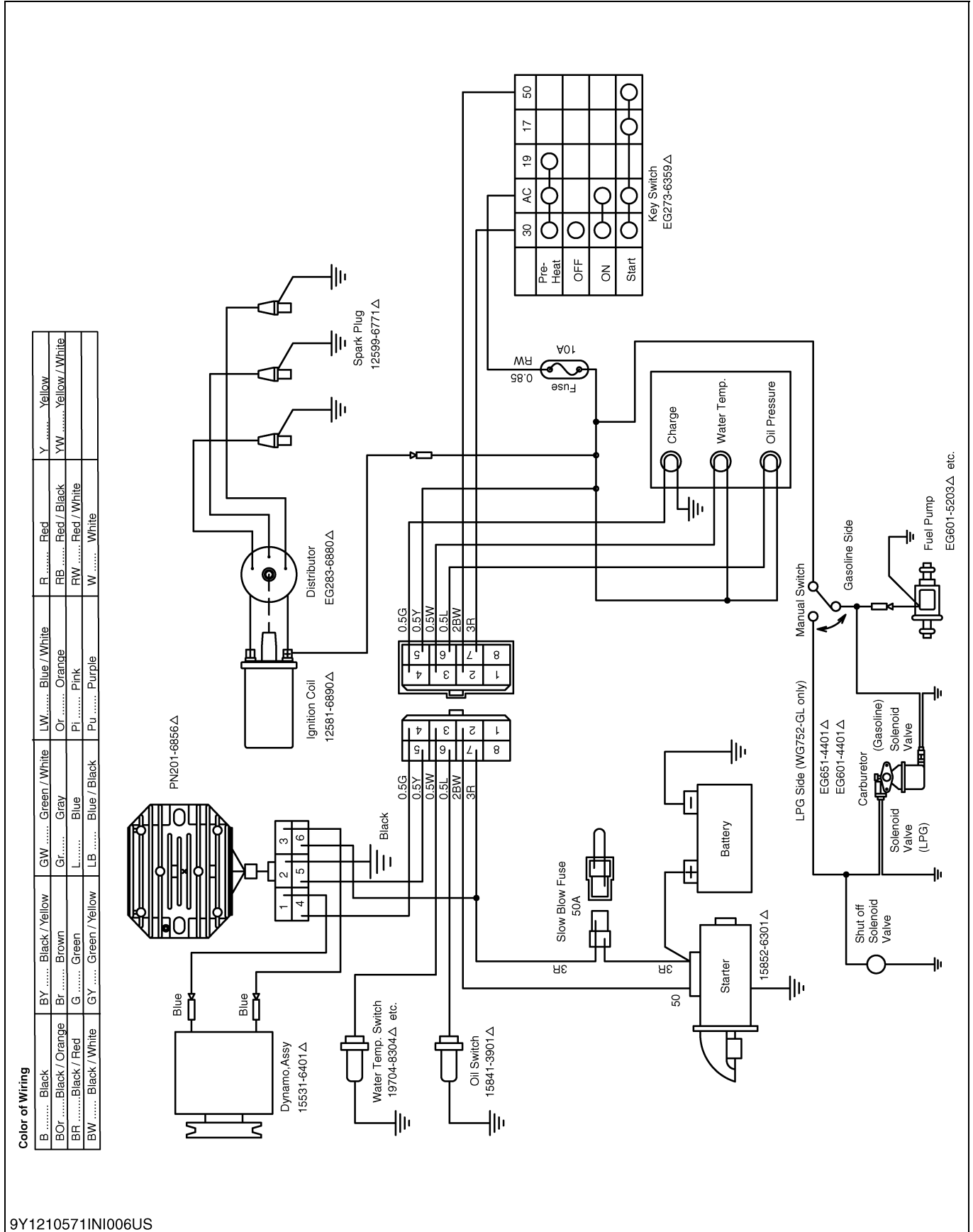

9Y1210571INI006US

9Y1210571INI0015US0

WG972-G/GL-E3

Color of Wiring

B	Black	BY	Black / Yellow	GW	Green / White	LW	Blue / White	R	Red	Y	Yellow
BO	Black / Orange	BR	Brown	GL	Gray	OR	Orange	RB	Red / Black	YW	Yellow / White
BR	Black / Red	G	Green	L	Blue	PI	Pink	RW	Red / White			
BW	Black / White	GY	Green / Yellow	LB	Blue / Black	PU	Purple	W	White			

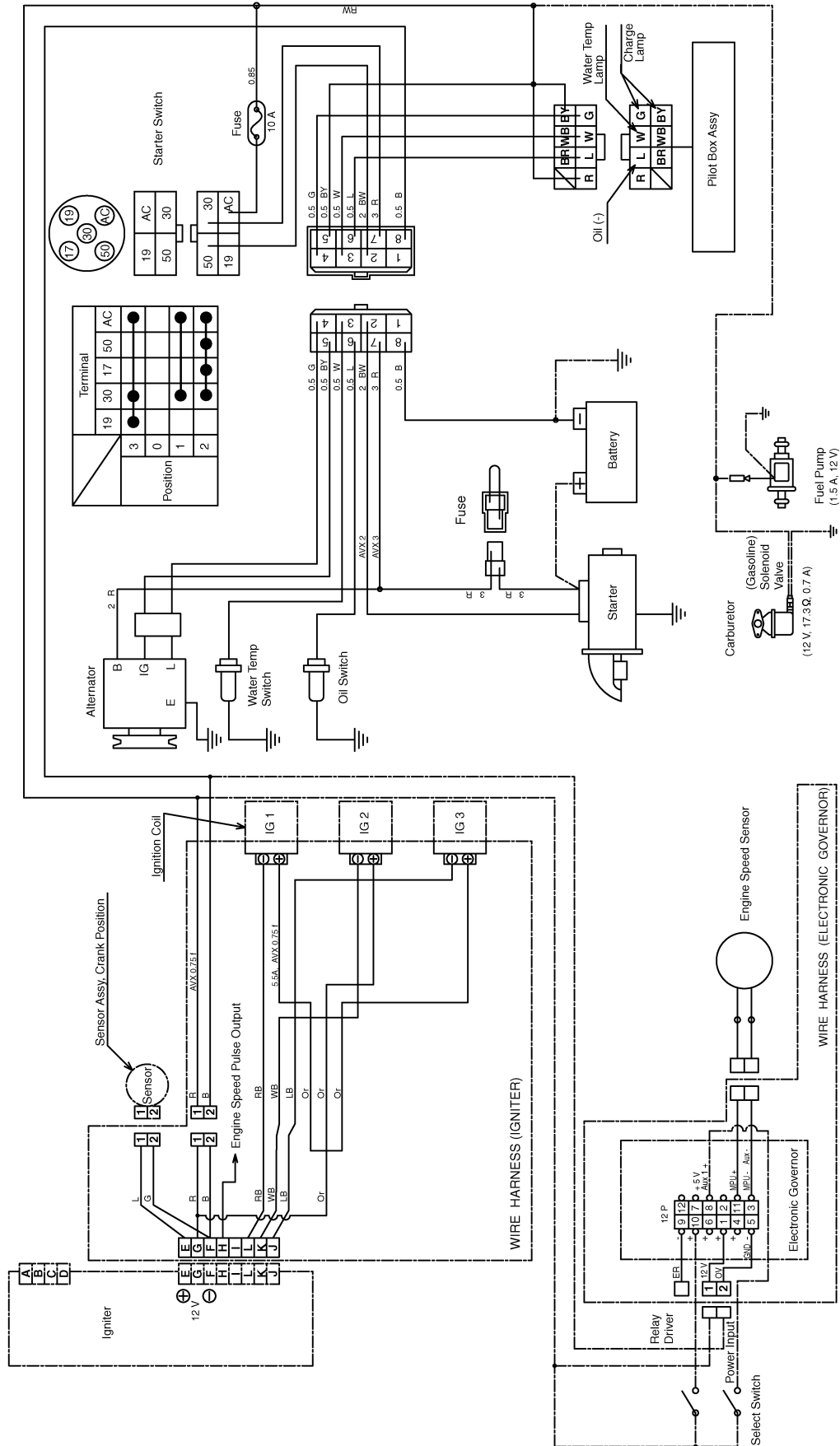

9Y1210318IGI001A

9Y1210571INI0002US0

G GENERAL

GENERAL

CONTENTS

1. ENGINE IDENTIFICATION	G-1
[1] ENGINE MODEL NAME, CODE NUMBER AND ENGINE SERIAL NUMBER	G-1
[2] E3 ENGINE	G-4
[3] CYLINDER NUMBER.....	G-4
[4] CATALYTIC MUFFLER/CONVERTER	G-5
2. GENERAL PRECAUTIONS.....	G-7
3. MAINTENANCE CHECK LIST	G-8
4. CHECK AND MAINTENANCE	G-9
[1] DAILY CHECK POINTS	G-9
[2] CHECK POINTS OF INTIAL 50 HOURS	G-11
[3] CHECK POINTS OF EVERY 50 HOURS	G-12
[4] CHECK POINTS OF EVERY 100 HOURS	G-13
[5] CHECK POINTS OF EVERY 200 HOURS	G-15
[6] CHECK POINTS OF EVERY 1 YEAR.....	G-16
[7] CHECK POINTS OF EVERY 1000 HOURS	G-19
[8] CHECK POINTS OF EVERY AFTER 1000 HOURS.....	G-22
[9] CHECK POINTS OF EVERY 2 YEARS	G-22
5. SPECIAL TOOLS	G-27

1. ENGINE IDENTIFICATION

[1] ENGINE MODEL NAME, CODE NUMBER AND ENGINE SERIAL NUMBER

When contacting the manufacture, always specify your engine model name, code number and serial number. They are necessary to be identified before the engine can be serviced or parts replaced.



■ Engine Model Name and Number Label

The engine model number, the engine serial number and engine code number are written in this label.

- (1) Engine Model Name and Number Label

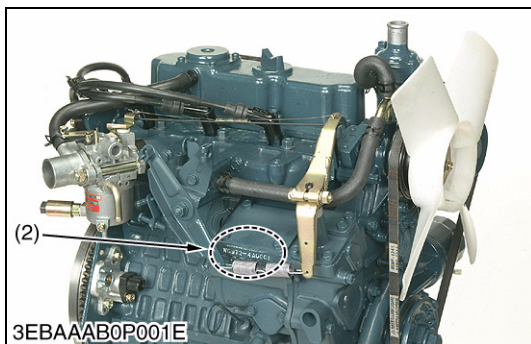

■ Engine Serial Number

The engine serial number is an identified number for the engine. It is marked after the engine model name.

It indicates month and year of manufacture as follows.

Year of manufacture

Alphabet or Number	Year	Alphabet or Number	Year
1	2001	F	2015
2	2002	G	2016
3	2003	H	2017
4	2004	J	2018
5	2005	K	2019
6	2006	L	2020
7	2007	M	2021
8	2008	N	2022
9	2009	P	2023
A	2010	R	2024
B	2011	S	2025
C	2012	T	2026
D	2013	V	2027
E	2014		

- (2) Engine Serial Number

(To be continued)

(Continued)

Month of manufacture

Month	Engine Lot Number	
January	A0001 ~ A9999	B0001 ~ BZ999
February	C0001 ~ C9999	D0001 ~ DZ999
March	E0001 ~ E9999	F0001 ~ FZ999
April	G0001 ~ G9999	H0001 ~ HZ999
May	J0001 ~ J9999	K0001 ~ KZ999
June	L0001 ~ L9999	M0001 ~ MZ999
July	N0001 ~ N9999	P0001 ~ PZ999
August	Q0001 ~ Q9999	R0001 ~ RZ999
September	S0001 ~ S9999	T0001 ~ TZ999
October	U0001 ~ U9999	V0001 ~ VZ999
November	W0001 ~ W9999	X0001 ~ XZ999
December	Y0001 ~ Y9999	Z0001 ~ ZZ999

* Alphabetical letters "I" and "O" are not used.

e.g.

- WG972 - ^(a)B ^{(b)(c)}BA ^(d)A001

- (a) Engine Model Name : **WG972**
- (b) Year : **B** indicates **2011**
- (c) Month : **A** or **B** indicates **January**
- (d) Lot Number : (**0001 ~ 9999** or **A001 ~ Z999**)

9Y1210571GEG0026US0

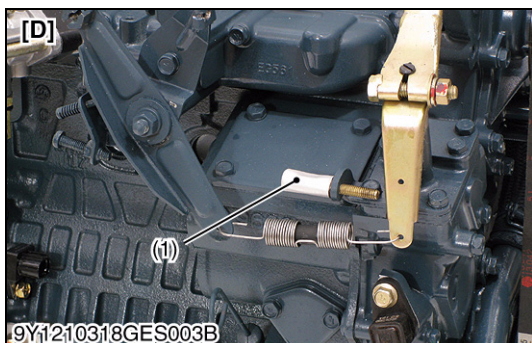
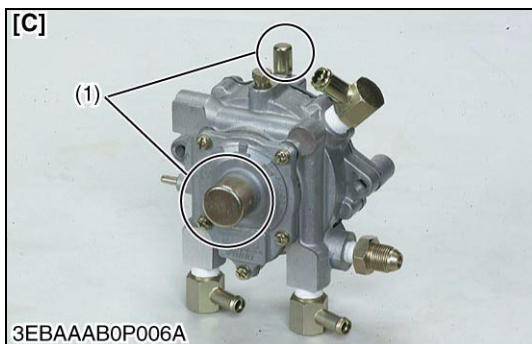
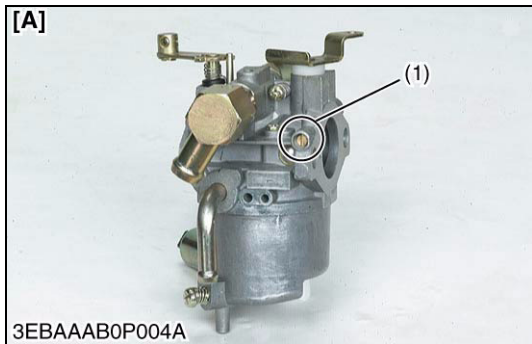

Tamper Resistance

Any modifications to the tamper resistance parts on this engine will cause this engine to be in noncompliance with emission regulations.

(1) Tamper Resistance

- [A] Carburetor**
- [B] Pick-up Sensor (WG972-G/GL-E3)**
- [C] Vaporizer (WG752-G/GL-E3, WG972-G/GL-E3)**
- [D] Governor Lever**
- [E] Distributor (WG752-G/GL-E3)**

9Y1210571GEG0002US0

[2] E3 ENGINE

[Example : Engine Model Name WG972-G-E3-XXXX]

The emission controls previously implemented in various countries to prevent air pollution will be stepped up as Non-Road Emission Standards continue to change. The timing or applicable date of the specific Non-Road Emission regulations depends on the engine displacement and output classification.

Over the past several years, KUBOTA has been supplying SI engines that comply with regulations in the respective countries affected by Non-Road Emission regulations. For KUBOTA Engines, E3 will be the designation that identifies engine models affected by the next emission phase (See the table below).

When servicing or repairing ###-E3 series engines, use only replacement parts for that specific E3 engine, designated by the appropriate E3 KUBOTA Parts List and perform all maintenance services listed in the appropriate KUBOTA Operator's Manual or in the appropriate E3 KUBOTA Workshop Manual. Use of incorrect replacement parts or replacement parts from other emission level engines (for example: E2 engines), may result in emission levels out of compliance with the original E3 design and EPA or other applicable regulations. Please refer to the emission label located on the engine head cover to identify Engine Displacement and Output classification and Emission Control Information. E3 engines are identified with "ET" at the end of the Model designation, on the US EPA label. Please note : E3 is not marked on the engine.

(1)

EMISSION CONTROL INFORMATION	
THIS ENGINE MEETS U.S. EPA EXH REGS FOR 2011 AND CALIFORNIA EXH EMISSION REGULATIONS FOR SI SORES.	
 KUBOTA Corporation	
MODEL : #####(E-ET)	ENGINE DISP. : #####CC
FAMILY : #####	ECS : ###
EPA USEFUL LIFE CATEGORY : A UNLEADED GASOLINE AND COMMERCIAL PROPANE GAS ONLY	
REFER TO OPERATOR'S MANUAL FOR MAINTENANCE SPECIFICATIONS AND ADJUSTMENTS.	
	1H962-1
DEL. ASSY	

9Y1210571GES009A

Category (1)	Displacement and Output classification	EPA Regulation
ET	[A]: SORE Label / Family Name: #KBXS#####	Phase 3
	[B]: LSI Label / Family Name: #KBXB#####	

- (1) "E3" engines are identified with "ET" at the end of the Model designation, on the US EPA label.
"E3" designates Phase 3/Tier 3 models, depending on engine displacement and output classification.

9Y1210571GEG0032US0

(1)

EMISSION CONTROL INFORMATION	
THIS ENGINE MEETS U.S. EPA EXH REGS FOR 2011 AND CALIFORNIA EXH REGULATIONS FOR OFF-ROAD LARGE SI ENGINES.	
 KUBOTA Corporation	
MODEL : #####(E-ET)	ENGINE DISP. : #####CC
FAMILY : #####	ECS : ###
EPA USEFUL LIFE CATEGORY : A UNLEADED GASOLINE AND COMMERCIAL PROPANE GAS ONLY	
REFER TO OPERATOR'S MANUAL FOR MAINTENANCE SPECIFICATIONS AND ADJUSTMENTS.	
	1H962-1
DEL. ASSY	

9Y1210571GES010A

[3] CYLINDER NUMBER

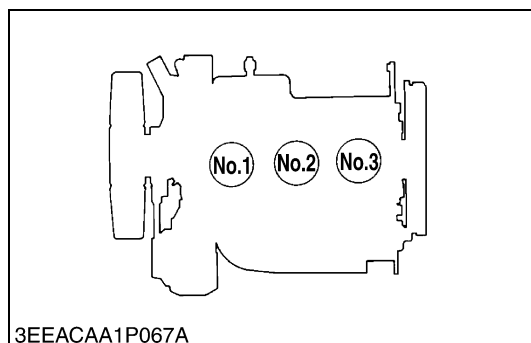

The cylinder numbers of KUBOTA gasoline, gasoline / LPG and natural gas engine are designated as shown in the figure.

The sequence of cylinder numbers is given as No.1, No.2 and No.3 starting from the gear case side.

9Y1210318GEG0006US0

[4] CATALYTIC MUFFLER/CONVERTER

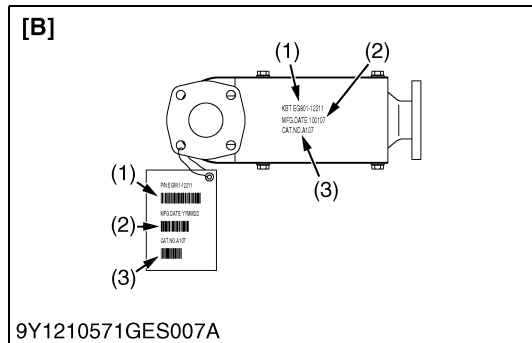
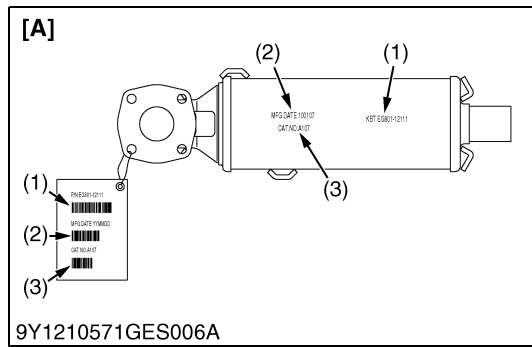

KUBOTA provides the catalytic muffler and converter as the catalyst parts.

The parts number, the manufacturing date and the catalyst lot number are marked on surfaces of the catalyst parts as the catalyst identification.

NOTE

- **New service catalytic muffler/converter has the bar code tag of the catalyst identification as the figure.**
- **Catalyst identification are catalyst lot number, parts number and manufacturing date.**
- **Engine identification are engine model name, code number and serial number.**

IMPORTANT

- **To trace of the catalytic muffler/converter, put down the catalyst identification and engine identification when new service catalytic muffler/converter is installed.**

- (1) Part Number (3) Catalyst Lot Number
 (2) Manufacturing Date

Manufacturing Date (YYMMDD)

YY	Year	MM	Month	DD	Day
09	2009	01	January	01	1
10	2010	02	February	02	2
11	2011	03	March	03	3
12	2012	04	April	04	4
13	2013	05	May	05	5
14	2014	06	June	06	6
15	2015	07	July	07	7
16	2016	08	August	08	8
17	2017	09	September	09	9
18	2018	10	October	10	10
19	2019	11	November	11	11
20	2020	12	December	12	12
21	2021			13	13
22	2022			14	14
23	2023			15	15
24	2024			⋮	⋮
25	2025			⋮	⋮
26	2026			⋮	⋮
27	2027			31	31

e.g.

- (a)(b)(c)
110104

- (a) Year : **11** indicates **2011**
 (b) Month : **01** indicates **January**
 (c) Day : **04** indicates **4**

[A] CATALYTIC MUFFLER
 [B] CATALYTIC CONVERTER

(To be continued)

(Continued)

Catalyst Lot Number (YMDD)

YY	Year	MM	Month	DD	Day
9	2009	1	January	01	1
A	2010	2	February	02	2
B	2011	3	March	03	3
C	2012	4	April	04	4
D	2013	5	May	05	5
E	2014	6	June	06	6
F	2015	7	July	07	7
G	2016	8	August	08	8
H	2017	9	September	09	9
J	2018	A	October	10	10
K	2019	B	November	11	11
L	2020	C	December	12	12
M	2021			13	13
N	2022			14	14
P	2023			15	15
R	2024			⋮	⋮
S	2025			⋮	⋮
T	2026			⋮	⋮
V	2027			31	31

e.g.

(a)(b)(c)

- A C 21

- (a) Year : **A** indicates **2010**
 (b) Month : **C** indicates **December**
 (c) Day : **21** indicates **21**

9Y1210571GEG0033US0

2. GENERAL PRECAUTIONS

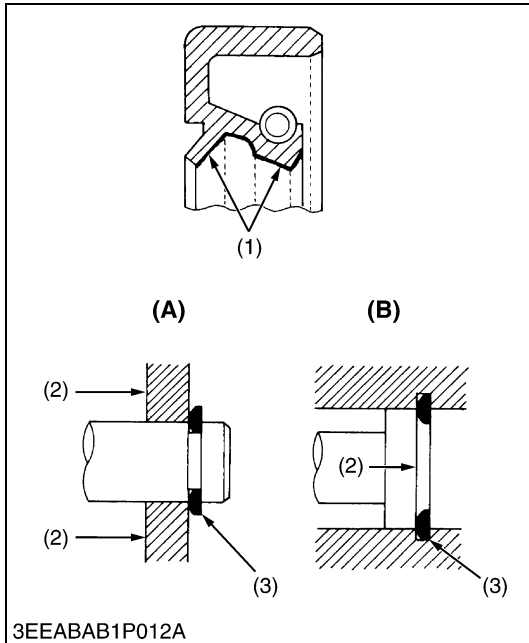

- During disassembly, carefully arrange removed parts in a clean area to prevent confusion later. Screws, bolts and nuts should be replaced in their original position to prevent reassembly errors.
- When special tools are required, use KUBOTA genuine special tools. Special tools which are not frequently used should be made according to the drawings provided.
- Before disassembling or servicing live wires, make sure to always disconnect the grounding cable from the battery first.
- Remove oil and dirt from parts before measuring.
- Use only KUBOTA genuine parts for parts replacement to maintain engine performance and to ensure safety.
- Gaskets and O-rings must be replaced during reassembly. Apply grease to new O-rings or oil seals before assembling.
- When reassembling external or internal snap rings, position them so that sharp edge faces against the direction from which a force is applied.
- Be sure to perform run-in the serviced or reassemble engine. Do not attempt to give heavy load at once, or serious damage may result to the engine.

- (1) Grease
 - (2) Force
 - (3) Place the Sharp Edge the Direction of Force
- (A) External Snap Ring
 - (B) Internal Snap Ring

9Y1210318GEG0007US0

3. MAINTENANCE CHECK LIST

To maintain long-lasting and safe engine performance, make it a rule to carry out regular inspections by following the table below. (The schedule applies to an engine in use under normal conditions.)

[WG752-G/GL-E3, WG972-G/GL-E3]

Item	Service Interval							
	Daily	Every 50 hrs	Every 100 hrs	Every 200 hrs	Every 1 year	Every 1000 hrs	Every after 1000 hrs	Every 2 years
Checking engine oil level	☆							
Checking and replenish coolant	☆							
Checking air cleaner element	if necessary							
Checking LPG tank setting condition	if necessary							
Checking LPG fuel connector	☆							
Cleaning air cleaner element		☆						
Checking gasoline fuel hose and clamp bands		☆						
Checking LPG fuel hose and clamp bands		☆						
LPG fuel check		☆						
Checking battery electrolyte level		☆						
Cleaning spark plug			☆					
Checking fuel filter			☆					
Check fan belt tension and damage			☆					
Changing engine oil		★		☆				
Replacing oil filter cartridge		★		☆				
Checking LPG tank setting condition				☆				
Checking radiator hoses and clamp bands				☆				
* Replacing air cleaner element					☆			
Replacing gasoline fuel hose, clamp bands and fuel filter					☆			
Cleaning fuel tank inside					☆			
Cleaning water jacket and radiator interior					☆			
Replacing spark plug						☆		
Checking coolant hose of LPG vaporizer						☆		
Checking vacuum lock hose of LPG vaporizer						☆		
Draining tar						☆		
Checking valve clearance						☆		
Cleaning combustion chamber							if necessary	
Replacing intake air line								☆
Replacing breather hose								☆
Replacing LPG fuel hose and clamp bands								☆
Replacing coolant hose of LPG vaporizer								☆
Replacing vacuum lock hose of LPG vaporizer								☆
Checking primary chamber								☆
Checking air tight of secondary chamber								☆
Checking vacuum lock system								☆
Replacing radiator hoses and clamp bands								☆
Replacing battery								☆
Replacing ignition wires								☆
Changing radiator coolant (L.L.C.)					☆			

★ Change engine oil and replace oil filter cartridge after the first 50 hours of operation.

* Replace the element after 6 times cleaning.



CAUTION

- When changing or inspecting, be sure to level and stop the engine.

4. CHECK AND MAINTENANCE

[1] DAILY CHECK POINTS

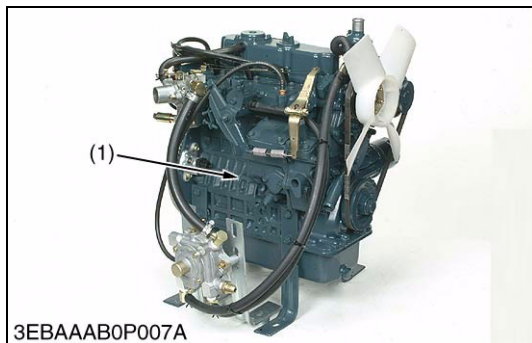

Checking Engine Oil Level

1. Level the engine.
2. To check the oil level, draw out the dipstick (1), wipe it clean, reinsert it, and draw it out again.
Check to see that the oil level lies between the two notches.
3. If the level is too low, add new oil to the specified level.

■ IMPORTANT

- When using an oil of different maker or viscosity from the previous one, drain old oil. Never mix two different types of oil.
- Use the proper SAE Engine oil according to ambient temperatures.

■ NOTE

- Be sure to inspect the engine, locating it on a horizontal place. If placed on gradients, accurately, oil quantity may not be measured.
- Be sure to keep the oil level between upper and lower limits of the dipstick. Too much oil may cause a drop in output or excessive blow-by gas. On the closed breather type engine in which mist is sucked through port, too much oil may caused oil hammer. While too little oil, may seize the engine's rotating and sliding parts.

(1) Dipstick

9Y1210318GEG0010US0

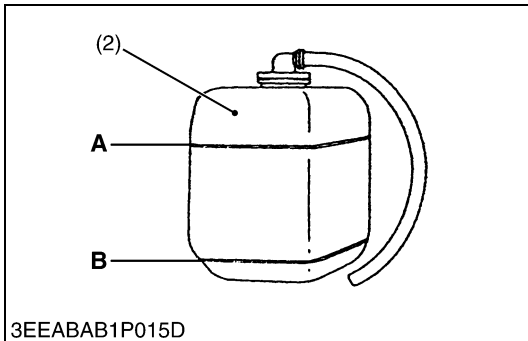
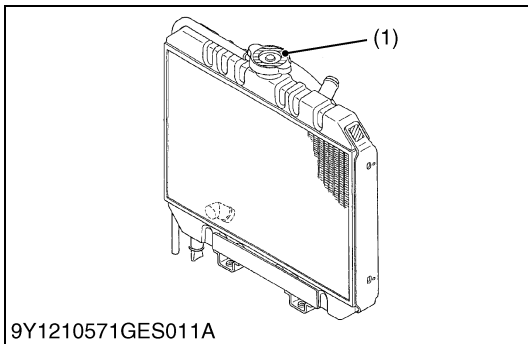

Checking and Replenish Coolant

- Without recovery tank :
Remove the radiator cap (1) and check to see that the coolant level is just below the port.
With recovery tank (2) :
Check to see that the coolant level lies between **FULL "A"** and **LOW "B"**.
- If coolant level is too low, check the reason for decreasing coolant.
(Case 1)
If coolant is decreasing by evaporation, replenish only fresh, soft water.
(Case 2)
If coolant is decreasing by leak, replenish coolant of the same manufacture and type in the specified mixture ratio (fresh, soft water and L.L.C.). If the coolant brand cannot be identified, drain out all of the remaining coolant and refill with a totally new brand of coolant mix.

⚠ CAUTION

- Do not remove the radiator cap until coolant temperature is below its boiling point. Then loosen the cap slightly to relieve any excess pressure before removing the cap completely.
- IMPORTANT**
- During filling the coolant, air must be vented from the engine coolant passages. The air vents by jiggling the radiator upper and lower hoses.
- Be sure to close the radiator cap securely. If the cap is loose or improperly closed, coolant may leak out and the engine could overheat.
- Do not use an antifreeze and scale inhibitor at the same time.
- Never mix the different type or brand of L.L.C..

- | | |
|-------------------|----------|
| (1) Radiator Cap | A : FULL |
| (2) Recovery Tank | B : LOW |

9Y1210571GEG0037US0

Checking Air Cleaner Element (If necessary)

- Remove the dust cup in the air cleaner.
- Check the dust in the dust cup and the element.

(When reassembling)

- Install the air cleaner dust cup with **"TOP"** indicated on the rear of the cup.

- | | |
|--------------|----------------|
| (1) Element | (3) "TOP" Mark |
| (2) Dust Cap | |

9Y1210571GEG0038US0

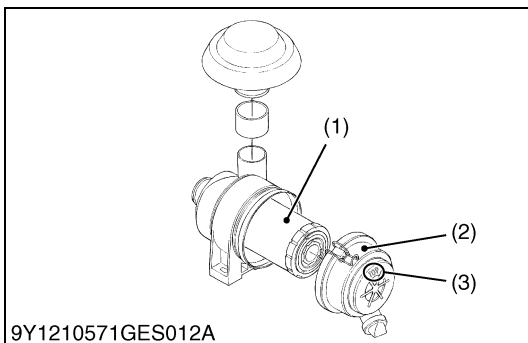

Checking LPG Tank Setting Condition (If necessary) (WG752-GL-E3, WG972-GL-E3)

- Check the setting condition of LPG fuel tank.

9Y1210571GEG0005US0

Checking LPG Fuel Connector (WG752-GL-E3, WG972-GL-E3)

- Check the connector of LPG line (hoses and clamps).

9Y1210571GEG0006US0

[2] CHECK POINTS OF INTIAL 50 HOURS

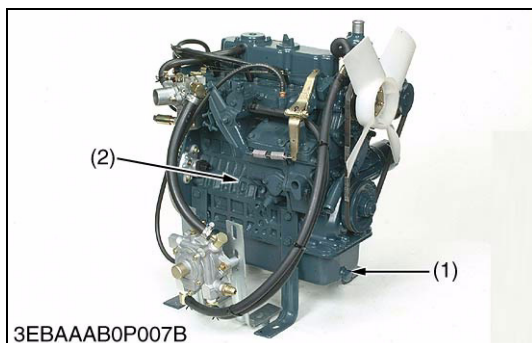

Changing Engine Oil

⚠ CAUTION

- **Be sure to stop engine before changing engine oil.**
1. Start and warm up the engine for approx. 5 minutes.
 2. Place an oil pan underneath the engine.
 3. To drain the used oil, remove the drain plug (1) at the bottom of the engine and drain the oil completely.
 4. Screw the drain plug (1).
 5. Fill new oil up to upper line on the dipstick (2).

■ IMPORTANT

- **When using an oil of different maker or viscosity from the previous one, remove all of the old oil.**
- **Never mix two different types of oil.**
- **Engine oil should have properties of API classification better than SH.**
- **Use the proper SAE Engine Oil according to ambient temperature.**

Above 25 °C (77 °F)	SAE30 or SAE10W-30
0 °C to 25 °C (32 °F to 77 °F)	SAE20 or SAE10W-30
Below 0 °C (32 °F)	SAE10W or SAE10W-30

Engine oil capacity	WG752-G/GL-E3	3.25 L 0.859 U.S.gals
	WG972-G/GL-E3	3.4 L 0.90 U.S.gals

Tightening torque	Drain plug	33 to 37 N·m 3.3 to 3.8 kgf·m 24 to 27 lbf·ft
-------------------	------------	---

(1) Drain Plug

(2) Dipstick

9Y1210571GEG0030US0



Replacing Oil Filter Cartridge

⚠ CAUTION

- **Be sure to stop the engine before changing filter cartridge.**
1. Remove the oil filter cartridge (1) with the filter wrench.
 2. Apply a slight coat of oil onto the new cartridge gasket.
 3. To install the new cartridge, screw it in by hand. Over tightening may cause deformation of rubber gasket.
 4. After the new cartridge has been replaced, the engine oil normally decrease a little. Thus see that the engine oil does not leak through the seal and be sure to read the oil level on the dipstick. Then, replenish the engine oil up to the specified level.

■ IMPORTANT

- **To prevent serious damage to the engine, replacement element must be highly efficient. Use only a KUBOTA genuine filter or its equivalent.**

(1) Engine Oil Filter Cartridge

9Y1210318GEG0018US0

[3] CHECK POINTS OF EVERY 50 HOURS



3EEAEAB1P006A

Cleaning Air Cleaner Element

1. To clean the element, use clean dry compressed air on the inside of the element.
Air pressure at the nozzle must be under 210 kPa (2.1 kgf/cm², 30 psi).
2. If the element is stained with carbon or oil, replace the element.

■ IMPORTANT

- Make sure the wing bolt for the element is tight enough. If it is loose, dust and dirt may be sucked, wearing down the cylinder liner and piston ring earlier and thereby resulting in poor power output.
- Do not overservice the air cleaner element.

■ NOTE

- Replace the element once a year or every 6th cleaning.

9Y1210318GEG0019US0

⚠ CAUTION

- Stop the engine when attempting the check and replace prescribed below.
- Remember to check the fuel line periodically. The fuel line is subject to wear and aging, fuel may leak out onto the running engine, causing a fire.

9Y1210318GEG0020US0

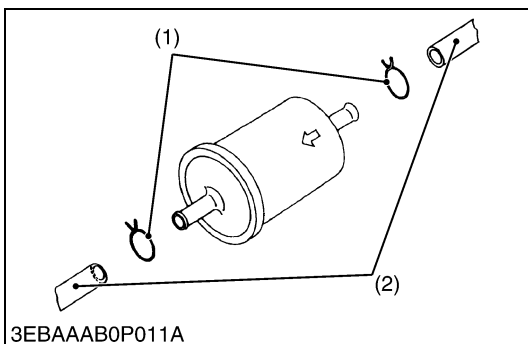

3EBAAAB0P011A

Checking Gasoline Fuel Hose and Clamp Bands

Check the fuel hoses every 50 hours of operation.

1. Since the fuel hose (2) is made of rubber, it ages regardless of the period of service.
Replace the fuel hose together with the clamp every two years.
2. However, if the fuel hose and clamp are found to be damaged or deteriorate earlier than two years, then replace or remedy.
3. After the fuel hose and the clamp have been replaced, bleed the fuel system.

(1) Clamp

(2) Fuel Hose

9Y1210571GEG0008US0

Checking LPG Fuel Hose and Clamp Bands (WG752-GL-E3, WG972-GL-E3)

■ IMPORTANT

- Never test for gas leaks with a FLAME.

■ NOTE

- Check for fuel leakage with soapy water or gas-detector, if leakage is found, correct leakage or replace the hose.

9Y1210571GEG0009US0

LPG Fuel Check (WG752-GL-E3, WG972-GL-E3)

1. Open the shut off solenoid valve on the tank.
2. Check for
 - a) Fuel tank to filter
 - b) Filter to shut off solenoid valve
 - c) Shut off solenoid valve to vaporizer

9Y1210571GEG0029US0

Checking Battery Electrolyte Level

1. Check the battery electrolyte level.
2. If the level is below than lower level line, add the distilled water to pour level of each cell.

⚠ CAUTION

- Never remove the vent plugs while the engine is running.
- Keep electrolyte away from eyes, hands and clothes. If you are spattered with it, wash it away completely with water immediately and get medical attention.
- Wear eye protection and rubber gloves when working around battery.

9Y1210318GEG0026US0

[4] CHECK POINTS OF EVERY 100 HOURS

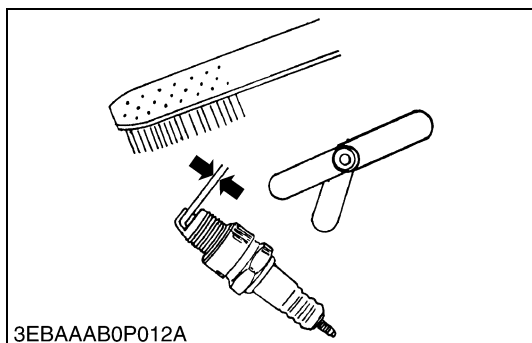

3EBAAAB0P012A

Cleaning Spark Plug Gap

1. Remove the spark plug, and remove carbon from the electrode with a wire brush or other tools.
2. Measure the spark plug gap with a feeler gauge, and repair or replace the spark plug if the measured gap differs from the factory specification.
3. Replace the spark plug if the electrode or the insulator is deformed or cracked.
4. Tighten the spark plug with a plug wrench.

■ IMPORTANT (When reassembling)

- Put the high tension cord cap inside the spark plug terminal firmly.
- Make sure that the cylinder number is corresponding to the high tension cord number.
- Wrong connection causes high temperature on catalytic muffler/converter.

Spark plug gap	Factory specification	WG752-G/GL-E3	1.0 to 1.1 mm 0.040 to 0.043 in.
		WG972-G/GL-E3	0.60 to 0.70 mm 0.024 to 0.027 in.

Spark plug	WG752-G/GL-E3	NGK BKR4E-11
	WG972-G/GL-E3	NGK BKR4E

Tightening torque	Spark plug	20 to 24 N·m 2.0 to 2.5 kgf·m 15 to 18 lbf·ft
-------------------	------------	---

9Y1210571GEG0027US0

Checking Fuel Filter

1. Check the fuel filter.
2. If the fuel filter is dirty, clean it or replace it.

⚠ CAUTION

- Stop the engine when attempting to check and clean the fuel filter.
- Gasoline fuel is extremely flammable, so avoid fires.

9Y1210318GEG0028US0

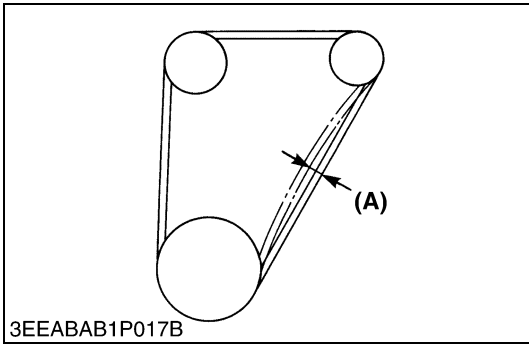

Fan Belt Tension

1. Measure the deflection **(A)**, depressing the belt halfway between the fan drive pulley and alternator pulley at specified force 98 N (10 kgf, 22 lbf).
2. If the measurement is not within the factory specifications, loosen the alternator mounting screws and relocate the alternator to adjust.

Deflection (A)	Factory specification	7.0 to 9.0 mm 0.28 to 0.35 in.
-----------------------	-----------------------	-----------------------------------

(A) Deflection

9Y1210318GEG0001US0

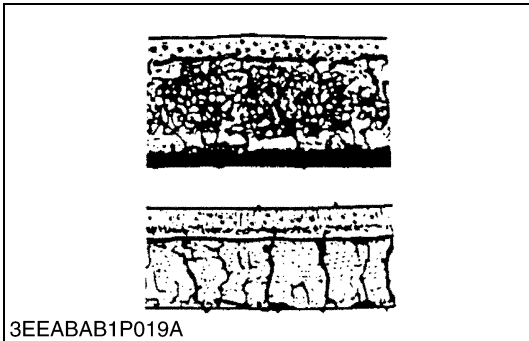

Fan Belt Damage and Wear

1. Check the fan belt for damage.
2. If the fan belt is damaged, replace it.
3. Check if the fan belt is worn and sunk in the pulley groove.
4. If the fan belt is nearly worn out and deeply sunk in the pulley groove, replace it.

(A) Good

(B) Bad

9Y1210318GEG0002US0

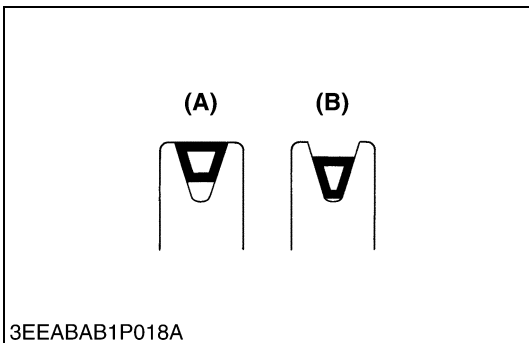

[5] CHECK POINTS OF EVERY 200 HOURS

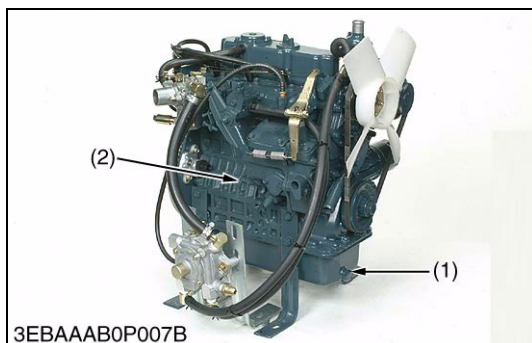

Changing Engine Oil

⚠ CAUTION

- **Be sure to stop engine before changing engine oil.**
1. Start and warm up the engine for approx. 5 minutes.
 2. Place an oil pan underneath the engine.
 3. To drain the used oil, remove the drain plug (1) at the bottom of the engine and drain the oil completely.
 4. Screw the drain plug (1).
 5. Fill new oil up to upper line on the dipstick (2).

■ IMPORTANT

- **When using an oil of different maker or viscosity from the previous one, remove all of the old oil.**
- **Never mix two different types of oil.**
- **Engine oil should have properties of API classification better than SH.**
- **Use the proper SAE Engine Oil according to ambient temperature.**

Above 25 °C (77 °F)	SAE30 or SAE10W-30
0 °C to 25 °C (32 °F to 77 °F)	SAE20 or SAE10W-30
Below 0 °C (32 °F)	SAE10W or SAE10W-30

Engine oil capacity	WG752-G/GL-E3	3.25 L 0.859 U.S.gals
	WG972-G/GL-E3	3.4 L 0.90 U.S.gals

Tightening torque	Drain plug	33 to 37 N·m 3.3 to 3.8 kgf·m 24 to 27 lbf·ft
-------------------	------------	---

(1) Drain Plug

(2) Dipstick

9Y1210571GEG0030US0



Replacing Engine Oil Filter Cartridge

⚠ CAUTION

- **Be sure to stop the engine before changing filter cartridge.**
1. Remove the oil filter cartridge (1) with the filter wrench.
 2. Apply a slight coat of oil onto the new cartridge gasket.
 3. To install the new cartridge, screw it in by hand. Over tightening may cause deformation of rubber gasket.
 4. After the new cartridge has been replaced, the engine oil normally decrease a little. Thus see that the engine oil does not leak through the seal and be sure to read the oil level on the dipstick. Then, replenish the engine oil up to the specified level.

■ IMPORTANT

- **To prevent serious damage to the engine, replacement element must be highly efficient. Use only a KUBOTA genuine filter or its equivalent.**

(1) Engine Oil Filter Cartridge

9Y1210318GEG0030US0

Checking LPG Tank Setting Condition (WG752-G/L-E3, WG972-G/L-E3)

1. Check the setting condition of LPG fuel tank.

9Y1210571GEG0001US0

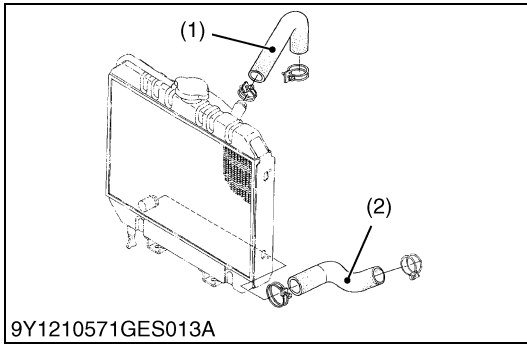

Checking Radiator Hoses and Clamp Bands

1. Check to see if the radiator hoses are properly fixed every 200 hours of operation or every six months, whichever comes first.
2. If the clamp is loose, apply oil to the threads and retighten it securely.
3. The coolant hose is made of rubber and tends to age. It must be replaced every two years. Also replace the clamp and tighten it securely.

(1) Upper Hose

(2) Lower Hose

9Y1210571GEG0039US0

[6] CHECK POINTS OF EVERY 1 YEAR

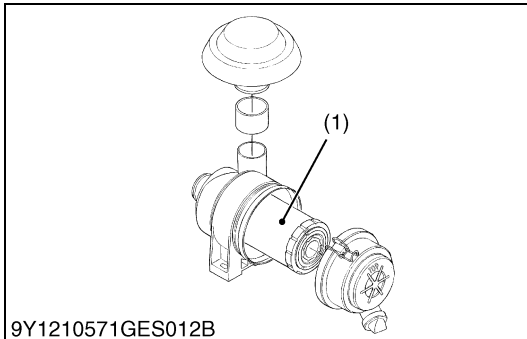

Replacing Air Cleaner Element

1. Remove the dust cup from the air cleaner.
2. After cleaning the dust cup, remove the air cleaner element.
3. Replace the new air cleaner element.

(1) Air Cleaner Element

9Y1210571GEG0040US0

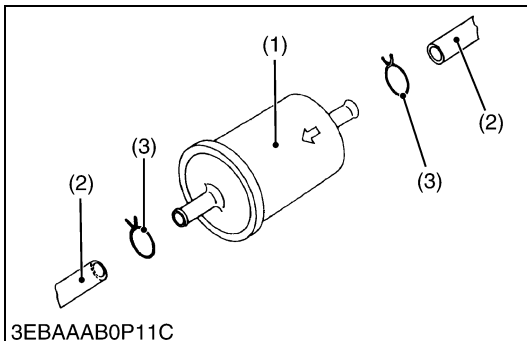

Replacing Gasoline Fuel Hose, Clamp Bands and Fuel Filter

1. Close the fuel tank cock.
2. Replace the fuel filter (1) with a new one.
3. Replace the hose (2) and clamp (3).

(1) Fuel Filter

(3) Clamp

(2) Fuel Hose

9Y1210571GEG0012US0

Cleaning Fuel Tank Inside (for Gasoline Fuel)

1. Following the unit / machine's operators manual, drain the gasoline fuel in the fuel tank.
2. Clean the fuel tank inside.

9Y1210318GEG0037US0

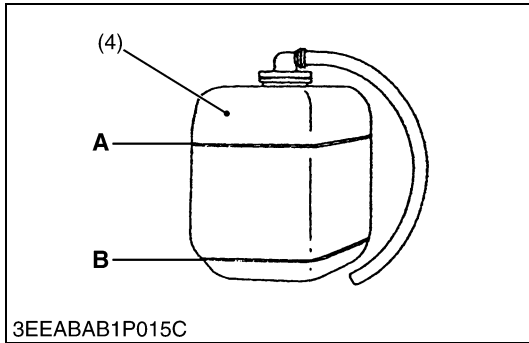
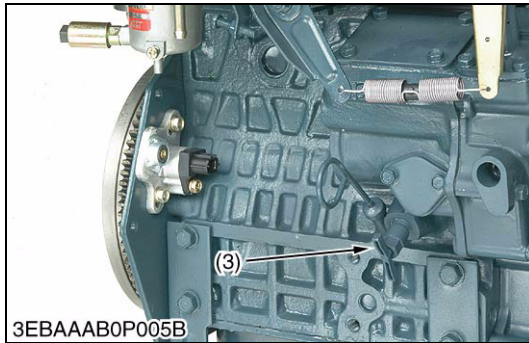
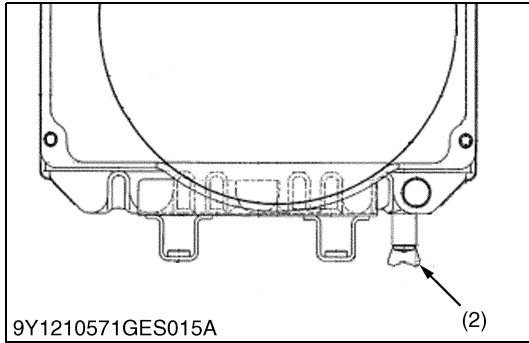
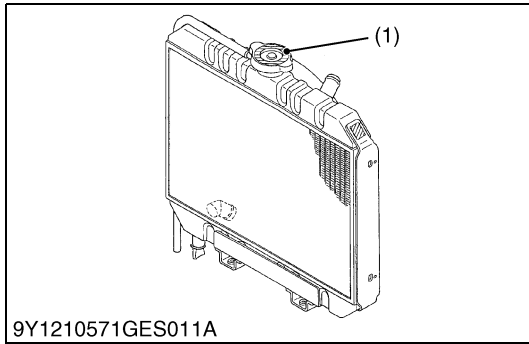

Cleaning Water Jacket and Radiator Interior

⚠ CAUTION

- **Do not remove the radiator cap when the engine is hot. Then loosen cap slightly to the stop to relieve any excess pressure before removing cap completely.**
1. Stop the engine and let cool down.
 2. To drain the coolant, open the radiator drain plug (2) and remove the radiator cap (1). Then radiator cap (1) must be removed to completely drain the coolant. And open the drain cock (3) of engine body.
 3. After all coolant is drained, close the drain plug.
 4. Fill with clean water and cooling system cleaner.
 5. Follow directions of the cleaner instruction.
 6. After flushing, fill with clean water and anti-freeze until the coolant level is just below the port. Install the radiator cap (1) securely.
 7. Fill with coolant up to **FULL "A"** mark on the recovery tank (4).
 8. Start and operate the engine for few minutes.
 9. Stop the engine and let cool. Check coolant level of recovery tank (4) and add coolant if necessary.

■ IMPORTANT

- **Do not start engine without coolant.**
- **Use clean, fresh, soft water and anti-freeze to fill the radiator and recovery tank.**
- **When the anti-freeze is mixed with fresh, soft water, the anti-freeze mixing ratio must be less than 50 %.**
- **Securely tighten radiator cap. If the cap is loose or improperly fitted, water may leak out and the engine could overheat.**

- | | |
|-------------------|-----------------|
| (1) Radiator Cap | A : FULL |
| (2) Drain Plug | B : LOW |
| (3) Drain Cock | |
| (4) Recovery Tank | |

9Y1210571GEG0041US0

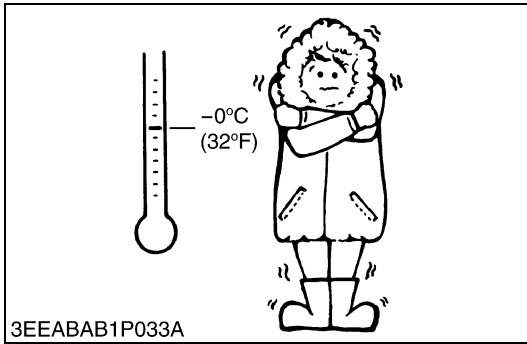

Anti-Freeze

- There are two types of anti-freeze available: use the permanent type (PT) for this engine.
- Before adding anti-freeze for the first time, clean the radiator interior by pouring fresh, soft water and draining it a few times.
- The procedure for mixing water and anti-freeze differs according to the make of the anti-freeze and the ambient temperature. Basically, it should be referred to SAE J1034 standard, more specifically also to SAE J814c.
- Mix the anti-freeze with fresh, soft water, and then fill into the radiator.

■ IMPORTANT

- **When the anti-freeze is mixed with fresh, soft water, the anti-freeze mixing ratio must be less than 50 %.**

Vol % anti-freeze	Freezing point		Boiling point*	
	°C	°F	°C	°F
40	-24	-11	106	223
50	-37	-35	108	226

* At 1.01×100000 Pa (760 mmHg) pressure (atmospheric). A higher boiling point is obtained by using a radiator pressure cap which permits the development of pressure within the cooling system.

■ NOTE

- The above data represents industrial standards that necessitate a minimum glycol content in the concentrated anti-freeze.
- When the coolant level drops due to evaporation, add fresh, soft water only to keep the anti-freeze mixing ratio less than 50 %. In case of leakage, add anti-freeze and fresh, soft water in the specified mixing ratio.
- Anti-freeze absorbs moisture. Keep unused anti-freeze in a tightly sealed container.
- Do not use radiator cleaning agents when anti-freeze has been added to the coolant.
(Anti-freeze contains an anti-corrosive agent, which will react with the radiator cleaning agent forming sludge which will affect the engine parts.)

9Y1210318GEG0041US0

[7] CHECK POINTS OF EVERY 1000 HOURS

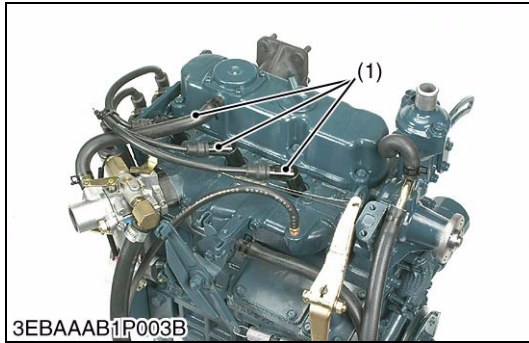

Replacing Spark Plug

1. Disconnect the spark plug cap (1).
2. Remove the spark plug.
3. Replace the new spark plug.
4. Tighten the spark plug with a plug wrench.

■ IMPORTANT

(When reassembling)

- Put the high tension cord cap inside the spark plug terminal firmly.
- Make sure that the cylinder number is corresponding to the high tension cord number.
- Wrong connection causes high temperature on catalytic muffler/converter.

Spark plug	WG752-G/GL-E3	NGK BKR4E-11
	WG972-G/GL-E3	NGK BKR4E

Tightening torque	Spark plug	20 to 24 N·m 2.0 to 2.5 kgf·m 15 to 18 lbf·ft
-------------------	------------	---

(1) Spark Plug Cap

9Y1210571GEG0031US0



Checking Coolant Hose of LPG Vaporizer (WG752-GL-E3, WG972-GL-E3)

1. Check the coolant hoses (1) for damage.
2. If the coolant hose is damaged, replace it.

(1) Coolant Hoses to Vaporizer

9Y1210571GEG0014US0

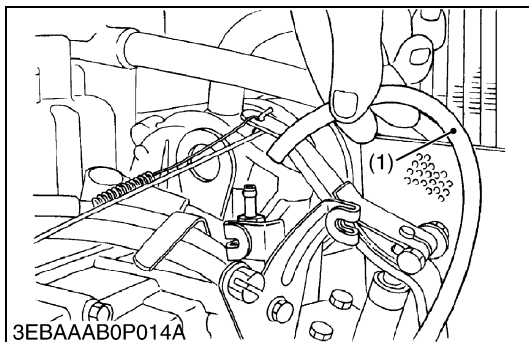

Checking Vacuum Lock Hose of LPG Vaporizer (WG752-GL-E3, WG972-GL-E3)

1. Check the vacuum lock hose (1) for damage.
2. If the hose is damaged, replace it.

(1) Vacuum Lock Hoses

9Y1210571GEG0015US0

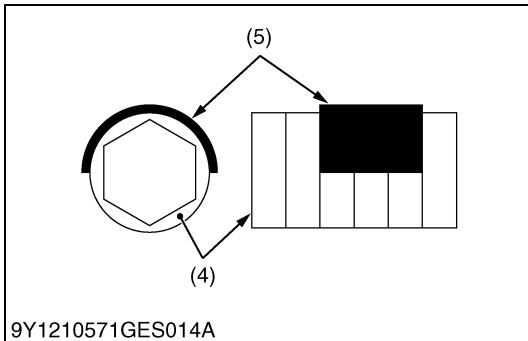
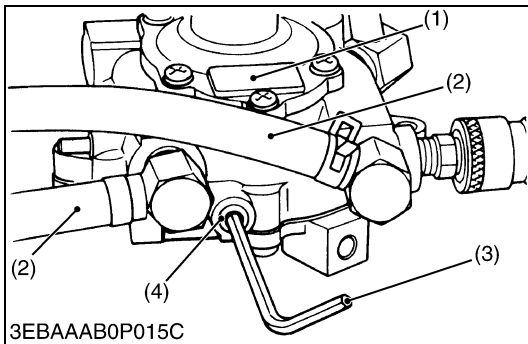

Draining Tar (Vaporizer for WG752-GL-E3, WG972-GL-E3)

1. Run the engine until it is warmed up.
2. The shut off solenoid valve is shut and the engine is stopped naturally.
3. Place an oil pan underneath the drain port.
4. Remove the drain plug (4), and drain tar.
5. Tighten the drain plug (4).

■ NOTE

- Apply a liquid gasket (Three Bond 1104 or equivalent) to the thread of the plug.

- | | |
|------------------|-------------------|
| (1) Vaporizer | (4) Drain Plug |
| (2) Coolant Hose | (5) Liquid Gasket |
| (3) Wrench | |

9Y1210571GEG0016US0

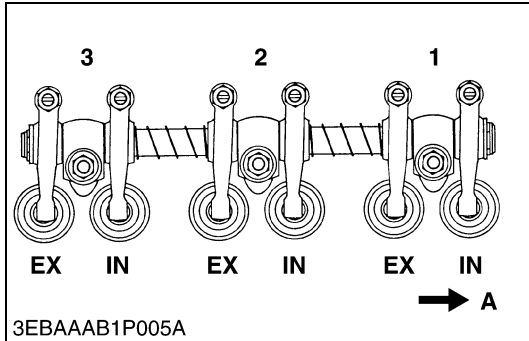
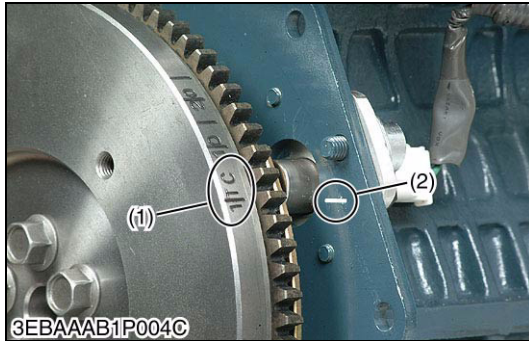
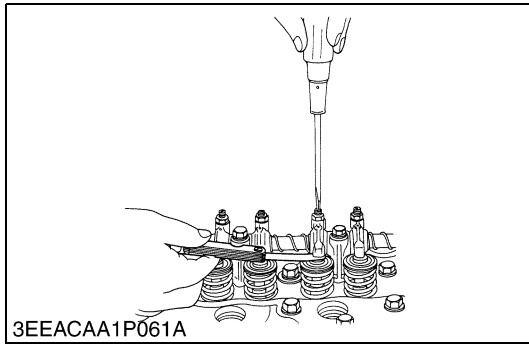

Checking Valve Clearance

■ **IMPORTANT**

- **The valve clearance must be checked and adjusted when engine is cold.**
1. Remove the cylinder head cover and the spark plugs.
 2. Align the "1TC" mark (1) on the flywheel and alignment mark (2) on the rear end plate so that the No. 1 piston comes to the compression top dead center.
 3. Check the following valve clearance marked with "★" using a feeler gauge.
 4. If the clearance is not within the factory specifications, adjust with the adjusting screw.
 5. Then turn the flywheel 6.28 rad (360 °), and align the "1TC" mark (1) on the flywheel and alignment mark (2) on the rear end plate so that the No. 1 piston comes to the overlap position.
 6. Check the following valve clearance marked with "☆" using a feeler gauge.
 7. If the clearance is not within the factory specifications, adjust with the adjusting screw.

Adjustable Cylinder Location of Piston	Valve Arrangement	
	Intake valve	Exhaust valve
No. 1	★	★
No. 2	☆	★
No. 3	★	☆

★ : When No. 1 piston is at the compression top dead center position.
 ☆ : When No. 1 piston is at the overlap position.

Intake and exhaust valve clearance (cold)	Factory specification	0.145 to 0.185 mm 0.00571 to 0.00728 in.
---	-----------------------	---

■ **NOTE**

- **The sequence of cylinder numbers is given as No. 1, No. 2 and No. 3 starting from the gear case side.**
- **After adjusting the valve clearance, secure the adjusting screw with the lock nut.**

- (1) "1TC" Mark
- (2) Alignment Mark

A : Gear Case Side

9Y1210318GEG0046US0

[8] CHECK POINTS OF EVERY AFTER 1000 HOURS



Cleaning Combustion Chamber (if necessary)

1. Remove the breather hose.
2. Remove the head cover screws.
3. Remove the cylinder head cover.
4. Remove the screws of the rocker arm bracket.
5. Remove the rocker arm assembly.
6. Remove the push rods.
7. Remove the cylinder head screw.
8. Lift up the cylinder head to remove.
9. Remove the cylinder head gasket.
10. Clean the carbon of the combustion chamber (piston head and piston side of cylinder head) with wire brush.

(When reassembling)

- When you put the push rods on the tappets, make sure that their ends are correctly engaged with the grooves.
- Make sure that the cylinder head cover gasket is not defective.
- Replace the cylinder head gasket with a new one.
- Replace the exhaust manifold gasket with a new one.
- Replace the muffler gasket with a new one.

■ **IMPORTANT**

- **After you install the rocker arm, adjust the valve clearance.**
- **Put the high tension cord cap inside the spark plug terminal firmly.**
- **Make sure that the cylinder number is corresponding to the high tension cord number.**
- **Wrong connection causes high temperature on catalytic muffler/converter.**

Tightening torque	Cylinder head screw	40 to 44 N·m 4.0 to 4.5 kgf·m 29 to 32 lbf·ft
	Rocker arm bracket screw	12 to 14 N·m 1.2 to 1.5 kgf·m 8.7 to 10 lbf·ft
	Cylinder head cover screw	9.81 to 11.2 N·m 1.00 to 1.15 kgf·m 7.24 to 8.31 lbf·ft

9Y1210571GEG0034US0

[9] CHECK POINTS OF EVERY 2 YEARS

Replacing Intake Air Line

1. Replace the intake hose and the clamps between the air cleaner and the carburetor or gas mixer.

9Y1210318GEG0049US0

Replacing Breather Hose

1. Replace the breather hose and the clamps between the head cover and the air cleaner flange.

(1) Breather Hose

9Y1210571GEG0035US0

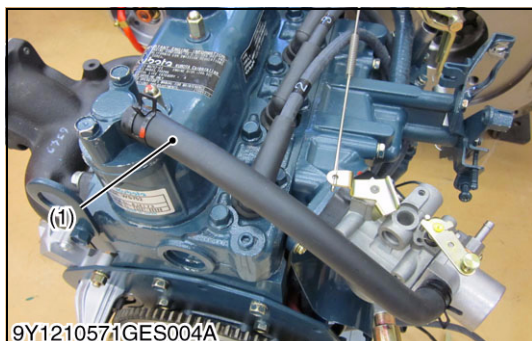

Replacing LPG Fuel Hose and Clamp Bands (WG752-GL-E3, WG972-GL-E3)

1. Replace the fuel hose and the clamps.

9Y1210571GEG0017US0

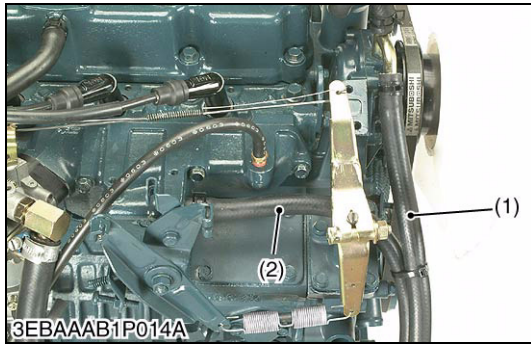

Replacing Coolant Hose of LPG Vaporizer (WG752-GL-E3, WG972-GL-E3)

1. Connect the new coolant hose (1) and (2) to the vaporizer (3).
2. Hold the joint of vaporizer upward.
3. The coolant replenished to radiator, and bleed the air from the vaporizer (3).

- (1) Coolant Hose
- (2) Coolant Hose
- (3) Vaporizer

A : Joint

9Y1210571GEG0018US0

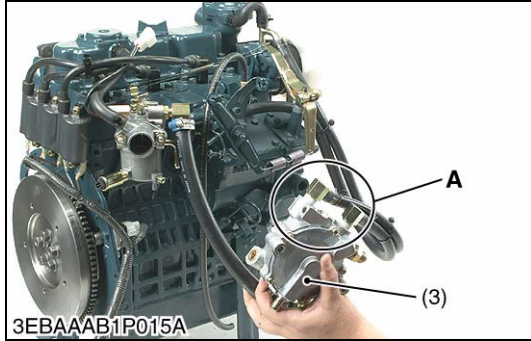

Replacing Vacuum Lock Hose of LPG Vaporizer (WG752-GL-E3, WG972-GL-E3)

1. Connect the new vacuum lock hose (1).

- (1) Vacuum Lock Hose

9Y1210571GEG0019US0



Checking Primary Chamber (WG752-GL-E3, WG972-GL-E3)

■ IMPORTANT

- When checking the fuel system after completely consuming the fuel in piping.
- Treat a seal tape or liquid gasket when install each connector.

1. Run the engine until is warmed up.
2. Shut a shut off solenoid valve and the engine stopped naturally.
3. Disconnect the plug (1).
4. Set the pressure gauge (2).
5. Open a shut off solenoid valve and the engine is started.
6. Check the pressure.
7. If the pressure is not within the factory specification, replace the vaporizer.

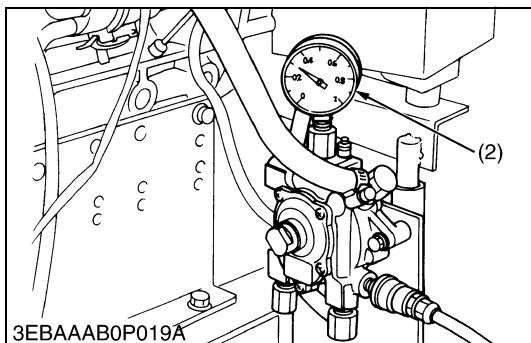
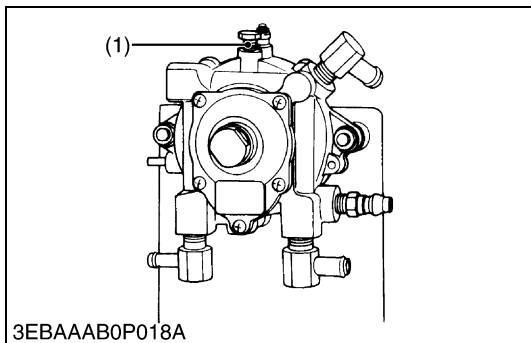

Pressure	Factory specification	30 to 34 kPa 0.30 to 0.35 kgf/cm ² 4.3 to 4.9 psi
----------	-----------------------	--

(1) Plug

(2) Pressure Gauge

9Y1210571GEG0020US0

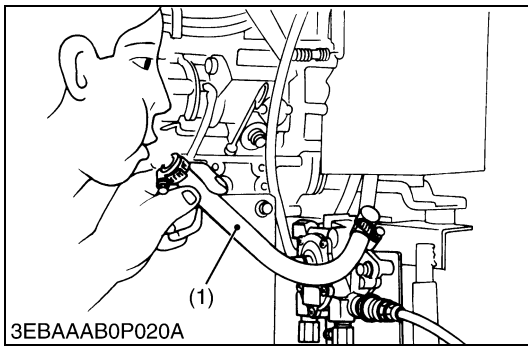

Checking Air Tight of Secondary Chamber (WG752-GL-E3, WG972-GL-E3)

1. Disconnect the vapor hose (1) from the mixer side.
2. Blow a breath lightly or compressed air (9.8 kPa, 0.10 kgf/cm², 1.4 psi).
3. Make sure that there is no air leak.
4. If there is a leakage, replace the vaporizer.

(1) Vapor Hose

9Y1210571GEG0021US0



Checking Vacuum Lock System (WG752-GL-E3, WG972-GL-E3)

1. After warming up, and set the low idling speed.
2. Disconnect the vacuum lock hose (1), and close the joint manifold by finger.
3. Make sure that the engine stops.

(1) Vacuum Lock Hose

(2) Joint

9Y1210571GEG0022US0

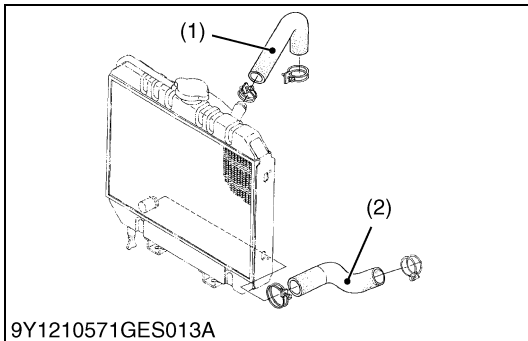

Replacing Radiator Hoses and Clamp Bands

⚠ CAUTION

- Do not remove the radiator cap when the engine is hot. Then loosen cap slightly to the stop to relieve any excess pressure before removing cap completely.

1. Drain the coolant.
2. Loosen the clamp bands.
3. Remove the upper hose (1) and lower hose (2).
4. Replace new upper / lower hose (1), (2) and clamp bands.
5. Tighten the clamp bands.
6. Fill with clean water and anti-freeze until the coolant level is just below the port. Install the radiator cap securely.

(1) Upper Hose

(2) Lower Hose

9Y1210571GEG0042US0

Replacing Battery

⚠ CAUTION

- When the battery is being activated, hydrogen and oxygen gases in the battery are extremely explosive. Keep open sparks and flames away from the battery at all times, especially when charging the battery.
- When charging battery, remove battery vent plugs.
- When disconnecting the cable from the battery, start with the negative terminal first. When connecting the cable to the battery, start with the positive terminal first.
- Never check battery charge by placing a metal object across the posts.

1. Disconnect the negative terminal and positive terminal.
2. Remove the battery holder.
3. Remove the used battery.
4. Replace the new battery.
5. Tighten the battery holder.
6. Connect the positive terminal.
7. Connect the negative terminal.

9Y1210318GEG0058US0

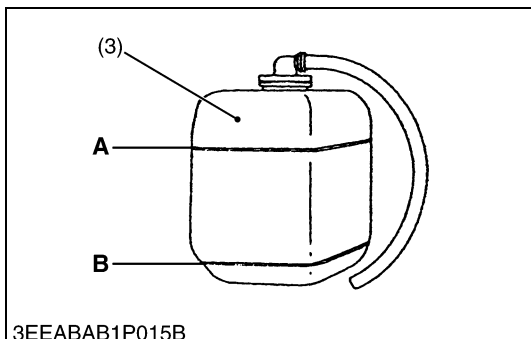
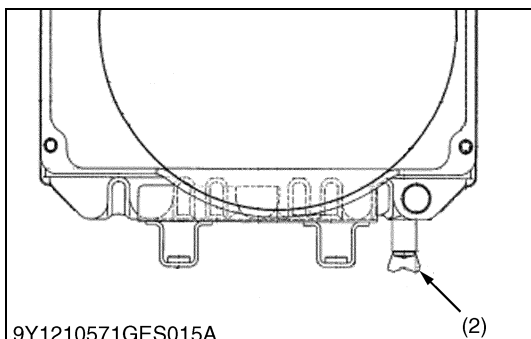
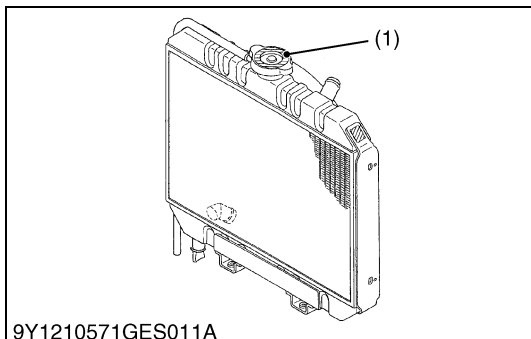
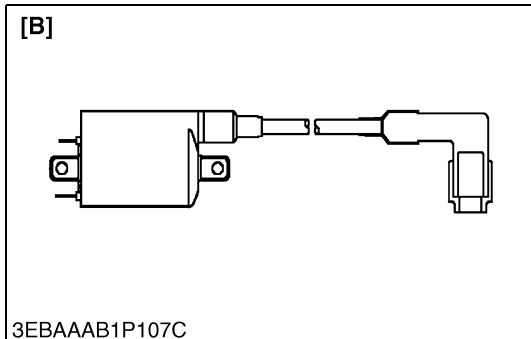
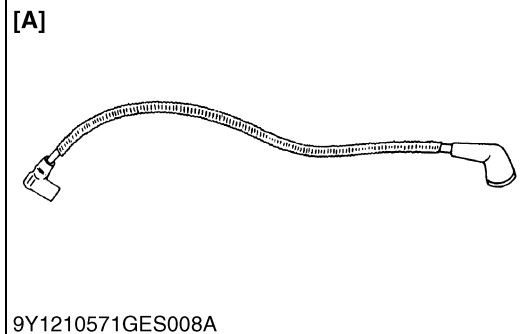

Replacing Ignition Wires

1. Replace high tension code.

IMPORTANT
(When reassembling)

- Put the high tension cord cap inside the spark plug terminal firmly.
- Make sure that the cylinder number is corresponding to the high tension cord number and the distributor terminal number. (WG752-G/GL-E3)
- Make sure that the cylinder number is corresponding to the high tension cord number. (WG972-G/GL-E3)
- Wrong connection causes high temperature on catalytic muffler/convertor.

[A] WG752-G/GL-E3
[B] WG972-G/GL-E3

9Y1210571GEG0036US0

Changing Radiator Coolant (L.L.C.)

CAUTION

- Do not remove the radiator cap when the engine is hot. Then loosen cap slightly to the stop to relieve any excess pressure before removing cap completely.

1. Stop the engine and let cool down.
2. To drain the coolant, open the radiator drain plug (2) and remove the radiator cap (1). Then radiator (1) must be removed to completely drain the coolant. And open the drain cock of engine body.
3. After all coolant is drained, close the drain plug (2).
4. Fill with clean water and cooling system cleaner.
5. Follow directions of the cleaner instruction.
6. After flushing, fill with clean water and anti-freeze until the coolant level is just below the port. Install the radiator cap (1) securely.
7. Fill with coolant up to **FULL "A"** mark on the recovery tank (3).
8. Start and operate the engine for few minutes.
9. Stop the engine and let cool. Check coolant level of radiator and recovery tank (3) and add coolant if necessary.

IMPORTANT

- Do not start engine without coolant.
- Use clean, fresh, soft water and anti-freeze to fill the radiator and recovery tank.
- When the anti-freeze is mixed with fresh, soft water, the anti-freeze mixing ratio must be less than 50 %.
- Securely tighten radiator cap. If the cap is loose or improperly fitted, water may leak out and the engine could overheat.

(1) Radiator Cap	A : Full
(2) Drain Plug	B : Low
(3) Recovery Tank	

(To be continued)

(Continued)

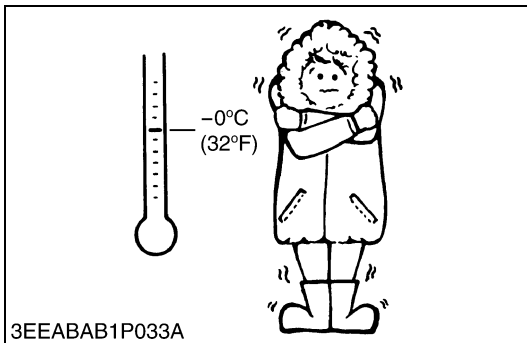
**(Anti-freeze)**

- There are two types of anti-freeze available; use the permanent type (PT) for this engine.
- Before adding anti-freeze for the first time, clean the radiator interior by pouring fresh, soft water and drain it a few times.
- The procedure for mixing water and anti-freeze differs according to the make of the anti-freeze and the ambient temperature. Basically, it should be referred to SAE J1034 standard, more specifically also to SAE J814c.
- Mix the anti-freeze with fresh, soft water, and then fill into the radiator.

■ IMPORTANT

- **When the anti-freeze is mixed with fresh, soft water, and anti-freeze mixing ratio must be less than 50 %.**

Vol % anti-freeze	Freezing point		Boiling point*	
	°C	°F	°C	°F
40	-24	-11	106	223
50	-37	-35	108	226

* At 1.01 x 100000 Pa (760 mmHg) pressure (atmospheric). A higher boiling point is obtained by using a radiator pressure cap which permits the development of pressure within the cooling system.

■ NOTE

- The above data represents industrial standards that necessitate a minimum glycol content in the concentrated anti-freeze.
- When the coolant level drops due to evaporation, add fresh, soft water only to keep the anti-freeze mixing ratio less than 50 %. In case of leakage, add anti-freeze and fresh, soft water in the specified mixing ratio.
- Anti-freeze absorbs moisture. Keep unused anti-freeze in a tightly sealed container.
- Do not use radiator cleaning agents when anti-freeze has been added to the coolant.
(Anti-freeze contains an anti-corrosive agent, which will react with the radiator cleaning agent forming sludge which will affect the engine parts.)

9Y1210571GEG0043US0

5. SPECIAL TOOLS

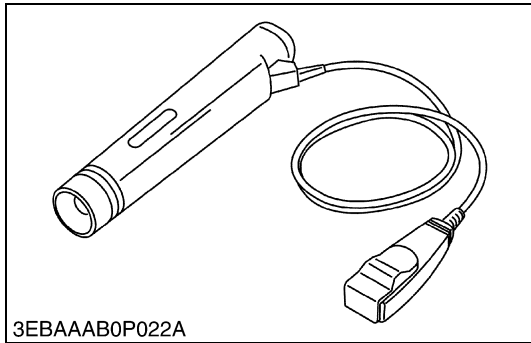

3EBAAAB0P022A

Timing Light

Application

- Use to adjust the ignition timing.

WSM000001GEG0089US0

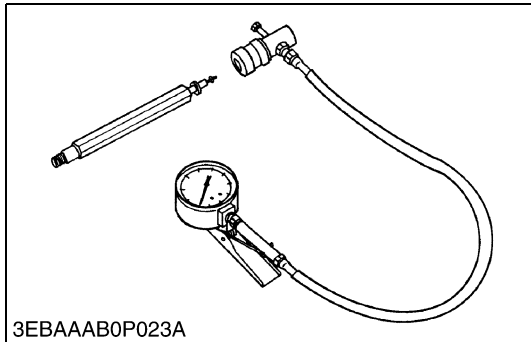

3EBAAAB0P023A

Compression Tester

Code No.

- 07909-30251

Application

- Use to measure gasoline engine compression and diagnose the engine for a major overhaul.

WSM000001GEG0088US0

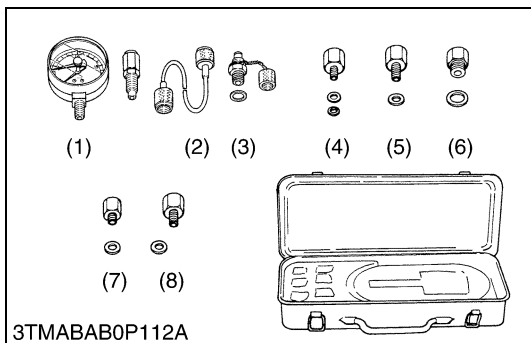

3TMABAB0P112A

Oil Pressure Tester

Code No.

- 07916-32032

Application

- Use to measure lubricating oil pressure.

- | | |
|--------------------|---------------|
| (1) Gauge | (5) Adaptor 2 |
| (2) Cable | (6) Adaptor 3 |
| (3) Threaded Joint | (7) Adaptor 4 |
| (4) Adaptor 1 | (8) Adaptor 5 |

WSM000001GEG0015US0

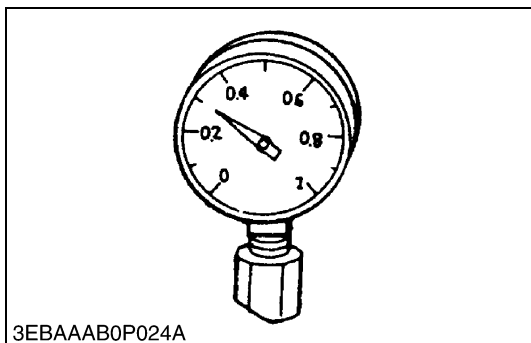

3EBAAAB0P024A

Pressure Gauge

Specification

- 98 kPa (1.0 kgf/cm², 14 psi)

Application

- Check the pressure of vaporizer.

WSM000001GEG0090US0

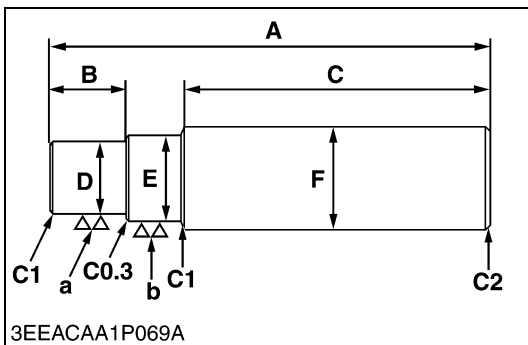
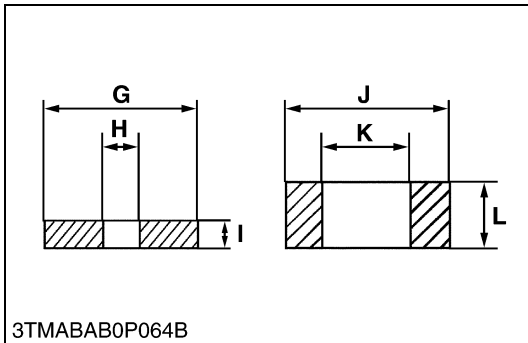
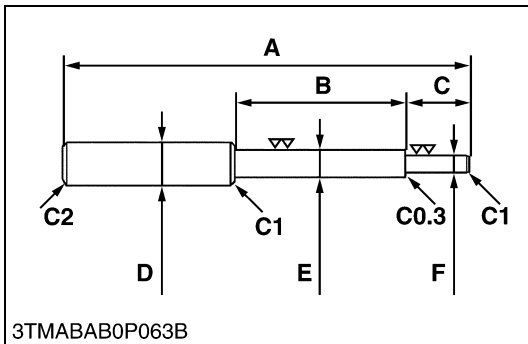

Valve Guide Replacing Tool

Application

- Use to press out and press fit the valve guide.

A	200 mm (7.87 in.)
B	80 mm (3.1 in.)
C	40 mm (1.6 in.)
D	20 mm dia. (0.79 in. dia.)
E	9.960 to 9.980 mm dia. (0.3922 to 0.3929 in. dia.)
F	5.50 to 5.70 mm dia. (0.217 to 0.224 in. dia.)
G	15 mm (0.59 in.)
H	6.00 to 6.10 mm dia. (0.237 to 0.240 in. dia.)
I	5 mm (0.2 in.)
J	18 mm dia. (0.71 in. dia.)
K	10.6 to 10.7 mm dia. (0.418 to 0.421 in. dia.)
L	7 mm (0.3 in.)
C1	Chamfer 1.0 mm (0.039 in.)
C2	Chamfer 2.0 mm (0.079 in.)
C0.3	Chamfer 0.3 mm (0.01 in.)

9Y1210318GEG0060US0

Bushing Replacing Tool

Application

- Use to press out and to press fit the bushing.

[For small end bushing]

Model	WG752-G/GL-E3	WG972-G/GL-E3
A	145 mm (5.71 in.)	145 mm (5.71 in.)
B	20 mm (0.79 in.)	20 mm (0.79 in.)
C	100 mm (3.94 in.)	100 mm (3.94 in.)
D	17.90 to 17.95 mm dia. (0.7048 to 0.7066 in. dia.)	19.90 to 19.95 mm dia. (0.7835 to 0.7854 in. dia.)
E	19.90 to 19.95 mm dia. (0.7835 to 0.7854 in. dia.)	21.90 to 21.95 mm dia. (0.8622 to 0.8641 in. dia.)
F	25 mm dia. (0.98 in. dia.)	25 mm dia. (0.98 in. dia.)
a	6.3 μm (250 μin.)	6.3 μm (250 μin.)
b	6.3 μm (250 μin.)	6.3 μm (250 μin.)

[For idle gear bushing]

A	150 mm (5.91 in.)
B	20 mm (0.79 in.)
C	100 mm (3.94 in.)
D	19.90 to 19.95 mm dia. (0.7835 to 0.7854 in. dia.)
E	21.90 to 21.95 mm dia. (0.8622 to 0.8641 in. dia.)
F	25 mm dia. (0.98 in. dia.)
a	6.3 μm (250 μin.)
b	6.3 μm (250 μin.)

9Y1210571GEG0023US0

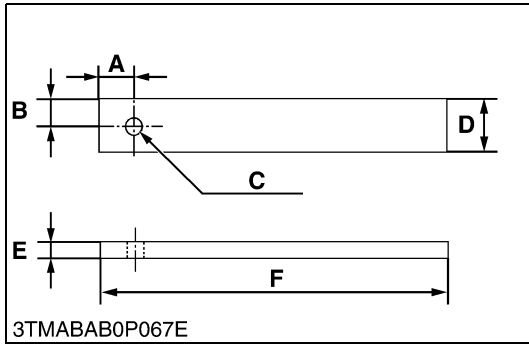

Flywheel Stopper

Application

- Use to loosen and tighten the flywheel screw.

A	20 mm (0.79 in.)
B	15 mm (0.59 in.)
C	10 mm dia. (0.39 in. dia.)
D	30 mm (1.2 in.)
E	8 mm (0.3 in.)
F	200 mm (7.87 in.)

9Y1210318GEG0062US0

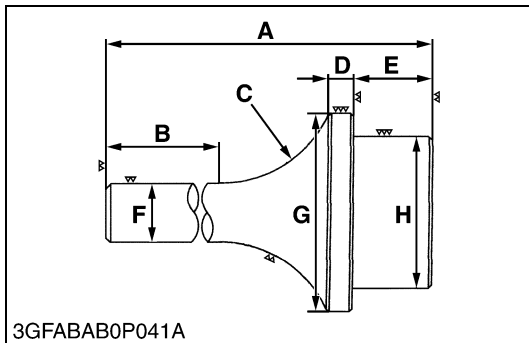

Crankshaft Bearing 1 Replacing Tool

Application

- Use to press out and press fit the crankshaft bearing 1.

[Press Out and Press Fit] (WG752-G/GL-E3)

A	130 mm (5.12 in.)
B	65 mm (2.6 in.)
C	40 mm radius (1.6 in. radius)
D	10 mm (0.39 in.)
E	22 mm (0.87 in.)
F	20 mm dia. (0.79 in. dia.)
G	43.90 to 43.95 mm dia. (1.729 to 1.730 in. dia.)
H	39.90 to 39.95 mm dia. (1.571 to 1.572 in. dia.)

[Press Out] (WG972-G/GL-E3)

A	135 mm (5.31 in.)
B	72 mm (2.8 in.)
C	40 mm radius (1.6 in. radius)
D	10 mm (0.39 in.)
E	22 mm (0.87 in.)
F	20 mm dia. (0.79 in. dia.)
G	47.90 to 47.95 mm dia. (1.886 to 1.887 in. dia.)
H	43.90 to 43.95 mm dia. (1.729 to 1.730 in. dia.)

[Press Fit] (WG972-G/GL-E3)

A	130 mm (5.12 in.)
B	72 mm (2.8 in.)
C	40 mm radius (1.6 in. radius)
D	9 mm (0.4 in.)
E	24 mm (0.94 in.)
F	20 mm (0.79 in.)
G	68 mm dia. (2.7 in. dia.)
H	43.90 to 43.95 mm dia. (1.729 to 1.730 in. dia.)

9Y1210571GEG0025US0

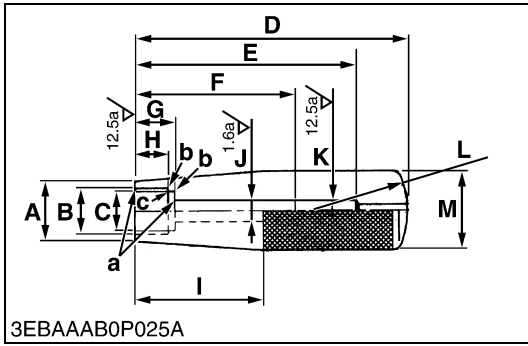

Valve Stem Seal Replacing Tool

Application

- Use to press fit the valve stem seal.

A	17.5 mm dia. (0.689 in. dia.)
B	13.7 to 13.9 mm dia. (0.540 to 0.547 in. dia.)
C	11.0 to 11.2 mm dia. (0.433 to 0.440 in. dia.)
D	75 mm (3.0 in.)
E	60 mm (2.4 in.)
F	45 mm (1.8 in.)
G	11.5 to 11.6 mm (0.453 to 0.456 in.)
H	8.5 mm (0.33 in.)
I	37.5 mm (1.48 in.)
J	6 mm dia. (0.2 in. dia.)
K	6 mm dia. (0.2 in. dia.)
L	R 30
M	26 mm dia. (1.0 in. dia.)
a	Chamfer 0.3 mm (0.01 in.)
b	Chamfer 0.4 mm (0.02 in.)
c	Chamfer 0.2 mm (0.008 in.)

9Y1210318GEG0064US0

1 ENGINE

MECHANISM

CONTENTS

1. ENGINE BODY	1-M1
[1] CYLINDER BLOCK	1-M1
[2] HALF-FLOATING HEAD COVER (WG972-G/GL-E3)	1-M1
[3] CYLINDER HEAD	1-M2
[4] CRANKSHAFT	1-M2
[5] PISTON AND PISTON RING	1-M3
[6] OIL PAN	1-M4
[7] CONNECTING ROD	1-M4
[8] CAMSHAFT	1-M4
[9] DISTRIBUTOR SHAFT (WG752-G/GL-E3)	1-M5
[10] GEAR SHAFT (WG972-G/GL-E3)	1-M5
[11] ROCKER ARM ASSEMBLY	1-M5
[12] INLET AND EXHAUST VALVES	1-M6
[13] FLYWHEEL	1-M6
[14] CLOSED BREATHER	1-M6
2. LUBRICATING SYSTEM	1-M7
[1] GENERAL	1-M7
[2] OIL PUMP	1-M8
[3] RELIEF VALVE	1-M8
[4] OIL FILTER CARTRIDGE	1-M8
[5] OIL PRESSURE SWITCH	1-M9
3. COOLING SYSTEM	1-M10
[1] GENERAL	1-M10
[2] COOLING FIN (WG972-G/GL-E3)	1-M10
[3] WATER PUMP	1-M10
[4] THERMOSTAT	1-M11
[5] RADIATOR	1-M11
[6] RADIATOR CAP	1-M12
[7] VAPORIZER (WG752-GL-E3, WG972-GL-E3)	1-M12
4. FUEL SYSTEM	1-M13
[1] GENERAL	1-M13
(1) WG752-G/GL-E3, WG972-G/GL-E3	1-M13
[2] CARBURETOR AND DUAL FUEL CARBURETOR	1-M14
(1) Carburetor (WG752-G-E3, WG972-G-E3)	1-M14
(2) Dual Fuel Carburetor (WG752-GL-E3, WG972-GL-E3)	1-M15
[3] VAPORIZER (WG752-GL-E3, WG972-GL-E3)	1-M16
[4] GOVERNOR	1-M19
[5] INLET MANIFOLD	1-M19
[6] FUEL FILTER (FOR GASOLINE LINE)	1-M20
[7] ELECTRO MAGNETIC FUEL FEED PUMP (FOR GASOLINE LINE)	1-M20
5. EXHAUST SYSTEM	1-M21
[1] CATALYST	1-M21
6. IGNITION SYSTEM	1-M22
[1] DISTRIBUTOR (WG752-G/GL-E3)	1-M22
[2] DIGITAL IGNITION SYSTEM (WG972-G/GL-E3)	1-M25
7. ELECTRICAL SYSTEM	1-M26
[1] STARTING SYSTEM	1-M26
[2] CHARGING SYSTEM	1-M27

(1) WG752-G/GL-E3	1-M27
(2) WG972-G/GL-E3	1-M30
[3] SOLENOID	1-M32

1. ENGINE BODY

[1] CYLINDER BLOCK

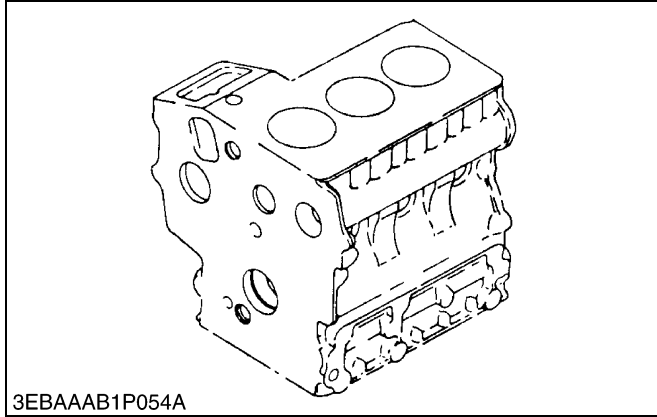

The engine has a high durability tunnel-type cylinder block in which the crank bearing component is a constructed body. Furthermore, liner less type, allow effective cooling, less distortion, and greater wear resistance. The noise level is reduced to a minimum because each cylinder has its own chamber.

To increase the rigidity of the cylinder block, parts of engine block which support main bearing case has thicker rib for additional rigidness to improve noise and vibration.

9Y1210318ENM0001US0

[2] HALF-FLOATING HEAD COVER (WG972-G/GL-E3)

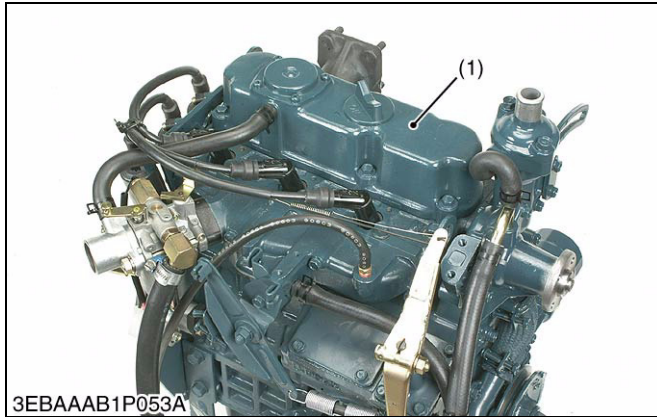

The rubber packing is fitting in to maintain the head cover 0.5 mm (0.02 in.) or so off the cylinder head. This arrangement helps reduce noise coming from the cylinder head.

- (1) Cylinder Head Cover
- (2) Rubber Packing

9Y1210571ENM0005US0

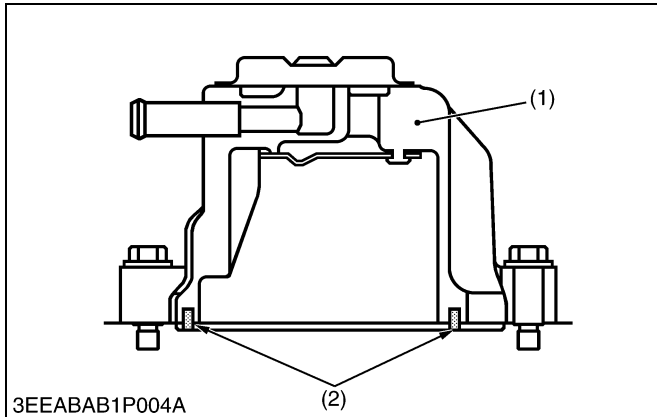

[3] CYLINDER HEAD

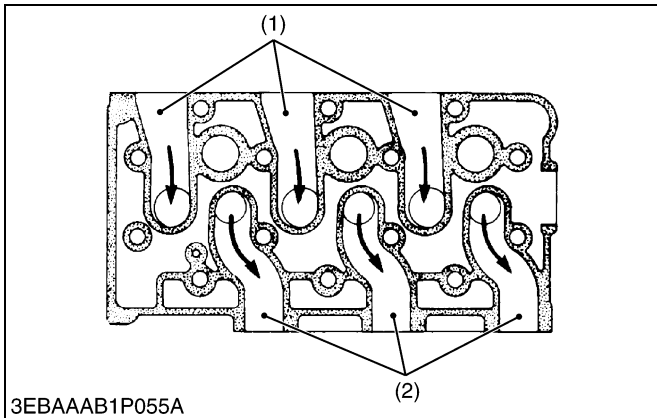

3EBAAAB1P055A

Intake and Exhaust Port

The cross-flow type intake / exhaust ports, which lower the heat conduction from the exhaust port to the intake port. The low heat conduction keeps the intake air from being heated and expanded by the exhaust gas.

- (1) Intake Port
- (2) Exhaust Port

9Y1210318ENM0003US0

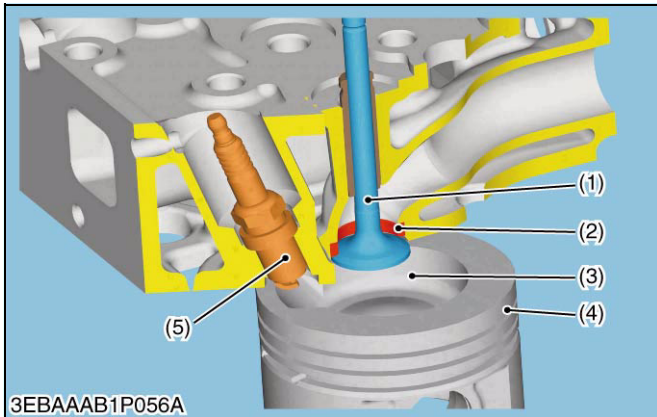

3EBAAAB1P056A

Combustion System

The Spark Ignition type combustion chamber, compactly placed on top of the piston head, successfully reduces emissions. To ensure even more reliable emission life, the intake / exhaust valve seats are fitted with special heat resistant stellite alloys.

- (1) Valve
- (2) Valve Seat
- (3) Main Combustion Chamber
- (4) Piston
- (5) Spark Plug

9Y1210318ENM0004US0

[4] CRANKSHAFT

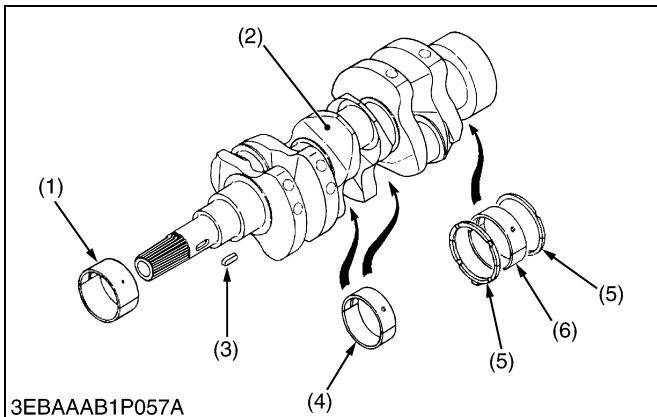

3EBAAAB1P057A

The crankshaft with the connecting rod converts the reciprocating motion of the piston into rotating motion. The crankshaft (2) has oil passages drilled so that oil can flow from the main bearings to the crank pin bearings.

The front journal is supported by a sleeve type bearing (crankshaft bearing 1) (1), the intermediate journal by a split type (crankshaft bearing 3) (4), and the rear by a split type (crankshaft bearing 2) (6) with thrust bearings (5).

- (1) Crankshaft Bearing 1
- (2) Crankshaft
- (3) Feather Key
- (4) Crankshaft Bearing 3
- (5) Thrust Bearing
- (6) Crankshaft Bearing 2

9Y1210318ENM0005US0

[5] PISTON AND PISTON RING

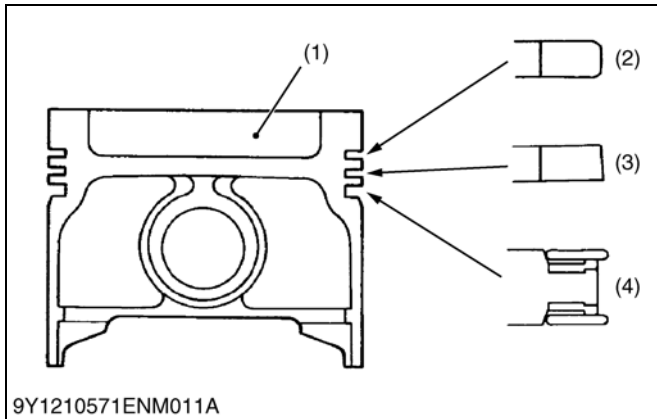

Piston and Piston Ring (WG752-G/GL-E3)

The piston has a slightly oval shape when cold (in consideration of thermal expansion) and a concave head.

Top Ring:

The top ring is of plain barrel face type. The barrel face type has an arc sliding surface easy to run in and prevents abnormal wears by providing a maintained oil film against the lined wall.

Second Ring:

For the second ring, the tapered outer surface area that comes in contact with the lined wall is reduced to obtain a high surface pressure for the prevention of gas leakage, compression leakage and oil spillage.

Oil Ring:

The oil ring has a combined ring that is excellent in oil scrape performance.

- | | |
|------------------------|-----------------|
| (1) Combustion Chamber | (3) Second Ring |
| (2) Top Ring | (4) Oil Ring |

9Y1210571ENM0030US0

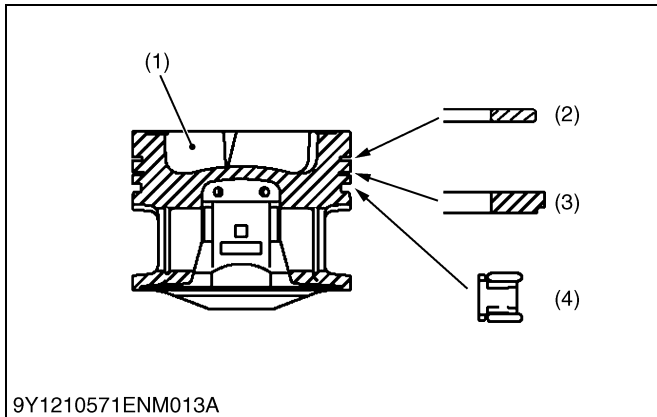

Piston and Piston Ring (WG972-G/GL-E3)

The piston head has the combustion chamber (1) with the concave of bathtub shaped type.

Top Ring:

Barrel-faced type has an ideal shape in terms of lubrication theory in order to prevent abnormal wear due to edge loading at the time of initial running-in, and it is very effective in prevention of blow-by.

Second Ring:

In this type, undercut machining is interrupted at both ends of the joint. It has an oil scraping property which is inherent to the scraper type as well as control action against blow-by which is caused by undercutting.

Oil Ring:

Oil ring consists of three steel components, that is upper and lower rails and one spacer being held between two rails. This function is particularly effective in preventing oil-up because of high boost at the time of engine coasting.

- | | |
|------------------------|-----------------|
| (1) Combustion Chamber | (3) Second Ring |
| (2) Top Ring | (4) Oil Ring |

9Y1210571ENM0031US0

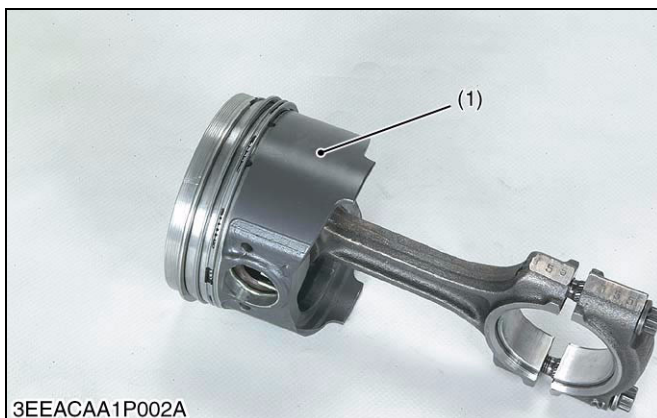

Piston Skirt (WG972-G/GL-E3)

Piston's skirt is coated with **molybdenum disulfide**★, which reduces the piston slap noise and thus the entire operating noise.

★ Molybdenum disulfide (MoS₂)

The molybdenum disulfide serves as a solid lubricant, like a Graphite or Teflon. This material helps resist metal wears even with little lube oil.

- (1) Molybdenum Disulfide

9Y1210318ENM0007US0

[6] OIL PAN

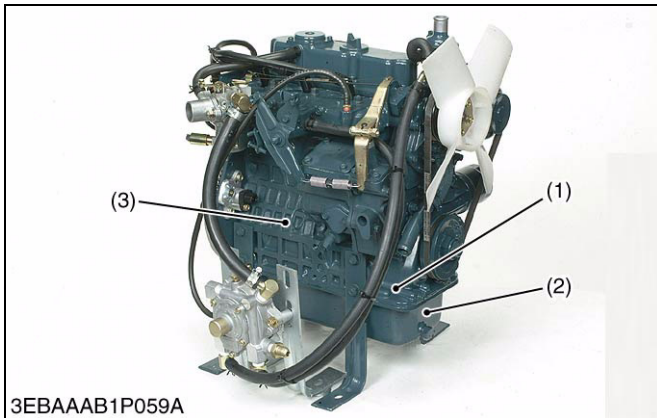

The oil pan is expanded under the gear case. Therefore, the height of the engine can be lowered more than so far while securing a necessary amount of oil.

- (1) Gear Case
- (2) Oil Pan
- (3) Crank Case

9Y1210318ENM0008US0

[7] CONNECTING ROD

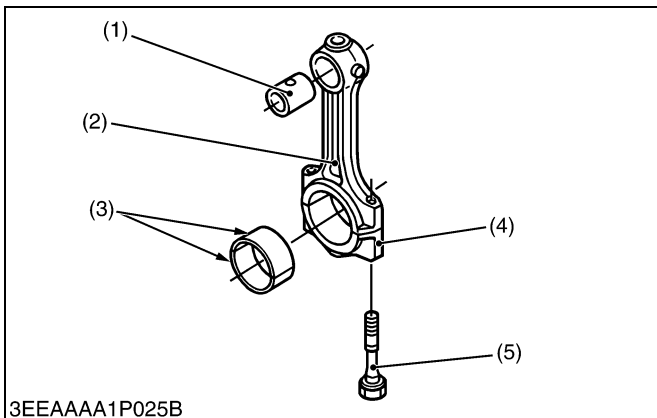

The connecting rod (2) is used to connect the piston with the crankshaft. The big end of the connecting rod has a crankpin bearing (3) (split type) and the small end has a small end bushing (1) (solid type).

- (1) Small End Bushing
- (2) Connecting Rod
- (3) Crankpin Bearing
- (4) Connecting Rod Cap
- (5) Connecting Rod Screw

9Y1210318ENM0009US0

[8] CAMSHAFT

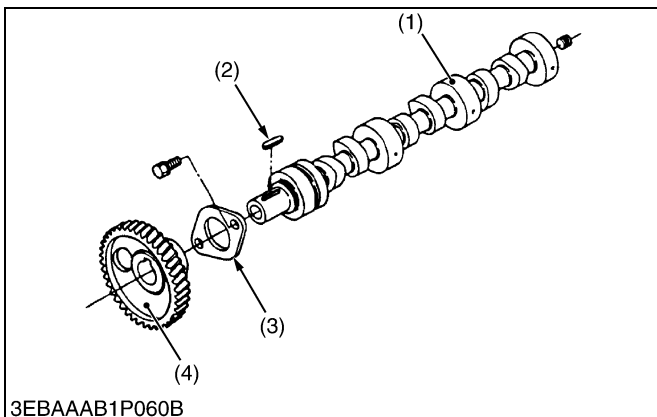

The camshaft (1) is made of special cast iron, and the journal and cam sections are chilled to resist wear.

The cams on the camshaft cause the intake and exhaust valves to open as the camshaft rotates. The bearing and journals are force-lubricated.

- (1) Camshaft
- (2) Feather Key
- (3) Camshaft Stopper
- (4) Cam Gear

9Y1210318ENM0010US0

[9] DISTRIBUTOR SHAFT (WG752-G/GL-E3)

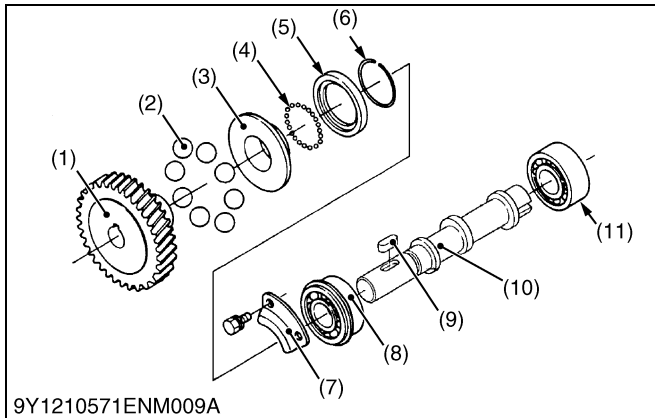

9Y1210571ENM009A

The distributor shaft (10) controls the ignition timing of distributor and is equipped with steel ball (2) to control the governor.

- | | |
|-------------------------------|------------------------|
| (1) Injection Pump Gear | (7) Stopper |
| (2) Steel Ball | (8) Ball Bearing |
| (3) Governor Sleeve | (9) Feather key |
| (4) Steel Ball | (10) Distributor shaft |
| (5) Governor Ball Case | (11) Ball Bearing |
| (6) Governor Sleeve Snap Ring | |

9Y1210571ENM0016US0

[10] GEAR SHAFT (WG972-G/GL-E3)

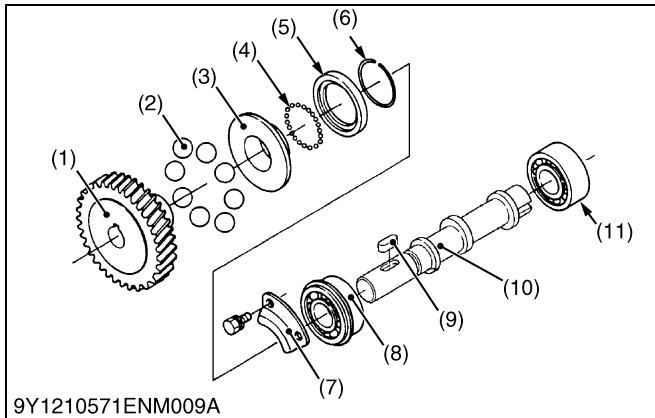

9Y1210571ENM009A

The gear shaft (10) is equipped with steel ball (2) to control the governor.

- | | |
|-------------------------------|-------------------|
| (1) Injection Pump Gear | (7) Stopper |
| (2) Steel Ball | (8) Ball Bearing |
| (3) Governor Sleeve | (9) Feather key |
| (4) Steel Ball | (10) Gear shaft |
| (5) Governor Ball Case | (11) Ball Bearing |
| (6) Governor Sleeve Snap Ring | |

9Y1210571ENM0021US0

[11] ROCKER ARM ASSEMBLY

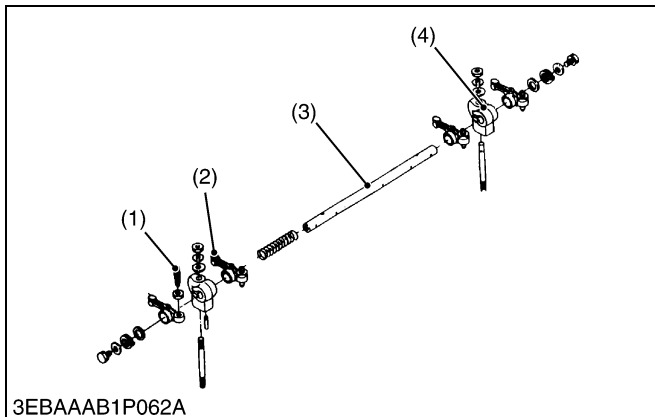

3EBAAAB1P062A

The rocker arm assembly includes the rocker arms (2) and adjusting screws (1), the end of which rests on the push rods, rocker arm brackets (4) and rocker arm shaft (3).

The rocker arms swing and transmits the reciprocating motion of the push rods to the inlet and exhaust valves to open and close them.

- | | |
|---------------------|------------------------|
| (1) Adjusting Screw | (3) Rocker Arm Shaft |
| (2) Rocker Arm | (4) Rocker Arm Bracket |

9Y1210318ENM0012US0

[12] INLET AND EXHAUST VALVES

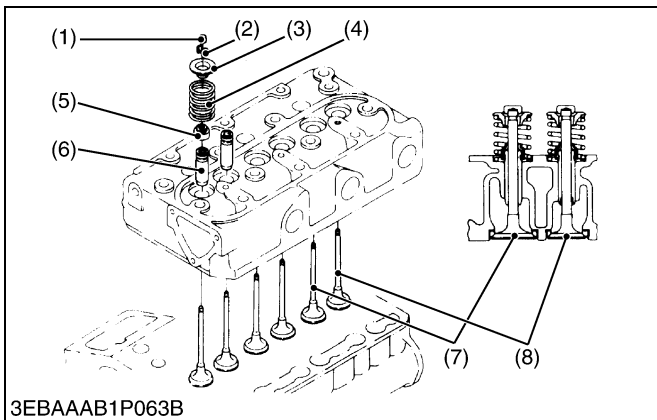

The valve and its guide for the inlet are different from those for the exhaust.

Other parts, such as the spring (4), spring retainer (3), collet (2), stem seal (5), and cap (1) are the same for both the inlet and exhaust.

- | | |
|---------------------|-------------------|
| (1) Valve Cap | (5) Stem Seal |
| (2) Collet | (6) Valve Guide |
| (3) Spring Retainer | (7) Inlet Valve |
| (4) Spring | (8) Exhaust Valve |

9Y1210318ENM0013US0

[13] FLYWHEEL

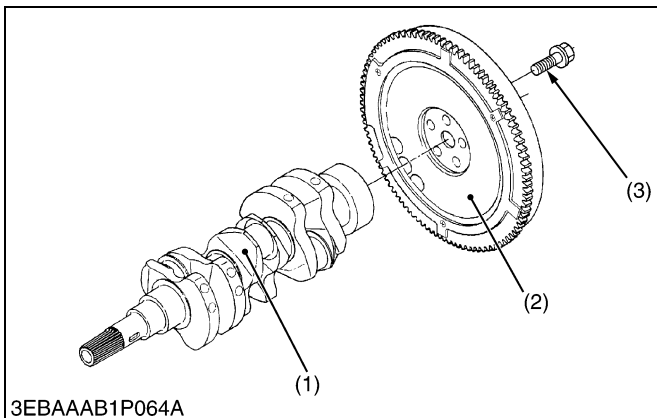

The flywheel (2) is connected with the crankshaft (1), it stores the rotating force in the combustion stroke as inertial energy to rotate the crankshaft smoothly.

The flywheel periphery is provided with marks showing fuel injection timing and top dead center.

The flywheel has gear teeth around its outer rim, which mesh with the drive pinion of the starter.

- | | |
|----------------|-----------------------------|
| (1) Crankshaft | (3) Flywheel Mounting Screw |
| (2) Flywheel | |

9Y1210318ENM0014US0

[14] CLOSED BREATHER

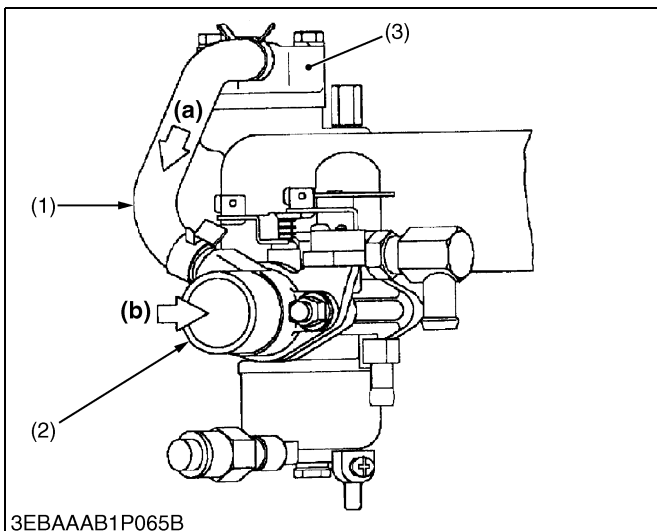

Blow-by gas (a) from crankcase is deoiled in the breather assembly (3) and sends to the air cleaner flange (2) where the blow-by gas (a) is mixed with the intake air (b).

- | | |
|------------------------|-----------------|
| (1) Breather Hose | (a) Blow-by Gas |
| (2) Air Cleaner Flange | (b) Intake Air |
| (3) Breather Assembly | |

9Y1210318ENM0015US0

2. LUBRICATING SYSTEM

[1] GENERAL

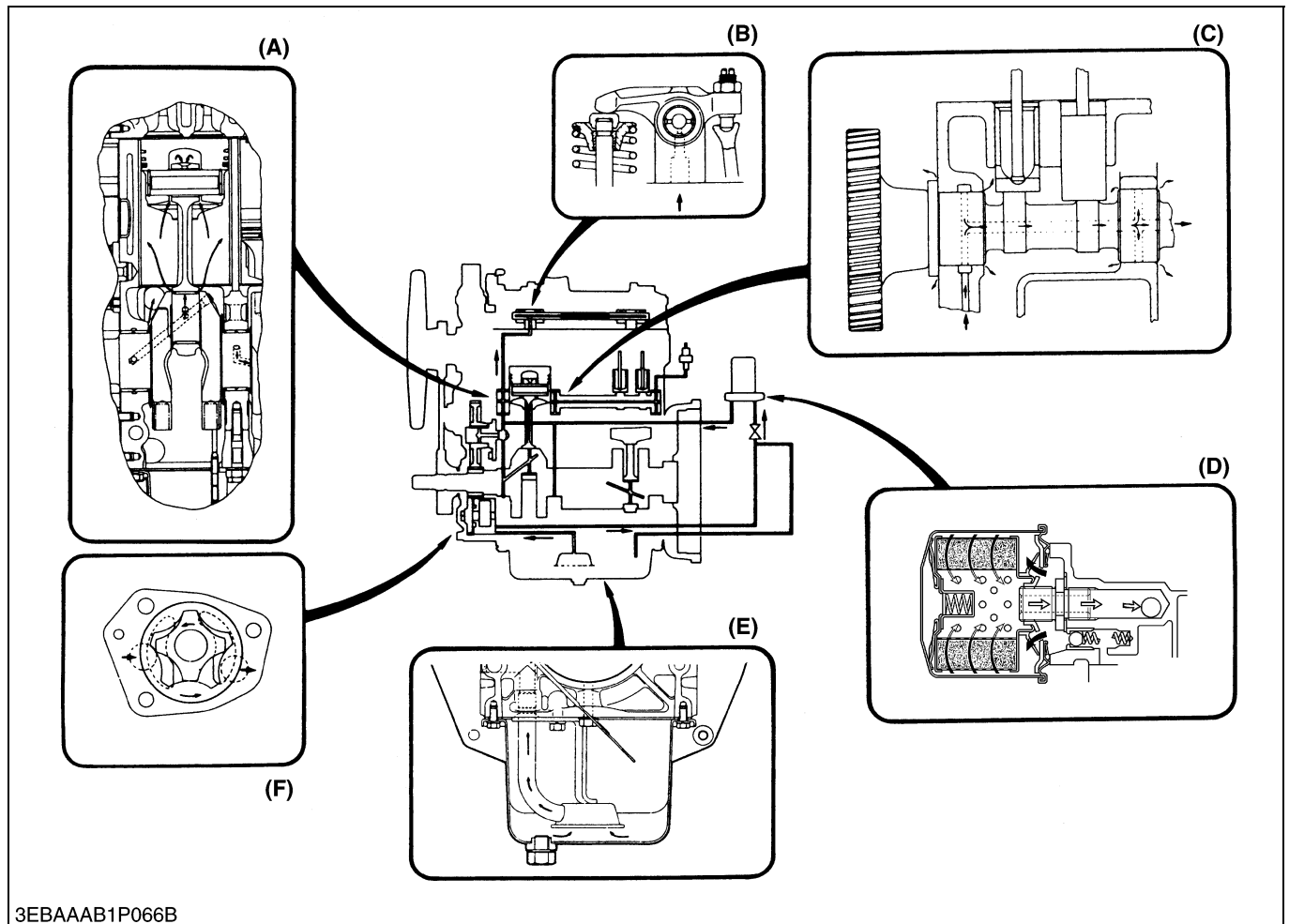

3EBAAAB1P066B

- | | | | |
|-------------------------------------|---|------------------|--------------|
| (A) Piston | (C) Camshaft | (E) Oil Strainer | (F) Oil Pump |
| (B) Rocker Arm and Rocker Arm Shaft | (D) Oil Filter Cartridge and Relief Valve | | |

The lubricating system consists of an oil strainer, an oil pump, a relief valve, an oil filter cartridge and an oil pressure switch. The oil pump sucks the lubricating oil in the oil pan through the strainer and sends it to the oil filter cartridge, where the oil is further filtered.

The filtered oil is forced to the crankshaft, the connecting rods, the idle gear, the camshaft and the rocker arm shaft through the oil passage in the cylinder block and the shafts to lubricate the bearings.

Some oil, splashed by the crankshaft or thrown off from the bearings, lubricates other engine parts: the pistons, the cylinder walls, the piston pins, the tappets, the push rods, the timing gears, and the inlet and exhaust valves.

9Y1210318ENM0016US0

[2] OIL PUMP

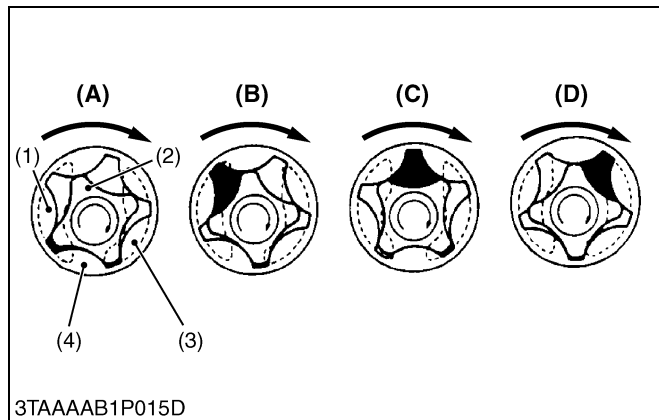

The oil pump is a trochoid pump, whose rotors have trochoid lobes. The inner rotor (2) has 4 lobes and the outer rotor (4) has 5 lobes, and they are eccentrically engaged with each other. The inner rotor, which is driven by the crankshaft through the gears, rotates the outer rotor in the same direction, varying the space between the lobes.

While the rotors rotate from (A) to (B), the space leading to the inlet port increases, which causes the vacuum to suck in the oil from the inlet port.

When the rotors rotate to (C), the space between both rotors switches from the inlet port to the outlet port. At (D), the space decreases and the sucked oil is discharged from the outlet port.

- (1) Inlet Port
- (2) Inner Rotor
- (3) Outlet Port
- (4) Outer Rotor

9Y1210318ENM0017US0

[3] RELIEF VALVE

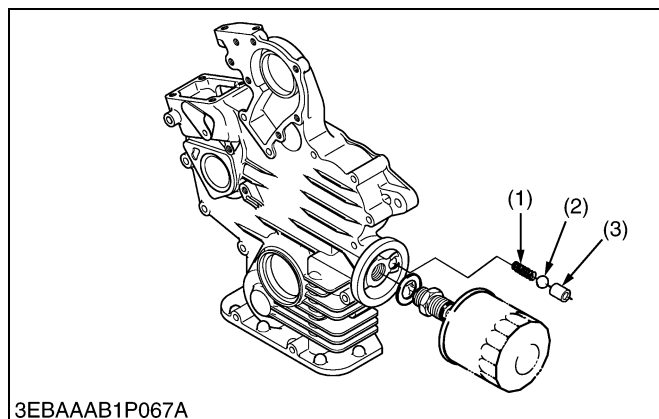

The relief valve prevents the damage to the lubricating system due to the high pressure of the oil.

This relief valve is a ball direct acting type, and is best suited for low pressures.

When the pressure of the oil, forced by the pump, exceeds the specified value, the oil pushes back the ball (2) and escapes to the oil pan.

- (1) Spring
- (2) Ball
- (3) Valve Seat

9Y1210318ENM0018US0

[4] OIL FILTER CARTRIDGE

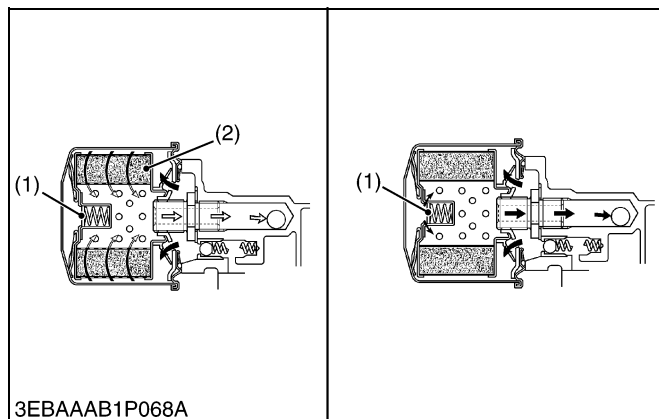

After lubricating, the lubricating oil brings back various particles of grit and dirt to the oil pan. Those particles and the impurities in the lubricating oil can cause wear or seizure of the engine parts. It may also impair the physical and chemical properties of the oil itself.

The lubricating oil which is force-fed by the pump, is filtered by the filter cartridge with the filter element (2).

When the filter element accumulates on excessive amount of dirt and the oil pressure in the inlet line builds up by 98 kPa (1.0 kgf/cm², 14 psi) more than the outlet line, the bypass valve (1) opens to allow the oil to flow from the inlet into the outlet line, bypassing the filter element.

- (1) Bypass Valve
- (2) Filter Element

9Y1210318ENM0019US0

[5] OIL PRESSURE SWITCH

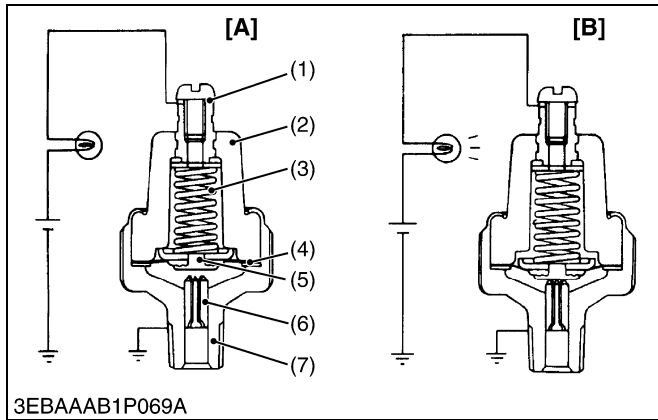

The oil pressure switch is mounted on the cylinder block and is led to the lubricating oil passage.

When the oil pressure falls below the specified value, the oil pressure warning lamp lights.

- (1) Terminal
- (2) Insulator
- (3) Spring
- (4) Rubber Gasket
- (5) Contact Rivet
- (6) Contact
- (7) Oil Switch Body

- [A] At the proper oil pressure**
- [B] At lower oil pressure, 50 kPa (0.5kgf/cm², 7 psi) or less**

9Y1210318ENM0020US0

3. COOLING SYSTEM

[1] GENERAL

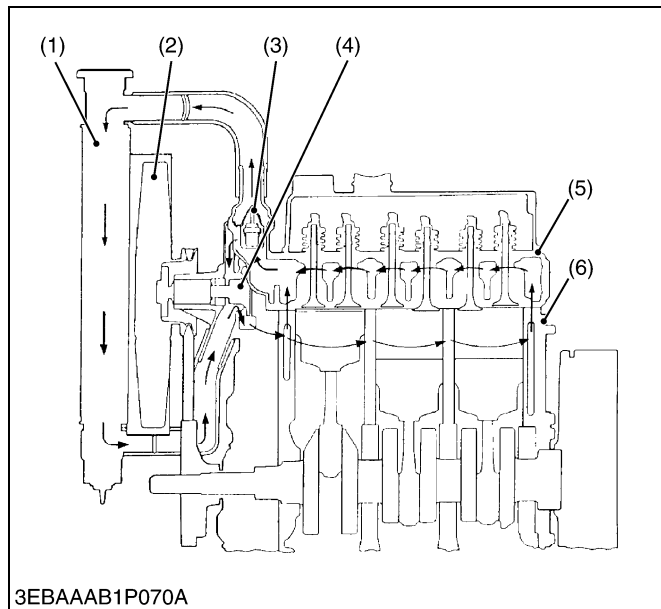

The cooling system consists of a radiator (1), a centrifugal water pump (4), a suction fan (2) and a thermostat (3).

The coolant is cooled through the radiator core, and the fan behind the radiator pulls the cooling air through the core to improve cooling.

The water pump sucks the coolant from the radiator or from the cylinder head and forces it into the cylinder block.

The thermostat opens or closes according to the coolant temperature, to allow the coolant to flow from the cylinder block to the radiator while open, or only to the water pump while closed.

Thermostat's valve opening temperature	Factory specification	69.5 to 72.5 °C 157.1 to 162.5 °F
--	-----------------------	--------------------------------------

- (1) Radiator
- (2) Cooling Fan
- (3) Thermostat
- (4) Water Pump
- (5) Cylinder Head
- (6) Cylinder Block

9Y1210318ENM0021US0

[2] COOLING FIN (WG972-G/GL-E3)

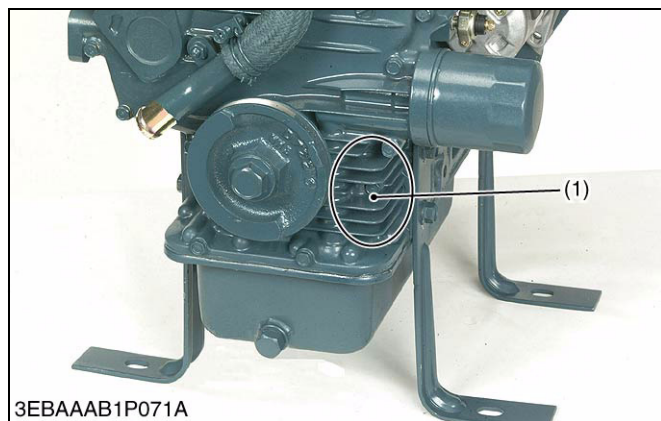

The cooling fin is set up around the oil passage in the gear case.

Therefore, the temperature of oil is decreased by the wind generated by the cooling fan.

- (1) Cooling Fin

9Y1210571ENM0032US0

[3] WATER PUMP

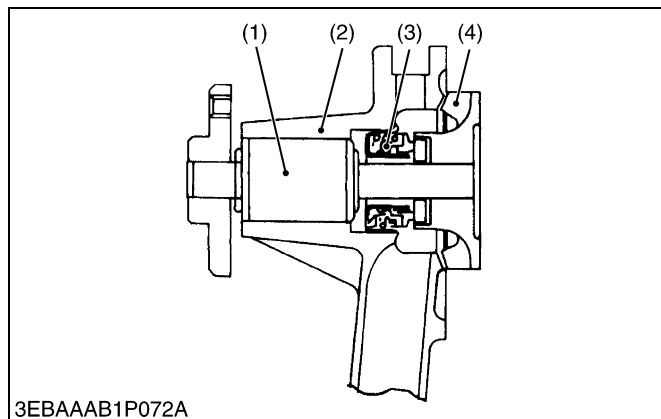

The water pump is driven by the crankshaft and a V belt. The rotating impeller (4) in the water pump sucks the coolant from the radiator and sends it into the water jacket in the cylinder block.

The mechanical seal (3) prevents the water from entering the bearing unit (1).

- (1) Bearing Unit
- (2) Water Pump Body
- (3) Mechanical Seal
- (4) Impeller

9Y1210318ENM0023US0

[4] THERMOSTAT

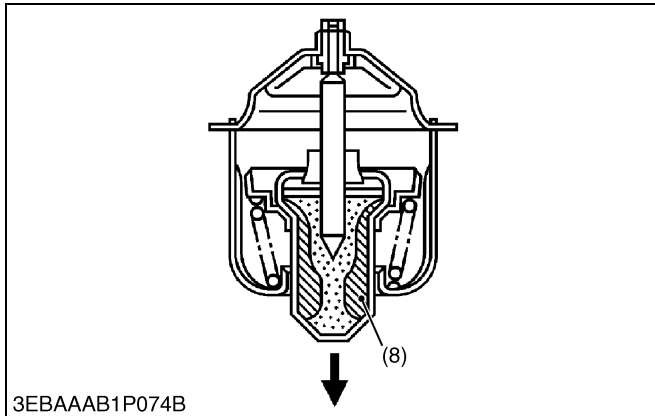
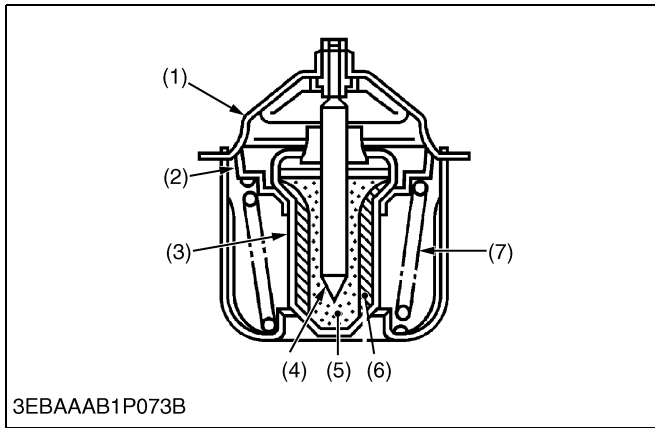

The thermostat is of the wax pellet type.

The thermostat controls the flow of the coolant to the radiator to keep the proper temperature.

The case, which serves as a valve seat, has a spindle inserted in the pellet (3) which is installed to the valve (2). The spindle is covered with the synthetic rubber (5) in the pellet.

The wax is charged between the pellet and the rubber.

■ **At low temperature (lower than valve opening temperature (at beginning))**

The valve (2) is seated by the spring (7) and the coolant circulates in the engine through the water return hose without running into the radiator. Only the air in the water jacket escapes to the radiator through the leak hole of the thermostat.

■ **At high temperature (higher than valve opening temperature (opened completely))**

As the coolant temperature rises, the wax in the pellet (3) turns liquid and expands, repelling the spindle, which causes the pellet to lower. The valve (2) opens to send the coolant to the radiator.

- | | |
|-------------|----------------------|
| (1) Seat | (5) Synthetic Rubber |
| (2) Valve | (6) Wax (Solid) |
| (3) Pellet | (7) Spring |
| (4) Spindle | (8) Wax (liquid) |

9Y1210571ENM0022US0

[5] RADIATOR

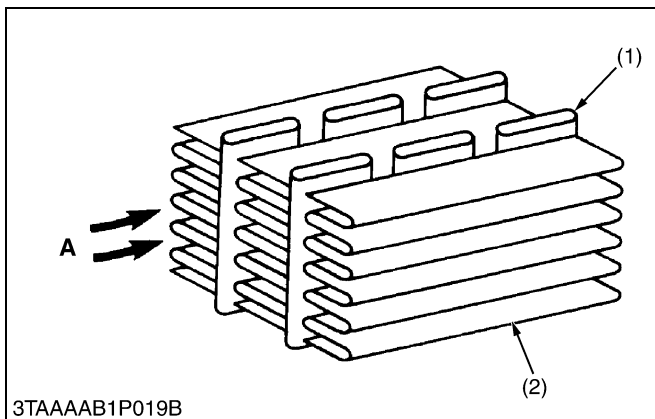

The radiator core consists of coolant carrying tubes (1) and fins (2) meeting at a right angle with the tubes. The fin is a louverless, corrugated type which is light in weight, high in heat exchange ratio and less apt to clog.

The coolant in the tubes is cooled by the air flowing through the tube walls and fins.

- | | |
|----------|------------------------|
| (1) Tube | A : Cooling Air |
| (2) Fin | |

9Y1210318ENM0025US0

[6] RADIATOR CAP

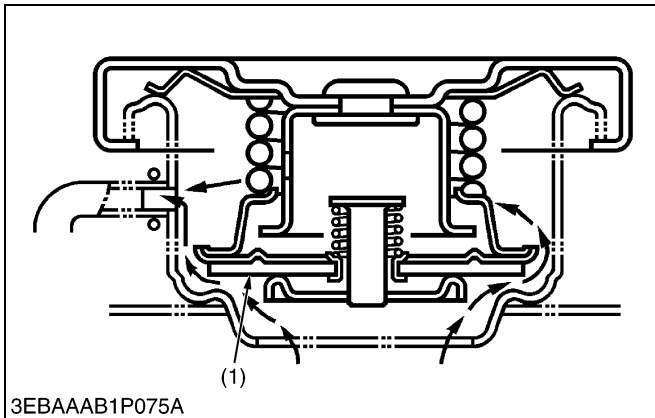

The pressure type radiator cap prevents differences in pressure between the inside and the outside of the radiator from deforming the radiator.

When the coolant temperature rises and the pressure in the radiator increases above the specified pressure, the pressure valve (1) opens to reduce the internal pressure.

When the coolant temperature falls and a vacuum forms in the radiator, the vacuum valve (2) opens to introduce the air into the radiator.

- (1) Pressure Valve (Opening pressure 88 kPa (0.90 kgf/cm², 13 psi)) (2) Vacuum Valve

9Y1210318ENM0026US0

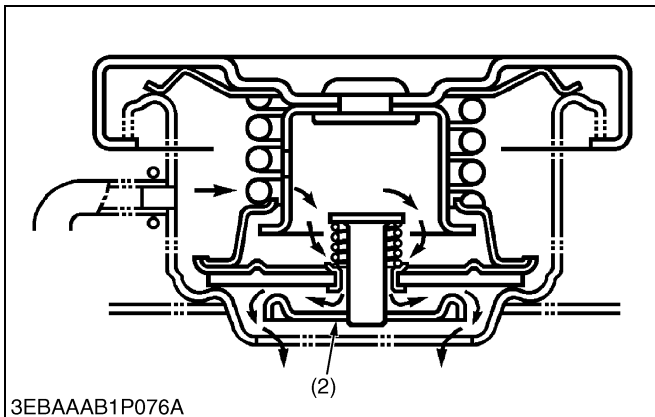

[7] VAPORIZER (WG752-GL-E3, WG972-GL-E3)

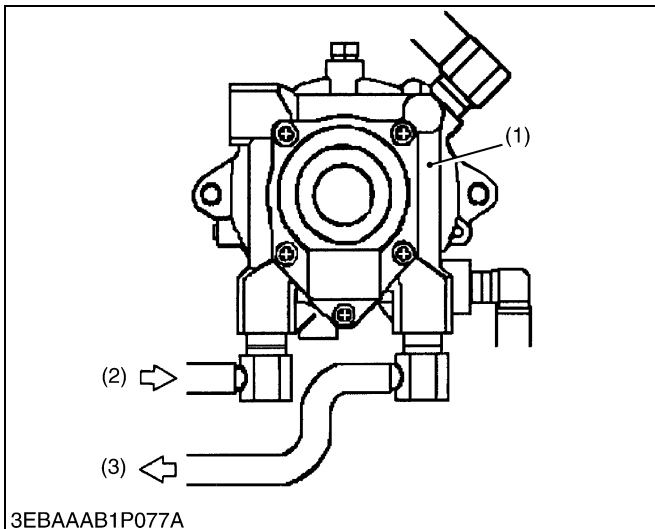

When evaporating by primary chamber of vaporizer liquid LPG needs the evaporation heat.

This vaporizer installs the water jacket, throws the coolant of engine, heats primary chamber, promotes evaporation, and prevents valves being frozen.

- (1) Vaporizer (3) Hot Coolant Out
(2) Hot Coolant In

9Y1210571ENM0006US0

4. FUEL SYSTEM

[1] GENERAL

(1) WG752-G/GL-E3, WG972-G/GL-E3

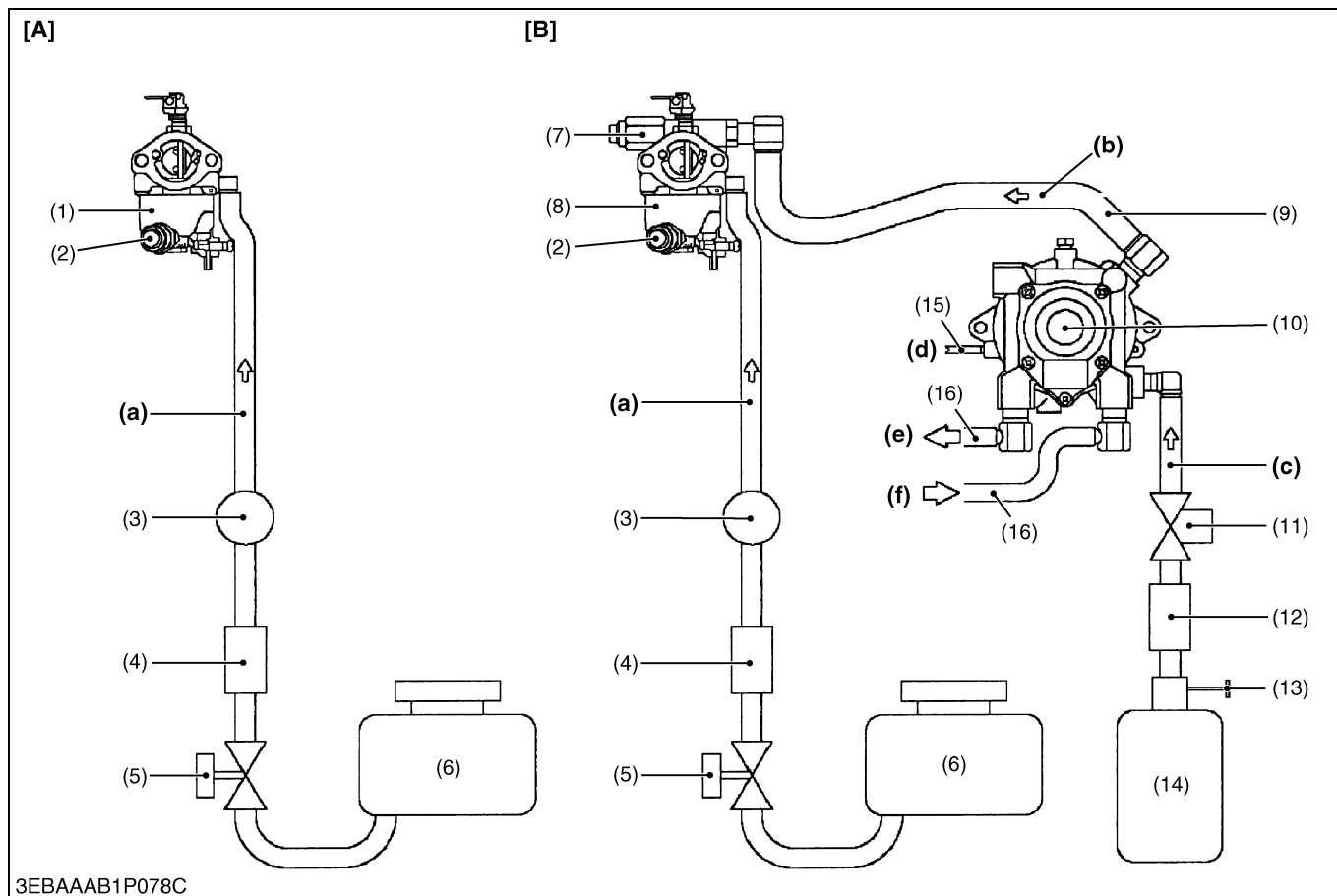

3EBAAAB1P078C

- | | | | |
|-------------------------------|-----------------------------------|--------------------------|--|
| (1) Carburetor | (9) Vapor Hose* | (a) Gasoline Line | [A] WG752-G-E3, WG972-G-E3 |
| (2) Gasoline Cut Off Solenoid | (10) Vaporizer | (b) Gaseous Propane Line | [B] WG752-GL-E3, WG972-GL-E3 |
| (3) Fuel Feed Pump | (11) LPG Shut Off Solenoid Valve* | (c) Liquid Propane Line | |
| (4) Fuel Filter | (12) LPG Filter* | (d) Vacuum Line | |
| (5) Gasoline Cock* | (13) LPG Manual Valve* | (e) Hot Coolant Out Line | Component Marked * Is Not Provided by KUBOTA |
| (6) Gasoline Tank* | (14) LPG Tank* | (f) Hot Coolant In Line | |
| (7) LPG Cut Off Solenoid | (15) Vacuum Hose* | | |
| (8) Dual Fuel Carburetor | (16) Coolant Hose* | | |

WG752-G-E3, WG972-G-E3:

The fuel is fed from the gasoline tank (6) through the fuel filter (4) to the WG carburetor (1) by the fuel feed pump (3).

WG752-GL-E3, WG972-GL-E3:

This fuel system has 2 ways. Gasoline fuel is the same as WG752-G-E3 and WG972-G-E3.

For LPG fuel, the liquid fuel stored in the LPG tank (14) is sent to vaporizer (10) by pressure in the gaseous phase in the tank through the LPG filter (12) and LPG shut off solenoid valve (11).

The liquid fuel is evaporated in vaporizer and is sent to the dual fuel carburetor (8) as a gaseous fuel of gas pressure near the atmospheric pressure. The dual fuel carburetor (8) mixes the gas and air is supplied in the cylinder.

9Y1210571ENM0015US0

[2] CARBURETOR AND DUAL FUEL CARBURETOR

(1) Carburetor (WG752-G-E3, WG972-G-E3)

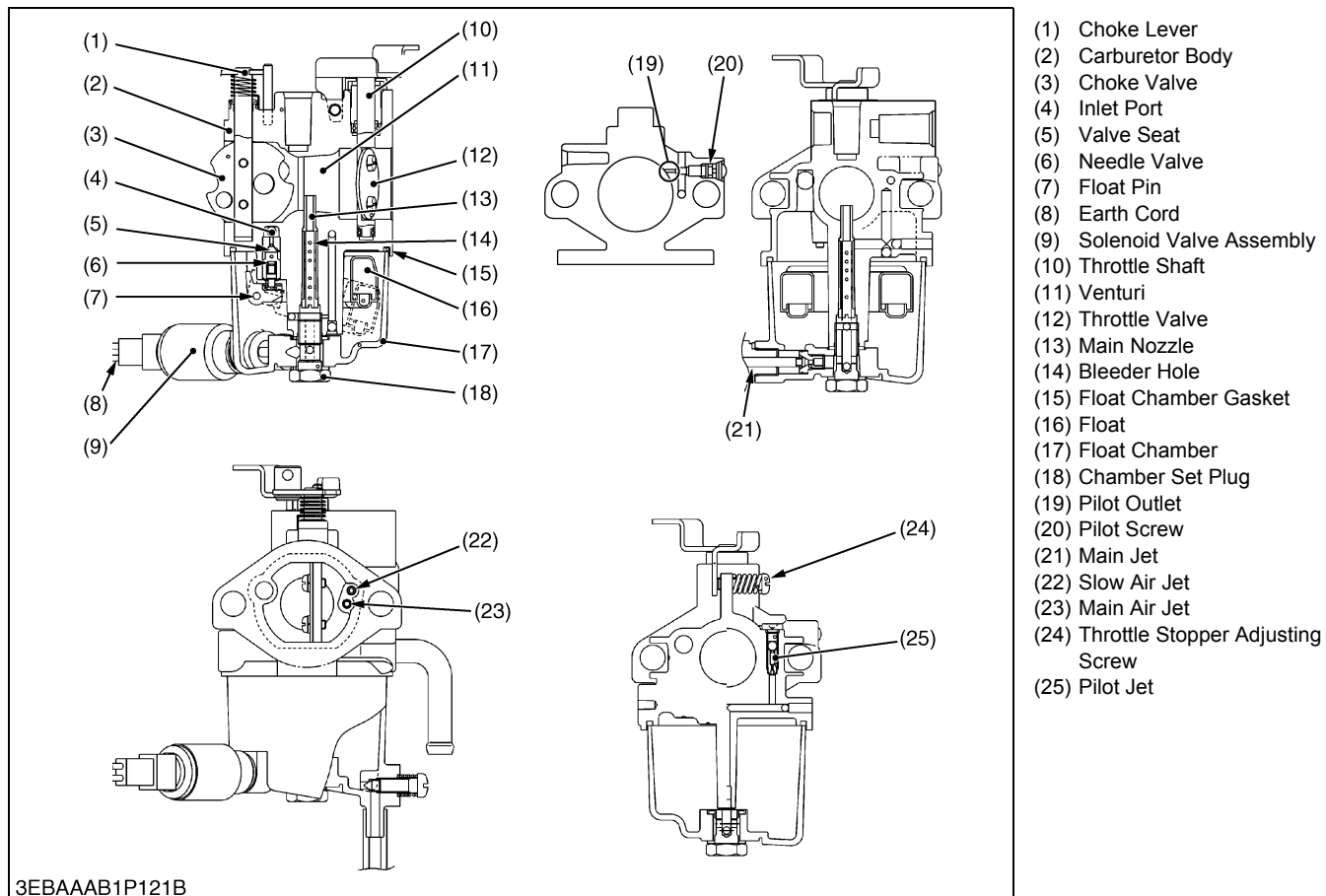

- (1) Choke Lever
- (2) Carburetor Body
- (3) Choke Valve
- (4) Inlet Port
- (5) Valve Seat
- (6) Needle Valve
- (7) Float Pin
- (8) Earth Cord
- (9) Solenoid Valve Assembly
- (10) Throttle Shaft
- (11) Venturi
- (12) Throttle Valve
- (13) Main Nozzle
- (14) Bleeder Hole
- (15) Float Chamber Gasket
- (16) Float
- (17) Float Chamber
- (18) Chamber Set Plug
- (19) Pilot Outlet
- (20) Pilot Screw
- (21) Main Jet
- (22) Slow Air Jet
- (23) Main Air Jet
- (24) Throttle Stopper Adjusting Screw
- (25) Pilot Jet

Designed for general purpose use, this carburetor provides engines with the ideal fuel-air mixture for all speed ranges.

1) Float Chamber

When the gasoline in the fuel tank flows into the float chamber (17), the float (16) rises and, when a predetermined amount of gasoline is in the chamber, it pushes the needle valve (6) against the valve seat (5) to stop additional gasoline from entering through the inlet port (4). As the gasoline is consumed, the float goes down and more gasoline is led into the chamber to maintain a constant distance between the main nozzle (13) and the level of the gasoline.

2) Starting System

To start an engine in cold weather, the fuel-air mixture must be richer than normal. A choke valve (3) controlled by the choke lever (1) is provided to enrich the mixture.

As the choke valve is closed, the air supply is restricted to make the mixture rich. This rich mixture is then supplied to the intake manifold to facilitate starting.

3) Slow System

When the throttle valve (12) closes, air that flows into the cylinder passes along the valve at a high speed. As a result, a negative pressure is created in the pilot outlet (19) which has an outlet port in the inner wall. This causes gasoline in the main nozzle (13) to flow through the pilot jet (25) to be sucked into the cylinder. Air that enters from the slow air jet (22) is mixed with gasoline in the pilot jet (25), atomized in an appropriate condition, sprayed from the pilot outlet (19) and sucked into the cylinder through the main passage. The slow speed of the engine is controlled by changing the jet area with the pilot jet (25).

4) Main Carburetor System

The speed of air that flows into the cylinder increases when it passes the venturi (11), and the negative pressure increases as a result at the tip of the main nozzle (13). The negative pressure causes the gasoline in the float chamber (17) to flow through the main jet (21) and to be sucked into the main nozzle (13). Air which flows from the main air jet (23) into the bleeder hole (14) of the main nozzle (13) is mixed with gasoline, atomized in an appropriate condition, then sprayed from the nozzle tip to the venturi (11) and sucked with the main air into the cylinder.

9Y1210318ENM0030US0

(2) Dual Fuel Carburetor (WG752-GL-E3, WG972-GL-E3)

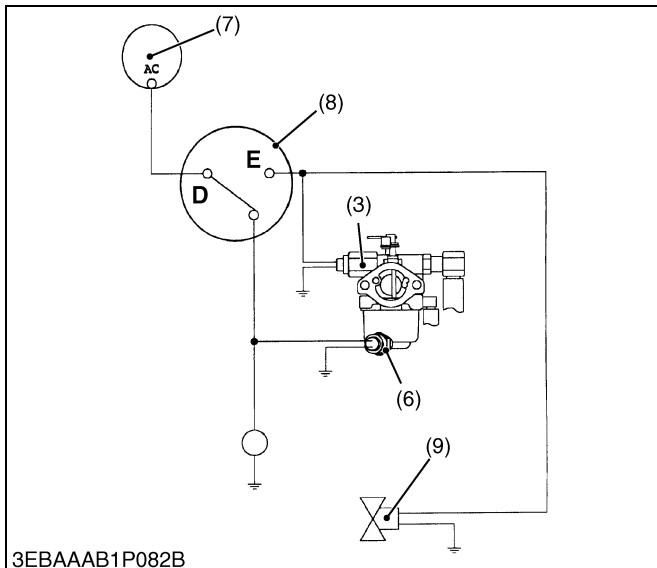
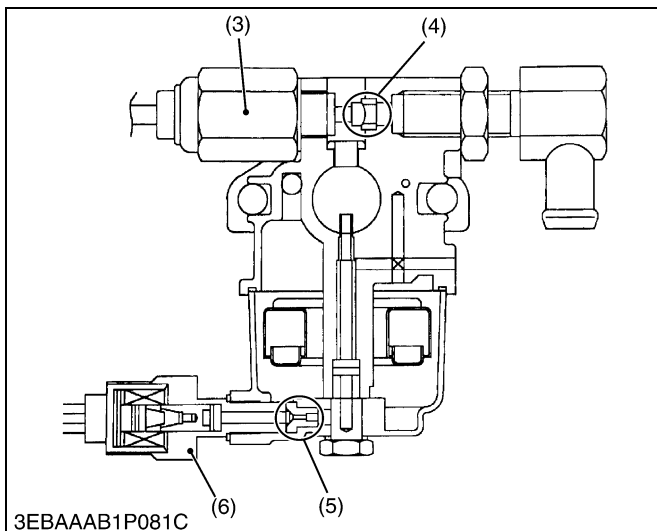
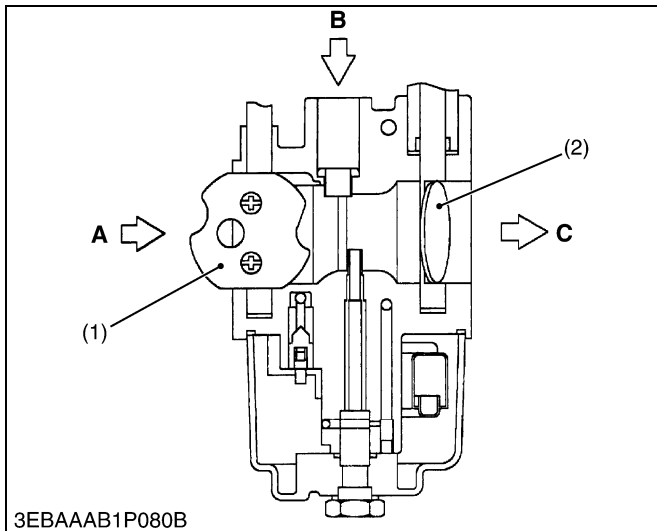

■ **NOTE**

- **Dual fuel Carburetor operates the same as a gasoline carburetor in gasoline fuel.**

With the fuel select switch (8) in the "GASOLINE" position "D" and the main switch in the "ON" position, the battery current flows to the gasoline cut off solenoid (6). Therefore gasoline fuel in the float chamber flows to the mixing chamber.

When the fuel select switch (8) is turned to the "LPG" position "E", the battery current stops to the gasoline cut off solenoid (6) and flows to the LPG cut off solenoid (3) and LPG shut off solenoid valve (9).

Then, the gasoline fuel flow is shut and LPG fuel flows to the mixing chamber.

The mixer meters both fuel and air, and procedures an air / fuel mixture that has the proper ratio as required by the engine.

When the engine starts, the LPG fuel flows out from main jet (4) to venture a constant amount and is mixed with air quantity corresponding to the opening of the throttle valve (1) and is supplied to the cylinder.

When the main switch (7) turned to the "OFF" position, the battery current stops to the both of solenoids.

Then, both gasoline fuel and LPG fuel can not flow to the mixing chamber.

- | | |
|---------------------------------|---------------------------------|
| (1) Choke Valve | A : Air |
| (2) Throttle Valve | B : LPG Fuel (gaseous) |
| (3) LPG Cut Off Solenoid | C : Mixture (Air / Fuel) |
| (4) LPG Main Jet | D : Gasoline Position |
| (5) Gasoline Main Jet | E : LPG Position |
| (6) Gasoline Cut Off Solenoid | |
| (7) Main Switch | |
| (8) Fuel Select Switch | |
| (9) LPG Shut Off Solenoid Valve | |

9Y1210571ENM0023US0

[3] VAPORIZER (WG752-GL-E3, WG972-GL-E3)

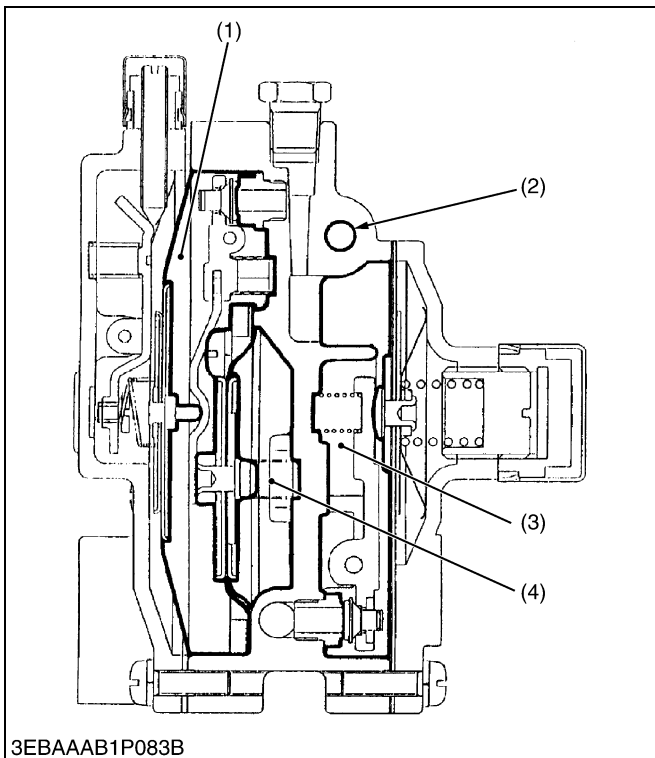

Vaporizer is a device which converts the liquid fuel into the gaseous fuel and the following structures and functions are possessed.

■ Primary Chamber

The liquid fuel is decompressed (the first decompression) and it is evaporated.

■ Secondary Chamber

The fuel which flows in is decompressed from the primary chamber to the vicinity of the atmospheric pressure further (the second decompression).

■ Water Passage

The coolant of the engine is made to circulate as a heat source to evaporate the LPG.

■ Vacuum Lock Chamber

When the engine stops, the fuel from primary chamber is prevented from flowing out.

- | | |
|-----------------------|-------------------------|
| (1) Secondary Chamber | (3) Primary Chamber |
| (2) Water Passage | (4) Vacuum Lock Chamber |

9Y1210318ENM0033US0

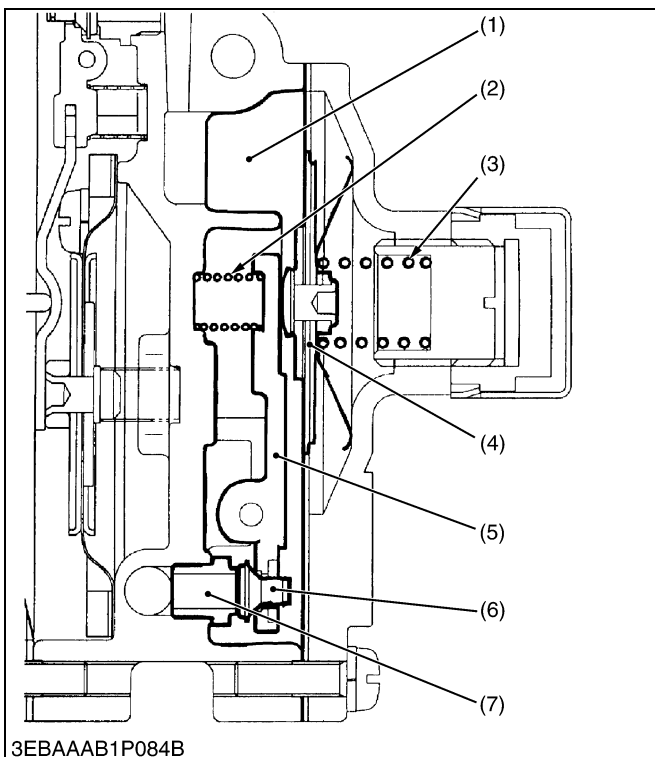

Primary Chamber

The liquid fuel which pushes the primary valve (6) open passes between the valve and the valve seat (7), enters primary chamber (1), and decompresses and is evaporated.

When the inflow of the fuel continues and the primary chamber pressure rises more than the specified pressure 32.7 kPa (0.3 kgf/cm², 4.3 psi), the tension in the diaphragm spring (3) is overcome and do the push up of primary diaphragm (4).

At this time, do the push up of primary valve lever spring (2) of primary valve lever (5), primary valve (6) is shut, and the inflow of the fuel is intercepted.

The tension in the diaphragm spring (3) grows more than the primary chamber pressure when the fuel is consumed and the primary chamber pressure lowers more than a regulated value and a primary diaphragm is depressed below.

The primary valve lever (5) is depressed at the same time.

A primary valve opens and the fuel flows in again.

When the diaphragm tears by any chance and the fuel flows in the primary diaphragm spring side, the primary diaphragm spring side is connected with second chamber in the balance passage so that the fuel should not flow out outside.

- | | |
|--------------------------------|-------------------------|
| (1) Primary Chamber | (5) Primary Valve Lever |
| (2) Primary Valve Lever Spring | (6) Primary Valve |
| (3) Primary Diaphragm Spring | (7) Valve Seat |
| (4) Primary Diaphragm | |

9Y1210318ENM0034US0

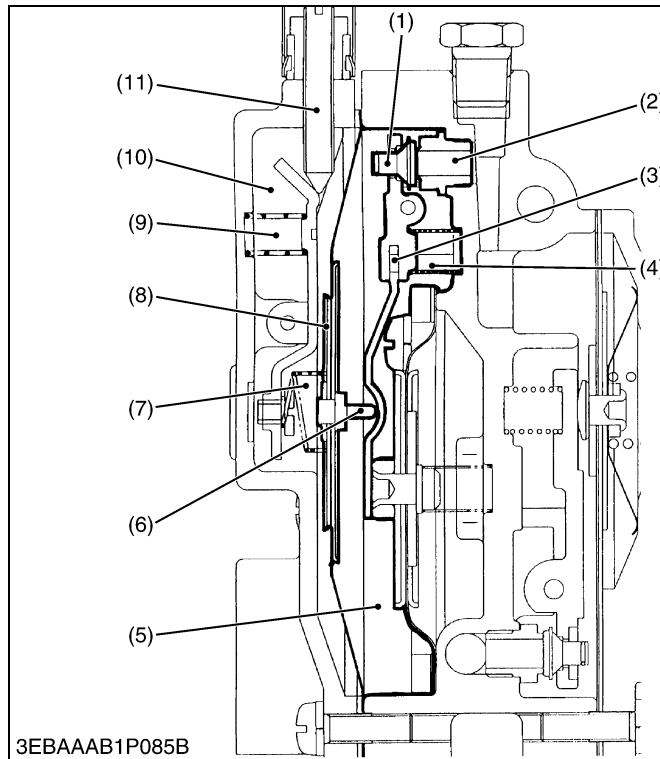

Secondary Chamber

The fuel adjusted with primary chamber to the specified pressure enters secondary chamber (5) between secondary valve (1) and the valve seat (2) and is decompressed to the vicinity of the atmospheric pressure almost.

A secondary valve is assembled to a part of the secondary valve lever (3) supported to body and is shut by the tension of the spring of a secondary valve spring (4).

A secondary diaphragm pin (6) touches the edge besides this lever (3).

The one side of secondary diaphragm (8) is faced in secondary chamber and the other side faces atmosphere chamber (10).

When the engine stops, the atmospheric pressure is led in secondary chamber and a secondary valve is shut by the tension of a secondary valve spring.

When the engine rotates, the negative pressure is generated in the venturi tube of the mixer.

As for this negative pressure, working secondary diaphragm (8) is pulled to the second chamber side by the difference pressure with atmosphere chamber by second chamber.

Do the push up of the secondary valve lever (3) by this working, secondary valve is opened, and the fuel flows in.

When pressure in chamber rises by the fuel which flows in, the diaphragm is pushed to the atmosphere chamber side and narrows the opening of the valve and decreases the supply of the fuel.

Secondary chamber is almost maintained in the atmospheric pressure by the thing to repeat such working.

- | | |
|----------------------------------|--------------------------|
| (1) Secondary Valve | (6) Diaphragm Pin |
| (2) Valve Seat | (7) Balance Spring |
| (3) Secondary Valve Lever | (8) Secondary Diaphragm |
| (4) Secondary Valve Lever Spring | (9) Balance Lever Spring |
| (5) Secondary Chamber | (10) Atmosphere Chamber |
| | (11) Idle Adjust Screw |

9Y1210318ENM0035US0

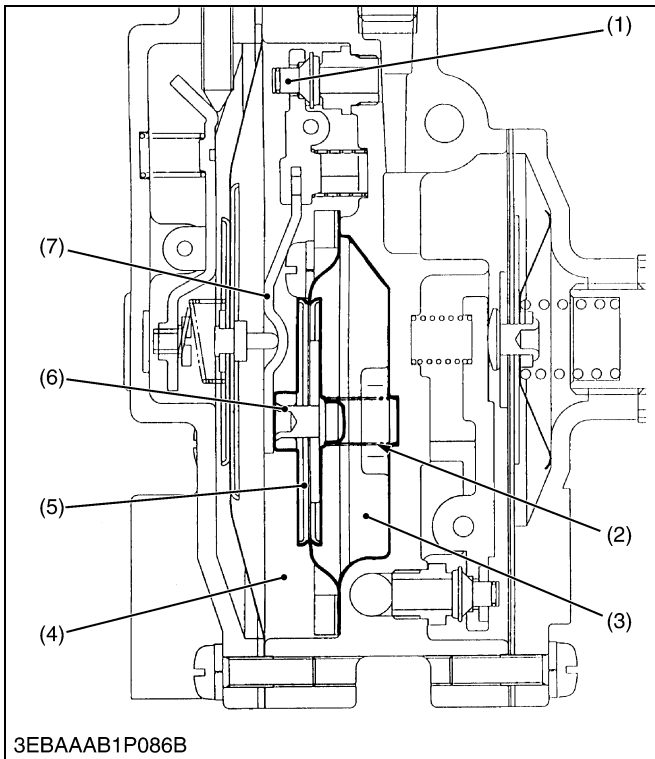

Vacuum Lock Chamber

1) Operation when engine stops

Because pressure on the vacuum lock chamber (3) side and the secondary chamber (4) side is equal, vacuum lock diaphragm (5) is pushed to the second chamber side by the tension of vacuum lock diaphragm spring (2).

Secondary valve and the seat are made to close as vacuum lock diaphragm pin (6) pushes secondary valve lever (7) and the fuel leakage is prevented.

2) Operation at engine starting

The negative pressure is caused in inlet manifold at the same time as the cranking's beginning.

This negative pressure acts in vacuum lock chamber (3) and vacuum lock diaphragm (5) is drawn to the vacuum lock chamber side.

As a result, the movement of secondary valve lever (7) becomes free and the fuel inflow adjustment due to secondary valve (1) becomes possible.

The negative pressure in inlet manifold always works while the engine is rotating and the movement of secondary valve lever is tuned to the movement of secondary diaphragm.

- | | |
|----------------------------------|---------------------------|
| (1) Secondary Valve | (5) Vacuum Lock Diaphragm |
| (2) Vacuum Lock Diaphragm Spring | (6) Diaphragm Pin |
| (3) Vacuum Lock Chamber | (7) Secondary Valve Lever |
| (4) Secondary Chamber | |

9Y1210318ENM0036US0

[4] GOVERNOR

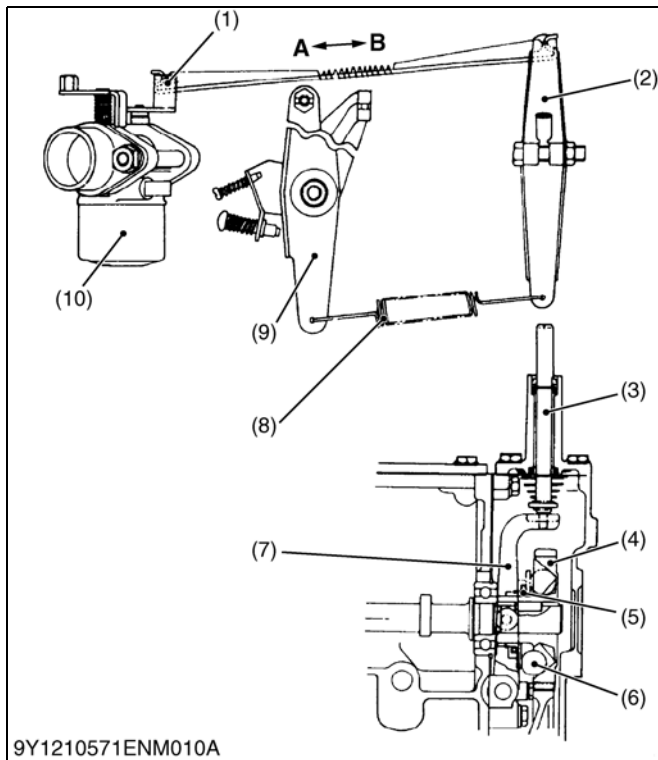

The engine is equipped with a centrifugal ball mechanical governor which activates the throttle in response to engine speed.

When the engine is carrying a load and running at rated speed, the speed will drop if the load is increased even slightly. In this case, the governor automatically opens the throttle valve of the carburetor to maintain the original speed.

Dumping the load suddenly will cause a rapid increase in speed. In this case, the governor automatically moves the throttle valve in closing direction to prevent the engine from increasing its speed.

1) When engine is carrying a load and running at rated speed

When there is no change in load, the centrifugal force of the ball (6) which is attached to the governor gear (4) balances with the tensile force of the governor spring (8) via governor sleeve (5), fork lever (7), governor lever shaft (3) and governor lever (2). The engine speed and output are thus kept constant.

2) When load is applied to engine

When the load is applied to the engine running at rated speed, the speed of the governor gear (4) which is connected to the idle gear decreases. As a result, the centrifugal force of the ball (6) becomes smaller. The tensile force of the spring (8) overcomes the centrifugal force, and the governor lever (2) causes the throttle lever (1) to move in the open direction "B". The original engine speed is thus maintained.

3) When load is dumped

When the load is dumped suddenly, the centrifugal force of the ball (6) overcomes the tensile force of the spring (8). As a result, the governor lever (2) causes the throttle lever (1) to move in the shut direction "A" and prevents the engine from increasing its speed.

- | | |
|--------------------------|---------------------------|
| (1) Throttle Lever | (9) Speed Control Lever |
| (2) Governor Lever | (10) Carburetor |
| (3) Governor Lever Shaft | |
| (4) Governor Gear | A : Shut Direction |
| (5) Governor Sleeve | B : Open Direction |
| (6) Ball | |
| (7) Fork Lever | |
| (8) Governor Spring | |

9Y1210318ENM0038US0

[5] INLET MANIFOLD

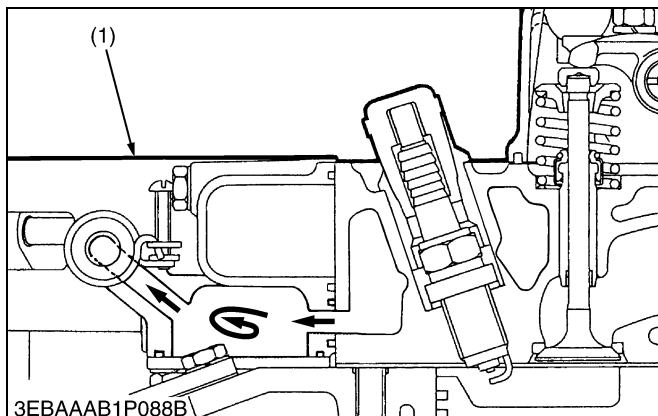

Part of coolant heated in the water jacket is channeled to the inlet manifold, where the hot coolant heats the fuel-air mixture for better carburation. Heating effect is particularly good when the engine is running at low speeds and with light load in cold weather, thus improving fuel economy and acceleration.

- (1) Intake Manifold

9Y1210318ENM0039US0

[6] FUEL FILTER (FOR GASOLINE LINE)

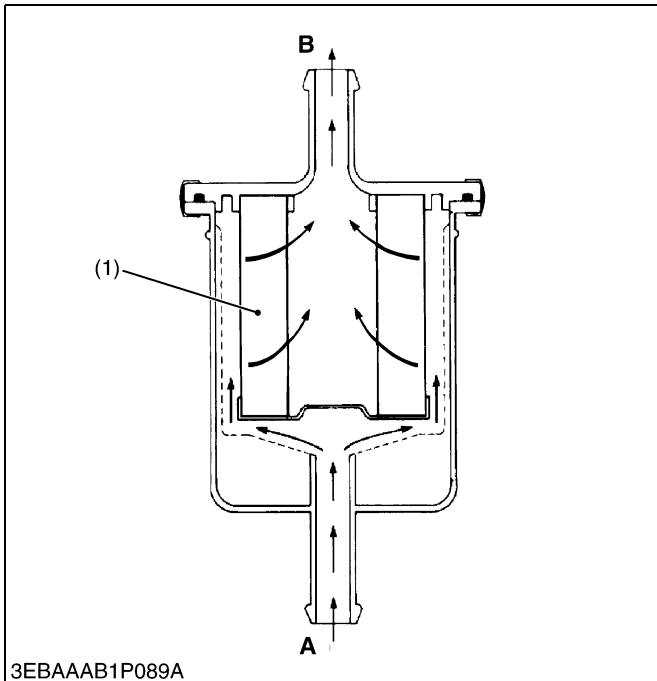

3EBAAAB1P089A

The fuel filter is installed in the fuel line between the fuel tank and the feed pump.

As the fuel flows from the inlet "A" through the filter element (1), the dirt and impurities in the fuel are filtered, allowing only clean fuel to penetrate the inside of the filter element. The cleaned fuel flows out from the outlet "B".

Type of filter element	Accordion-pleated paper type
Material of filter element	Cotton fiber
Filter mesh	15 μm (0.00059 in.)

(1) Filter Element

A : Inlet
B : Outlet

9Y1210318ENM0040US0

[7] ELECTRO MAGNETIC FUEL FEED PUMP (FOR GASOLINE LINE)

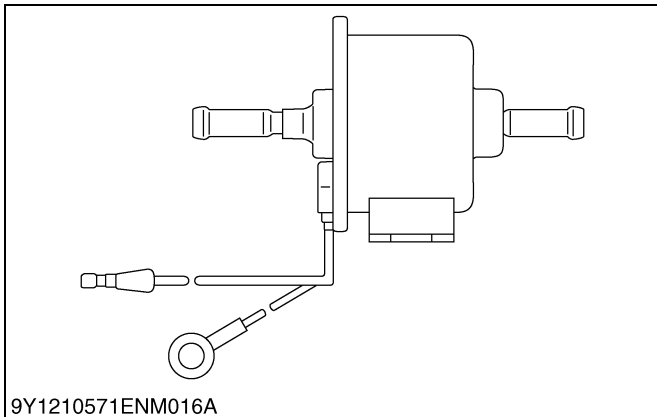

9Y1210571ENM016A

An electro magnetic pump uses a transistor that causes the pump to start pumping fuel when the engine is switched on.

Therefore, fuel is supplied to the carburetor regardless of engine speed. This pump is driven by the battery. It can therefore be operated even with the engine being stopped.

9Y1210571ENM0033US0

5. EXHAUST SYSTEM

[1] CATALYST

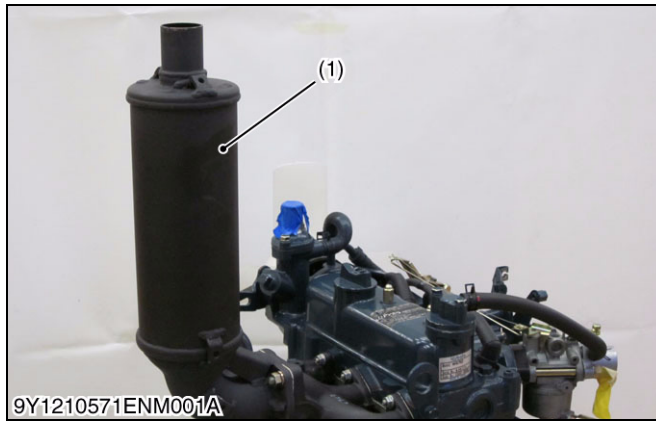

The catalytic devices can reduce harmful components contained in exhaust gas by three way catalyst.

KUBOTA engines have two kinds of catalytic devices, catalytic muffler and catalytic converter.

(1) Catalytic Muffler

(2) Catalytic Converter

9Y1210571ENM008US0

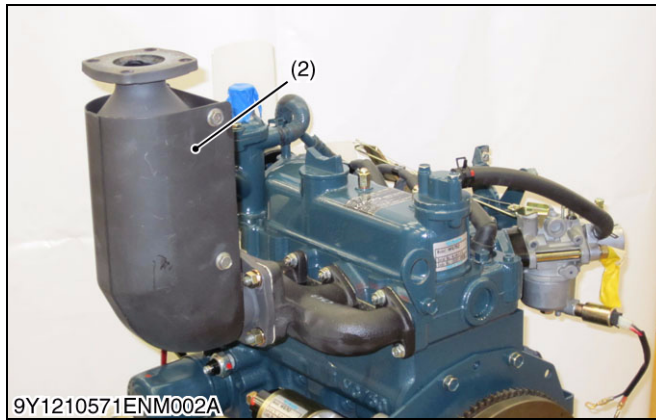

6. IGNITION SYSTEM

[1] DISTRIBUTOR (WG752-G/GL-E3)

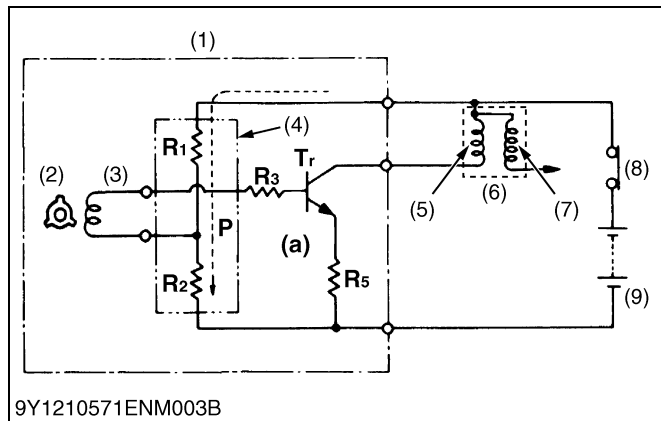

9Y1210571ENM003B

When the Engine is Off

When the ignition switch (8) is turned on, the fixed bias voltage - the voltage at point **P** (the voltage supplied by the battery (9) and divided by resistors R_1 and R_2) - is slightly higher than the operating voltage of transistor. The transistor thus turns on and delivers a current to the primary coil (5) of the ignition coil (6).

- (1) Distributor
- (2) Signal Rotor
- (3) Pick-up Coil
- (4) Fixed Bias Circuit
- (5) Primary Coil
- (6) Ignition Coil
- (7) Secondary Coil
- (8) Ignition Switch
- (9) Battery

Tr : Transistor
 R_1, R_2, R_3, R_5 : Resistor
(a) ON

9Y1210571ENM0024US0

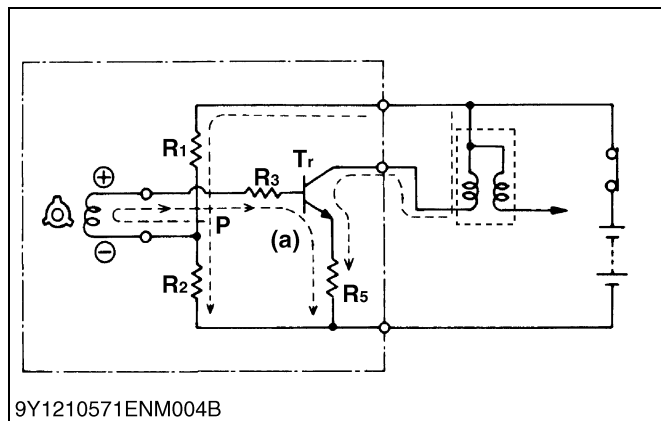

9Y1210571ENM004B

When the Voltage Produced By the Pick-up Coil is Positive

After the engine is started, the signal rotor of the distributor rotates and an AC voltage develops in the pick-up coil.

When the output voltage of the pick-up coil is positive, the voltage at point **P** combined with this output voltage is applied to the base of the transistor. The combined voltage is higher than the operating voltage of the transistor so that the transistor remains on and the current to the primary coil of the ignition coil continues to flow.

(a) ON

9Y1210571ENM0025US0

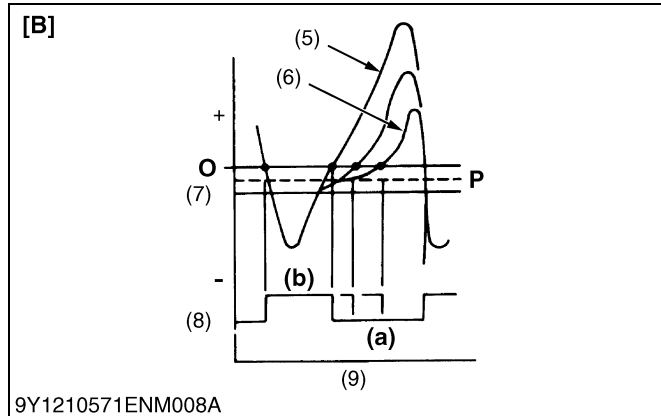
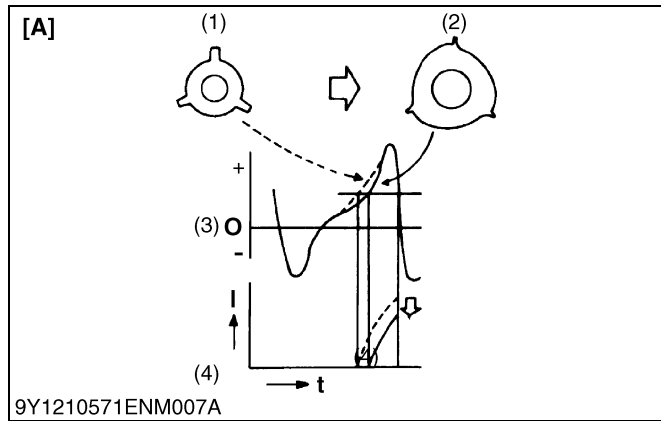

Dwell Control By the Pick-up Coil Waveform

This ignition system features a unique dwell control method which utilizes changes in the output waveform of the pick-up coil. In order for the waveform to have a sharper rising edge, the teeth of the signal rotor of the distributor are designed as shown in Fig. A.

Unlike conventional fully-transistorized ignition circuits, the fixed bias voltage **P** of this ignition circuit is set at a lower level than the operating voltage of the transistor. For this reason, a voltage does not develop on the pick-up coil even when the key switch is turned on, preventing a current from flowing into the ignition coil.

Therefore, as the signal rotor increases in speed, the output voltage of the pick-up coil becomes greater and the rising edge of the waveform becomes sharper. (See Fig. B.) As a result, the transistor turns on faster than in a conventional fully-transistorized ignition circuit. Yet it turns off at the same time as the transistor in a conventional circuit. Consequently, the amount of time the transistor is turned on increases (the dwell becomes wider).

As explained above, this ignition system makes use of changes in the output waveform of the pick-up coil to increase the closing angle at high engine speeds.

- | | |
|---|-----------------------------|
| (1) Ordinary Shape | (6) Increase in RPM |
| (2) Dwell Controlled Shape | (7) Operating Level of Tr 1 |
| (3) Waveform of the Pick-up Coil | (8) Tr 1 Operation |
| (4) Waveform of the Primary Current | (9) Rotor Angle |
| (5) Output Waveform of the Pick-up Coil | (a) ON |
| | (b) OFF |

9Y1210571ENM0027US0

[2] DIGITAL IGNITION SYSTEM (WG972-G/GL-E3)

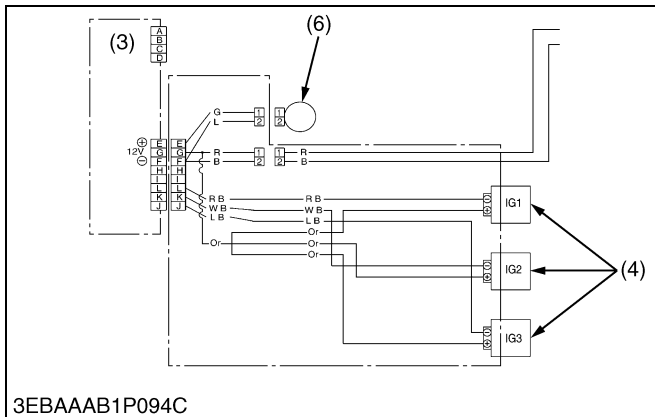
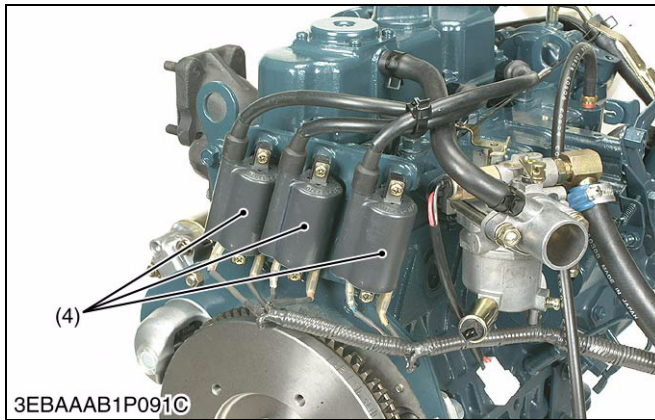
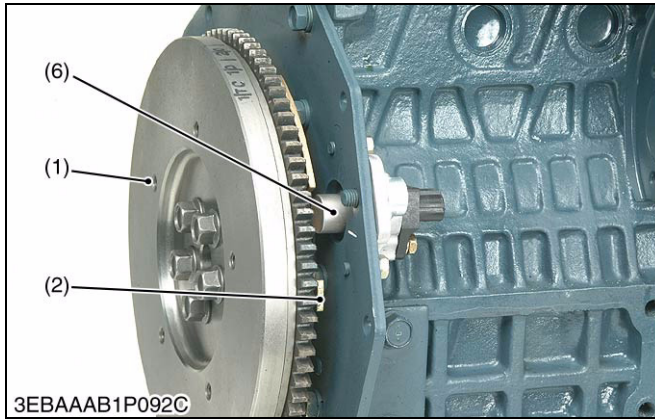
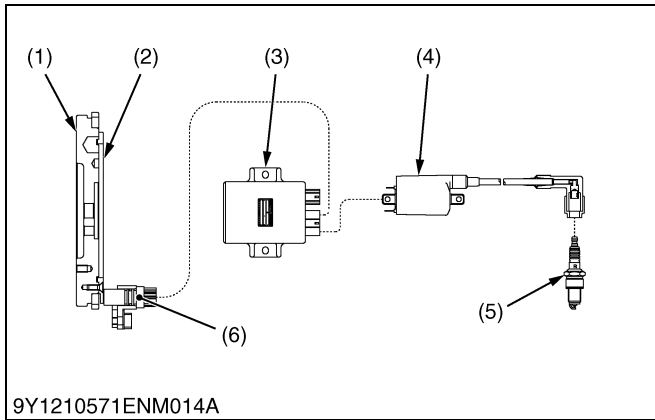

General

The function of an ignition system is to provide the electrical spark that ignites the air/fuel mixture in the cylinder at precisely the correct time.

For this purpose, the pick-up sensor (6) detects voltage waveform according to the shape of the rotor (2) that is built into the flywheel (1). The voltage waveform signal is fed to the igniter (3), in which the signal is converted by a microprocessor to the angular and rpm data that corresponds to each cylinder. Based on this information, an optimum timing is figured out by the microprocessor to cut off the current that flows to the ignition coil (4) of each cylinder. The duration of current flowing to the ignition coil (4) is also controlled. In this way, a high voltage is generated at the secondary winding of the ignition coil (4), which activates the spark plug (5).

Without any mechanical contact, the ignition system is digitally microprocessor-controlled for greater reliability and higher precision.

- Control at ignition time :
The ignition time is controlled according to the engine speed.
- Control at energizing time :
The energizing time of the ignition coil is controlled according to the engine speed.
- Lock prevention :
Intercept the current of the coil for the damage prevention of the coil when the ignition switch is energized to the coil as turning on.

- | | |
|--------------|--------------------|
| (1) Flywheel | (4) Ignition Coil |
| (2) Rotor | (5) Spark Plug |
| (3) Ignitor | (6) Pick-up Sensor |

9Y1210571ENM0034US0

7. ELECTRICAL SYSTEM

[1] STARTING SYSTEM

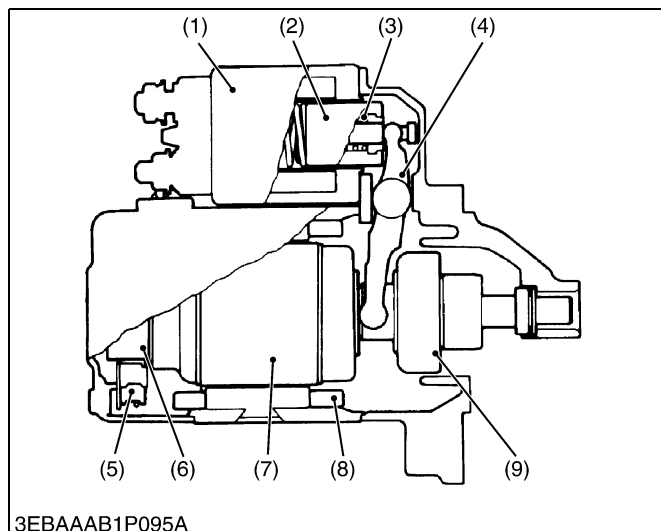

Starter

The starter is the electromagnetic drive type.

Type of motor	DC, Series-wound, Electromagnetic drive
Nominal output	12V
Nominal output	0.7 kW (WG752-G/GL-E3) 1.0 kW (WG972-G/GL-E3)
Nominal output	30 seconds (Do not rotate continuously for longer periods.)
Direction of rotation	Clockwise as viewed from pinion side

- (1) Solenoid Switch
- (2) Plunger
- (3) Spring
- (4) Shift Lever
- (5) Brush
- (6) Commutator
- (7) Armature
- (8) Field Coil
- (9) Overrunning Clutch

9Y1210571ENM0010US0

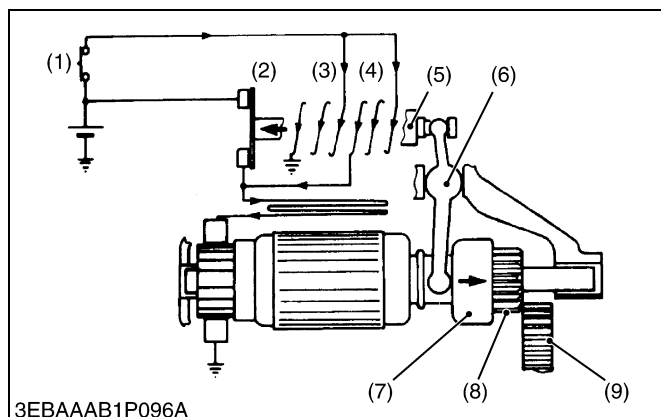

Operation of Starter

[When key switch is turned to "START" position]

The contacts of key switch (1) close and the holding coil (3) is connected to the battery to pull the plunger (5).

The pull-in coil (4) and the starting motor are also connected to the battery.

The pinion (8) is pushed against the ring gear (9) with the overrunning clutch (7) by the shift lever (6) and the magnetic switch is closed.

[When the solenoid switch is closed]

The current from the battery flows through the solenoid switch (2) to the starting motor.

The pinion (8), which is pushed against the ring gear (9) and rotated along the spline, meshes with the ring gear to crank the engine.

The engine starts and increases its speed.

While the pinion spins faster than the armature, the overrunning clutch (7) allows the pinion to spin independently from the armature.

The pull-in coil (4) is short-circuited through the solenoid switch (2) and the key switch (1).

[When the key switch is released]

The current from the battery flows to the holding coil (3) through the pull-in coil (4) to diminish the magnetism between them.

The plunger (5) is pushed by the spring to pull in the pinion.

- (1) Key Switch
- (2) Solenoid Switch
- (3) Holding Coil
- (4) Pull-in Coil
- (5) Plunger
- (6) Shift Lever
- (7) Overrunning Clutch
- (8) Pinion
- (9) Ring Gear

9Y1210318ENM0044US0

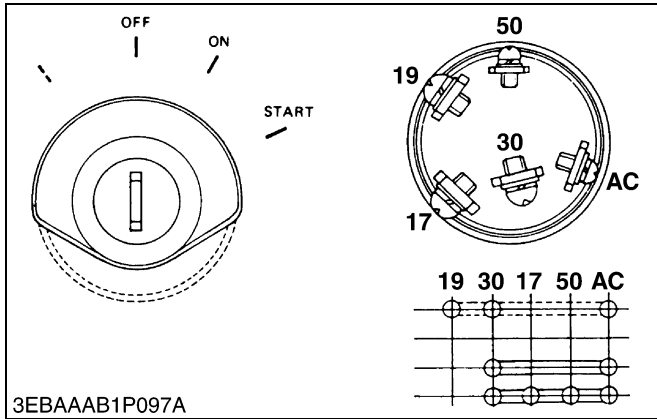

Key Switch

The key switch has 4 positions. The terminal "30" is connected to the battery.

It is released at the "START" position and returns to the "ON" position.

[START]

When the key is turned to the "START" position, through the "ON" position the current supplied to the starter to regulator, oil lamp and accessory.

50 to starter

30 from battery

AC to regulator, oil lamp and accessory

[ON]

Only the terminal "AC" is connected to the battery. At any position of the key except the "OFF" position, the terminal "AC" is connected to the "30" terminal.

30 from battery

AC to regulator, oil lamp and accessory

9Y1210318ENM0045US0

[2] CHARGING SYSTEM

(1) WG752-G/GL-E3

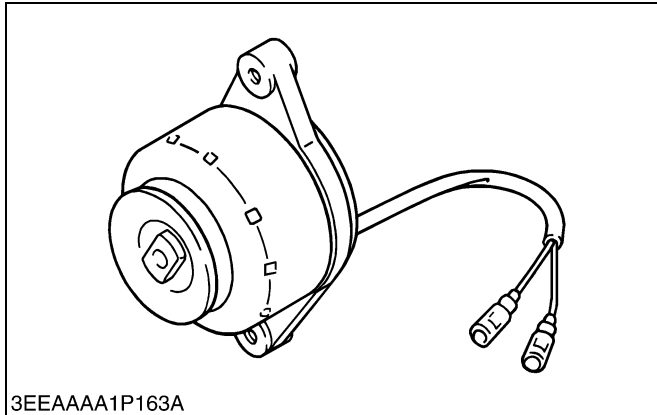

Dynamo

This dynamo is an 8-8 pole rotating magnet type generator. It is simple in construction, consisting of a stator and rotor. The rotor is made up of eight permanent magnet pole pieces assembled on a shaft and rotates on the center of the stator around which eight electromagnetic coils are provided for. This dynamo produces higher voltage in slow speed rotation, and charges electric current to the battery during engine idling.

9Y1210571ENM0017US0

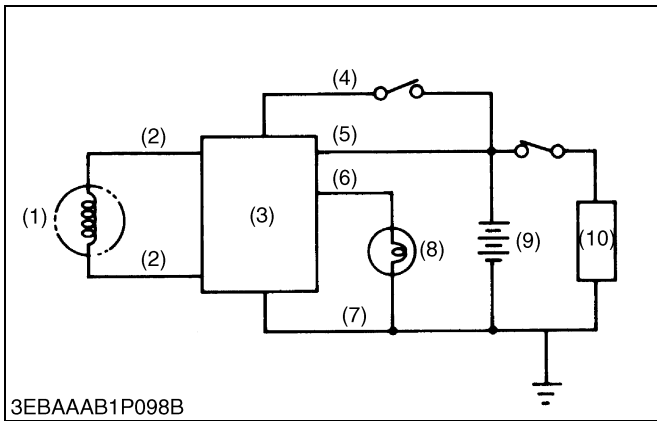

Regulator

The regulator performs rectification and voltage regulation. The regulator converts AC into DC which flows through the power consuming circuits and the battery, and also charges the battery. If however, the battery voltage exceeds a certain level. The DC current is cut off from the charging circuit to prevent overcharging.

Model	RX5104
Part No.	PN201-68562
Weight	Approx. 190 g
Regulated voltage	14 to 15 V
Battery to be used	12 V, 21~100 AH
Charge indication lamp	12 V, 3.4 W
Dynamo to be used	Under 100 V of peak value of no-load voltage Under 16 A of output current

- (1) Dynamo
- (2) Blue Lead Wire
- (3) Regulator
- (4) Yellow Lead Wire
- (5) Red Lead Wire
- (6) Overrunning Clutch
- (7) Black Lead Wire
- (8) Charge Lamp
- (9) Battery
- (10) Load

9Y1210571ENM0012US0

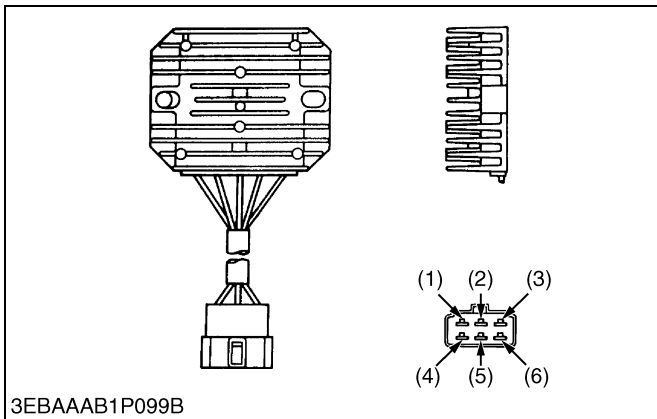

Features

1. This small-sized regulator can control large output current because charging current is supplied and stopped by thyristor (series system).
2. Built-in AC diode generation detecting circuit permits a charge indication lamp (12 V, 3.4 W) to be easily connected.
3. Protection diode protects regulator when battery is wrongly connected.

- (1) Blue Lead Wire
- (2) Black Lead Wire
- (3) Blue Lead Wire
- (4) Green Lead Wire
- (5) Yellow Lead Wire
- (6) Red Lead Wire

9Y1210318ENM0048US0

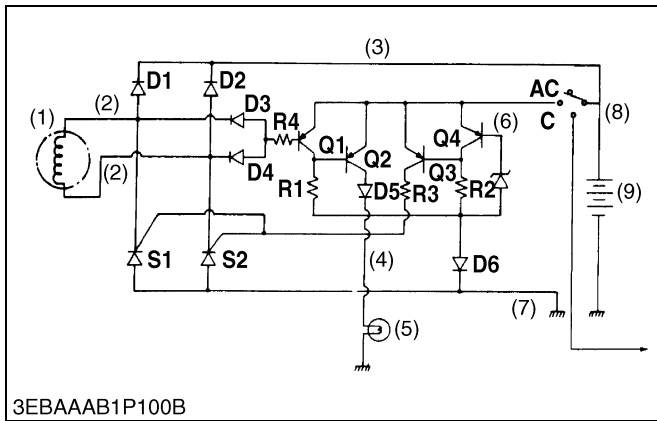

Charging Mechanism

The charging mechanism is described in four sections.

1. When key switch is "ON".
2. At starting
3. In charging
4. Over-charge protection

- (1) GEN : Magnet type AC generator
- (2) Blue : GEN connecting terminal
- (3) Red : BATT + connecting terminal
- (4) Green : LAMP connecting terminal
- (5) LAMP : Charge indication lamp (not included in the basic engine)
- (6) Yellow : BATT voltage test terminal
- (7) Black : BATT - connecting terminal
- (8) KEY SW : Key switch
- (9) BATT : Battery (not included in the basic engine)

- S1, S2 : Output control / rectification thyristor (SCR)**
- D1, D2 : Output rectifying diode**
- D3, D4 : GEN generation detecting diode**
- D5, D6 : Protection diode for wrong connecting of BATT**
- Z1 : BATT terminal voltage setting diode**
- Q1 : GEN generation detecting transistor**
- Q2 : LAMP on / off transistor**
- Q3 : Gate current control transistor**
- Q4 : BATT voltage detecting transistor**

9Y1210318ENM0049US0

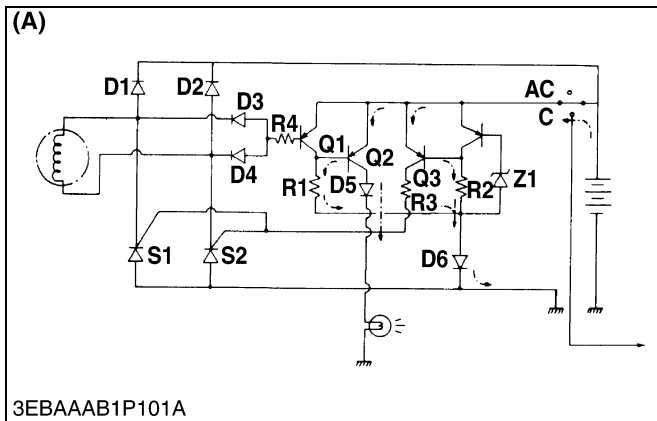

1. When Key Switch is "ON"

When the engine is at standstill with key switch set at position 1, the circuit functions to light LAMP, as shown in figure (A). With key switch at position 1, current flows to base of Q2 through the route of BATT → emitter / base of Q2 → R1 → D6 → BATT and collector of Q2 is then turned on. As a result, current also flows to LAMP through the route of BATT → emitter / collector of Q2 → D5 → LAMP → BATT lighting LAMP to indicate that charging is not carried out. At this time, through current flows to base of Q3 through the route of BATT → emitter / base of Q3 → R2 → D6 → BATT, collector of Q3 has no current because GEN is stationary.

9Y1210318ENM0050US0

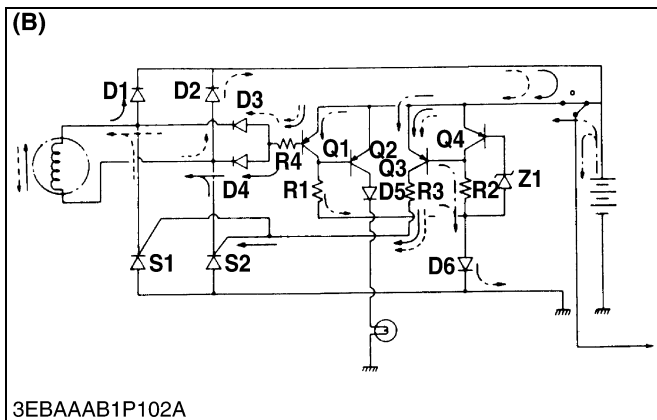

2. At Starting

When key switch is turned to position 2, coil of starter relay is energized and starter starts engine. GEN also starts generation for charging and LAMP is turned off.

In detail, with GEN starting, current flows to base of Q1 through the route of GEN → D1 → emitter / base of Q1 → R4 → D4 → GEN, or GEN → D2 → emitter / base of Q1 → R4 → D3 → GEN, and therefore current also flows through Q1, shortcircuiting emitter and base of Q2. As a result, base current of Q2 is interrupted, Q2 is turned off and accordingly current to LAMP is also interrupted.

9Y1210318ENM0051US0

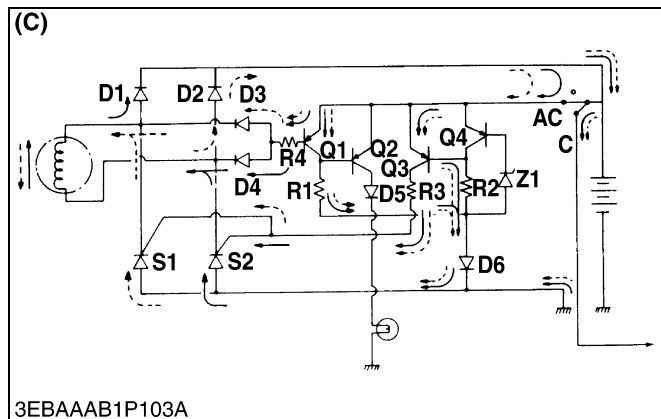

3. In Charging

Because BATT terminal voltage just after engine start is lower than setting value (14 to 15 V), or lower than zener level of Z1, current is not supplied to base of Q4 and Q4 is off, as shown in figure (B). Q3 is on with base current which flows through the route of BATT → emitter / base of Q3 → R2 → D6 → BATT, and gate current is supplied to S1 or S2 through the route of GEN → D1 → emitter / collector of Q3 → R3 → gate / cathode of S2 → GEN, or GEN → D2 emitter / collector of Q3 → R3 → gate / cathode of S1 → GEN.

When engine speed is increased so that GEN generation voltage becomes higher than BATT terminal voltage, S1 or S2 is turned on and, as shown in figure (C), charge current is supplied to BATT through the route of GEN → D1 → BATT → anode / cathode of S2 → GEN, or GEN → D2 → BATT → anode / cathode of S1 → GEN.

After S1 or S2 is turned on, collector current of Q1 and base current of Q3 are supplied by GEN, not BATT.

When key switch is turned to position 1 after engine is started, BATT is charged, if BATT terminal voltage is lower than the setting value, or zener level of Z1.

9Y1210318ENM0052US0

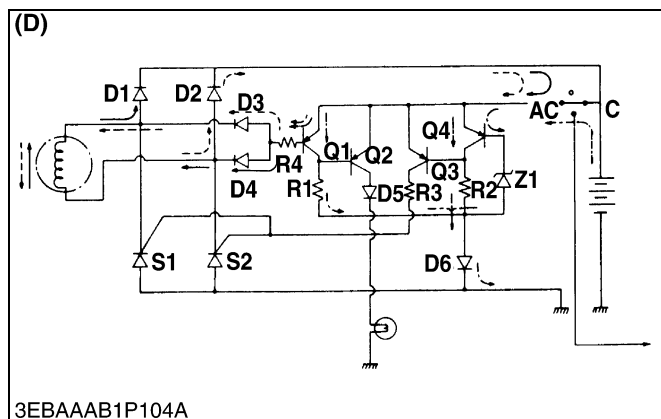

4. Over-Charge Protection

When BATT terminal voltage is higher than the setting value or zener level of Z1, BATT is not charged by the function of circuit as shown in figure (D). That is, Q4 is on with base current which flows through the route of BATT → emitter / base of Q4 → Z1 → D6 → BATT, shortcircuiting emitter and base of Q3. Therefore, Q3 is off with no base current and gate current is not supplied to S1 and S2. Consequently S1 and S2 are off and BATT is not charged.

9Y1210318ENM0053US0

(2) WG972-G/GL-E3

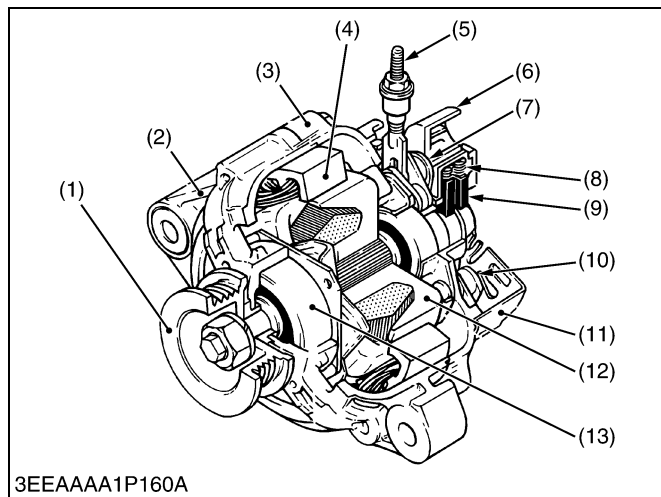

Alternator

A compact alternator with an IC regulator is used, having the following characteristics :

- Cooling performance and safety have been improved by combining the cooling fan with the rotor and incorporating the fan / rotor unit inside the alternator.
- IC regulator is fitted inside the alternator.
- The rectifier, IC regulator and similar components are easy to remove, making it easier to service the alternator.

- | | |
|---------------------|---------------------|
| (1) Pulley | (8) Spring |
| (2) Drive End Frame | (9) Brush |
| (3) Rear End Frame | (10) Rectifier |
| (4) Stator | (11) Rear End Cover |
| (5) Terminal | (12) Rotor |
| (6) Connector | (13) Bearing |
| (7) IC Regulator | |

9Y1210571ENM0028US0

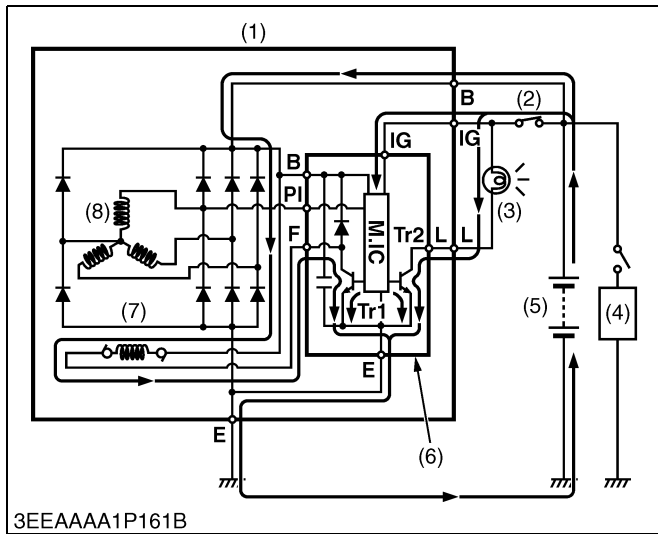

When Main Switch Is Turned to ON Position

As the battery voltage is added to the terminal **IG**, **M.IC** circuit detects it and makes current pour to the **Tr1**. It results to pour the initial exciting current to the rotor coil (7). (In this case, **M.IC** circuit makes current pour on and off the **Tr1** in pulse and limits the battery discharging current to small value (Approx. 0.17 A) when the main switch (2) is turned on.)

As the alternator (1) is not rotated, it doesn't generate. Therefore the voltage of terminal **PI** is zero volt. **M.IC** circuit detects it and makes current pour to the **Tr2**. It results light on the charge lamp (3).

- (1) Alternator
- (2) Main Switch
- (3) Charge Lamp
- (4) Load
- (5) Battery
- (6) IC Regulator
- (7) Rotor Coil
- (8) Stator Coil

M.IC : Monolithic IC
Tr1 : Transistor
Tr2 : Transistor

9Y1210571ENM0018US0

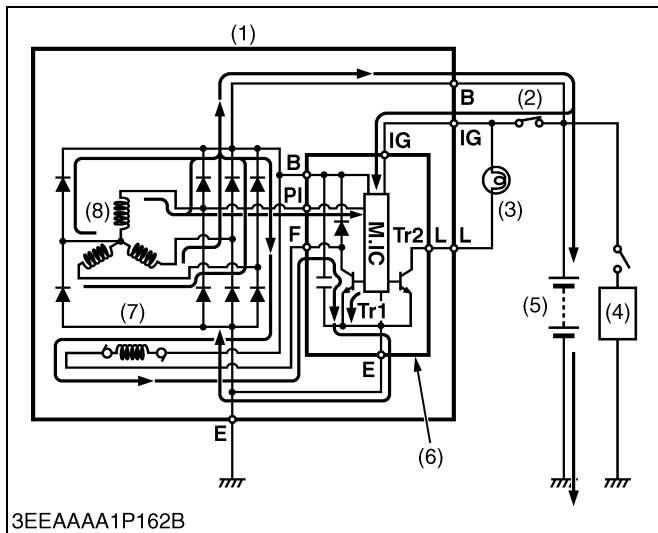

When Engine Starts

When the engine starts and the alternator (1) rotates, **M.IC** circuit makes current pour continuously to the **Tr1** instead of the uncontinuous (in pulse) current. Therefore a sufficient exciting current flows and a generated voltage rises rapidly. As a result, the current to the **Tr2** is shut and lights off the charge lamp (3).

When terminal **B** voltage rises over the battery voltage, a charged current flows to the battery (5).

When the terminal **B** voltage further rises over the regulated voltage (14.2 to 14.8 V : 25 °C, 77 °F), **M.IC** circuit shuts the current to the **Tr1**. Therefore the current to the rotor coil is shut, resulting to decrease the terminal **B** voltage.

When the terminal **B** voltage lowers below the regulated voltage, the **Tr1** turns on again and makes current pour to the rotor coil.

- (1) Alternator
- (2) Main Switch
- (3) Charge Lamp
- (4) Load
- (5) Battery
- (6) IC Regulator
- (7) Rotor Coil
- (8) Stator Coil

M.IC : Monolithic IC
Tr1 : Transistor
Tr2 : Transistor

9Y1210571ENM0019US0

[3] SOLENOID

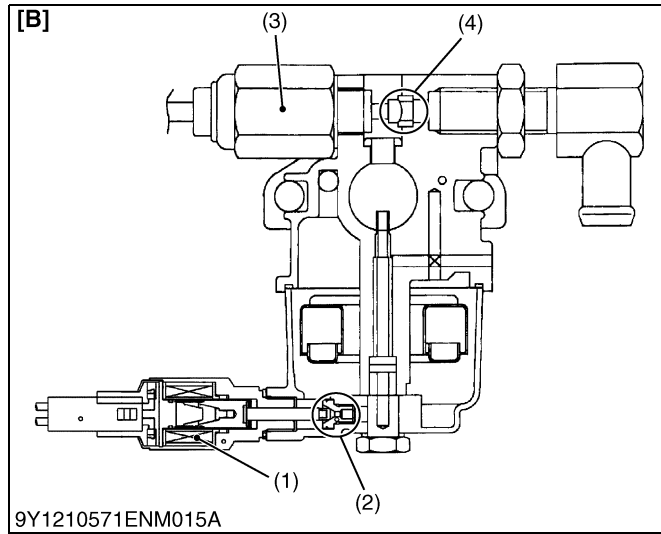
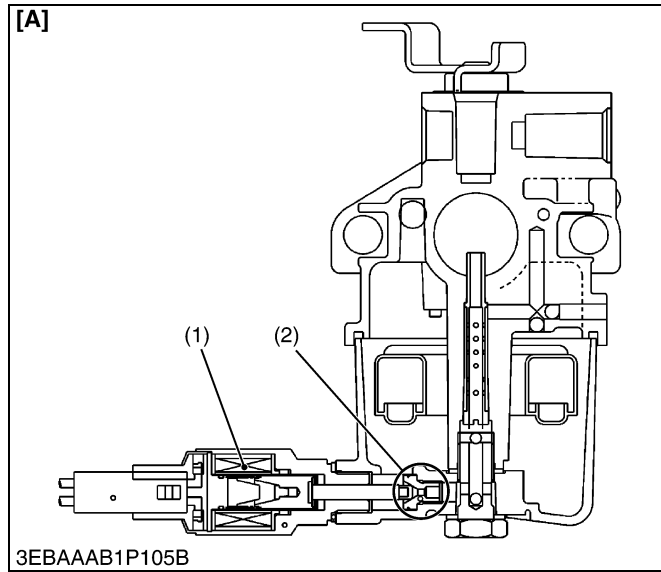

When the key switch is turned on, a current flows to the solenoid, which in turn opens the solenoid valve.

When the key switch is turned off, the solenoid valve closes, blocking the gasoline main jet (2) / LPG main jet (4).

- (1) Gasoline Solenoid Valve
- (2) Gasoline Main Jet
- (3) LPG Solenoid Valve
- (4) LPG Main Jet

[A] **WG752-G-E3, WG972-G-E3**

[B] **WG752-GL-E3,
WG972-GL-E3**

9Y1210571ENM0014US0

SERVICING

CONTENTS

1. TROUBLESHOOTING.....	1-S1
[1] FOR GENERAL.....	1-S1
[2] FOR GASOLINE FUEL.....	1-S2
[3] FOR LPG FUEL.....	1-S3
2. SERVICING SPECIFICATIONS.....	1-S4
3. TIGHTENING TORQUES.....	1-S13
[1] TIGHTENING TORQUES FOR SPECIAL USE SCREWS, BOLTS AND NUTS.....	1-S13
[2] TIGHTENING TORQUES FOR GENERAL USE SCREWS, BOLTS AND NUTS.....	1-S14
4. CHECKING, DISASSEMBLING AND SERVICING.....	1-S15
[1] CHECKING AND ADJUSTING.....	1-S15
(1) Engine Body.....	1-S15
(2) Lubricating System.....	1-S17
(3) Cooling System.....	1-S18
(4) Fuel System.....	1-S20
(5) Ignition System.....	1-S24
(6) Electrical System.....	1-S29
[2] DISASSEMBLING AND ASSEMBLING.....	1-S32
(1) Draining Coolant and Engine Oil.....	1-S32
(2) External Components.....	1-S33
(3) Cylinder Head, Valves and Oil Pan.....	1-S36
(4) Thermostat.....	1-S40
(5) Timing Gear, Camshaft and Distributor Shaft (WG752-G/GL-E3) / Gear Shaft (WG972-G/GL-E3).....	1-S40
(6) Piston and Connecting Rod.....	1-S43
(7) Crankshaft.....	1-S45
(8) Starter.....	1-S48
(9) Dynamo.....	1-S49
(10) Alternator.....	1-S50
[3] SERVICING.....	1-S51
(1) Combustion Chamber.....	1-S51
(2) Cylinder Head and Valves.....	1-S52
(3) Timing Gear and Camshaft.....	1-S57
(4) Piston and Connecting Rod.....	1-S60
(5) Crankshaft.....	1-S64
(6) Cylinder.....	1-S70
(7) Oil Pump.....	1-S71
(8) Starter.....	1-S72
(9) Alternator.....	1-S74

1. TROUBLESHOOTING

[1] FOR GENERAL

Symptom	Probable Cause	Solution	Reference Page
Engine Will Not Turn Over	Engine jammed	Check engine to find the problem and repair it	–
	Battery discharged	Charge	–
	Starter malfunctioning	Repair or replace	1-S29
	Wires disconnected	Reconnect	–
Engine Turns Over Slowly but Does Not Start	Increased resistance of moving parts	Repair or replace	–
	Excessively high viscosity engine oil at low temperature	Use specified engine oil	G-9
Engine Turns Over at Normal Speed but Does Not Start	Compression leak	Check the compression pressure and repair	1-S15
	Improper valve clearance	Adjust	1-S16
	Defective ignition coil	Replace	1-S27
	Defective spark plug	Adjust spark plug gap or replace	G-13
	Defective ignitor	Replace	1-S28
	Clogged air cleaner	Clean or replace	G-12
Rough Low-Speed Running and Idling	Defective ignition coil	Replace	1-S27
	Defective spark plug	Adjust spark plug gap or replace	G-13
	Defective ignitor	Replace	1-S28
	Incorrect governor adjustment	Adjust	1-S20
	Improper valve clearance	Adjust	1-S16
Rough High-Speed Running	Defective ignitor	Replace	1-S28
	Defective spark plug	Adjust spark plug gap or replace	G-13
	Defective ignition coil	Replace	1-S27
	Incorrect governor adjustment	Adjust	1-S20
Engine Speed Does Not Increase	Incorrect governor adjustment	Adjust	1-S20
	Defective ignitor	Replace	1-S28
	Clogged air cleaner	Clean or replace	G-12
Deficient Output	Improper intake or exhaust valve sealing	Replace	1-S54
	Incorrect governor adjustment	Adjust	1-S20
	Excessive carbon in engine	Remove carbon	G-22
	Improper valve clearance	Adjust	1-S16
	Piston ring and cylinder worn	Replace	1-S62, 1-S70
	Clogged air cleaner	Clean or replace	G-12

Symptom	Probable Cause	Solution	Reference Page
Engine Noise	Improper valve clearance	Adjust	1-S16
	Spark knock due to low-octane fuel or carbon	Use higher-octane fuel and remove carbon	–
	Rattles from loosely mounted external components	Retighten	–
Exhaust Flames	Defective ignition coil	Replace	1-S27
	Defective high tension cord	Replace	G-25
	Defective spark plug	Adjust spark plug or replace	G-13
	Wires disconnected or defective wire	Reconnect / replace	1-S28
	Bad connection of the high tension cord and spark plug	Reconnect	–

9Y1210571ENS0054US0

[2] FOR GASOLINE FUEL

Symptom	Probable Cause	Solution	Reference Page
Engine Turns Over at Normal Speed but Does Not Start	No fuel	Replenish fuel	–
	Defective fuel system	Check fuel line and carburetor and repair	–
	Over choked	Clean spark plug	–
	Flooding from carburetor	Check carburetor and repair / replace	–
Rough Low-Speed Running and Idling	Incorrect carburetor idle adjustment	Adjust	1-S20
Engine Speed Does Not Increase	Incorrect carburetor adjustment	Adjust	1-S20

9Y1210571ENS0055US0

[3] FOR LPG FUEL

Symptom	Probable Cause	Solution	Reference Page
Engine Turns Over at Normal Speed but Does Not Start	No LPG fuel	Replenish LPG fuel Check LPG tank valve Check shut off solenoid valve	–
	Defective vacuum lock system	Check vacuum hose Replace vaporizer	1-S23
	Defective throttle lever position	Set throttle lever to the low idle position	1-S20
Rough Low-Speed Running and Idling	Shortage of gas supply	Replenish LPG fuel Check shut off solenoid valve	–
	Defective idling	Replace vaporizer Draining tar from vaporizer	G-20, G-23
Defection Output	LPG density is rich	Replace vaporizer	–
	Shortage LPG	Repair or replace of fuel system Replace vaporizer	–

9Y1210571ENS0056US0

2. SERVICING SPECIFICATIONS

ENGINE BODY

Item		Factory Specification	Allowable Limit
Valve Clearance (Cold)		0.145 to 0.185 mm 0.00571 to 0.00728 in.	–
Compression Pressure	–	1.27 MPa 13.0 kgf/cm ² 185 psi	0.88 MPa 9.0 kgf/cm ² 130 psi
	Variance Among Cylinder	–	10 % or less
Top Clearance [WG752-G/GL-E3]		1.45 to 1.75 mm 0.0571 to 0.0688 in.	–
[WG972-G/GL-E3]		1.35 to 1.65 mm 0.0532 to 0.0649 in.	–
Cylinder Head Surface	Flatness	–	0.05 mm 0.002 in.
Valve Recessing (Intake and Exhaust)		–0.10 to 0.10 mm –0.0039 to 0.0039 in.	0.30 mm 0.012 in.
Valve Stem to Valve Guide	Clearance	0.030 to 0.057 mm 0.0012 to 0.0022 in.	0.10 mm 0.0039 in.
	• Valve Stem O.D.	5.968 to 5.980 mm 0.2350 to 0.2354 in.	–
	• Valve Guide I.D.	6.010 to 6.025 mm 0.2367 to 0.2372 in.	–
Valve Face	Angle	0.79 rad 45 °	–
Valve Seat	Angle	0.79 rad 45 °	–
	Width	2.12 mm 0.0835 in.	–
Valve Timing (Intake Valve)	Open	0.35 rad 20 ° before T.D.C.	–
	Close	0.79 rad 45 ° after B.D.C.	–
Valve Timing (Exhaust Valve)	Open	0.87 rad 50 ° before B.D.C.	–
	Close	0.26 rad 15 ° after T.D.C.	–

Item		Factory Specification	Allowable Limit
Valve Spring	Free Length	31.3 to 31.8 mm 1.24 to 1.25 in.	28.4 mm 1.12 in.
	Tilt	–	1.2 mm 0.047 in.
	Setting Load / Setting Length	65 N / 27.0 mm 6.6 kgf / 27.0 mm 15 lbf / 1.06 in.	55 N / 27.0 mm 5.6 kgf / 27.0 mm 12 lbf / 1.06 in.
Rocker Arm Shaft to Rocker Arm	Oil Clearance	0.016 to 0.045 mm 0.00063 to 0.0017 in.	0.15 mm 0.0059 in.
• Rocker Arm Shaft	O.D.	10.473 to 10.484 mm 0.41233 to 0.41275 in.	–
• Rocker Arm	I.D.	10.500 to 10.518 mm 0.41339 to 0.41409 in.	–
Push Rod	Alignment	–	0.25 mm 0.0098 in.
Tappet to Tappet Guide Bore	Oil Clearance	0.016 to 0.052 mm 0.00063 to 0.0020 in.	0.10 mm 0.0039 in.
• Tappet	O.D.	17.966 to 17.984 mm 0.70733 to 0.70803 in.	–
• Tappet Guide Bore	I.D.	18.000 to 18.018 mm 0.70867 to 0.70937 in.	–
Timing Gear	Backlash	0.0430 to 0.124 mm 0.00170 to 0.00488 in.	0.15 mm 0.0059 in.
• Crank Gear to Idle Gear	Backlash	0.0470 to 0.123 mm 0.00185 to 0.00484 in.	0.15 mm 0.0059 in.
• Idle Gear to Cam Gear	Backlash	0.0410 to 0.124 mm 0.00162 to 0.00488 in.	0.15 mm 0.0059 in.
• Idle Gear to Injection Pump Gear	Backlash	0.0410 to 0.123 mm 0.00162 to 0.00484 in.	0.15 mm 0.0059 in.
• Crank Gear to Oil Pump Drive Gear	Backlash	0.0410 to 0.123 mm 0.00162 to 0.00484 in.	0.15 mm 0.0059 in.
Idle Gear [WG752-G/GL-E3]	Side Clearance	0.20 to 0.46 mm 0.0079 to 0.018 in.	0.60 mm 0.024 in.
[WG972-G/GL-E3]	Side Clearance	0.20 to 0.51 mm 0.0079 to 0.020 in.	0.80 mm 0.031 in.
Camshaft	Side Clearance	0.15 to 0.31 mm 0.0059 to 0.012 in.	0.50 mm 0.020 in.
	Alignment	–	0.01 mm 0.0004 in.
	Cam Height (Intake and Exhaust)	26.88 mm 1.058 in.	26.83 mm 1.056 in.

Item		Factory Specification	Allowable Limit	
Camshaft Journal to Cylinder Block Bore	Oil Clearance	0.050 to 0.091 mm 0.0020 to 0.0035 in.	0.15 mm 0.0059 in.	
	• Camshaft Journal	O.D.	32.934 to 32.950 mm 1.2967 to 1.2972 in.	–
	• Cylinder Block Bore	I.D.	33.000 to 33.025 mm 1.2993 to 1.3001 in.	–
Idle Gear Shaft to Idle Gear Bushing	Oil Clearance	0.020 to 0.084 mm 0.00079 to 0.0033 in.	0.10 mm 0.0039 in.	
	• Idle Gear Shaft	O.D.	19.967 to 19.980 mm 0.78611 to 0.78661 in.	–
	• Idle Gear Bushing	I.D.	20.000 to 20.051 mm 0.78741 to 0.78940 in.	–
Piston Pin Bore [WG752-G/GL-E3]	I.D.	18.000 to 18.011 mm 0.70867 to 0.70909 in.	18.05 mm 0.7106 in.	
	[WG972-G/GL-E3]	I.D.	20.000 to 20.013 mm 0.78741 to 0.78791 in.	20.05 mm 0.7894 in.
Piston Pin to Small End Bushing [WG752-G/GL-E3]	Oil Clearance	0.02 to 0.04 mm 0.0008 to 0.001 in.	0.10 mm 0.0039 in.	
	• Piston Pin	O.D.	18.000 to 18.005 mm 0.70867 to 0.70885 in.	–
	• Small End Bushing	I.D.	18.025 to 18.040 mm 0.70965 to 0.71023 in.	–
	[WG972-G/GL-E3]	Oil Clearance	0.012 to 0.038 mm 0.00048 to 0.0014 in.	0.10 mm 0.0039 in.
	• Piston Pin	O.D.	20.002 to 20.013 mm 0.78748 to 0.78791 in.	–
	• Small End Bushing	I.D.	20.025 to 20.040 mm 0.78839 to 0.78897 in.	–
Piston Pin to Small End Bushing (Spare Parts) [WG752-G/GL-E3]	Oil Clearance	0.02 to 0.04 mm 0.0008 to 0.001 in.	0.10 mm 0.0039 in.	
	• Small End Bushing	I.D.	18.025 to 18.040 mm 0.70965 to 0.71023 in.	–
	[WG972-G/GL-E3]	Oil Clearance	0.013 to 0.075 mm 0.00052 to 0.0029 in.	0.15 mm 0.0059 in.
	• Small End Bushing	I.D.	20.026 to 20.077 mm 0.78843 to 0.79043 in.	–

Item		Factory Specification	Allowable Limit
Piston Ring Gap [WG752-G/GL-E3] [WG972-G/GL-E3]	Top Ring	0.15 to 0.35 mm 0.0059 to 0.013 in.	0.15 mm 0.0059 in.
	Second Ring	0.15 to 0.35 mm 0.0059 to 0.013 in.	–
	Oil Ring (Upper and lower rail)	0.25 to 0.45 mm 0.0099 to 0.017 in.	–
	Top Ring	0.15 to 0.35 mm 0.0059 to 0.013 in.	1.25 mm 0.0492 in.
	Second Ring	0.30 to 0.45 mm 0.012 to 0.017 in.	1.25 mm 0.0492 in.
	Oil Ring (Upper and lower rail)	0.20 to 0.70 mm 0.0079 to 0.027 in.	1.25 mm 0.0492 in.
Piston Ring to Piston Ring Groove [WG752-G/GL-E3] [WG972-G/GL-E3]	Top Ring (Clearance)	0.04 to 0.08 mm 0.002 to 0.003 in.	0.15 mm 0.0059 in.
	Second Ring (Clearance)	0.04 to 0.08 mm 0.002 to 0.003 in.	–
	Oil Ring (Clearance)	0.060 to 0.15 mm 0.0024 to 0.0059 in.	–
	Top Ring (Clearance)	0.080 to 0.12 mm 0.0032 to 0.0047 in.	0.15 mm 0.0059 in.
	Second Ring (Clearance)	0.065 to 0.10 mm 0.0026 to 0.0039 in.	0.15 mm 0.0059 in.
	Oil Ring (Clearance)	0.060 to 0.15 mm 0.0024 to 0.0059 in.	0.20 mm 0.0079 in.
Connecting Rod	Alignment	–	0.05 mm 0.002 in.
Crankshaft	Side Clearance	0.15 to 0.31 mm 0.0059 to 0.012 in.	0.50 mm 0.020 in.
	Alignment	–	0.02 mm 0.0008 in.
Crankpin to Crankpin Bearing	Oil Clearance	0.020 to 0.051 mm 0.00079 to 0.0020 in.	0.15 mm 0.0059 in.
	• Crankpin O.D.	33.959 to 33.975 mm 1.3370 to 1.3375 in.	–
	• Crankpin Bearing I.D.	33.995 to 34.010 mm 1.3384 to 1.3389 in.	–

Item		Factory Specification	Allowable Limit	
Crankshaft Journal to Crankshaft Bearing 1 [WG752-G/GL-E3] • Crankshaft Journal • Crankshaft Bearing 1	Oil Clearance	0.0340 to 0.106 mm 0.00134 to 0.00417 in.	0.20 mm 0.0079 in.	
	O.D.	39.934 to 39.950 mm 1.5722 to 1.5728 in.	–	
	I.D.	39.984 to 40.040 mm 1.5742 to 1.5763 in.	–	
	[WG972-G/GL-E3] • Crankshaft Journal • Crankshaft Bearing 1	Oil Clearance	0.0340 to 0.106 mm 0.00134 to 0.00417 in.	0.20 mm 0.0079 in.
		O.D.	43.934 to 43.950 mm 1.7297 to 1.7303 in.	–
		I.D.	43.984 to 44.040 mm 1.7317 to 1.7338 in.	–
Crankshaft Journal to Crankshaft Bearing 2 (Flywheel Side) • Crankshaft Journal • Crankshaft Bearing 2	Oil Clearance	0.028 to 0.059 mm 0.0011 to 0.0023 in.	0.20 mm 0.0079 in.	
	O.D.	43.934 to 43.950 mm 1.7297 to 1.7303 in.	–	
	I.D.	43.978 to 43.993 mm 1.7315 to 1.7320 in.	–	
Crankshaft Journal to Crankshaft Bearing 3 (Intermediate) [WG752-G/GL-E3] • Crankshaft Journal • Crankshaft Bearing 3 [WG972-G/GL-E3] • Crankshaft Journal • Crankshaft Bearing 3	Oil Clearance	0.028 to 0.059 mm 0.0011 to 0.0023 in.	0.20 mm 0.0079 in.	
	O.D.	39.934 to 39.950 mm 1.5722 to 1.5728 in.	–	
	I.D.	39.978 to 39.993 mm 1.5740 to 1.5745 in.	–	
	Oil Clearance	0.028 to 0.059 mm 0.0011 to 0.0023 in.	0.20 mm 0.0079 in.	
	O.D.	43.934 to 43.950 mm 1.7297 to 1.7303 in.	–	
	I.D.	43.978 to 43.993 mm 1.7315 to 1.7320 in.	–	
	Cylinder Liner [Standard] [WG752-G/GL-E3]	I.D.	68.000 to 68.019 mm 2.6772 to 2.6779 in.	68.169 mm 2.6838 in.
		[WG972-G/GL-E3]	I.D.	74.500 to 74.519 mm 2.9331 to 2.9338 in.

Item		Factory Specification	Allowable Limit
Cylinder Liner [Oversize : 0.5 mm (0.02 in.)] [WG752-G/GL-E3]	I.D.	68.500 to 68.519 mm 2.6969 to 2.6975 in.	68.669 mm 2.7035 in.
	[WG972-G/GL-E3]	I.D.	75.000 to 75.019 mm 2.9528 to 2.9535 in.

LUBRICATING SYSTEM

Item		Factory Specification	Allowable Limit
Engine Oil Pressure [WG752-G/GL-E3] [WG972-G/GL-E3]	At Idle Speed	More than 70 kPa 0.7 kgf/cm ² 10 psi	—
	At Rated Speed	200 to 440 kPa 2.0 to 4.5 kgf/cm ² 29 to 64 psi	190 kPa 1.9 kgf/cm ² 27 psi
	At Idle Speed	More than 50 kPa 0.5 kgf/cm ² 7 psi	—
	At Rated Speed	200 to 440 kPa 2.0 to 4.5 kgf/cm ² 29 to 64 psi	150 kPa 1.5 kgf/cm ² 21 psi
Inner Rotor to Outer Rotor	Clearance	0.030 to 0.14 mm 0.0012 to 0.0055 in.	—
Outer Rotor to Pump Body	Clearance	0.070 to 0.15 mm 0.0028 to 0.0059 in.	—
Inner Rotor to Cover	Clearance	0.0750 to 0.135 mm 0.00296 to 0.00531 in.	—

COOLING SYSTEM

Item		Factory Specification	Allowable Limit
Fan Belt	Tension	7.0 to 9.0 mm / 98 N 0.28 to 0.35 in. / 98 N (10 kgf, 22 lbf)	—
Thermostat [WG752-G/GL-E3] [WG972-G/GL-E3]	Valve Opening Temperature (At Beginning)	80.5 to 83.5 °C 176.9 to 182.3 °F	—
	Valve Opening Temperature (Opened Completely)	95 °C 203 °F	—
	Valve Opening Temperature (At Beginning)	69.5 to 72.5 °C 157.1 to 162.5 °F	—
	Valve Opening Temperature (Opened Completely)	85 °C 185 °F	—
Radiator Cap	Pressure Falling Time	More than 10 seconds for pressure fall from 90 → 60 kPa 0.9 → 0.6 kgf/cm ² 10 → 9 psi	—
Radiator	Weak Leakage Test Pressure	No leak at specified pressure	—

FUEL SYSTEM

Item	Factory Specification	Allowable Limit
Engine Speed		
• Lo - idling speed	1500 min ⁻¹ (rpm) (1400 to 1600 min (rpm))	—
• Hi - idling speed	3850 min ⁻¹ (rpm) (3850 to 3950 min ⁻¹ (rpm))	—

IGNITION SYSTEM

Item	Factory Specification	Allowable Limit	
Ignition Timing [WG752-G/GL-E3]	0.31 rad (18°) B.T.D.C.	—	
[WG972-G/GL-E3]	0.34 to 0.40 rad (19 to 23°) B.T.D.C.	—	
Pick-up Sensor [WG972-G/GL-E3]	Resistance	1.85 to 2.45 kΩ at 20 °C (68 °F)	—
Spark Plug [WG752-G/GL-E3] (NGK : BKR4E-11)	Plug Gap	1.0 to 1.1 mm 0.040 to 0.043 in.	—
[WG972-G/GL-E3] (NGK : BKR4E)	Plug Gap	0.60 to 0.70 mm 0.024 to 0.027 in.	—
Resistance of Ignition Coil [WG752-G/GL-E3]	Primary (+) - (-)	1.33 to 1.63 Ω at 20 °C (68 °F)	—
	Secondary Side (Primary (+) - Plug Cap)	10.7 to 14.5 kΩ at 20 °C (68 °F)	—
[WG972-G/GL-E3]	Primary (+) - (-)	1.87 to 2.53 Ω at 20 °C (68 °F)	—
	Secondary Side (Primary (+) - Plug Cap)	10.4 to 15.6 kΩ at 20 °C (68 °F)	—
Distributor [WG752-G/GL-E3]	Air Gap	0.2 to 0.4 mm 0.008 to 0.01 in.	—
High Tension Cord #1 [WG752-G/GL-E3]	Resistance	2.8 to 4.8 Ω at 20 °C (68 °F)	—
High Tension Cord #2 [WG752-G/GL-E3]	Resistance	3.4 to 5.8 Ω at 20 °C (68 °F)	—
High Tension Cord #3 [WG752-G/GL-E3]	Resistance	3.6 to 6.1 Ω at 20 °C (68 °F)	—
Center Cord [WG752-G/GL-E3]	Resistance	3.1 to 5.2 Ω at 20 °C (68 °F)	—

ELECTRICAL SYSTEM

Item		Factory Specification	Allowable Limit	
Starter [WG752-G/GL-E3] [WG972-G/GL-E3]	Commutator (O.D.)	32.0 mm 1.26 in.	31.0 mm 1.22 in.	
	Difference (O.D.)	Less than 0.05 mm 0.002 in.	0.4 mm 0.02 in.	
	Mica (Undercut)	0.5 to 0.8 mm 0.02 to 0.03 in.	0.4 mm 0.02 in.	
	Brush (Length)	17.0 mm 0.669 in.	11.5 mm 0.453 in.	
	Commutator (O.D.)	28.0 mm 1.10 in.	27.0 mm 1.06 in.	
	Difference (O.D.)	Less than 0.05 mm 0.002 in.	0.4 mm 0.02 in.	
	Mica (Undercut)	0.45 to 0.75 mm 0.018 to 0.029 in.	0.2 mm 0.008 in.	
	Brush (Length)	14.0 mm 0.551 in.	11.1 mm 0.437 in.	
	Dynamo	No-load Voltage	AC 20 V or more at 5200 min ⁻¹ (rpm)	–
	Regulator	Regulating Voltage	14 to 15 V	–
Alternator	No-load Voltage	14.2 V to 14.8 V at 5000 min ⁻¹ (rpm), 25 °C (77 °F)	–	
	Stator (Resistance)	Less than 1.0 Ω	–	
	Rotor (Resistance)	2.9 Ω	–	
	Slip Ring (O.D.)	14.4 mm 0.567 in.	14.0 mm 0.551 in.	
	Brush (Length)	10.5 mm 0.413 in.	8.4 mm 0.33 in.	
Gasoline Cut Off Solenoid [WG752-G/GL-E3, WG972-G/GL-E3]	Resistance	38 Ω at 20 °C (68 °F)	–	
LPG Cut Off Solenoid [WG752-GL-E3, WG972-GL-E3]	Resistance	28 Ω at 20 °C (68 °F)	–	

9Y1210571ENS0036US0

3. TIGHTENING TORQUES

Screws, bolts and nuts must be tightened to the specified torque using a torque wrench, several screws, bolts and nuts such as those used on the cylinder head must be tightened in proper sequence and the proper torque.

9Y1210318ENS0009US0

[1] TIGHTENING TORQUES FOR SPECIAL USE SCREWS, BOLTS AND NUTS

■ NOTE

- For "*" marked screws, bolts and nuts on the table, apply engine oil to their threads and seats before tightening.
- The letter "M" in Size x Pitch means that the screw, bolt or nut dimension stands for metric. The size is the nominal outside diameter in mm of the threads. The pitch is the nominal distance in mm between two threads.





Item	Dimension x Pitch	N·m	kgf·m	lbf·ft
*Cylinder head cover cap nut [WG752-G/GL-E3]	–	4.0 to 5.8	0.40 to 0.60	2.9 to 4.3
*Cylinder head cover screw [WG972-G/GL-E3]	M6 x 1.0	9.81 to 11.2	1.00 to 1.15	7.24 to 8.31
*Rocker arm bracket nut [WG752-G/GL-E3]	–	9.81 to 11.2	1.00 to 1.15	7.24 to 8.31
*Rocker arm bracket screw [WG972-G/GL-E3]	M6 x 1.0	12 to 14	1.2 to 1.5	8.7 to 10
*Cylinder head screw [WG752-G/GL-E3]	–	38 to 42	3.8 to 4.3	28 to 31
*Cylinder head screw [WG972-G/GL-E3]	M8 x 1.25	40 to 44	4.0 to 4.5	29 to 32
*Fan drive pulley screw	M12 x 1.5	118 to 127	12.0 to 13.0	86.8 to 94.0
*Idle gear shaft mounting screw	M6 x 1.0	9.81 to 11.2	1.00 to 1.15	7.24 to 8.31
*Connecting rod screw	M7 x 0.75	27 to 30	2.7 to 3.1	20 to 22
*Flywheel screw	M10 x 1.25	54 to 58	5.5 to 6.0	40 to 43
Bearing case cover mounting screw	M6 x 1.0	9.81 to 11.2	1.00 to 1.15	7.24 to 8.31
*Main bearing case screw 2	M7 x 1.0	27 to 30	2.7 to 3.1	20 to 22
*Main bearing case screw 1	M6 x 1.0	13 to 15	1.3 to 1.6	9.4 to 11
Oil pressure switch	PT 1/8	15 to 19	1.5 to 2.0	11 to 14
Spark plug	M14 x 1.25	20 to 24	2.0 to 2.5	15 to 18
Drain plug	M12 x 1.25	33 to 37	3.3 to 3.8	24 to 27
Carburetor mounting nut	M8 x 1.25	24 to 27	2.4 to 2.8	18 to 20
Joint for LPG hose of vaporizer (local arrangement) [WG752-GL-E3] [WG972-GL-E3]	PT - 1/4	20 to 39	2.0 to 4.0	15 to 28
Joint for vapor hose of vaporizer [WG752-GL-E3] [WG972-GL-E3]	PT - 3/8	30 to 58	3.0 to 6.0	22 to 43
Joint for coolant hose of vaporizer [WG752-GL-E3] [WG972-GL-E3]	PT - 3/8	30 to 58	3.0 to 6.0	22 to 43
Governor lever nut	M6 x 1.0	9.81 to 11.2	1.00 to 1.15	7.24 to 8.31
Starter B terminal nut	–	9.81 to 11.7	1.00 to 1.20	7.24 to 8.67

Item	Dimension × Pitch	N·m	kgf·m	lbf·ft
Dynamo's pulley nut	–	39.2 to 44.1	4.00 to 4.49	29.0 to 32.5
Alternator's pulley nut	–	58.4 to 78.9	5.95 to 8.05	43.1 to 58.2
Gasoline cut off solenoid	–	7.9 to 11	0.80 to 1.2	5.8 to 8.6
LPG cut off solenoid	–	11.8 to 26.4	1.20 to 2.70	8.68 to 19.5
Main jet	–	0.98 to 2.8	0.10 to 0.29	0.73 to 2.0
Pilot jet	–	0.98 to 3.9	0.10 to 0.40	0.73 to 2.8
Exhaust manifold mounting screw/nut	–	9.81 to 11.2	1.00 to 1.15	7.24 to 8.31
Catalytic Muffler mounting nut	–	23.5 to 27.5	2.40 to 2.80	17.4 to 20.2
Catalytic converter mounting nut	–	23.5 to 27.5	2.40 to 2.80	17.4 to 20.2

9Y1210571ENS0001US0

[2] TIGHTENING TORQUES FOR GENERAL USE SCREWS, BOLTS AND NUTS

If the tightening torque is not specified, refer to the table below for the none specified torques values.

Indication on top of bolt	 4 No-grade or 4T			 7 7T		
Indication on top of nut	  No-grade or 4T					
Unit	N·m	kgf·m	lbf·ft	N·m	kgf·m	lbf·ft
M6	7.9 to 9.3	0.80 to 0.95	5.8 to 6.8	9.81 to 11.2	1.00 to 1.15	7.24 to 8.31
M8	18 to 20	1.8 to 2.1	13 to 15	24 to 27	2.4 to 2.8	18 to 20
M10	40 to 45	4.0 to 4.6	29 to 33	49 to 55	5.0 to 5.7	37 to 41
M12	63 to 72	6.4 to 7.4	47 to 53	78 to 90	7.9 to 9.2	58 to 66

M00000003ENS0013US1

4. CHECKING, DISASSEMBLING AND SERVICING

[1] CHECKING AND ADJUSTING

(1) Engine Body

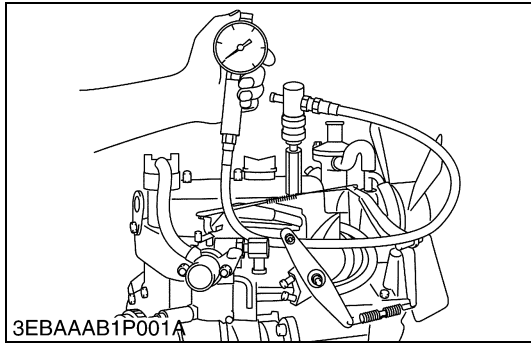

Compression Pressure

1. Run the engine until it is warmed up.
2. Stop the engine.
3. Remove the air cleaner, the muffler/converter and all spark plugs.
4. Set a compression tester with the adaptor to the spark plug hole.
5. Run the engine with the starter for 5 to 10 seconds keeping throttle valve fully open and read the maximum compression pressure.
6. Repeat steps 4 and 5 for each cylinder.
7. If the measurement is below the allowable limit, apply a small amount of oil to the cylinder wall through the spark plug hole and measure the compression pressure again.
8. If the compression pressure is still less than the allowable limit, check the top clearance, valve clearance and cylinder head.
9. If the compression pressure increases after applying oil, check the cylinder wall and piston rings.

■ NOTE

- Check the compression pressure with the specified valve clearance.
- Always use a fully charged battery for performing this test.
- Variances in cylinder compression values should be under 10 %.
- Replace the muffler/converter gasket with a new one

Compression pressure	Factory specification	1.27 MPa 13.0 kgf/cm ² 185 psi
	Allowable limit	0.88 MPa 9.0 kgf/cm ² 130 psi

9Y1210318ENS0013US0

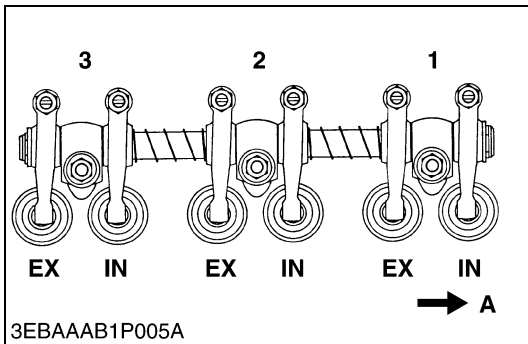
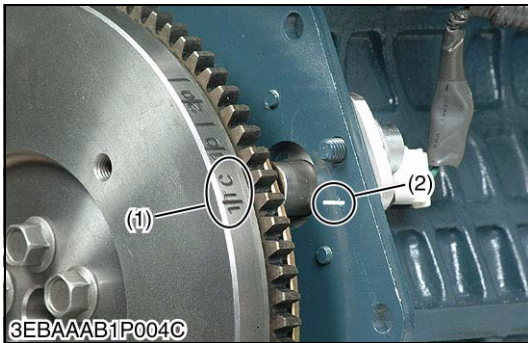
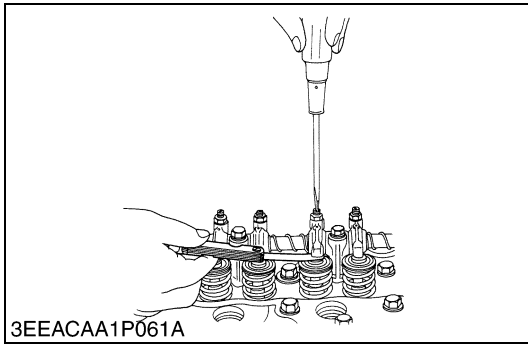

Adjusting the Valve Clearance

■ **IMPORTANT**

- The valve clearance must be checked and adjusted when engine is cold.

1. Remove the cylinder head cover and the spark plugs.
2. Align the "1TC" mark (1) on the flywheel and alignment mark (2) on the rear end plate so that the No. 1 piston comes to the compression top dead center.
3. Check the following valve clearance marked with "★" using a feeler gauge.
4. If the clearance is not within the factory specifications, adjust with the adjusting screw.
5. Then turn the flywheel 6.28 rad (360 °), and align the "1TC" mark (1) on the flywheel and alignment mark (2) on the rear end plate so that the No. 1 piston comes to the overlap position.
6. Check the following valve clearance marked with "☆" using a feeler gauge.
7. If the clearance is not within the factory specifications, adjust with the adjusting screw.

Adjustable Cylinder Location of Piston	Valve Arrangement	
	Intake valve	Exhaust valve
No. 1	★	★
No. 2	☆	★
No. 3	★	☆

★ : When No. 1 piston is at the compression top dead center position.

☆ : When No. 1 piston is at the overlap position.

Intake and exhaust valve clearance (cold)	Factory specification	0.145 to 0.185 mm 0.00571 to 0.00728 in.
---	-----------------------	---

■ **NOTE**

- The sequence of cylinder numbers is given as No. 1, No. 2 and No. 3 starting from the gear case side.
- After adjusting the valve clearance, secure the adjusting screw with the lock nut.

- (1) "1TC" Mark
(2) Alignment Mark

A : Gear Case Side

9Y1210318ENS0015US0

(2) Lubricating System

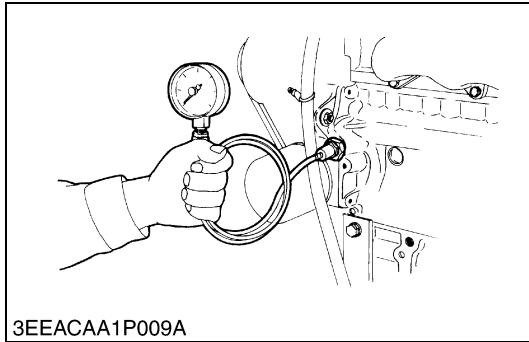

Engine Oil Pressure

1. Remove the engine oil pressure switch, and set an oil pressure tester.
2. Start the engine. After warming up, measure the oil pressure of both idling and rated speeds.
3. If the oil pressure is less than the allowable limit, check the following.
 - Engine oil insufficient
 - Oil pump defective
 - Oil strainer clogged
 - Oil filter cartridge clogged
 - Oil gallery clogged
 - Excessive oil clearance
 - Foreign matter in the relief valve

(When reassembling)

- After checking the engine oil pressure, tighten the engine oil pressure switch to the specified torque.

[WG752-G/GL-E3]

Engine oil pressure	At idle speed	Factory specification	More than 70 kPa 0.7 kgf/cm ² 10 psi
	At rated speed	Factory specification	200 to 440 kPa 2.0 to 4.5 kgf/cm ² 29 to 64 psi
		Allowable limit	190 kPa 1.9 kgf/cm ² 27 psi

[WG972-G/GL-E3]

Engine oil pressure	At idle speed	Factory specification	More than 50 kPa 0.5 kgf/cm ² 7 psi
	At rated speed	Factory specification	200 to 440 kPa 2.0 to 4.5 kgf/cm ² 29 to 64 psi
		Allowable limit	150 kPa 1.5 kgf/cm ² 21 psi

Tightening torque	Oil pressure switch	15 to 19 N·m 1.5 to 2.0 kgf·m 11 to 14 lbf·ft
-------------------	---------------------	---

9Y1210571ENS0011US0

(3) Cooling System

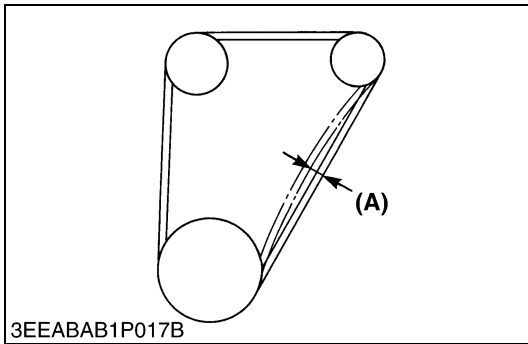

3EEABAB1P017B

Fan Belt Tension

1. Measure the deflection **(A)**, depressing the belt halfway between the fan drive pulley and alternator pulley at specified force 98 N (10 kgf, 22 lbf).
2. If the measurement is not within the factory specifications, loosen the alternator mounting screws and relocate the alternator to adjust.

Deflection (A)	Factory specification	7.0 to 9.0 mm 0.28 to 0.35 in.
-----------------------	-----------------------	-----------------------------------

(A) Deflection

9Y1210318GEG0001US0

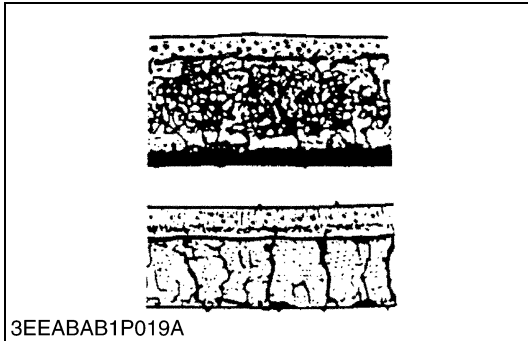

3EEABAB1P019A

Fan Belt Damage and Wear

1. Check the fan belt for damage.
2. If the fan belt is damaged, replace it.
3. Check if the fan belt is worn and sunk in the pulley groove.
4. If the fan belt is nearly worn out and deeply sunk in the pulley groove, replace it.

(A) Good

(B) Bad

9Y1210318GEG0002US0

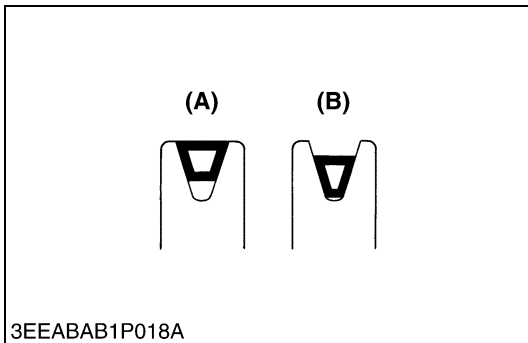

3EEABAB1P018A

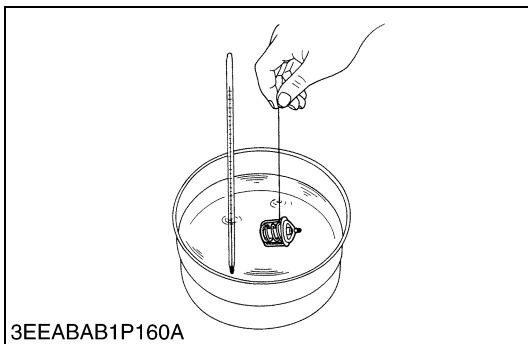

3EEABAB1P160A

Thermostat Valve Opening Temperature

1. Suspend the thermostat in the water by a string with its end inserted between the valve and seat.
2. Heating the water gradually, read the temperature when the valve opens and leaves the string.
3. Continue heating and read the temperature when the valve opens approx. 8 mm (0.3 in.).
4. If the measurement is not within the factory specifications, replace the thermostat.

[WG752-G/GL-E3]

Thermostat's valve opening temperature	Factory specification	80.5 to 83.5 °C 176.9 to 182.3 °F
Temperature at which thermostat completely opens	Factory specification	95 °C 203°F

[WG972-G/GL-E3]

Thermostat's valve opening temperature	Factory specification	69.5 to 72.5 °C 157.1 to 162.5 °F
Temperature at which thermostat completely opens	Factory specification	85 °C 185 °F

9Y1210571ENS0012US0

CAUTION

- When removing the radiator cap, wait at least ten minutes after the engine has stopped and cooled down. Otherwise, hot water may gush out, scalding nearby people.

9Y1210318ENS0018US0

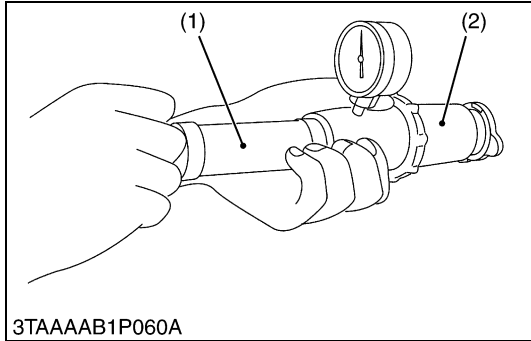

Radiator Cap Air Leakage

1. Set a radiator tester (1) and an adaptor (2) on the radiator cap.
2. Apply the specified pressure (90 kPa, 0.9 kgf/cm², 10 psi), and measure the time for the pressure to fall to 60 kPa (0.6 kgf/cm², 9 psi).
3. If the measurement is less than the factory specification, replace the radiator cap.

Pressure falling time	Factory specification	More than 10 seconds for pressure fall from 90 to 60 kPa from 0.9 to 0.6 kgf/cm ² from 10 to 9 psi
-----------------------	-----------------------	---

(1) Radiator Tester (2) Adaptor

9Y1210318ENS0019US0

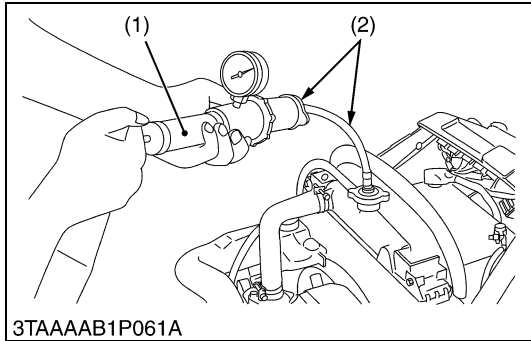

Radiator Water Leakage

1. Pour a specified amount of water into the radiator.
2. Set a radiator tester (1) and an adaptor (2) and raise the water pressure to the specified pressure.
3. Check the radiator for water leaks.
4. For water leak from the pinhole, repair with the radiator cement. When water leak is excessive, replace the radiator.

Radiator water leakage test pressure	Factory specification	No leak at specified pressure
--------------------------------------	-----------------------	-------------------------------

(1) Radiator Tester (2) Adaptor

9Y1210318ENS0020US0

(4) Fuel System

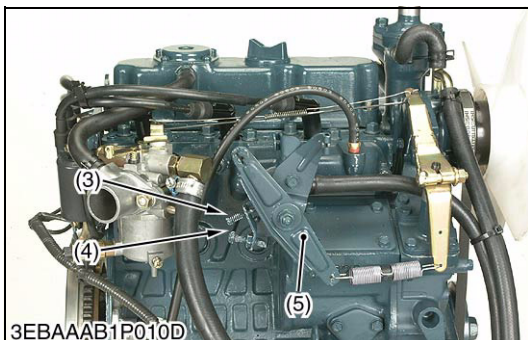
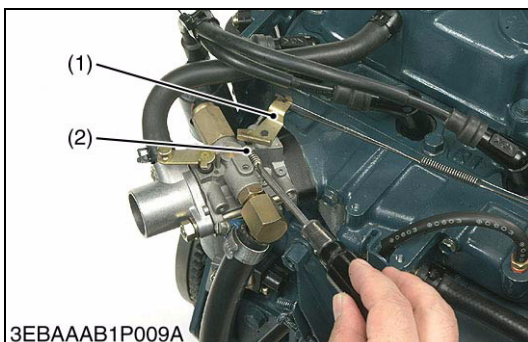
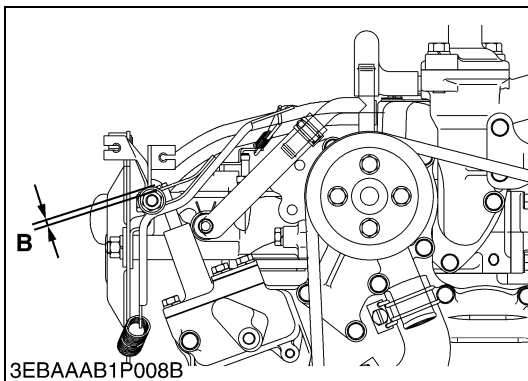
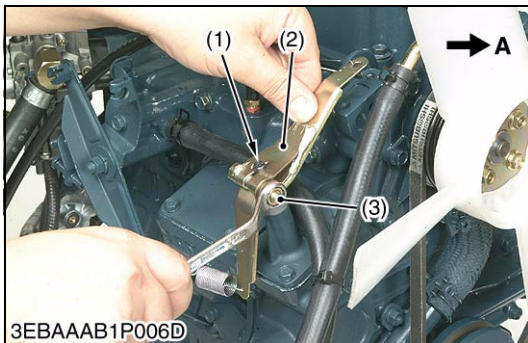

Adjusting Governor

1. Loosen the governor lever nut (3).
2. Set the throttle valve to the fully "OPEN" position with the governor lever (2), turn the groove on the governor lever shaft (1) fully clockwise with a screwdriver (to open the governor completely), and then tighten the nut (3) in this position.

Tightening torque	Governor lever nut	9.81 to 11.2 N·m 1.00 to 1.15 kgf·m 7.24 to 8.31 lbf·ft
-------------------	--------------------	---

NOTE

- Insert the governor lever to the position 2 mm (0.08 in.) (B) away from the fork lever shaft end.

- | | |
|--------------------------|----------------------------|
| (1) Governor Lever Shaft | A : Open Direction |
| (2) Governor Lever | B : 2 mm (0.08 in.) |
| (3) Governor Lever Nut | |

9Y1210318ENS0021US0

Adjusting Engine Speed

1. Warm up the engine at a medium speed for 10 to 15 minutes.
2. Engine speed is adjusted to approx. 1500 min⁻¹ (rpm) by the speed control lever (5).
3. Throttle valve (1) is closed by hand and engine speed is adjusted with the throttle adjust screw (2) to 1200 min⁻¹ (rpm) (1100 to 1300 min⁻¹ (rpm)).
4. Adjust the low-idling speed adjust screw (3) until the engine speed reaches 1500 min⁻¹ (rpm) (1400 to 1600 min⁻¹ (rpm)) with the speed control lever (5) in the minimum speed position.
5. Adjust the high-idling speed adjust screw (4) until the engine speed reaches 3850 min⁻¹ (rpm) (3850 to 3950 min⁻¹ (rpm)) with the speed control lever (5) in the maximum speed position.

Lo-idling speed	Factory specification	1500 min ⁻¹ (rpm) (1400 to 1600 min ⁻¹ (rpm))
Hi-idling speed	Factory specification	3850 min ⁻¹ (rpm) (3850 to 3950 min ⁻¹ (rpm))

- | | |
|-----------------------------|------------------------------|
| (1) Throttle Valve | (4) High-idling Adjust Screw |
| (2) Throttle Adjust Screw | (5) Speed Control Lever |
| (3) Low-idling Adjust Screw | |

9Y1210318ENS0022US0

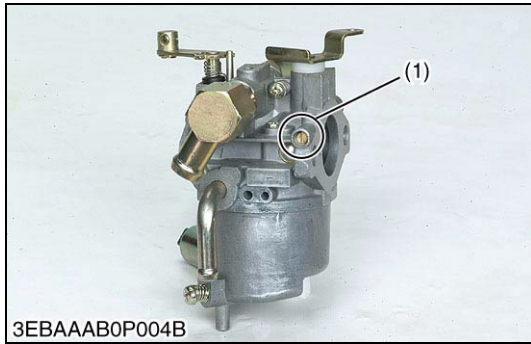

Carburetor and Dual Fuel Carburetor

The carburetor is tamper resistant; the idle mixture screw has been covered by tamper plug after adjustment at the factory.

- (1) Tamper Resistance

9Y1210571ENS0014US0

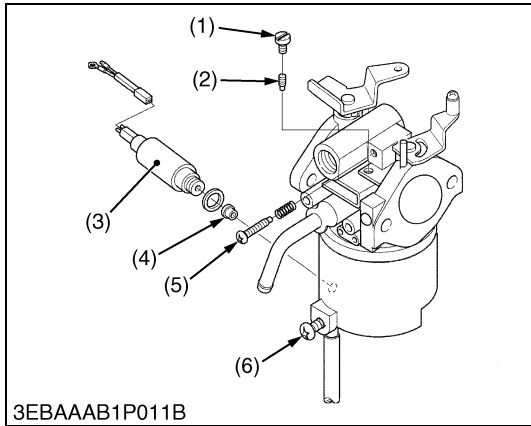

Replacement of Altitude Compensation Kit (Main Jet and Pilot Jet)

1. Remove the carburetor.
2. Loosen the drain screw (6) to let fuel out.
3. Remove the gasoline cut off solenoid (3).
4. Remove the main jet (4).
5. Install the high-altitude kit's main jet onto the carburetor.
6. Tighten the throttle adjust screw (5) and remove the pilot screw (1).
7. Replace the existing pilot jet (2) with the high-altitude kit's pilot jet.
8. Install the gasoline cut off solenoid (3).
9. Install the carburetor in place.
10. Readjust the governor.
11. Adjust the engine speed.

NOTE

- After install the carburetor, the adjustment of governor and engine speed are executed.
- Prepare a screwdriver that fits the main jet / pilot jet screws in order not to damage the main jet and pilot jet.
- Replace the air cleaner packing and the carburetor packing with new ones.
- Make sure there is no leak at the air cleaner packing and the carburetor packing.

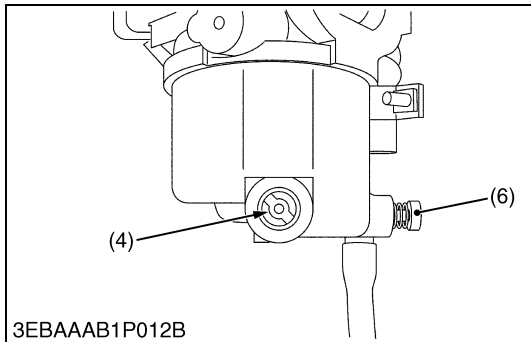

IMPORTANT

- Keep the carburetor inner parts which is removed from standard carburetor.

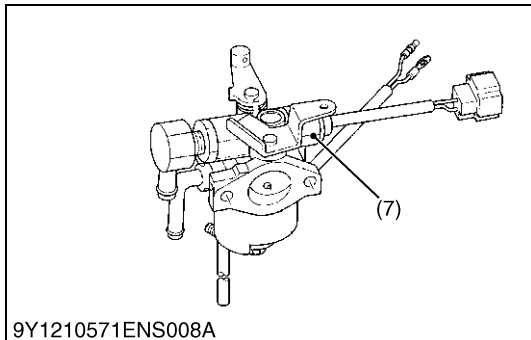

Tightening torque	Carburetor mounting nut	24 to 27 N·m 2.4 to 2.8 kgf·m 18 to 20 lbf·ft
	Gasoline cut off solenoid	7.9 to 11 N·m 0.80 to 1.2 kgf·m 5.8 to 8.6 lbf·ft
	LPG cut off solenoid	11.8 to 26.4 N·m 1.20 to 2.70 kgf·m 8.68 to 19.5 lbf·ft
	Main jet	0.98 to 2.8 N·m 0.10 to 0.29 kgf·m 0.73 to 2.0 lbf·ft
	Pilot jet	0.98 to 3.9 N·m 0.10 to 0.40 kgf·m 0.73 to 2.8 lbf·ft

- (1) Pilot Screw
- (2) Pilot Jet
- (3) Gasoline Cut Off Solenoid
- (4) Main Jet
- (5) Throttle Adjust Screw
- (6) Drain Screw
- (7) LPG Cut Off Solenoid

9Y1210571ENS0058US0

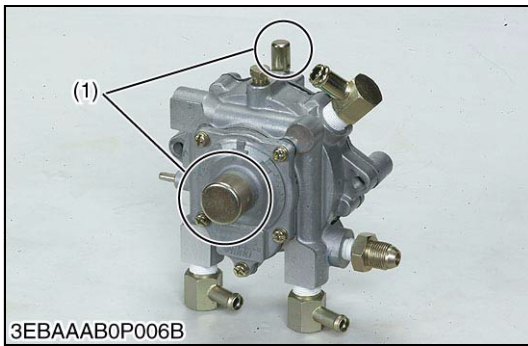

LPG Vaporizer Regulator (WG752-GL-E3, WG972-GL-E3)

LPG vaporizer regulator is tamper resistant; the main and idle pressure adjustment screws have been covered by tamper caps after adjustment at the factory.

- (1) Tamper Resistance

9Y1210571ENS0016US0

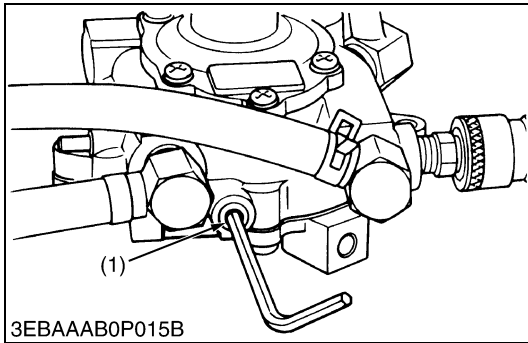

Vaporizer Joints (WG752-GL-E3, WG972-GL-E3)

1. The direction of the joint for vapor hose is decided upon and a mark (2) is made.
2. The direction of the joint for coolant hose is decided upon and a mark is made.

■ **NOTE**

- Vaporizer must be installed in an upright position (coolant hoses at bottom).
- The joints (fitting) can be adjusted to any position. The joint must be tight in that position.
- Apply an approved for GAS or LPG use liquid gasket (Three Bond 1104 or its equivalent) to thread (see figure) and tighten it.
- Drain plug (1) must not be obstructed ; so that it can be removed during maintenance.
- Apply liquid gasket to the thread of each joint and tighten them.
- After selecting the joint (fitting) positions, insure that there are no leaks.

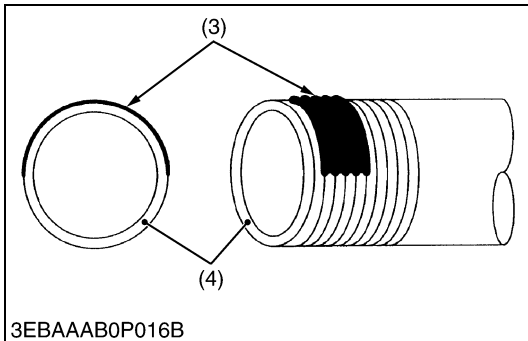
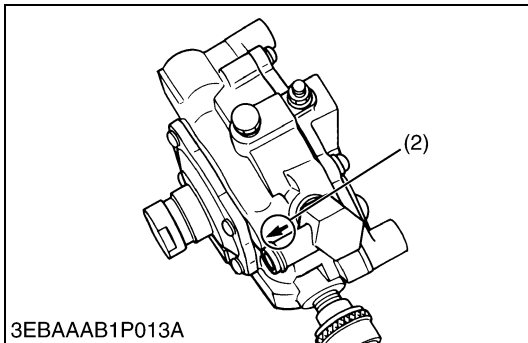

Tightening torque	Joint for LPG hose of vaporizer (local arrangement)	20 to 39 N·m 2.0 to 4.0 kgf·m 15 to 28 lbf·ft
	Joint for vapor hose of vaporizer	30 to 58 N·m 3.0 to 6.0 kgf·m 22 to 43 lbf·ft
	Joint for coolant hose of vaporizer	30 to 58 N·m 3.0 to 6.0 kgf·m 22 to 43 lbf·ft

- (1) Drain Plug
- (2) Mark

- (3) Liquid Gasket
- (4) Thread of Joint

9Y1210571ENS0017US0

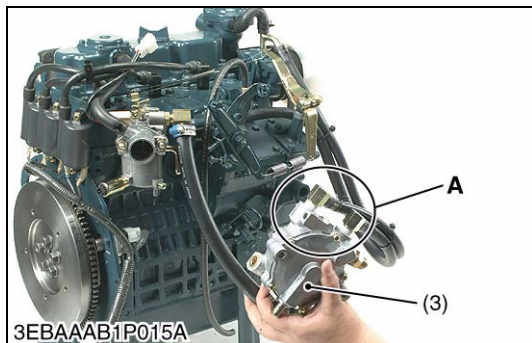

Vaporizer Piping (WG752-GL-E3, WG972-GL-E3)

1. Connect the coolant hose (1) and (2) through the vaporizer.
2. The joint part of vaporizer is adjusted to the upper side "A" and coolant is replenished through radiator, to bleed air in the vaporizer.
3. Vaporizer (3) is returned to former position.
4. Connect the vapor hose.
5. Connect the vacuum lock hose (4).
6. Tighten the vaporizer (3).
7. Connect the LPG hose.
 - O.D. of joint for vapor hose: 12.7 mm (0.500 in.)
 - O.D. of joint for coolant hose: 9.0 mm (0.35 in.)

⚠ CAUTION

- All fuel connections added to this engine must be installed by qualified personnel and utilizing recognized procedures and standards.
- These non-KUBOTA installed parts, such as hoses, fittings, piping, should be approved for LPG use and conform to UL, CSA, NFPA, and all other recognized standards.
- An approved, listed fuel filter and electromechanical positive shutoff must be installed between the LPG tank and KUBOTA vaporizer.

■ NOTE

- The LPG liquid in joint (fitting) to the vaporizer / regulator is not provided in the KIT by KUBOTA, due to the many different connection requirements by the OEM. The female thread into the vaporizer / regulator is a PT 1/4 METRIC thread. To insure good sealing the correct fitting must be used.
- Vapor hose between the vaporizer and mixer must be of 280 to 320 mm (11.1 to 12.5 in.) in length, to assure correct emissions and proper operation.
- Perform air bleeding of the vaporizer (water passage).
- Each hose must be tightened with a hose clamp.

- (1) Coolant Hose
 (2) Coolant Hose
 (3) Vaporizer
 (4) Vacuum Lock Hose

A : Joint

9Y1210571ENS0018US0

(5) Ignition System

Timing Light Test

1. Set the timing light to High-tension cord.
2. Close the fuel cocks.
3. Start the engine.
4. If the timing light blinks, the spark plug and ignition coil are normal.
5. If the timing light does not blink, check the spark plug / ignition coil.

9Y1210318ENS0029US0

Ignition Timing (WG752-G/GL-E3)

1. Using a timing light, check that the ignition timing (stamps on the flywheel) (4) is aligned with the mark (3) on the rear end plate (2).
2. If the timing is wrong, loosen the distributor mounting screw (5) and turn the distributor (6) so that the ignition timing (stamps on the flywheel) is aligned with the mark on the rear end plate.

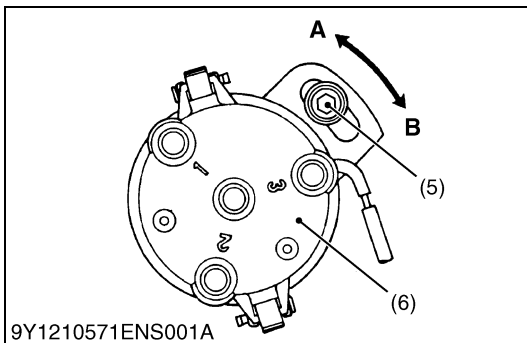
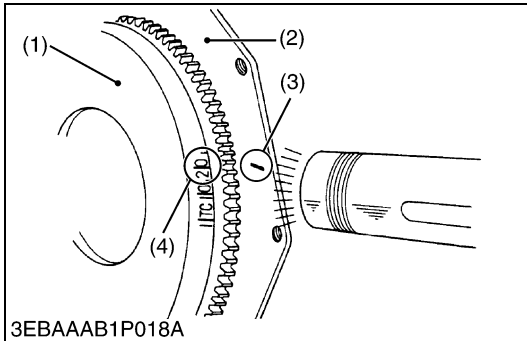

Ignition timing	Factory specification	0.31 rad (18 °) before T.D.C
-----------------	-----------------------	------------------------------

- | | |
|---------------------|--------------------------------|
| (1) Flywheel | (5) Distributor Mounting Screw |
| (2) Rear End Plate | (6) Distributor |
| (3) Mark | (A) To retard |
| (4) Ignition Timing | (B) To advance |

9Y1210571ENS0020US0

Ignition Timing (WG972-G/GL-E3)

1. Using a timing light, check that the ignition timing (stamps on the flywheel) (4) is aligned with the mark (3) on the rear end plate (2).
2. The pick-up sensor is tamper resistant (5); the ignition timing adjustment screw has been covered after adjustment at the factory.

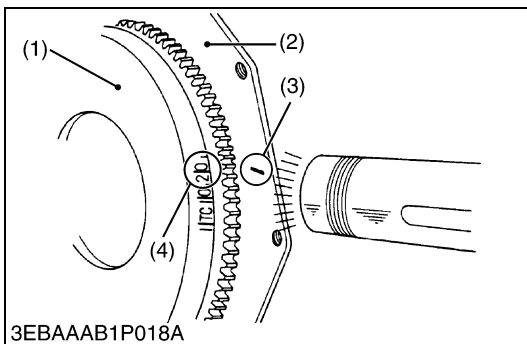

Ignition timing	Factory specification	0.34 to 0.40 rad (19 to 23 °) before T.D.C at 3600 min ⁻¹ (rpm)
-----------------	-----------------------	--

- | | |
|--------------------|-----------------------|
| (1) Flywheel | (4) Ignition Timing |
| (2) Rear End Plate | (5) Tamper Resistance |
| (3) Mark | |

9Y1210571ENS0019US0



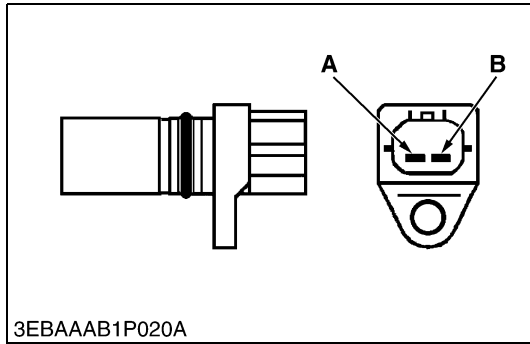

Resistance of Pick-Up Sensor (WG972-G/GL-E3)

1. Disconnect the connector.
2. Measure the resistance with an ohmmeter.
3. If the resistance is not within the factory specifications, replace it.

Resistance	Factory specification	A - B	1.85 to 2.45 kΩ at 20 °C (68 °F)
------------	-----------------------	-------	----------------------------------

■ NOTE

- This table shows the results of the test conducted by using the "Sanwa-made testers SP-10 / SP-150" (analog meter).
- Use of other testers than those above may show different measured results.

(When reassembling)

- Make sure to be connected firmly.

9Y1210571ENS0021US0

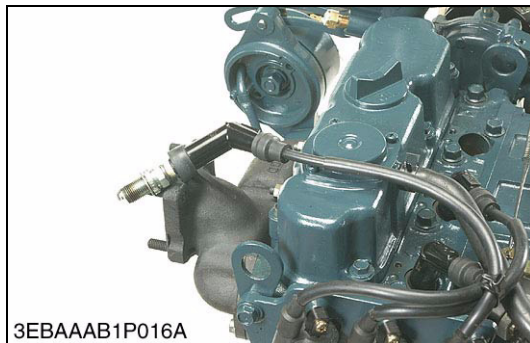

Spark Test

1. Remove the spark plug, put it inside the high voltage cord cap firmly, and then ground the threaded section to the engine body (not to painted or resin parts).
2. Rotate the starter with the key switch and check that the plug sparks.
3. If test is OK, tighten the spark plug with a plug wrench.

■ IMPORTANT

(When reassembling)

- Put the high tension cord cap inside the spark plug terminal firmly.
- Make sure that the cylinder number is corresponding to the high tension cord number.
- Wrong connection causes high temperature on catalytic muffler/converter.



CAUTION

- This test is hazardous of electric shocks. Never use hand or screwdriver to press the plug to ground it to the engine body.
- Keep inflammable away from the engine.

9Y1210571ENS0059US0

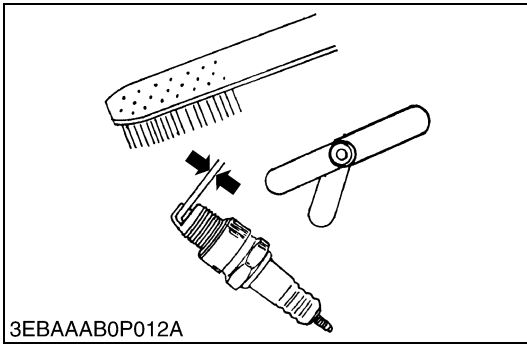

Spark Plug Gap

1. Remove the spark plug, and remove carbon from the electrode with a wire brush or other tools.
2. Measure the spark plug gap with a feeler gauge, and repair or replace the plug if the measured gap differs from the factory specification.
3. Replace the plug if the electrode or the insulator is deformed or cracked.
4. Tighten the plug with a plug wrench.

■ IMPORTANT

(When reassembling)

- Put the high tension cord cap inside the spark plug terminal firmly.
- Make sure that the cylinder number is corresponding to the high tension cord number.
- Wrong connection causes high temperature on catalytic muffler/converter.

Spark plug gap	Factory specification	WG752-G/GL-E3	1.0 to 1.1 mm 0.040 to 0.043 in.
		WG972-G/GL-E3	0.60 to 0.70 mm 0.024 to 0.027 in.
Spark plug	WG752-G/GL-E3	NGK BKR4E-11	
	WG972-G/GL-E3	NGK BKR4E	
Tightening torque	Spark plug	20 to 24 N·m 2.0 to 2.5 kgf·m 15 to 18 lbf·ft	

9Y1210571ENS0063US0

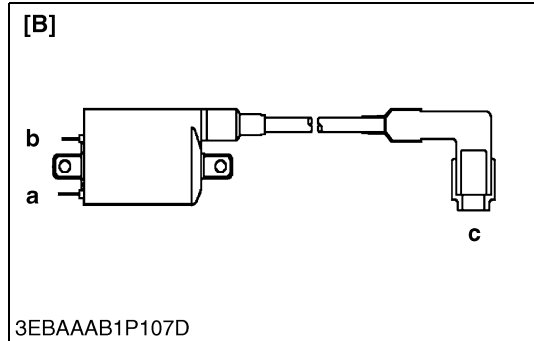
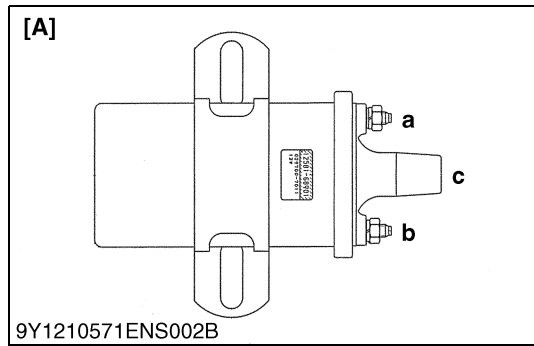

Resistance of Ignition Coil

1. Disconnect the connector.
2. Measure the resistance with an ohmmeter.
3. If the resistance is not within the factory specifications, replace it.

[WG752-G/GL-E3]

Resistance	Factory specification	a - b	1.33 to 1.63 Ω at 20 °C (68 °F)
		a - c	10.7 to 14.5 kΩ at 20 °C (68 °F)

[WG972-G/GL-E3]

Resistance	Factory specification	a - b	1.87 to 2.53 Ω at 20 °C (68 °F)
		a - c	10.4 to 15.6 kΩ at 20 °C (68 °F)

NOTE

- This table shows the results of the test conducted by using the "FLUKE MULTMETER 110 SERIES" (digital meter).
- Use of other testers than those above may show different measured results.

IMPORTANT

(When reassembling)

- Put the high tension cord cap inside the spark plug terminal firmly.
- Make sure that the cylinder number is corresponding to the high tension cord number.
- Wrong connection causes high temperature on catalytic muffler/converter.
- Connect the plus power connector at the terminal (+) of ignition coil firmly.
- Connect the signal connector at the terminal (-) of ignition coil firmly.

- a : Terminal (+) [A] WG752-G/GL-E3
- b : Terminal (-) [B] WG972-G/GL-E3
- c : To Distributor (WG752-G/GL-E3)
To Spark Plug (WG972-G/GL-E3)

9Y1210571ENS0025US0

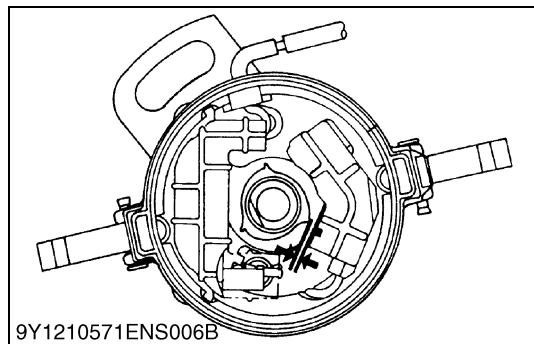

Distributor Checking (WG752-G/GL-E3)

1. Using a feeler gauge, measure the gap between the signal rotor and the pickup coil projection.

Air gap	Factory specification	0.2 to 0.4 mm 0.008 to 0.01 in.
---------	-----------------------	------------------------------------

CAUTION

- Since the ignition part of the distributor has been completely mold-shielded, it is rather difficult to check even if the following instructions are followed. Replacement of the entire assembly is best if a malfunction is suspected.

9Y1210571ENS0067US0

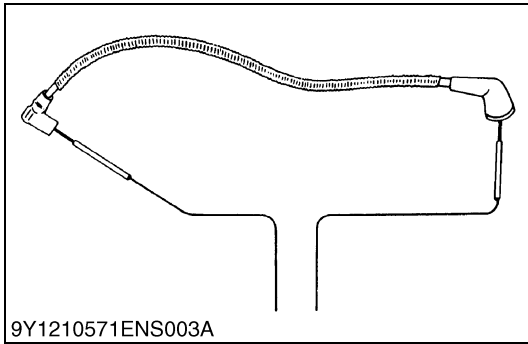

High Tension Cord (WG752-G/GL-E3)

1. Using an ohmmeter, check that the resistance does not exceed the maximum.
2. If more than maximum, check the terminals, and replace the high-tension cord and / or distributor cap as required.

Resistance	High tension cord #1	2.8 to 4.8 kΩ
	High tension cord #2	3.4 to 5.8 kΩ
	High tension cord #3	3.6 to 6.1 kΩ
	Center cord	3.1 to 5.2 kΩ

IMPORTANT

(When reassembling)

- Put the high tension cord cap inside the spark plug terminal firmly.
- Make sure that the cylinder number is corresponding to the high tension cord number.
- Wrong connection causes high temperature on catalytic muffler/converter.

9Y1210571ENS0068US0

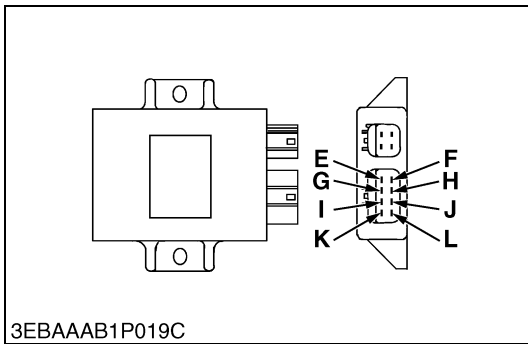

Resistance of Ignitor (WG972-G/GL-E3)

1. Disconnect the connector.
2. Measure the resistance with an ohmmeter.
3. If the resistance is not with in the factory specifications, replace it.

NOTE

(When reassembling)

- Make sure to be connected firmly.

9Y1210571ENS0024US0

Ignitor Check Chart

Positive	Negative							
	E	F	G	H	I	J	K	L
E	–	10 to 40 kΩ	10 to 40 kΩ	11 to 47 kΩ	Infinity	Infinity	Infinity	Infinity
F	10 to 40 kΩ	–	0.33 to 1.3 kΩ	1.8 to 7.3 kΩ	Infinity	Infinity	Infinity	Infinity
G	10 to 40 kΩ	0.33 to 1.3 kΩ	–	1.5 to 6.0 kΩ	Infinity	Infinity	Infinity	Infinity
H	11 to 47 kΩ	1.8 to 7.3 kΩ	1.5 to 6.0 kΩ	–	Infinity	Infinity	Infinity	Infinity
I	Infinity	Infinity	Infinity	Infinity	–	Infinity	Infinity	Infinity
J	2 MΩ (minimum)	2 MΩ (minimum)	2 MΩ (minimum)	2 MΩ (minimum)	Infinity	–	Infinity	Infinity
K	2 MΩ (minimum)	2 MΩ (minimum)	2 MΩ (minimum)	2 MΩ (minimum)	Infinity	Infinity	–	Infinity
L	2 MΩ (minimum)	2 MΩ (minimum)	2 MΩ (minimum)	2 MΩ (minimum)	Infinity	Infinity	Infinity	–

NOTE

- This table shows the results of the test conducted by using the "FLUKE MULTMETER 110 SERIES" (digital meter).
- Use of other testers than those above may show different measured results.

(When reassembling)

- Make sure to be connected firmly.

9Y1210571ENS0073US0

(6) Electrical System

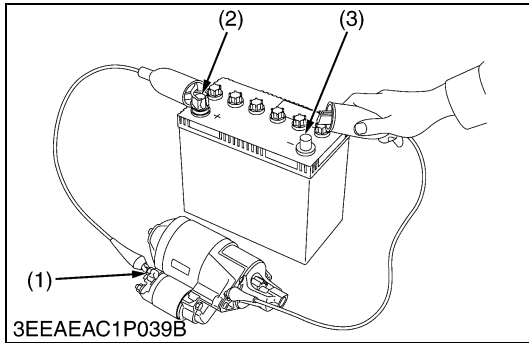

Motor Test



CAUTION

- **Secure the starter to prevent it from jumping up and down while testing the motor.**
1. Disconnect the battery negative cable from the battery.
 2. Disconnect the battery positive cable from the battery.
 3. Disconnect the leads from the starter **B** terminal.
 4. Remove the starter from the engine.
 5. Connect a jumper lead from the starter **C** terminal (1) to the battery positive terminal (2).
 6. Connect a jumper lead momentarily between the starter's body and the battery negative terminal (3).
 7. If the motor does not run, starter is failure. Repair or replace the starter.

NOTE

- **B terminal : It is the terminal which connects the cable from the battery to the starter.**
- **C terminal : It is the terminal which connects the cable from the motor to the magnet switch.**

(1) C Terminal

(3) Negative Terminal

(2) Positive Terminal

9Y1210318ENS0038US0

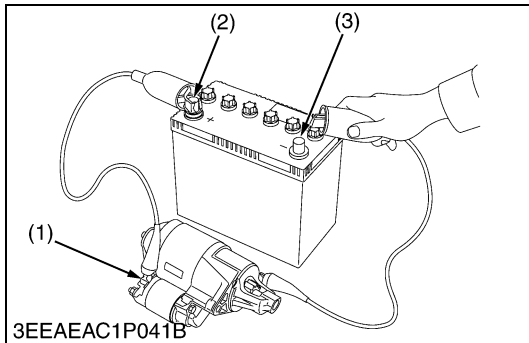

Magnetic Switch Test

1. Disconnect the battery negative cable from the battery.
2. Disconnect the battery positive cable from the battery.
3. Disconnect the leads from the starter **B** terminal.
4. Remove the starter from the engine.
5. Connect a jumper lead from the starter **S** terminal (1) to the battery positive terminal (2).
6. Connect a jumper lead momentarily between the starter's body and the battery negative terminal (3).
7. If the pinion gear does not pop out, the magnetic switch is failure. Repair or replace the starter.

NOTE

- **B terminal : It is the terminal which connects the cable from the battery to the starter.**
- **S terminal : It is the terminal which connects the cable from the starter switch to the magnet switch.**

(1) S Terminal

(3) Negative Terminal

(2) Positive Terminal

9Y1210318ENS0039US0

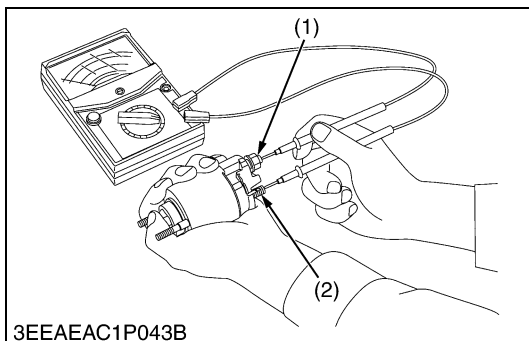

Magnet Switch Continuity Test

1. Check the continuity across the **C** terminal (1) and the **B** terminal (2) with a circuit tester, pushing in the plunger.
2. If not continuous or if a certain value is indicated, replace the magnet switch.

(1) C Terminal

(2) B Terminal

9Y1210318ENS0040US0

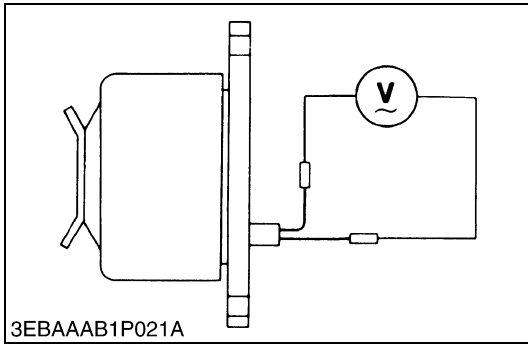

No-load Dynamo Output

1. Disconnect the lead wires from the dynamo.
2. Start the engine and operate the dynamo at the specified speed.
3. Measure the output voltage with a volt meter.
If the measurement is not within the specified values, replace the dynamo.

No-load output voltage	Factory specification	AC 20 V or more at 5200 min ⁻¹ (rpm)
------------------------	-----------------------	--

9Y1210318ENS0041US0

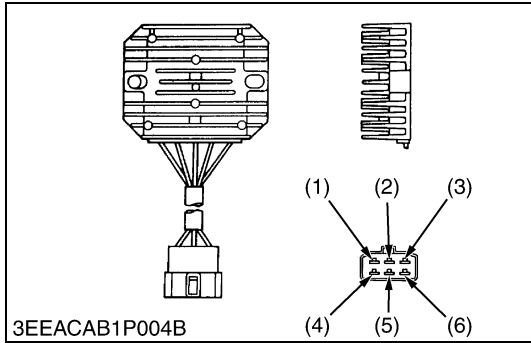

Regulator

1. The engine is started.
2. Measure the output voltage of the regulator with the voltmeter.

Output voltage	(6) - (2)	14 V to 15 V
----------------	-----------	--------------

3. When the measurement is not the above table value, measure the input voltage of the regulator with the voltmeter.

Input voltage	(1) - (3)	Dynamo output voltage
---------------	-----------	-----------------------

4. When the measurement is the above table value, the regulator is failure. Exchange it.

NOTE

- When the input voltage of the regulator is out of specification, check the generator.

- | | |
|-------------------------|-----------------------|
| (1) Terminal (Sky Blue) | (4) Terminal (Green) |
| (2) Terminal (Black) | (5) Terminal (Yellow) |
| (3) Terminal (Sky Blue) | (6) Terminal (Red) |

9Y1210571ENS0060US0

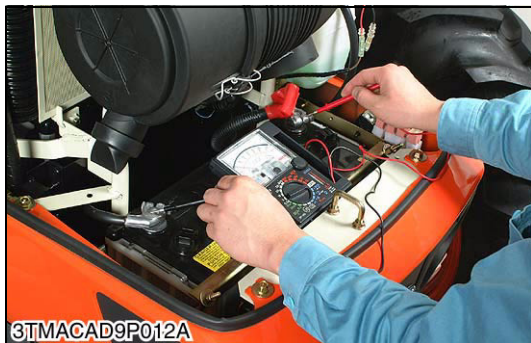

Alternator on Unit Test

(Before testing)

- Before alternator on unit test, check the battery terminal connections, circuit connection, fan belt tension, charging indicator lamp, fuses on the circuit, and abnormal noise from the alternator.
- Prepare full charged battery for the test.

NOTE

- Be careful not to touch the rotating engine parts while engine is running.

Keep safety distance from the engine rotating parts.

1. Start the engine.
2. When the engine is operating measure the voltage between two battery terminals. If the voltage is between 14.2 V and 14.8 V, the alternator is operating normally.
3. If the results of alternator on unit test are not within the specifications, disassemble the alternator and check the each component part for finding out the failure. See the "DISASSEMBLING AND ASSEMBLING" and "SERVICING" for alternator.

Regulating voltage at no load	Factory specification	14.2 to 14.8 V at 5000 min ⁻¹ (rpm), 25 °C (77 °F)
-------------------------------	-----------------------	---

9Y1210318ENS0043US0

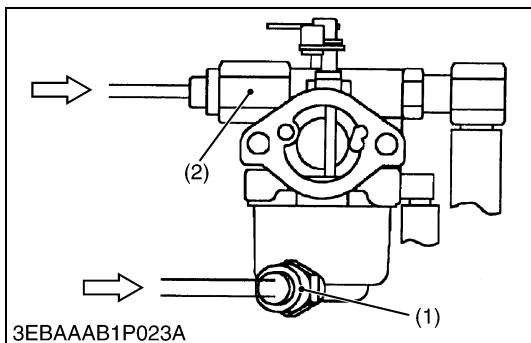

Fuel Cut Off Solenoid

1. Disconnect the connector.
2. Measure the resistance with an ohmmeter between the connector terminals.
3. If the factory specification is not indicated the solenoid is faulty.

Gasoline cut off solenoid	Factory specification	Approx. 38 Ω at 20 °C (68 °F)
LPG cut off solenoid	Factory specification	Approx. 28 Ω at 20 °C (68 °F)

- | | |
|-------------------------------|--------------------------|
| (1) Gasoline Cut Off Solenoid | (2) LPG Cut Off Solenoid |
|-------------------------------|--------------------------|

9Y1210571ENS0026US0

[2] DISASSEMBLING AND ASSEMBLING

■ IMPORTANT

- When reassembling, replace all of the O-rings and gaskets by new ones.
- When disassembling the LPG engine after completely consuming the fuel in piping.

9Y1210318ENS0047US0

(1) Draining Coolant and Engine Oil

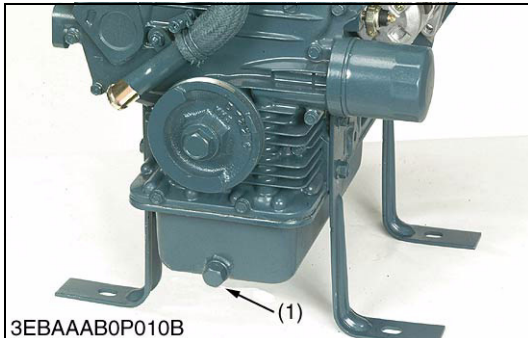

Draining Engine Oil

1. Start and warm up the engine for approx. 5 minutes.
2. Place an oil pan underneath the engine.
3. Remove the drain plug (1) to drain oil.
4. After draining, screw in the drain plug (1).

(When refilling)

- Fill the engine oil up to the upper line on the dipstick (2).

■ IMPORTANT

- When using an oil of different maker or viscosity from the previous one, remove all of the old oil.
- Never mix two different types of oil.
- Engine oil should have properties of API classification SH.
- Use the proper SAE Engine Oil according to ambient temperature.

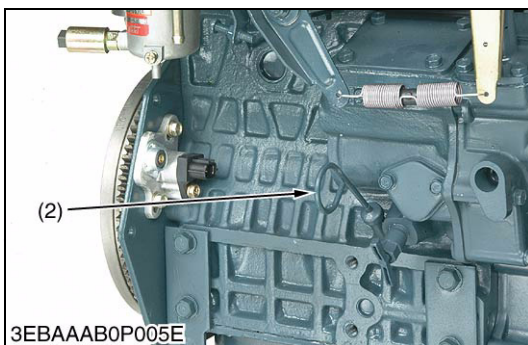

Above 25 °C (77 °F)	SAE30 or SAE10W-30
0 °C to 25 °C (32 °F to 77 °F)	SAE20 or SAE10W-30
Below 0 °C (32 °F)	SAE10W or SAE10W-30

Engine oil capacity	WG752-G/GL-E3	3.25 L 0.859 U.S.gals
	WG972-G/GL-E3	3.4 L 0.90 U.S.gals

Tightening torque	Drain plug	33 to 37 N·m 3.3 to 3.8 kgf·m 24 to 27 lbf·ft
-------------------	------------	---

(1) Drain Plug

(2) Dipstick

9Y1210571ENS0027US0

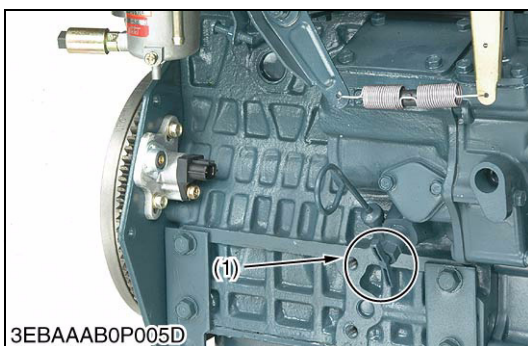

Draining Coolant

⚠ CAUTION

- Never remove radiator cap while operating or immediately after stopping. Otherwise, hot water will spout out from the radiator. Wait for more than ten minutes to cool the radiator, before opening the cap.

1. Prepare a bucket. Open the coolant drain cock.

(1) Coolant Drain Cock

9Y1210318ENS0049US0

(2) External Components



Alternator, Starter and Others

1. Remove the air cleaner, catalytic muffler/convertor and exhaust manifold.
2. Remove the cooling fan (1), fan pulley and fan belt (2).
3. Remove the alternator.
4. Remove the starter.

(When reassembling)

- Check to see that there are no cracks on the belt surface.
- Replace the exhaust manifold gasket with a new one.
- Replace the muffler/convertor gasket with a new one.

■ IMPORTANT

- After reassembling the fan belt (2), be sure to adjust the fan belt tension.
- Do not confuse the direction of the cooling fan (1).
- To trace of the catalytic muffler/convertor, put down the catalyst identification and engine identification when new service catalytic muffler/convertor is installed.

Tightening torque	Exhaust manifold mounting screw/nut	9.81 to 11.2 N·m 1.00 to 1.15 kgf·m 7.24 to 8.31 lbf·ft
	Catalytic Muffler mounting nut	23.5 to 27.5 N·m 2.40 to 2.80 kgf·m 17.4 to 20.2 lbf·ft
	Catalytic converter mounting nut	23.5 to 27.5 N·m 2.40 to 2.80 kgf·m 17.4 to 20.2 lbf·ft

(1) Cooling Fan

(2) Fan Belt

9Y1210571ENS0061US0



Fuel Line

1. Disconnect the gasoline hose from the connector (1).

(1) Gasoline Hose Connector

9Y1210318ENS0051US0

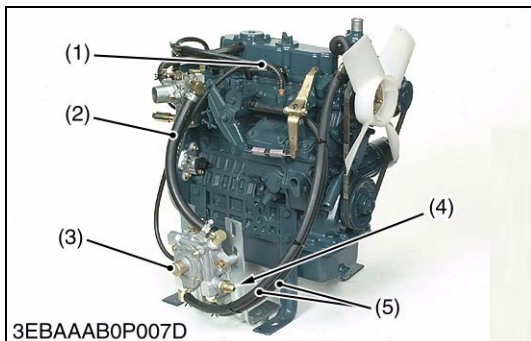

LPG Hose and Coolant Hose (WG752-GL-E3, WG972-GL-E3)

⚠ CAUTION

- Vent the air of the water passage of vaporizer (3) after detaching the coolant hose (5).

1. Disconnect the LPG hose from the connector (4).
2. Disconnect the coolant hose (5).
3. Disconnect the vapor hose (2) and vacuum lock hose (1).
4. Remove the vaporizer (3) (if necessary).

■ IMPORTANT

- When disassembling the fuel system, make sure that the fuel valve is closed.

(When reassembling)

- Bleed the vaporizer after supplying coolant.

(1) Vacuum Lock Hose

(4) LPG Hose Connector

(2) Vapor Hose

(5) Coolant Hose

(3) Vaporizer

9Y1210571ENS0028US0

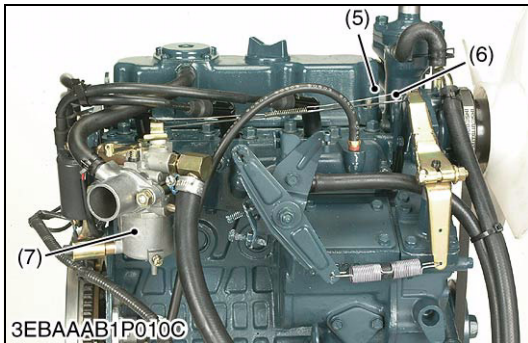

Carburetor (Mechanical Governor) (WG752-G-E3, WG972-G-E3)

1. Disconnect the connector of LPG cut off solenoid (for WG752-GL-E3 and WG972-GL-E3) (4) and the connector of gasoline cut off solenoid (3).
2. Disconnect the breather hose (1).
3. Remove the air cleaner flange (2) and air cleaner gasket.
4. Disconnect the governor rod (6) from the carburetor (7) and remove the carburetor (7).
5. Remove the carburetor flange and gasket.

■ **NOTE**

- Do not bend the governor rod (6), when disassembling and assembling the carburetor (7).
- Do not stretch the governor rod spring (5) when disassembling and assembling the carburetor (7).

Tightening torque	Carburetor mounting nut	24 to 27 N·m 2.4 to 2.8 kgf·m 18 to 20 lbf·ft
-------------------	-------------------------	---

- | | |
|--|-------------------------|
| (1) Breather Hose | (5) Governor Rod spring |
| (2) Air Cleaner Flange | (6) Governor Rod |
| (3) Connector of Gasoline Cut Off Solenoid | (7) Carburetor |
| (4) Connector of LPG Cut Off Solenoid | |

9Y1210571ENS0031US0

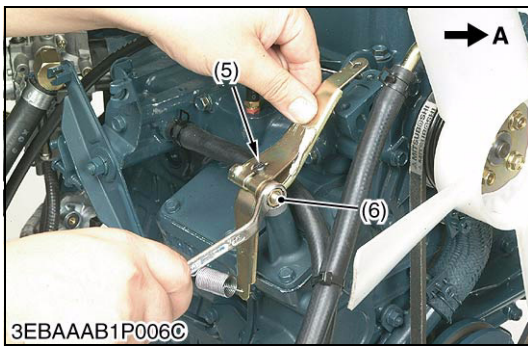
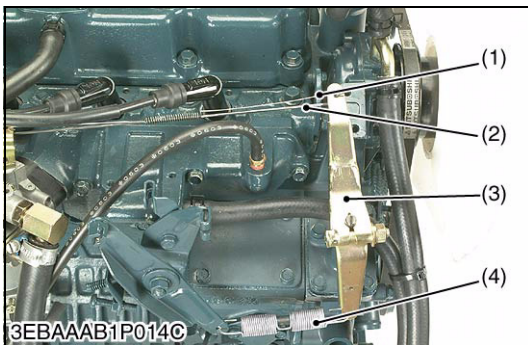

Governor Lever

1. Disconnect the governor rod (2) and rod spring (1) from governor lever (3).
2. Disconnect the governor spring (4) from governor lever.
3. Loosen the governor lever nut (6).
4. Remove the governor lever (3) from governor lever shaft (5).

(When reassembling)

- Loosen the governor lever nut (6).
- Set the throttle valve to the fully **"OPEN"** position with the governor lever (3), turn the groove on the governor lever shaft (5) fully clockwise with a screwdriver (to open the governor completely), and then tighten the nut (6) in this position.

Tightening torque	Governor lever nut	9.81 to 11.2 N·m 1.00 to 1.15 kgf·m 7.24 to 8.31 lbf·ft
-------------------	--------------------	---

■ **IMPORTANT**

- After assembly of engine is completed, the adjustment of governor is executed.
- Insert the governor lever to the position 2 mm (0.08 in.) (B) away from the governor lever shaft end.

- | | |
|--------------------------|----------------------------|
| (1) Governor Rod Spring | A : Open Direction |
| (2) Governor Rod | B : 2 mm (0.08 in.) |
| (3) Governor Lever | |
| (4) Governor Spring | |
| (5) Governor Lever Shaft | |
| (6) Governor Lever Nut | |

9Y1210318ENS0060US0

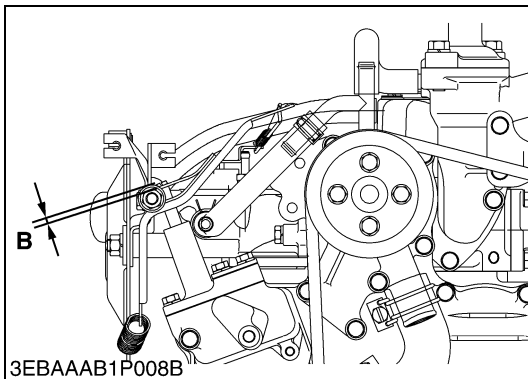

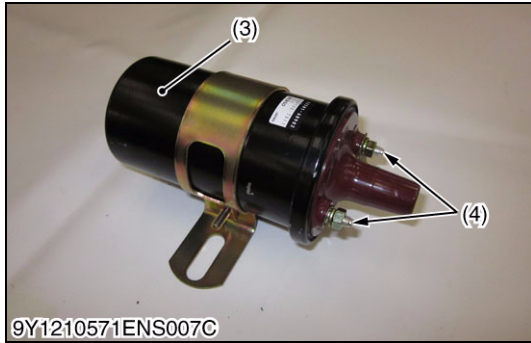
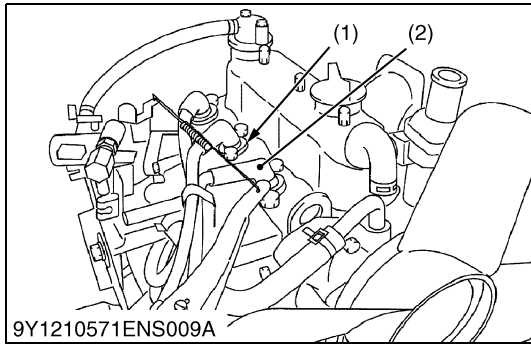

Ignition Coil and Spark Plug (WG752-G/GL-E3)

1. Disconnect the spark plug cap (2).
2. Disconnect the center cord.
3. Disconnect the wire harness from ignition coil terminal (4).
4. Remove the ignition coil (3).
5. Remove the spark plug (1).

(When reassembling)

- Tighten the spark plug (1) with a plug wrench.

■ IMPORTANT

(When reassembling)

- Put the high tension cord cap inside the spark plug terminal firmly.
- Make sure that the cylinder number is corresponding to the high tension cord number.
- Wrong connection causes high temperature on catalytic muffler / converter.

- | | |
|--------------------|----------------------------|
| (1) Spark Plug | (3) Ignition Coil |
| (2) Spark Plug Cap | (4) Ignition Coil Terminal |

9Y1210571ENS0070US0

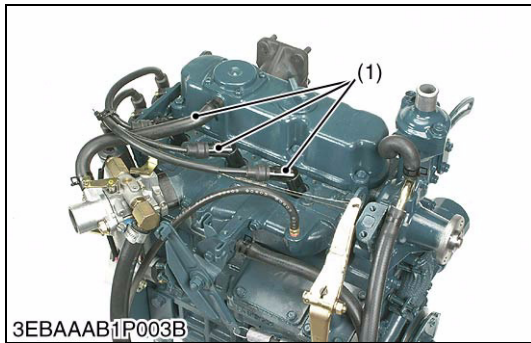

Ignition Coil and Spark Plug (WG972-G/GL-E3)

1. Disconnect the spark plug cap (1).
2. Disconnect the ignition coil connector (3).
3. Remove the ignition coil (2).

- A : for No. 1 cylinder
- B : for No. 2 cylinder
- C : for No. 3 cylinder

4. Remove the spark plug (4).

(When reassembling)

- Tighten the spark plug with a plug wrench.

■ IMPORTANT

(When reassembling)

- Put the high tension cord cap inside the spark plug terminal firmly.
- Make sure that the cylinder number is corresponding to the high tension cord number.
- Wrong connection causes high temperature on catalytic muffler/converter.

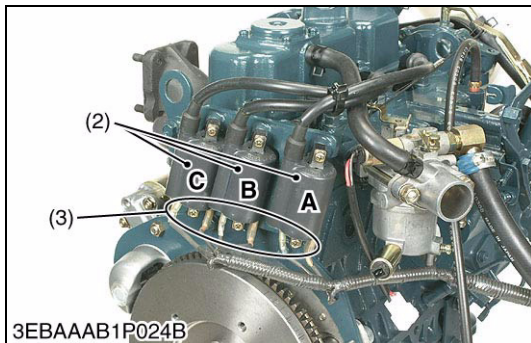

Tightening torque	Spark plug	20 to 24 N·m 2.0 to 2.5 kgf·m 15 to 18 lbf·ft
-------------------	------------	---

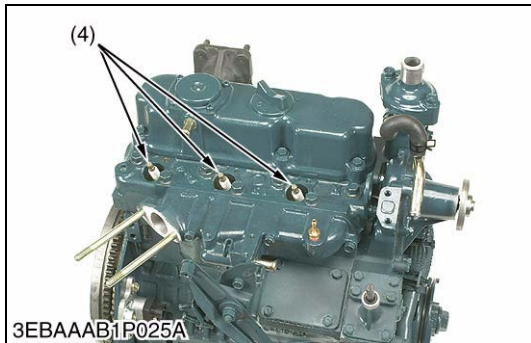

- | | |
|--------------------|-----------------------------|
| (1) Spark Plug Cap | (3) Ignition Coil Connector |
| (2) Ignition Coil | (4) Spark Plug |

9Y1210571ENS0030US0

(3) Cylinder Head, Valves and Oil Pan

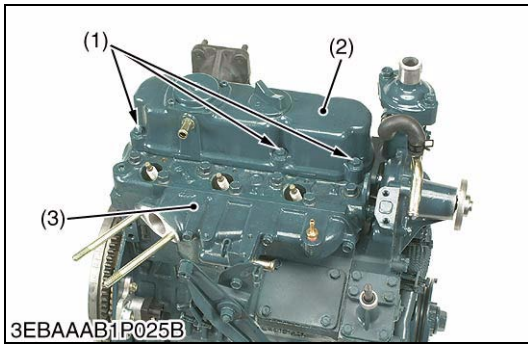

Cylinder Head Cover

1. Remove the head cover screws/nuts (1).
2. Remove the cylinder head cover (2).
3. Remove the intake manifold (3).

(When reassembling)

- Check to see if the cylinder head cover gasket is not defective.

[WG752-G/GL-E3]

Tightening torque	Cylinder head cover cap nut	4.0 to 5.8 N·m 0.40 to 0.60 kgf·m 2.8 to 4.3 lbf·ft
-------------------	-----------------------------	---

[WG972-G/GL-E3]

Tightening torque	Cylinder head cover screw	9.81 to 11.2 N·m 1.00 to 1.15 kgf·m 7.24 to 8.31 lbf·ft
-------------------	---------------------------	---

- (1) Head Cover Screws/Nuts (3) Intake Manifold
(2) Cylinder Head Cover

9Y1210571ENS0064US0

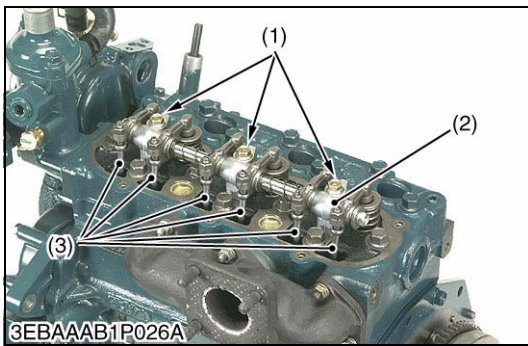

Rocker Arm and Push Rod

1. Remove the rocker arm bracket screws/nuts(1).
2. Remove the rocker arm assembly (2).
3. Remove the push rods (3).

(When reassembling)

- When putting the push rods (3) onto the tappets (4), check to see if their ends are properly engaged with the dimples.

■ **IMPORTANT**

- **After installing the rocker arm, be sure to adjust the valve clearance.**

[WG752-G/GL-E3]

Tightening torque	Rocket arm bracket nut	9.81 to 11.2 N·m 1.00 to 1.15 kgf·m 7.24 to 8.31 lbf·ft
-------------------	------------------------	---

[WG972-G/GL-E3]

Tightening torque	Rocker arm bracket screw	12 to 14 N·m 1.2 to 1.5 kgf·m 8.7 to 10 lbf·ft
-------------------	--------------------------	--

- (1) Rocker Arm Bracket Screws/Nuts (3) Push Rod
(2) Rocker Arm Assembly (4) Tappet

9Y1210571ENS0065US0

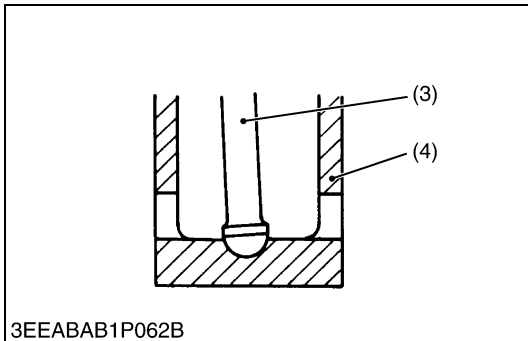

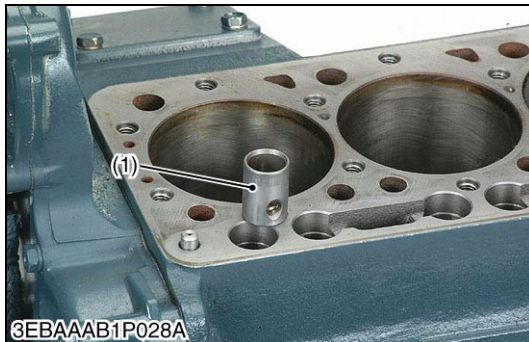
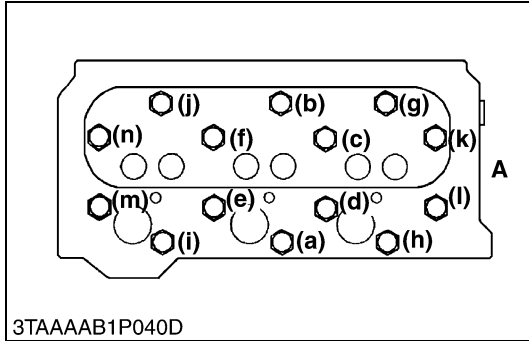
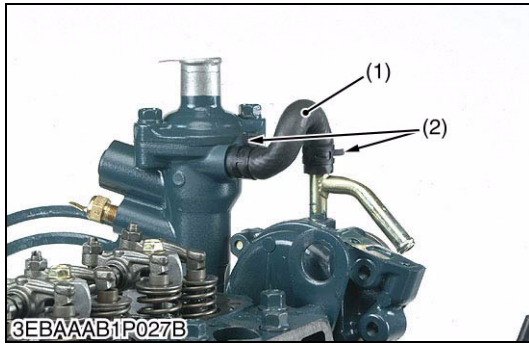

Cylinder Head

1. Loosen the pipe clamps (2), and remove the water return hose (1).
2. Remove the cylinder head screw in the order of (n) to (a).
3. Lift up the cylinder head to detach.
4. Remove the cylinder head gasket.

(When reassembling)

- Replace the cylinder head gasket with a new one.
- Tighten the cylinder head screws after applying sufficient oil.
- Tighten the cylinder head screws in order of (a) to (n).
- Tighten them uniformly, or the head may deform in the long run.

[WG752-G/GL-E3]

Tightening torque	Cylinder head screw	38 to 42 N·m 3.8 to 4.3 kgf·m 28 to 31 lbf·ft
-------------------	---------------------	---

[WG972-G/GL-E3]

Tightening torque	Cylinder head screw	40 to 44 N·m 4.0 to 4.5 kgf·m 29 to 32 lbf·ft
-------------------	---------------------	---

- (1) Water Return Hose
- (2) Hose Clamp

A : Gear Case Side
(n) to (a) : To Loosen
(a) to (n) : To Tighten

9Y1210571ENS0066US0

Tappets

1. Remove the tappets (1) from the crankcase.

(When reassembling)

- Visually check the contact between tappets and cams for proper rotation. If defect is found, replace tappets.
- Before installing the tappets, apply engine oil thinly around them.

■ IMPORTANT

- **Do not change the combination of tappet and tappet guide.**

- (1) Tappet

9Y1210318ENS0065US0

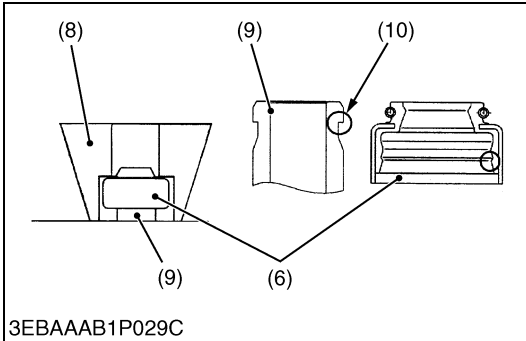
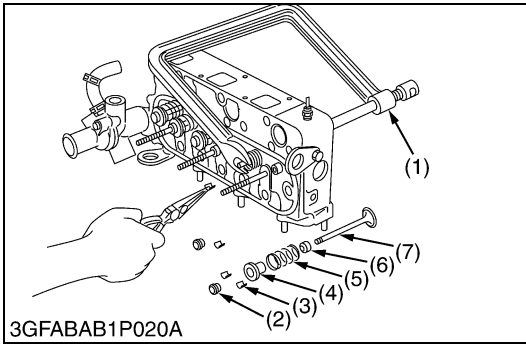

Valves

1. Remove the valve caps (2).
2. Remove the valve spring collet (3), pushing the valve spring retainer (4) with valve spring replacer (1).
3. Remove the valve spring retainer (4), valve spring (5) and valve stem seal (6).
4. Remove the valve (7).

(When reassembling)

- Wash the valve stem and valve guide hole, and apply engine oil sufficiently.
- After installing the valve spring collets, lightly tap the stem to assure proper fit with a plastic hammer.
- Install a new stem seal on the valve guide (9) vertically with a jig (8) when insert the stem seal (6). (See page G-30: "Valve Stem Seal Replacing Tool".)

■ IMPORTANT

- **Be sure stem seal (6) seats firmly against groove of valve guide (10).**
- **Use care to prevent damage to lip of stem seal and valve stem when detach the valve spring collet by compressing the valve spring.**
- **Do not change the combination of valve and valve guide.**

- | | |
|---------------------------|----------------------------|
| (1) Valve Spring Replacer | (6) Valve Stem Seal |
| (2) Valve Cap | (7) Valve |
| (3) Valve Spring Collet | (8) Jig |
| (4) Valve Spring Retainer | (9) Valve Guide |
| (5) Valve Spring | (10) Groove of Valve Guide |

9Y1210318ENS0066US0

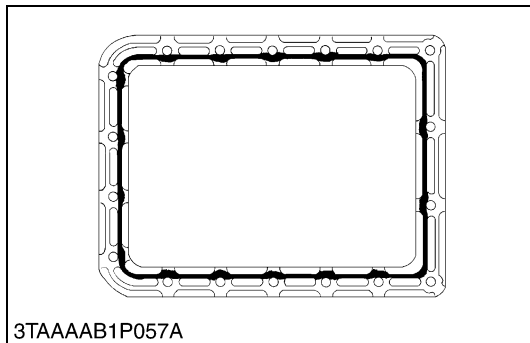
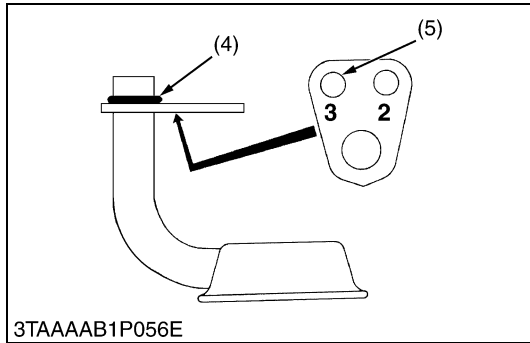
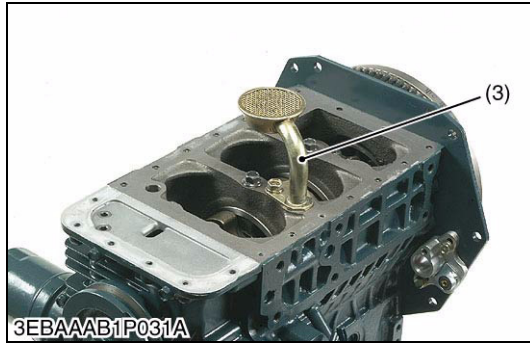
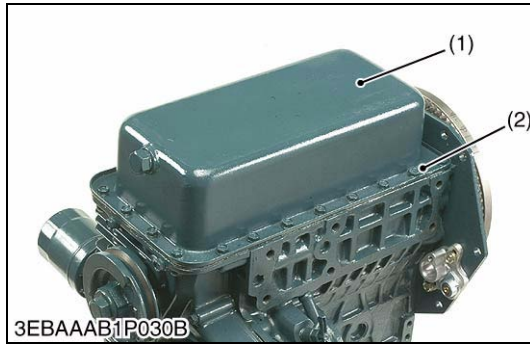

Oil Pan and Oil Strainer

1. Remove the oil pan mounting screws (2).
2. Remove the oil pan (1) by lightly tapping the rim of the pan with a wooden hammer.
3. Remove the oil strainer (3).

(When reassembling)

- After cleaning the oil strainer, check to see that the filter mesh is clean, and install it.
- Visually check the O-ring (4), apply engine oil, and install it.
- Securely fit the O-ring to the oil strainer.
- To avoid uneven tightening, tighten oil pan mounting screws in diagonal order from the center.
- Using the hole numbered "3" (5), install the oil strainer by mounting screw.

■ IMPORTANT

- **Scrape off the old adhesive completely. Wipe the sealing surface clean. Now apply new adhesive 3.0 to 5.0 mm (0.12 to 0.19 in.) thick all over the contact surface. Apply the adhesive also on the center of the flange as well as on the inner wall of each bolt hole.**
- **Cut the nozzle of the "liquid gasket" (Three Bond 1207D or equivalent) container at its second notch. Apply "liquid gasket" about 5.0 mm (0.19 in.) thick. Within 20 minutes after the application of fluid sealant, reassemble the components. Wait then for about 30 minutes, and pour oil in the crankcase.**

- | | |
|----------------------------|-----------------------|
| (1) Oil Pan | (4) O-ring |
| (2) Oil Pan Mounting Screw | (5) Hole Numbered "3" |
| (3) Oil Strainer | |

9Y1210318ENS0067US0

(4) Thermostat

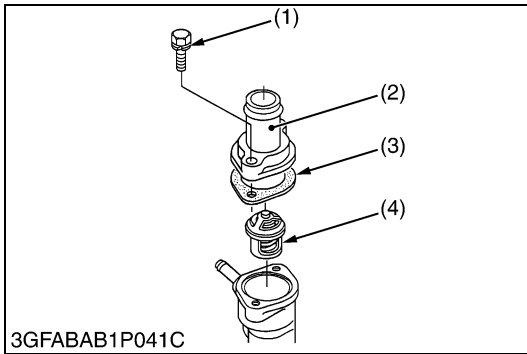

3GFABAB1P041C

Thermostat Assembly

1. Remove the thermostat cover mounting screws (1), and remove the thermostat cover (2).
2. Remove the thermostat assembly (4).

(When reassembling)

- Apply a liquid gasket (Three Bond 1215 or equivalent) only at the thermostat cover side of the gasket (3).

- (1) Thermostat Cover Mounting Screw (3) Thermostat Cover Gasket
 (2) Thermostat Cover (4) Thermostat Assembly

9Y1210318ENS0068US0

(5) Timing Gear, Camshaft and Distributor Shaft (WG752-G/GL-E3) / Gear Shaft (WG972-G/GL-E3)

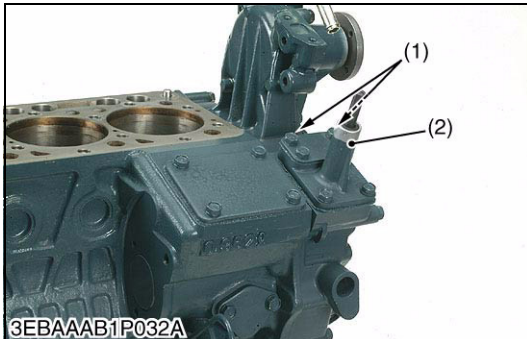

3EBAAAB1P032A

Speed Control Plate

1. Remove the screws (1) and separate the speed control plate (2).

(When reassembling)

- Remove the speed control plate (for mechanical governor only) (2) and make sure that the governor lever shaft (3) is correctly set in the governor fork (4).

■ NOTE

- **Electronic governor specification engine has modified from speed control plate to cover plate.**

- (1) Screws and Copper Washers (3) Governor Lever Shaft
 (2) Speed Control Plate (4) Governor Fork

9Y1210318ENS0069US0

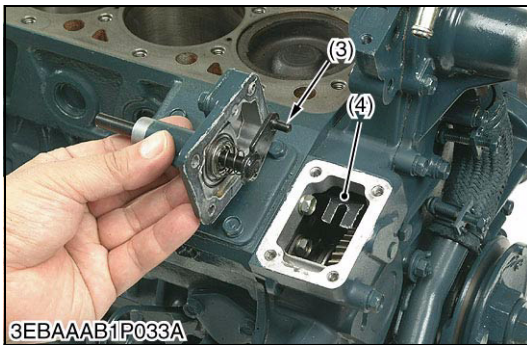

3EBAAAB1P033A

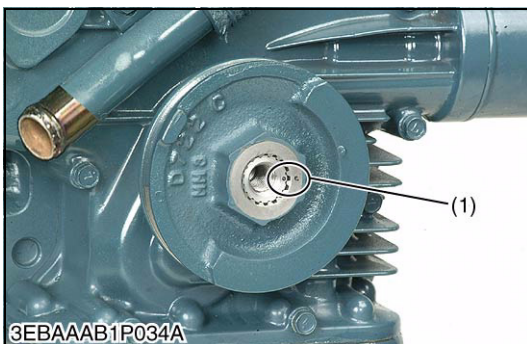

3EBAAAB1P034A

Fan Drive Pulley

1. Secure the flywheel to keep it from turning.
2. Remove the fan drive pulley screw.
3. Draw out the fan drive pulley with a puller.

(When reassembling)

- Install the pulley to the crankshaft, aligning the mark (1) on them.
- Apply engine oil to the fan drive pulley retaining screws. And tighten them.

Tightening torque	Fan drive pulley screw	118 to 127 N·m 12.0 to 13.0 kgf·m 86.8 to 94.0 lbf·ft
-------------------	------------------------	---

- (1) Alignment Mark

9Y1210318ENS0070US0

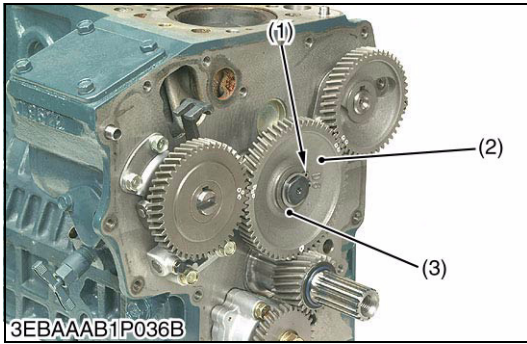

Idle Gear

1. Remove the external snap ring (1), the collar (3) and the idle gear (2).
2. Remove the idle gear shaft mounting screws (4).
3. Remove the idle gear shaft (5).

(When reassembling)

- Apply engine oil to the idle gear shaft mounting screw (4). And tighten them.
- Install the idle gear, aligning the mark (6) on the gears referring to the photo.

Tightening torque	Idle gear shaft mounting screw	9.81 to 11.2 N·m 1.00 to 1.15 kgf·m 7.24 to 8.31 lbf·ft
-------------------	--------------------------------	---

- | | |
|------------------------|------------------------------------|
| (1) External Snap Ring | (4) Idle Gear Shaft Mounting Screw |
| (2) Idle Gear | (5) Idle Gear Shaft |
| (3) Idle Gear Collar | (6) Alignment Mark |

9Y1210318ENS0073US0

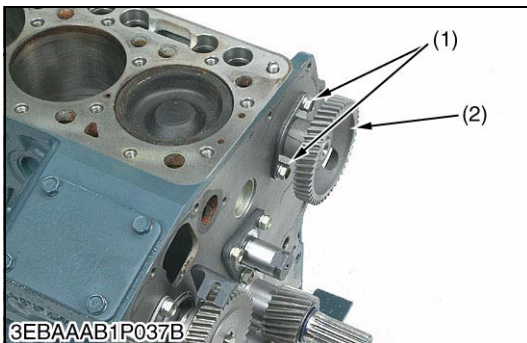
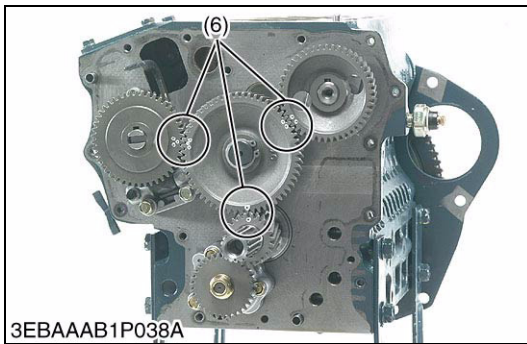
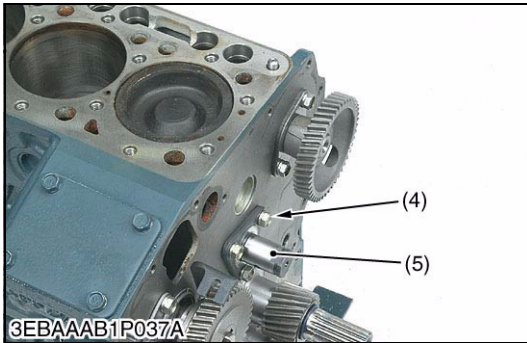

Camshaft

1. Remove the camshaft mounting screws (1) and draw out the camshaft with gear (2) on it.

(When reassembling)

- When install the camshaft, apply engine oil to the camshaft journals.
- Apply engine oil to the camshaft mounting screws. And tighten them.

- | | |
|-----------------------------|-------------------|
| (1) Camshaft Mounting Screw | (2) Camshaft Gear |
|-----------------------------|-------------------|

9Y1210318ENS0074US0

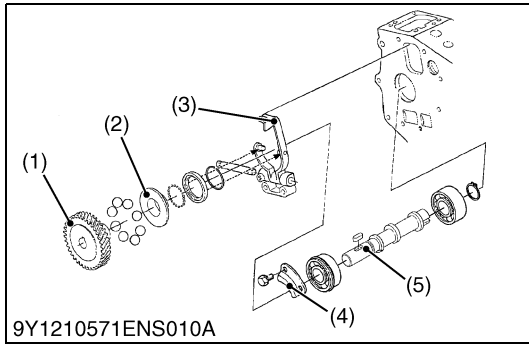

**Distributor Shaft (WG752-G/GL-E3)/
Gear Shaft (WG972-G/GL-E3)**

1. Remove the stopper (4).
2. Remove the fork lever holder (for mechanical governor only) mounting screws (6), then draw out the injection pump gear (1) and distributor shaft/gear shaft (5) with the governor fork assembly.

■ **NOTE**

- **Electronic governor specification engine does not install the fork lever (3) and governor assembly.**

- | | |
|-------------------------|--------------------------------------|
| (1) Injection Pump Gear | (4) Stopper |
| (2) Governor Sleeve | (5) Distributor Shaft/Gear Shaft |
| (3) Fork Lever | (6) Fork Lever Holder Mounting Screw |

9Y1210318ENS0075US0

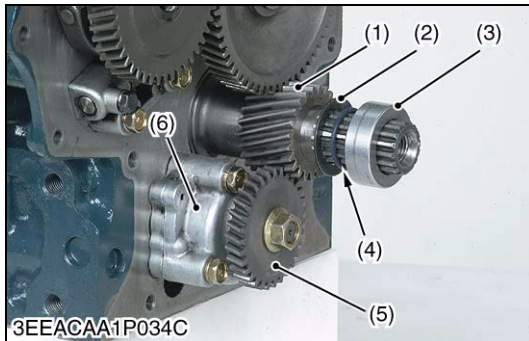
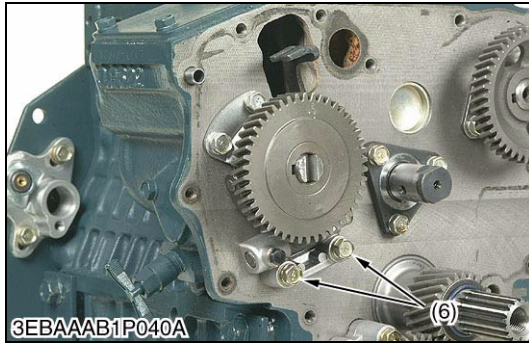

Oil Pump and Crankshaft Gear

1. Remove the oil pump gear (5).
2. Remove the oil pump (6).
3. Remove the collar (3), O-ring (4) and crankshaft oil slinger (2).

(When reassembling)

- Install the collar (3) after aligning the marks on the gear.

- | | |
|----------------------------|-------------------|
| (1) Crankshaft Gear | (4) O-ring |
| (2) Crankshaft Oil Slinger | (5) Oil Pump Gear |
| (3) Crankshaft Collar | (6) Oil Pump |

9Y1210318ENS0076US0

(6) Piston and Connecting Rod

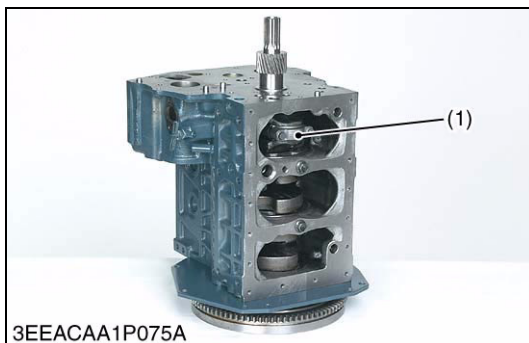

Connecting Rod Cap

1. Remove the connecting rod caps (1) using a hexagonal 8 mm socket.

(When reassembling)

- Align the marks (a) with each other. (Face the marks toward the intake manifold.)
- Apply engine oil to the connecting rod screws and lightly screw it in by hand, then tighten it to the specified torque.
If the connecting rod screw won't be screwed in smoothly, clean the threads.
If the connecting rod screw is still hard to screw in, replace it.

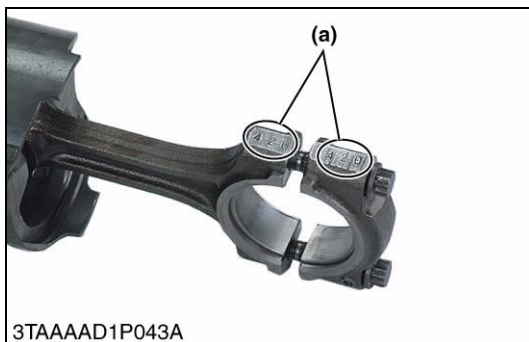

Tightening torque	Connecting rod screw	27 to 30 N·m 2.7 to 3.1 kgf·m 20 to 22 lbf·ft
-------------------	----------------------	---

- | | |
|------------------------|----------|
| (1) Connecting Rod Cap | (a) Mark |
|------------------------|----------|

9Y1210318ENS0077US0

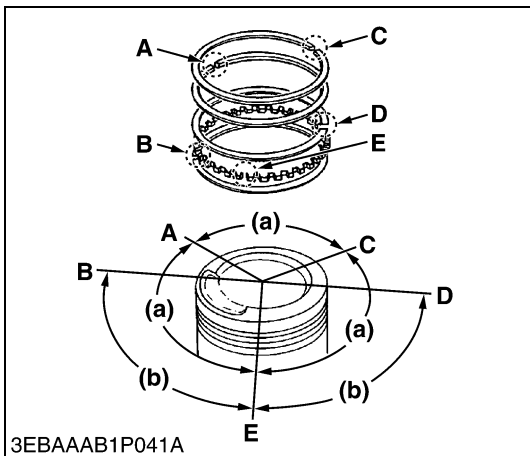
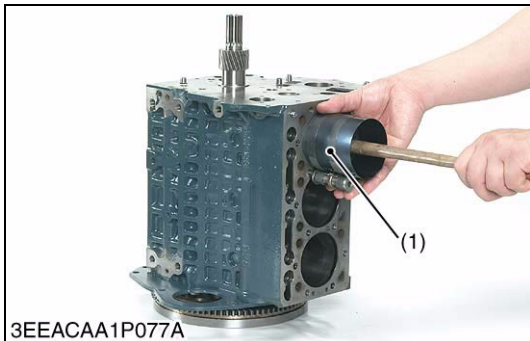
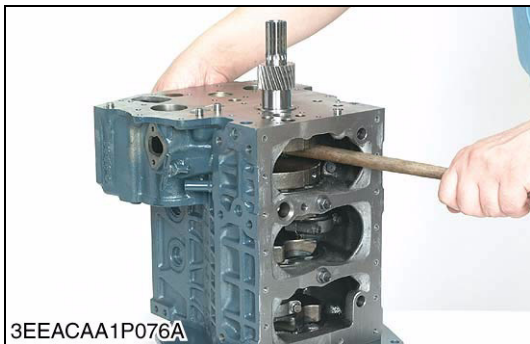

3EBAAAB1P041A

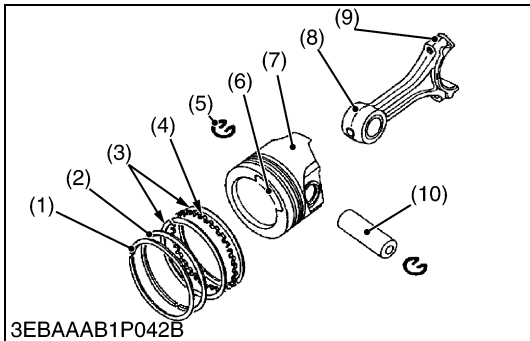

3EBAAAB1P042B

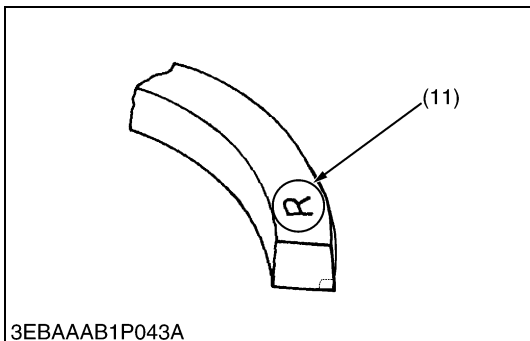

3EBAAAB1P043A

Piston

1. Turn the flywheel and bring the piston to top dead center.
2. Draw out the piston upward by lightly tapping it from the bottom of the crankcase with the grip of a hammer.
3. Draw out the other pistons after the same method as above.

(When reassembling)

- Before inserting the piston into the cylinder, apply enough engine oil to the piston.
- When inserting the piston into the cylinder, face the mark on the connecting rod to the fuel camshaft.
- When inserting the piston into the cylinder, place the gap "C" of the top compression ring on the opposite side of the slant portion, and stagger the gaps "A", "E" of the second compression ring and spacer making 2.09 rad (120 °) from the gap of the top compression ring. Further, stagger the gaps "D", "B" of the upper and lower side rail making 1.6 rad (90 °) from the gap of the spacer.

■ IMPORTANT

- Do not change the combination of cylinder and piston. Make sure of the position of each piston by marking. For example, mark "1" on the No. 1 piston.
- When installing the piston into the cylinder, place the gaps of all of the piston rings as shown in the figure.
- Carefully insert the piston using a piston ring compressor (1). Otherwise, their chrome-plated section may be scratched, causing trouble inside the cylinder.

- | | |
|----------------------------|-------------------|
| (1) Piston Ring Compressor | D : Side Rail Gap |
| | E : Spacer Gap |

- | | |
|---------------------------------|----------------------|
| A : Second Compression Ring Gap | (a) 2.09 rad (120 °) |
| B : Side Rail Gap | (b) 1.6 rad (90 °) |
| C : Top Compression Ring Gap | |

9Y1210318ENS0078US0

Piston Ring and Connecting Rod

1. Remove the piston rings using a piston ring tool.
2. Remove the piston pin (10), and separate the connecting rod (8) from the piston (7).

(When reassembling)

- When installing the second compression ring (2), assemble the rings so that the manufacturer's mark (11) near the gap faces the top of the piston.
- Apply engine oil to the piston pin.
- When installing the connecting rod to the piston, immerse the piston in 80 °C (176 °F) oil for 10 to 15 minutes and insert the piston pin to the piston.
- When installing the connecting rod to the piston, align the mark (9) on the connecting rod to the plug recess (6).

■ IMPORTANT

- Mark the same number on the connecting rod and the piston so as not to change the combination.

- | | |
|--------------------------|--------------------------|
| (1) Top Ring | (7) Piston |
| (2) Second Ring | (8) Connecting Rod |
| (3) Side Rail | (9) Mark |
| (4) Spacer | (10) Piston Pin |
| (5) Piston Pin Snap Ring | (11) Manufacturer's Mark |
| (6) Plug Recess | |

9Y1210318ENS0079US0

(7) Crankshaft

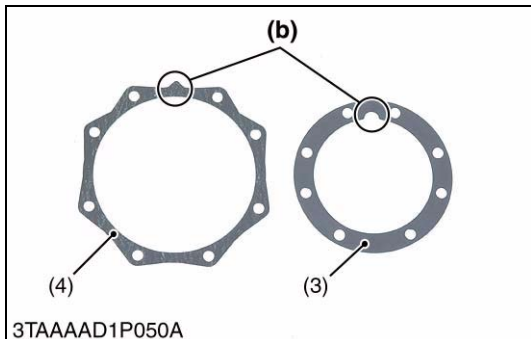
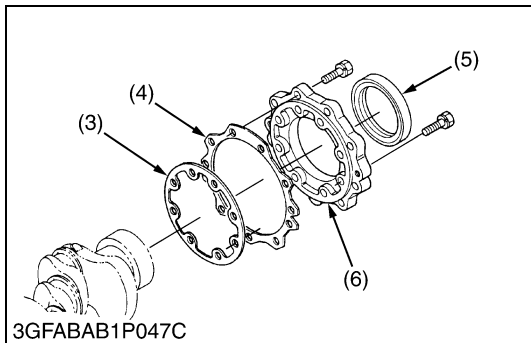
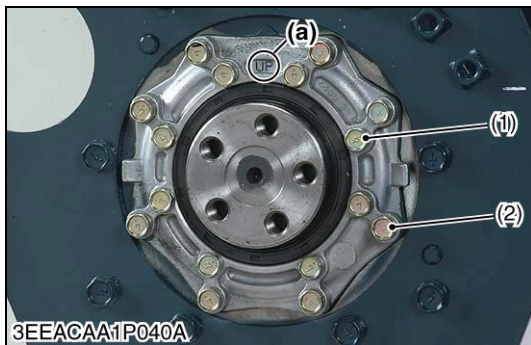
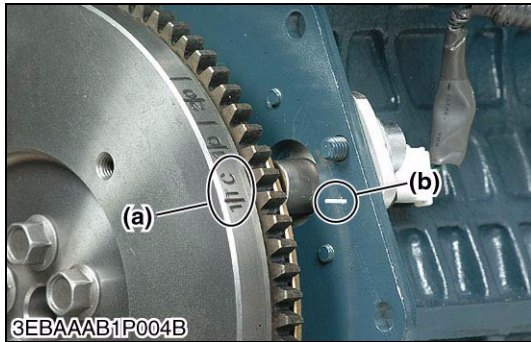
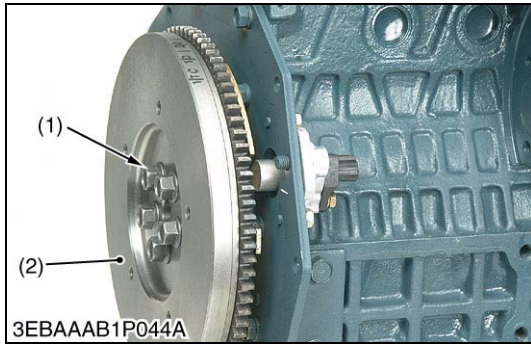

Flywheel

1. Secure the flywheel to keep it from turning using a flywheel stopper.
2. Remove all flywheel screws (1) and then remove the flywheel (2).

(When reassembling)

- Align the "1TC" mark (a) on the outer surface of the flywheel horizontally with the alignment mark (b) on the rear end plate. Now fit the flywheel in position.
- Apply engine oil to the threads and the undercut surface of the flywheel screw and fit the screw.

Tightening torque	Flywheel screw	54 to 58 N·m 5.5 to 6.0 kgf·m 40 to 43 lbf·ft
-------------------	----------------	---

- (1) Flywheel Screw
- (2) Flywheel

- (a) 1TC Mark
- (b) Alignment Mark

9Y1210318ENS0080US0

Bearing Case Cover

1. Remove the bearing case cover mounting screws. First, remove inside screws (1) and then outside screws (2).
2. Remove the bearing case cover (6).

(When reassembling)

- Fit the bearing case gasket (3) and the bearing case cover gasket (4) with correct directions.
- Install the bearing case cover (6) to position the casting mark "UP" (a) on it upward.
- Apply engine oil to the oil seal (5) lip and take care that it is not rolled when installing.
- Tighten the bearing case cover mounting screws with even force on the diagonal line.

Tightening torque	Bearing case cover mounting screw	9.81 to 11.2 N·m 1.00 to 1.15 kgf·m 7.24 to 8.31 lbf·ft
-------------------	-----------------------------------	---

- (1) Bearing Case Cover Mounting Screw (Inside)
- (2) Bearing Case Cover Mounting Screw (Outside)
- (3) Bearing Case Gasket
- (4) Bearing Case Cover Gasket

- (5) Oil Seal
- (6) Bearing Case Cover
- (a) Top Mark "UP"
- (b) Upside

9Y1210318ENS0081US0

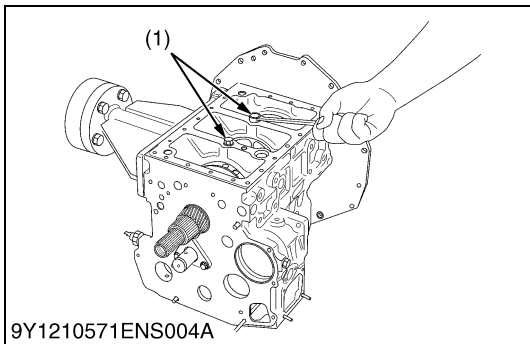

Crankshaft Assembly (WG752-G/GL-E3)

1. Remove the main bearing case screw 2 (1).
2. Pull out the crankshaft assembly

■ **IMPORTANT**

- Take care to protect crankshaft bearing 1 from scratches, caused by the crank shaft, etc.

(When reassembling)

- Clean the oil passage of the crankshaft with compressed air.
- Apply oil to the main bearing case screw 2 (1).
- Install the crankshaft assembly, aligning the screw hole of main bearing case with the screw hole of crankcase.
- Clean the oil passage of the crankshaft with compressed air.

Tightening torque	Main bearing case screw 2	27 to 30 N·m 2.7 to 3.1 kgf·m 20 to 22 lbf·ft
-------------------	---------------------------	---

(1) Main Bearing Case Screw 2

9Y1210571ENS0033US0

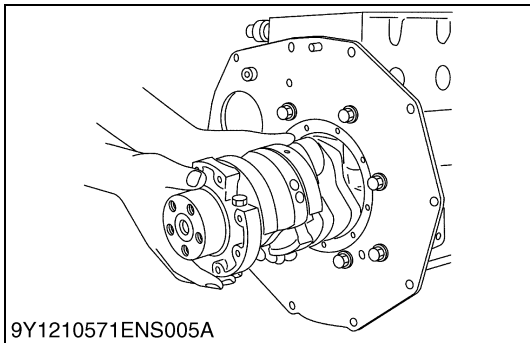

Crankshaft Assembly (WG972-G/GL-E3)

1. Remove the main bearing case screw 2 (1).
2. Turn the crankshaft to set the crankpin of the third cylinder to the bottom dead center. Then draw out the crankshaft until the crankpin of the second cylinder comes to the center of the third cylinder.
3. Turn the crankshaft by 2.09 rad (120 °) counterclockwise to set the crankpin of the second cylinder to the bottom dead center. Draw out the crankshaft until the crankpin of the first cylinder comes to the center of the third cylinder.
4. Repeat the above steps to draw out all the crankshaft.

(When reassembling)

- Clean the oil passage of the crankshaft with compressed air.
- Install the crankshaft assembly, aligning the screw hole of main bearing case screw 2 with the screw hole of crankcase.
- When tightening the main bearing case screw 2, apply oil to the main bearing case screw 2 (1) and screw by hand before tightening the specific torque. If not smooth to screw by hand, align the screw holes between the crankcase and the main bearing case.

Tightening torque	Main bearing case screw 2	27 to 30 N·m 2.7 to 3.1 kgf·m 20 to 22 lbf·ft
-------------------	---------------------------	---

(1) Main Bearing Case Screw 2

(a) Cut Place for Removing and Installing the Crankshaft

9Y1210571ENS0032US0

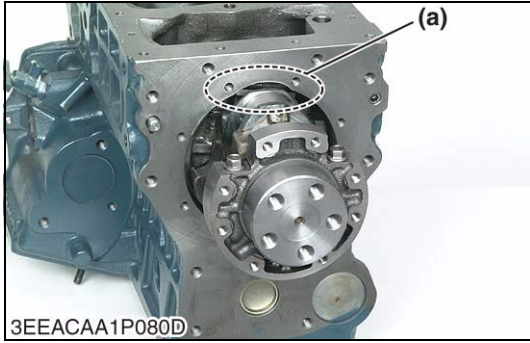
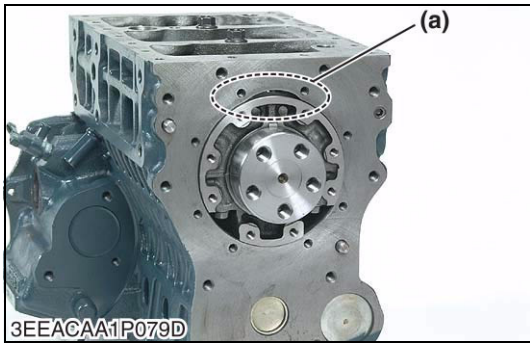
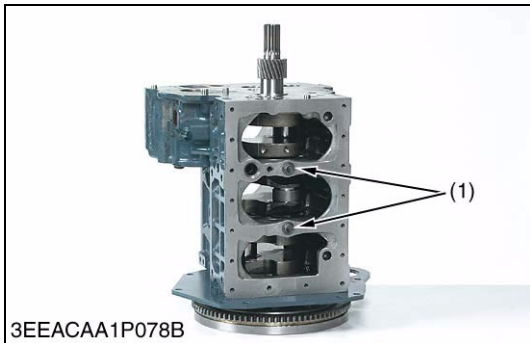

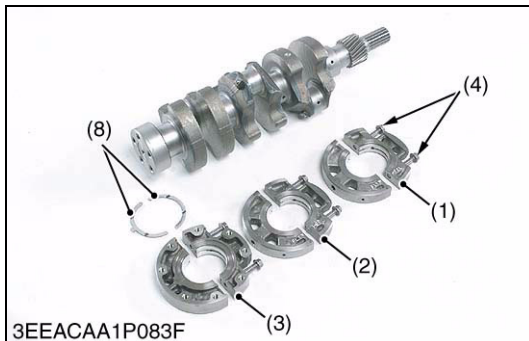
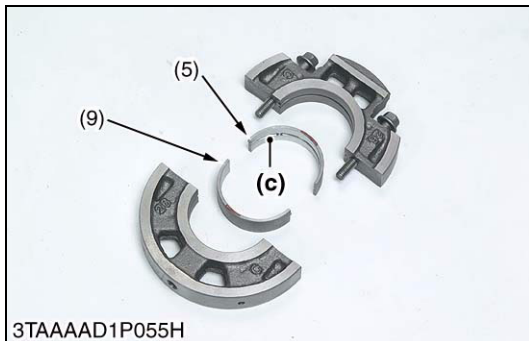
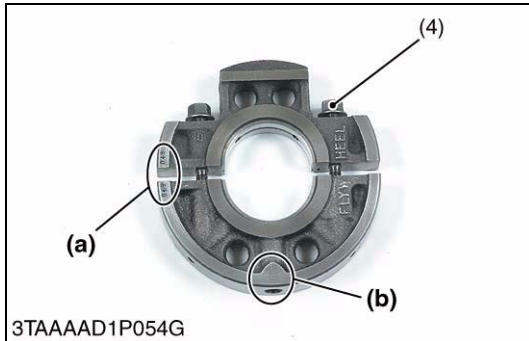
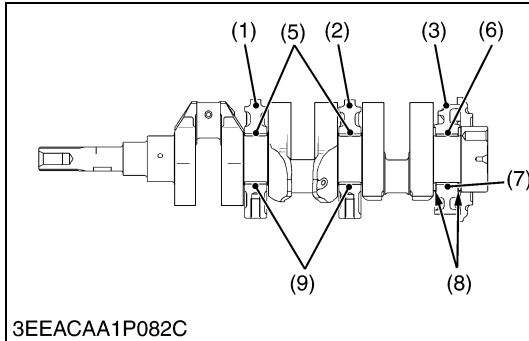
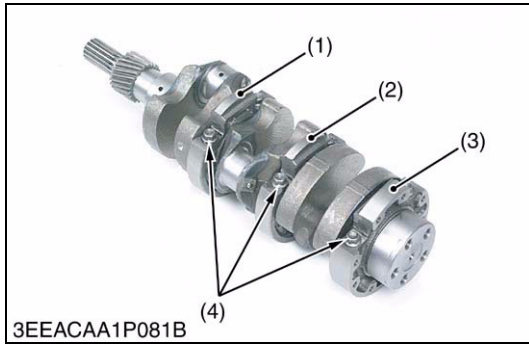

Main Bearing Case Assembly

1. Remove the two main bearing case screws 1 (4), and remove the main bearing case assembly 1 (1), being careful with crankshaft bearing 3 (5) (9).
2. Remove the main bearing case assembly 2 (2) and the main bearing case assembly (3) as above. Keep in mind, however, that the thrust bearing (8) is installed in the main bearing case assembly (3).

(When reassembling)

- Clean the oil passage in the main bearing cases.
- Apply clean engine oil to the bearings.
- Install the main bearing case assemblies in original positions. Since diameters of main bearing cases vary, install them in order of marking **(b)** from the gear case side. (Refer to the figure.)
- Be careful not to confuse the top and bottom of the crankshaft bearing 3 (5) (9). (Install the bearing with the oil groove **(c)** up.)
- Match the alignment numbers **(a)** on the main bearing case assembly 1.
- Do the same for the main bearing case assembly 2 (2) and the main bearing case assembly (3) too.
- When installing the main bearing case 1 and 2, face the mark **"FLYWHEEL"** to the flywheel.
- Install the thrust bearing (8) with its oil groove facing outward.
- Confirm that the main bearing case moves smoothly after tightening the main bearing case screw 1 to the specified torque.

Tightening torque	Main bearing case screw 1	13 to 15 N·m 1.3 to 1.6 kgf·m 9.4 to 11 lbf·ft
-------------------	---------------------------	--

- (1) Main Bearing Case Assembly 1 **(a) Alignment Number**
- (2) Main Bearing Case Assembly 2 **(b) Marking (1 or 2)**
- (3) Main Bearing Case Assembly **(c) Oil Groove**
- (4) Main Bearing Case Screw 1
- (5) Crankshaft Bearing 3 (Upper, with Oil Groove)
- (6) Crankshaft Bearing 2 (Upper, with Oil Groove)
- (7) Crankshaft Bearing 2 (Lower)
- (8) Thrust Bearing
- (9) Crankshaft Bearing 3 (Lower)

9Y1210318ENS0083US0

(8) Starter

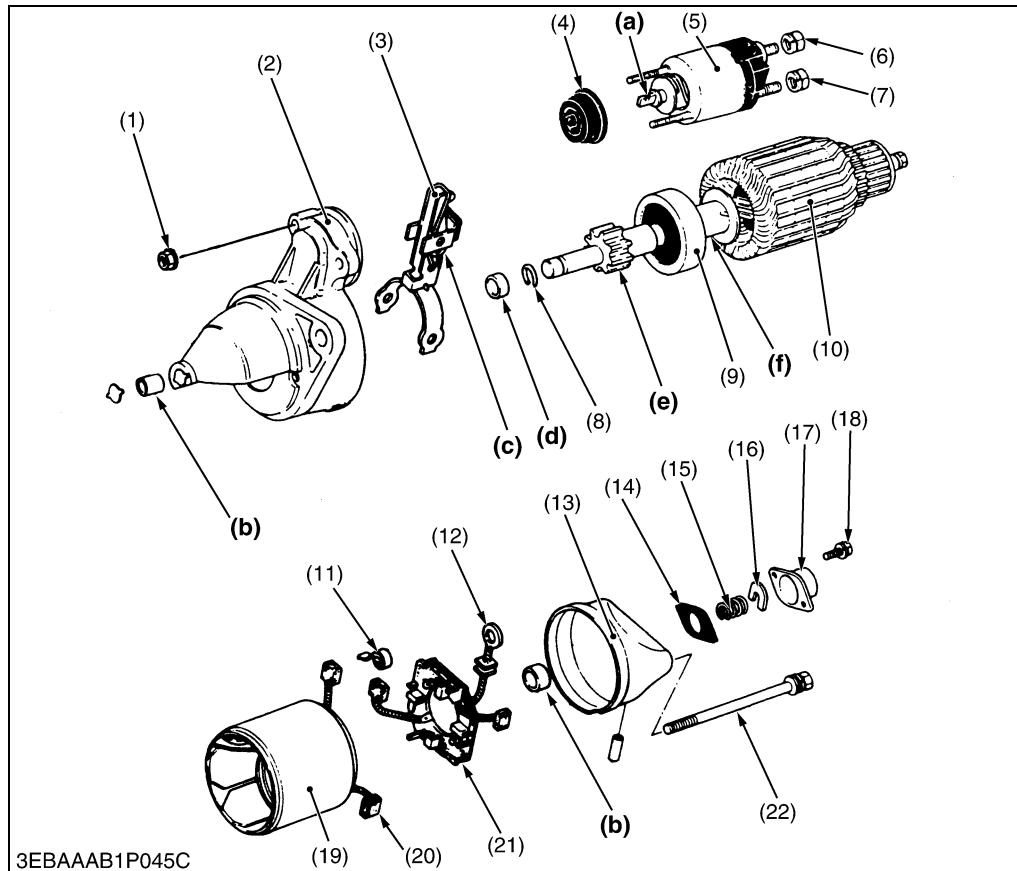

- (1) Solenoid Switch Mounting Nut
- (2) Starter Drive Housing
- (3) Drive Lever
- (4) Gasket
- (5) Solenoid Switch
- (6) **B** Terminal Nut
- (7) **C** Terminal Nut
- (8) Snap Ring
- (9) Overrunning Clutch
- (10) Armature
- (11) Brush Spring
- (12) Connecting Lead
- (13) Rear End Frame
- (14) Gasket
- (15) Brake Spring
- (16) Brake Shoe
- (17) End Frame Cap
- (18) Screw
- (19) Yoke
- (20) Brush
- (21) Brush Holder
- (22) Through Bolt

1. Unscrew the **C** terminal nut (7), and disconnect the connecting lead (12).
2. Unscrew the solenoid switch mounting nuts (1), and remove the solenoid switch (5).
3. Remove the end frame cap (17).
4. Remove the brake shoe (16), brake spring (15) and gasket (14).
5. Unscrew the through bolts (22), and remove the rear end frame (13).
6. Remove the brush from the brush holder while holding the spring up.
7. Remove the brush holder (21).
8. Draw out the yoke (19) from the starter drive housing (2).
9. Draw out the armature (10) with the drive lever (3).

■ **NOTE**

- **Do not damage to the brush and commutator.**

(When reassembling)

- Apply grease (DENSO.CO.LTD. No. 50 or equivalent) to the parts indicated in the figure.
 - Joint of solenoid switch **(a)**
 - Bushing **(b)**
 - Drive lever **(c)**
 - Collar **(d)**
 - Teeth of pinion gear **(e)**
 - Armature shaft **(f)**

Tightening torque	Starter's terminal B mounting nut	5.9 to 11 N·m 0.60 to 1.2 kgf·m 4.4 to 8.6 lbf·ft
-------------------	--	---

9Y1210318ENS0084US0

(9) Dynamo

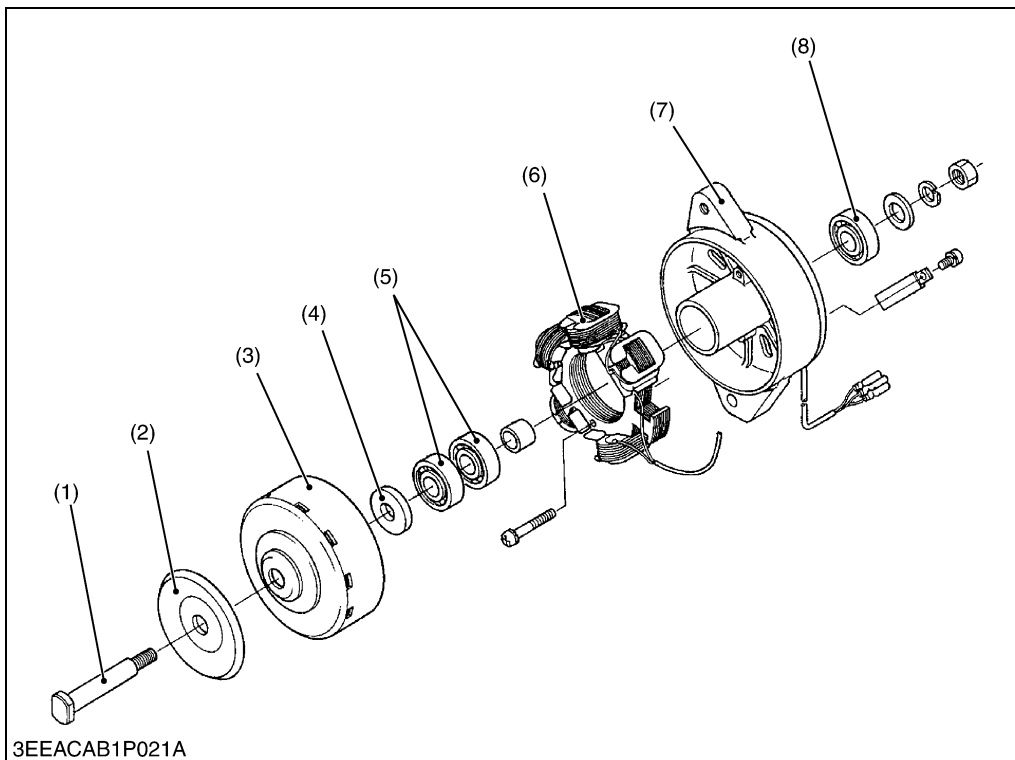

- (1) Shaft
- (2) Pulley
- (3) Rotor
- (4) Collar
- (5) Bearing
- (6) Stator
- (7) Plate
- (8) Bearing

1. Remove the nut and separate the plate (7).
2. Tap out the shaft (1) from the rotor (3).
3. Unscrew the screws and remove the stator (6).

(When reassembling)

- Take care the direction of the collar (4), the flat side should face to the pulley side.

Tightening torque	Dynamo's pulley nut	39.2 to 44.1 N·m 4.00 to 4.49 kgf·m 29.0 to 32.5 lbf·ft
-------------------	---------------------	---

9Y1210571ENS0034US0

(10) Alternator

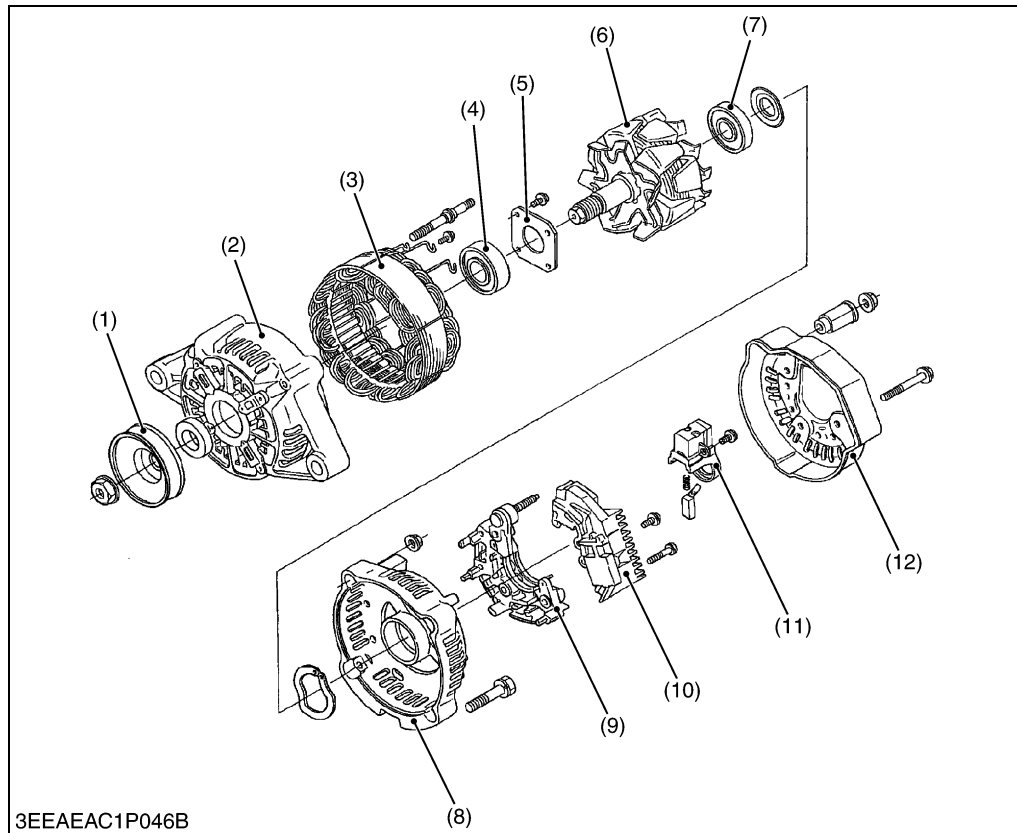

- (1) Pulley
- (2) Drive End Frame
- (3) Stator
- (4) Bearing
- (5) Retainer Plate
- (6) Rotor
- (7) Bearing
- (8) Rear End Frame
- (9) Rectifier
- (10) IC Regulator
- (11) Brush Holder
- (12) Rear End Cover

1. Remove the pulley (1).
2. Remove the rear end cover (12).
3. Remove the brush holder (11).
4. Remove the IC regulator (10).
5. Remove the four screws holding the stator lead wires.
6. Remove the rectifier (9).
7. Remove the rear end frame (8).
8. Press out the rotor (6) from drive end frame (2).
9. Remove the retainer plate (5).
10. Press out the bearing (4) from drive end frame (2) with a press and jig.
11. Lightly secure the rotor with a vise to prevent damage, and remove the bearing (7) with a puller.

(When reassembling)

Tightening torque	Alternator's pulley nut	58.4 to 78.9 N·m 5.95 to 8.05 kgf·m 43.1 to 58.2 lbf·ft
-------------------	-------------------------	---

9Y1210318ENS0086US0

[3] SERVICING

(1) Combustion Chamber



Cleaning Combustion Chamber

Clean any carbon deposits from the combustion chamber walls including the cylinder head surface, surroundings of valve tops, and piston top surfaces. Check valve seating according to following section, and carry out valve seat grinding if necessary.

9Y1210571ENS0069US0

(2) Cylinder Head and Valves

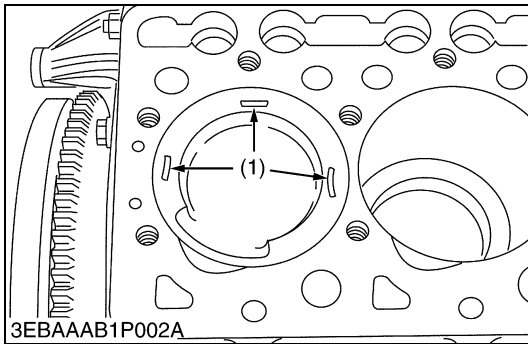

3EBAAAB1P002A

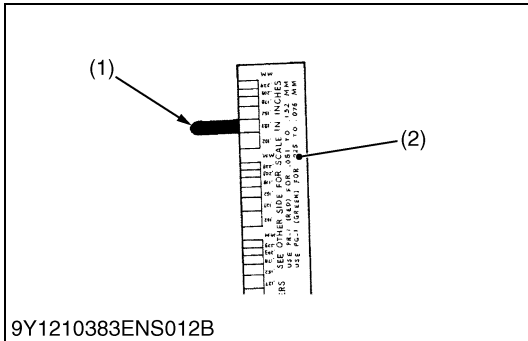

9Y1210383ENS012B

Top Clearance

1. Remove the cylinder head.
2. With the piston at TDC, use grease to affix three or four plastigauges of a diameter 1.5 mm (0.059 in.) x 5.0 to 7.0 mm (0.20 to 0.27 in.) long to the crown of the piston; keep the gauges away from the intake valve and combustion chamber fittings.
3. Take the piston to an intermediate position, install the cylinder head and tighten the head bolts to the specified torque.
4. Turn the crankshaft so the piston goes through TDC.
5. Remove the cylinder head and measure the thickness of the plastigauges.
6. If they are out of spec, check the oil clearance of the crank pin journal and piston pins.

[WG752-G/GL-E3]

Top clearance	Factory specification	1.45 to 1.75 mm 0.0571 to 0.0688 in.
---------------	-----------------------	---

Tightening torque	Cylinder head screws	38 to 42 N·m 3.8 to 4.3 kgf·m 28 to 31 lbf·ft
-------------------	----------------------	---

[WG972-G/GL-E3]

Top clearance	Factory specification	1.35 to 1.65 mm 0.0532 to 0.0649 in.
---------------	-----------------------	---

Tightening torque	Cylinder head screws	40 to 44 N·m 4.0 to 4.5 kgf·m 29 to 32 lbf·ft
-------------------	----------------------	---

(1) Plastigauge

(2) Scale

9Y1210571ENS0009US0

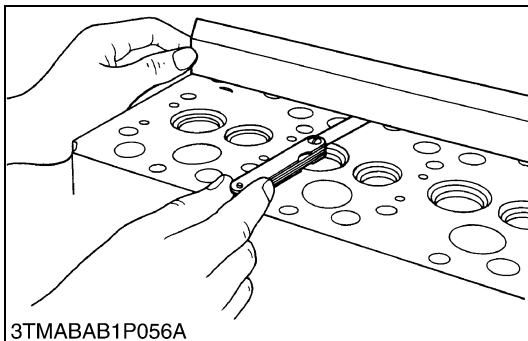

3TMABAB1P056A

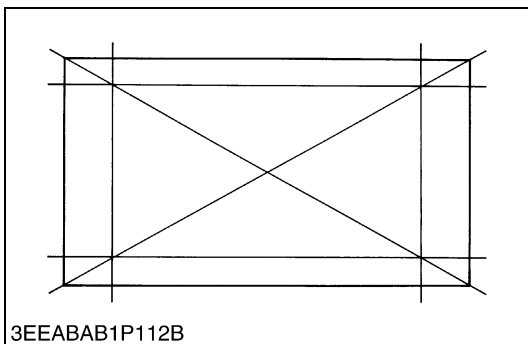

3EEABAB1P112B

Cylinder Head Surface Flatness

1. Clean the cylinder head surface.
2. Place a straightedge on the cylinder head's four sides and two diagonal as shown in the figure. Measure the clearance with a feeler gauge.
3. If the measurement exceeds the allowable limit, correct it with a surface grinder.

■ IMPORTANT

- Be sure to check the valve recessing after correcting.

Cylinder head surface flatness	Allowable limit	0.05 mm 0.002 in.
--------------------------------	-----------------	----------------------

9Y1210318ENS0087US0

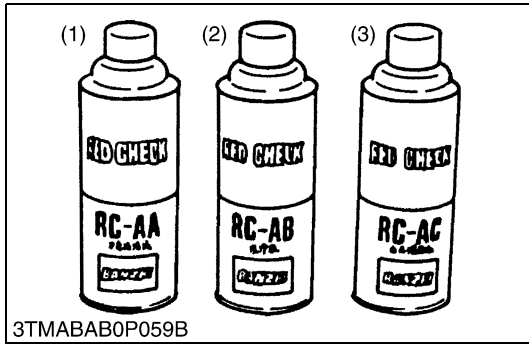

Cylinder Head Flaw

1. Prepare an air spray red check.
2. Clean the surface of the cylinder head with the detergent (2).
3. Spray the cylinder head surface with the red permeative liquid (1). Leave it five to ten minutes after spraying.
4. Wash away the red permeative liquid on the cylinder head surface with the detergent (2).
5. Spray the cylinder head surface with the white developer (3).
6. If flawed, it can be identified as red marks.

- (1) Red Permeative Liquid (3) White Developer
 (2) Detergent

9Y1210318ENS0088US0

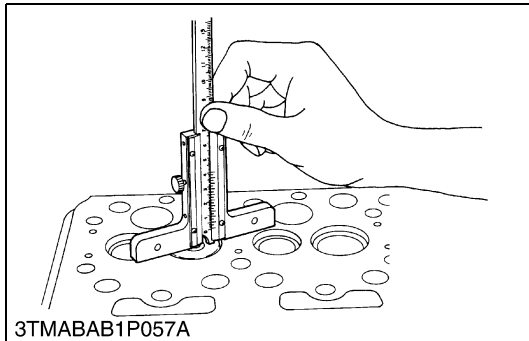

Valve Recessing

1. Clean the cylinder head, the valve face and seat.
2. Insert the valve into the valve guide.
3. Measure the valve recessing with a depth gauge.
4. If the measurement exceeds the allowable limit, replace the valve.
5. If it still exceeds the allowable limit after replacing the valve, replace the cylinder head.

Valve recessing (Intake and Exhaust)	Factory specification	0.10 (protrusion) to 0.10 (recessing) mm 0.0039 (protrusion) to 0.0039 (recessing) in.
	Allowable limit	0.30 (recessing) mm 0.012 (recessing) in.

- (1) Cylinder Head Surface (A) Recessing (B) Protrusion

9Y1210318ENS0089US0

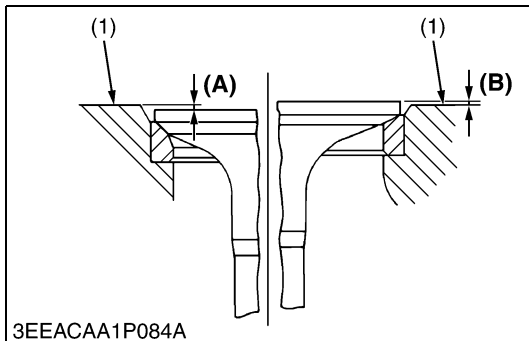

Valve Seating

1. Coat the valve face lightly with prussian blue and put the valve on its seat to check the contact.
2. If the valve does not seat all the way around the valve seat or the valve contact is less than 70 %, correct the valve seating as follows.
3. If the valve contact does not comply with the reference value, replace the valve or correct the contact of valve seating.

Valve seat width	Factory specification	2.12 mm 0.0835 in.
------------------	-----------------------	-----------------------

- (1) Correct (3) Incorrect
 (2) Incorrect

9Y1210318ENS0092US0

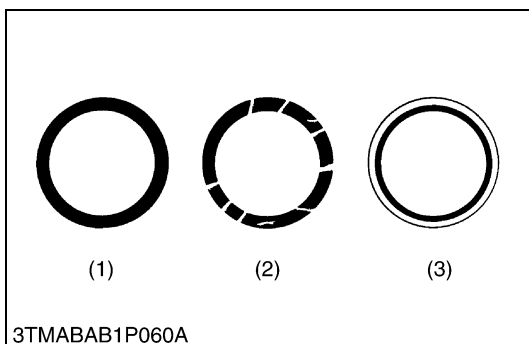
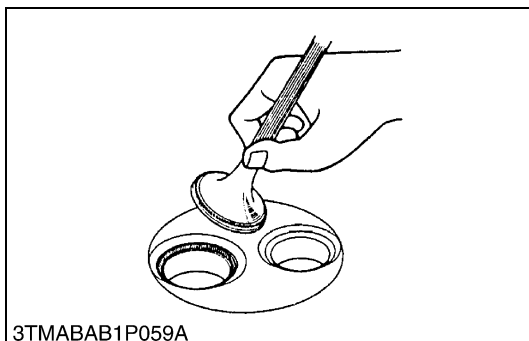

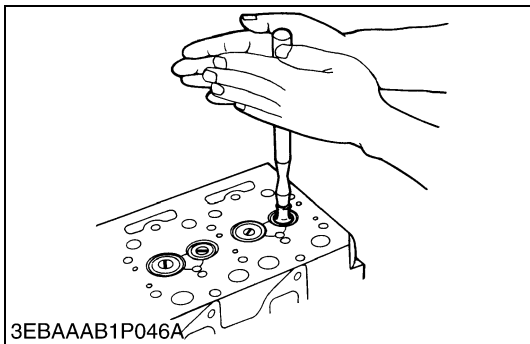

3EBAAAB1P046A

Valve Lapping

1. Apply compound evenly to the valve lapping surface.
2. Insert the valve into the valve guide. Lap the valve onto its seat with a valve flapper or screwdriver.
3. After lapping the valve, wash the compound away and apply oil, then repeat valve lapping with oil.
4. Apply prussian blue to the contact surface to check the seated rate. If it is less than 70 %, repeat valve lapping again.

■ **IMPORTANT**

- **When valve lapping is performed, be sure to check the valve recessing and adjust the valve clearance after assembling the valve.**

9Y1210318ENS0094US0

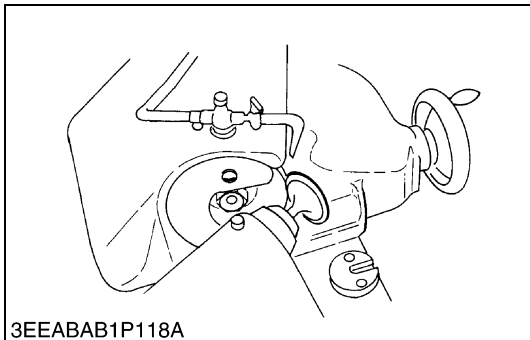

3EEABAB1P118A

Correcting Valve and Valve Seat

■ **NOTE**

- **Before correcting the valve and seat, check the valve stem and the I.D. of valve guide section, and repair them if necessary.**
- **After correcting the valve seat, be sure to check the valve recessing.**

1) Correcting Valve

1. Correct the valve with a valve refacer.

Valve face angle	Factory specification	0.79 rad 45 °
------------------	-----------------------	------------------

2) Correcting Valve Seat

1. Slightly correct the seat surface with a 0.79 rad (45 °) valve seat cutter.
2. Fitting the valve, check the contact position of the valve face and seat surface with prussian blue. (Visual check) [If the valve has been used for a long period, the seat tends to come in contact with the upper side of the valve face.]
3. Grind the upper surface of the seat with a 0.26 rad (15 °) valve seat cutter until the valve seat touches to the center of the valve face (so that (a) equals (b) as shown in the figure.)
4. Grind the seat with a 0.79 rad (45 °) valve seat cutter again, and visually recheck the contact between the valve and seat.
5. Repeat steps 3 and 4 until the correct contact is achieved.
6. Continue lapping until the seated rate becomes more than 70 % of the total contact.

Valve seat angle	Factory specification	0.79 rad 45 °
------------------	-----------------------	------------------

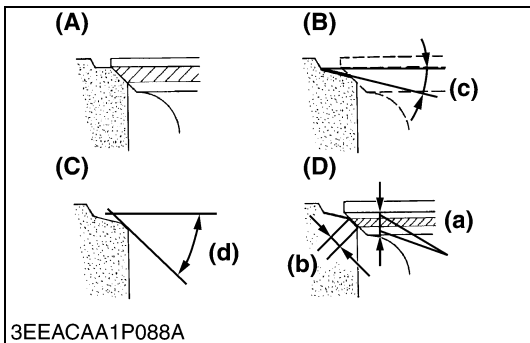

3EEACAA1P088A

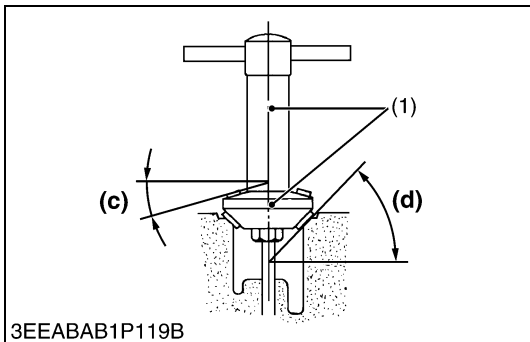

3EEABAB1P119B

- | | |
|------------------------|--------------------------|
| (1) Valve Seat Cutter | (a) Identical Dimensions |
| (A) Check Contact | (b) Valve Seat Width |
| (B) Correct Seat Width | (c) 0.26 rad (15 °) |
| (C) Check Seat Surface | (d) 0.79 rad (45 °) |
| (D) Check Contact | |

9Y1210318ENS0093US0

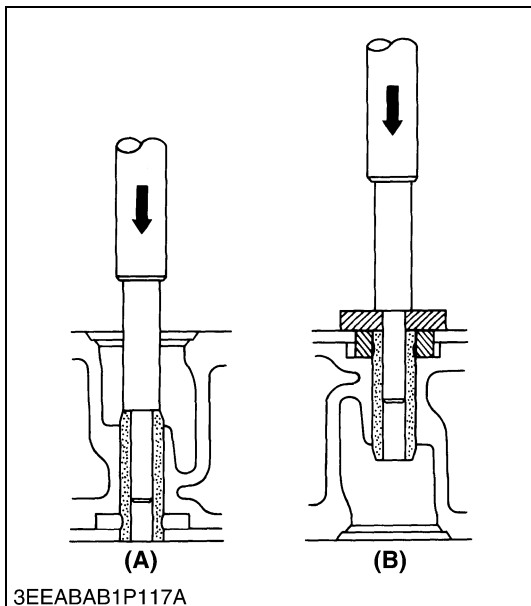
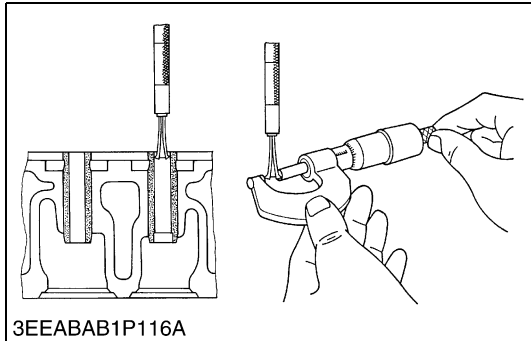
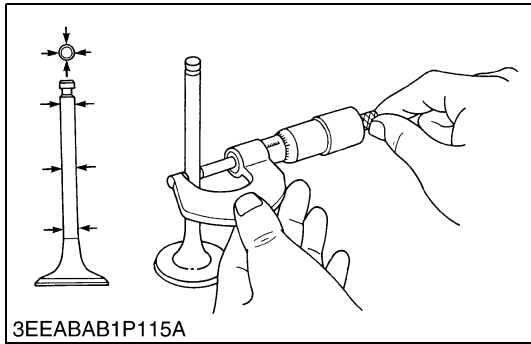

Clearance between Valve Stem and Valve Guide

1. Remove carbon from the valve guide section.
2. Measure the valve stem O.D. with an outside micrometer.
3. Measure the valve guide I.D. with a small hole gauge, and calculate the clearance.
4. If the clearance exceeds the allowable limit, replace the valves. If it still exceeds the allowable limit, replace the valve guide.

Clearance between valve stem and valve guide	Factory specification	0.030 to 0.057 mm 0.0012 to 0.0022 in.
	Allowable limit	0.10 mm 0.0039 in.

Valve stem O.D.	Factory specification	5.968 to 5.980 mm 0.2350 to 0.2354 in.
Valve guide I.D.	Factory specification	6.010 to 6.025 mm 0.2367 to 0.2372 in.

9Y1210318ENS0090US0

Replacing Valve Guide

(When removing)

1. Press out the used valve guide using a valve guide replacing tool.

(When installing)

1. Clean a new valve guide and valve guide bore, and apply engine oil to them.
2. Press in a new valve guide using a valve guide replacing tool.
3. Ream precisely the I.D. of the valve guide to the specified dimension.

Valve guide I.D.(Intake and exhaust)	Factory specification	6.010 to 6.025 mm 0.2367 to 0.2372 in.
--------------------------------------	-----------------------	---

■ IMPORTANT

- Do not hit the valve guide with a hammer during replacement.

(A) When Removing

(B) When Installing

9Y1210318ENS0091US0

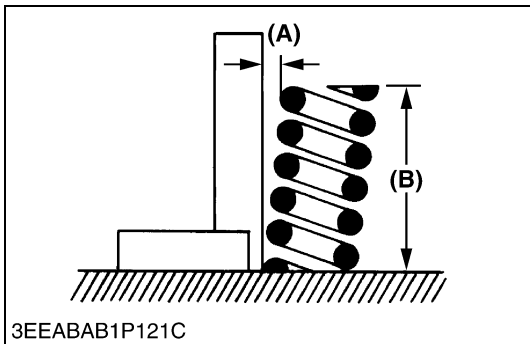

3EEABAB1P121C

Free Length and Tilt of Valve Spring

1. Measure the free length **(B)** of valve spring with vernier calipers. If the measurement is less than the allowable limit, replace it.
2. Put the spring on a surface plate, place a square on the side of the spring.
3. Check to see if the entire side is in contact with the square. Rotate the valve spring and measure the maximum tilt **(A)**. If the measurement exceeds the allowable limit, replace it.
4. Check the entire surface of the valve spring for scratches. If there is any defect, replace it.

Tilt (A)	Allowable limit	1.2 mm 0.047 in.
-----------------	-----------------	---------------------

Free length (B)	Factory specification	31.3 to 31.8 mm 1.24 to 1.25 in.
	Allowable limit	28.4 mm 1.12 in.

(A) Tilt

(B) Free length

9Y1210571ENS0037US0

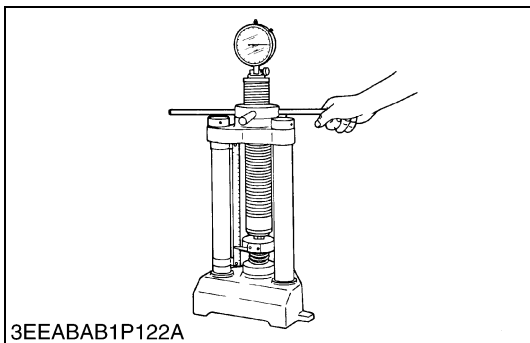

3EEABAB1P122A

Valve Spring Setting Load

1. Place the valve spring on a tester and compress it to the same length it is actually compressed in the engine.
2. Read the compression load on the gauge.
3. If the measurement is less than the allowable limit, replace it.

Setting load / setting length	Factory specification	65 N / 27.0 mm 6.6 kgf / 27.0 mm 15 lbf / 1.06 in.
	Allowable limit	55 N / 27.0 mm 5.6 kgf / 27.0 mm 12 lbf / 1.06 in.

9Y1210318ENS0096US0



3TAAAD1P060A

Oil Clearance between Rocker Arm and Rocker Arm Shaft

1. Measure the rocker arm shaft O.D. with an outside micrometer.
2. Measure the rocker arm I.D. with an inside micrometer, and then calculate the oil clearance.
3. If the oil clearance exceeds the allowable limit, replace the rocker arm and measure the oil clearance again. If it still exceeds the allowable limit, replace also the rocker arm shaft.

Oil clearance between rocker arm and rocker arm shaft	Factory specification	0.016 to 0.045 mm 0.00063 to 0.0017 in.
	Allowable limit	0.15 mm 0.0059 in.

Rocker arm shaft O.D.	Factory specification	10.473 to 10.484 mm 0.41233 to 0.41275 in.
-----------------------	-----------------------	---

Rocker arm I.D.	Factory specification	10.500 to 10.518 mm 0.41339 to 0.41409 in.
-----------------	-----------------------	---

9Y1210318ENS0097US0

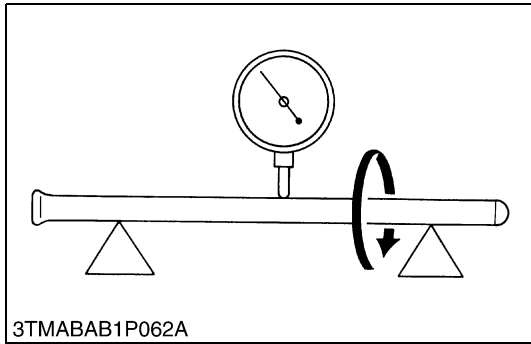

3TMABAB1P062A

Push Rod Alignment

1. Place the push rod on V blocks.
2. Measure the push rod alignment.
3. If the measurement exceeds the allowable limit, replace the push rod.

Push rod alignment	Allowable limit	0.25 mm 0.0098 in.
--------------------	-----------------	-----------------------

9Y1210318ENS0098US0

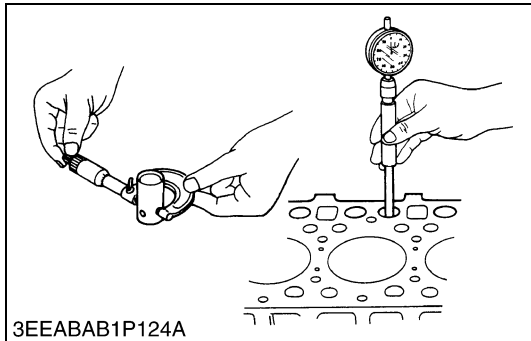

3EEABAB1P124A

Oil Clearance between Tappet and Tappet Guide Bore

1. Measure the tappet O.D. with an outside micrometer.
2. Measure the I.D. of the tappet guide bore with a cylinder gauge, and calculate the oil clearance.
3. If the oil clearance exceeds the allowable limit or the tappet is damaged, replace the tappet.

Oil clearance between tappet and tappet guide bore	Factory specification	0.016 to 0.052 mm 0.00063 to 0.0020 in.
	Allowable limit	0.10 mm 0.0039 in.

Tappet O.D.	Factory specification	17.966 to 17.984 mm 0.70733 to 0.70803 in.
Tappet guide bore I.D.	Factory specification	18.000 to 18.018 mm 0.70867 to 0.70937 in.

9Y1210318ENS0099US0

(3) Timing Gear and Camshaft

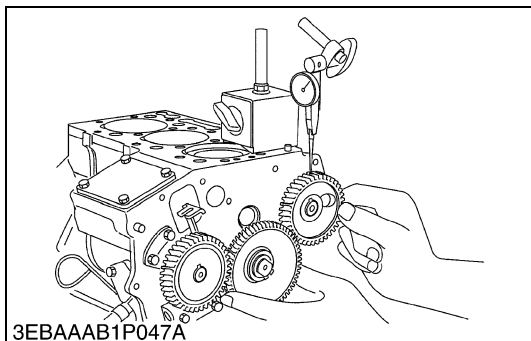

3EBAAAB1P047A

Timing Gear Backlash

1. Set a dial indicator (lever type) with its tip on the gear tooth.
2. Move the gear to measure the backlash, holding its mating gear.
3. If the backlash exceeds the allowable limit, check the oil clearance of the shafts and the gear.
4. If the oil clearance is proper, replace the gear.

Backlash between idle gear and crank gear	Factory specification	0.0430 to 0.124 mm 0.00170 to 0.00488 in.
	Allowable limit	0.15 mm 0.0059 in.

Backlash between idle gear and cam gear	Factory specification	0.0470 to 0.123 mm 0.00185 to 0.00484 in.
	Allowable limit	0.15 mm 0.0059 in.

Backlash between idle gear and injection pump gear	Factory specification	0.0410 to 0.124 mm 0.00162 to 0.00488 in.
	Allowable limit	0.15 mm 0.0059 in.

Backlash between oil pump drive gear and crank gear	Factory specification	0.0410 to 0.123 mm 0.00162 to 0.00484 in.
	Allowable limit	0.15 mm 0.0059 in.

9Y1210318ENS0100US0

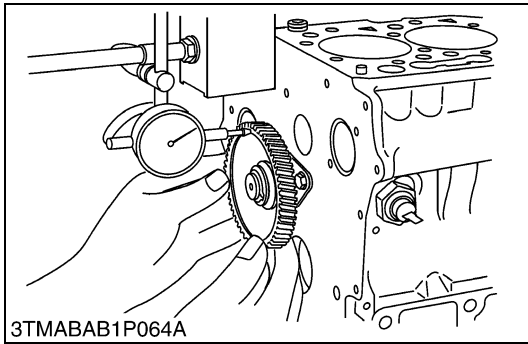

Idle Gear Side Clearance

1. Set a dial indicator with its tip on the idle gear.
2. Measure the side clearance by moving the idle gear to the front and rear.
3. If the measurement exceeds the allowable limit, replace the idle gear collar.

[WG752-G/GL-E3]

Idle gear side clearance	Factory specification	0.20 to 0.46 mm 0.0079 to 0.018 in.
	Allowable limit	0.60 mm 0.024 in.

[WG972-G/GL-E3]

Idle gear side clearance	Factory specification	0.20 to 0.51 mm 0.0079 to 0.020 in.
	Allowable limit	0.80 mm 0.031 in.

9Y1210318ENS0101US0

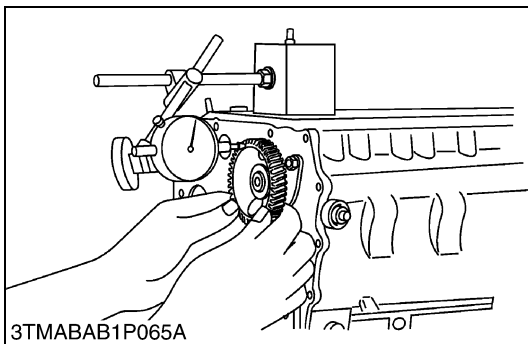

Camshaft Side Clearance

1. Set a dial indicator with its tip on the camshaft.
2. Measure the side clearance by moving the cam gear to the front and rear.
3. If the measurement exceeds the allowable limit, replace the camshaft stopper.

Camshaft side clearance	Factory specification	0.15 to 0.31 mm 0.0059 to 0.012 in.
	Allowable limit	0.50 mm 0.020 in.

9Y1210318ENS0102US0

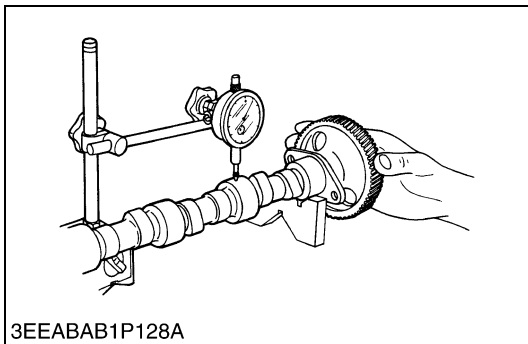

Camshaft Alignment

1. Support the camshaft with V blocks on the surface plate at both end journals.
2. Set a dial indicator with its tip on the intermediate journal.
3. Measure the camshaft alignment.
4. If the measurement exceeds the allowable limit, replace the camshaft.

Camshaft alignment	Allowable limit	0.01 mm 0.0004 in.
--------------------	-----------------	-----------------------

9Y1210318ENS0103US0

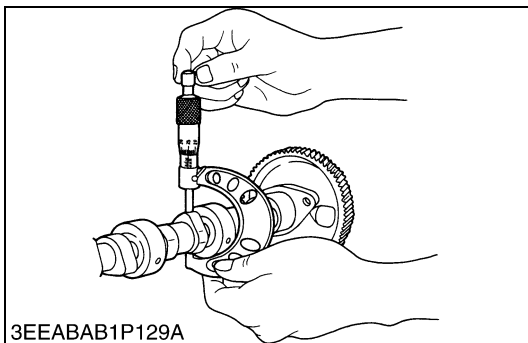

Cam Height

1. Measure the height of the cam at its highest point with an outside micrometer.
2. If the measurement is less than the allowable limit, replace the camshaft.

Cam height of intake and exhaust	Factory specification	26.88 mm 1.058 in.
	Allowable limit	26.83 mm 1.056 in.

9Y1210318ENS0104US0

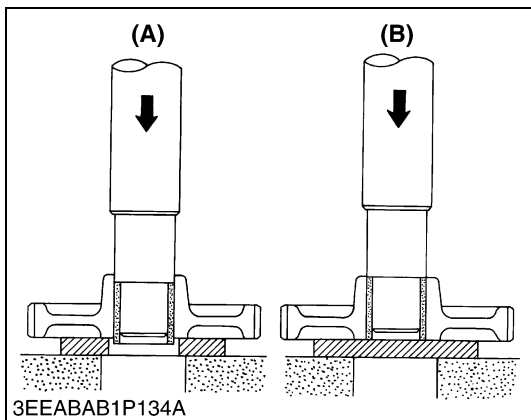
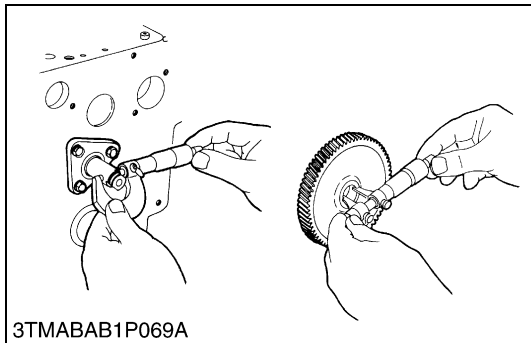
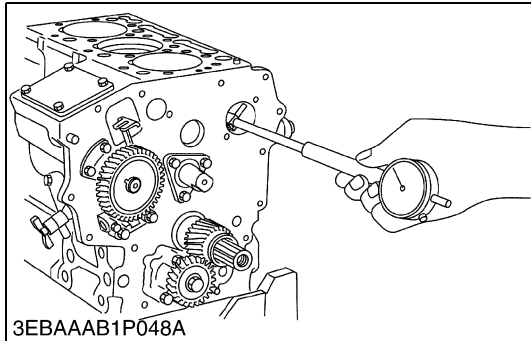
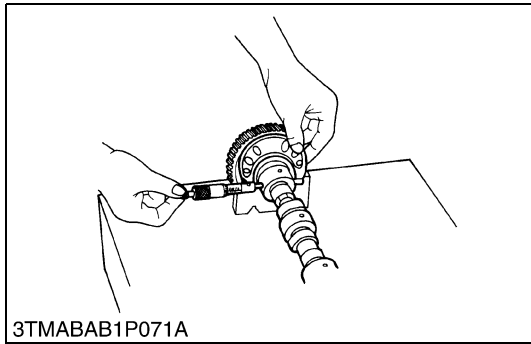

Oil Clearance of Camshaft Journal

1. Measure the camshaft journal O.D. with an outside micrometer.
2. Measure the cylinder block bore I.D. for camshaft with a inside micrometer, and calculate the oil clearance.
3. If the clearance exceeds the allowable limit, replace the camshaft.

Oil clearance of camshaft journal	Factory specification	0.050 to 0.091 mm 0.0020 to 0.0035 in.
	Allowable limit	0.15 mm 0.0059 in.

Camshaft journal O.D.	Factory specification	32.934 to 32.950 mm 1.2967 to 1.2972 in.
Camshaft bearing I.D. (Cylinder block bore I.D.)	Factory specification	33.000 to 33.025 mm 1.2993 to 1.3001 in.

9Y1210318ENS0105US0

Oil Clearance between Idle Gear Shaft and Idle Gear Bushing

1. Measure the idle gear shaft O.D. with an outside micrometer.
2. Measure the idle gear bushings I.D. with an inside micrometer, and calculate the oil clearance.
3. If the oil clearance exceeds the allowable limit, replace the bushing.
4. If it still exceeds the allowable limit, replace the idle gear shaft.

Oil clearance between idle gear shaft and idle gear bushing	Factory specification	0.020 to 0.084 mm 0.00079 to 0.0033 in.
	Allowable limit	0.10 mm 0.0039 in.

Idle gear shaft O.D.	Factory specification	19.967 to 19.980 mm 0.78611 to 0.78661 in.
Idle gear bushing I.D.	Factory specification	20.000 to 20.051 mm 0.78741 to 0.78940 in.

9Y1210318ENS0106US0

Replacing Idle Gear Bushing

(When removing)

1. Press out the used idle gear bushing using an idle gear bushing replacing tool.

(When installing)

1. Clean a new idle gear bushing and idle gear bore, and apply engine oil to them.
2. Press in a new bushing using an idle gear bushing replacing tool, until it is flush with the end of the idle gear.

(A) When Removing

(B) When Installing

9Y1210318ENS0107US0

(4) Piston and Connecting Rod

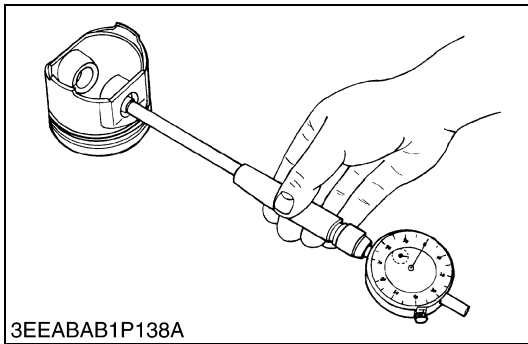

3EEABAB1P138A

Piston Pin Bore I.D.

1. Measure the piston pin bore I.D. in both the horizontal and vertical directions with a cylinder gauge.
2. If the measurement exceeds the allowable limit, replace the piston.

[WG752-G/GL-E3]

Piston pin bore I.D.	Factory specification	18.000 to 18.011 mm 0.70867 to 0.70909 in.
	Allowable limit	18.05 mm 0.7106 in.

[WG972-G/GL-E3]

Piston pin bore I.D.	Factory specification	20.000 to 20.013 mm 0.78741 to 0.78791 in.
	Allowable limit	20.05 mm 0.7894 in.

9Y1210571ENS0043US0

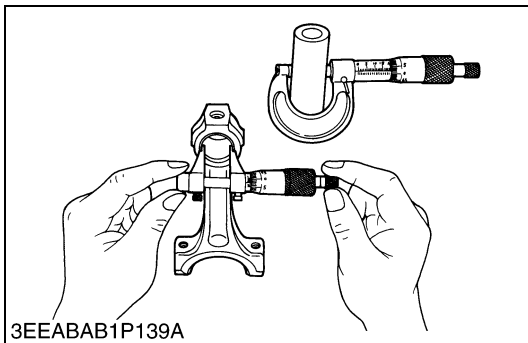

3EEABAB1P139A

Oil Clearance between Piston Pin and Small End Bushing

1. Measure the O.D. of the piston pin where it contacts the bushing with an outside micrometer.
2. Measure the small end bushing I.D. with an inside micrometer, and calculate the oil clearance.
3. If the oil clearance exceeds the allowable limit, replace the bushing. If it still exceeds the allowable limit, replace the piston pin.

[WG752-G/GL-E3]

Oil clearance between piston pin and small end bushing	Factory specification	0.02 to 0.04 mm 0.0008 to 0.001 in.
	Allowable limit	0.10 mm 0.0039 in.

Piston pin O.D.	Factory specification	18.000 to 18.005 mm 0.70867 to 0.70885 in.
Small end bushing I.D.	Factory specification	18.025 to 18.040 mm 0.70965 to 0.71023 in.

[WG972-G/GL-E3]

Oil clearance between piston pin and small end bushing	Factory specification	0.012 to 0.038 mm 0.00048 to 0.0014 in.
	Allowable limit	0.10 mm 0.0039 in.

Piston pin O.D.	Factory specification	20.002 to 20.013 mm 0.78748 to 0.78791 in.
Small end bushing I.D.	Factory specification	20.025 to 20.040 mm 0.78839 to 0.78897 in.

9Y1210571ENS0044US0

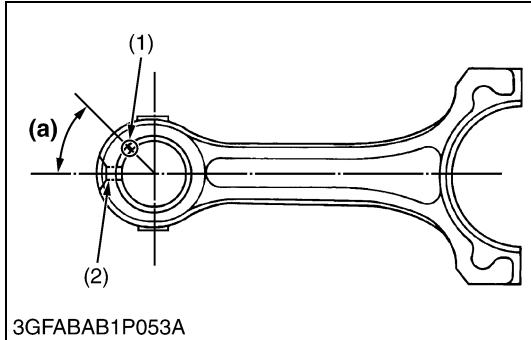
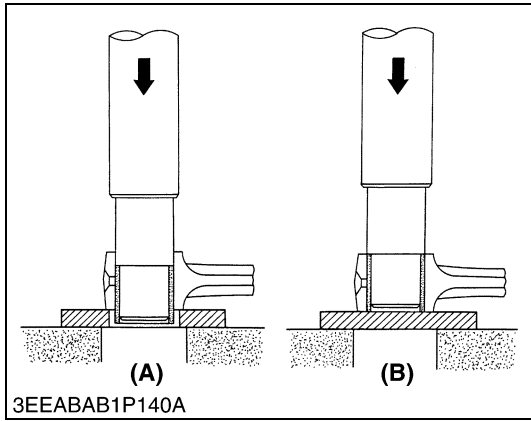

Replacing Small End Bushing

(When removing)

1. Press out the used bushing using a small end bushing replacing tool. (Refer to "5. SPECIAL TOOLS" on page G-27.)

(When installing)

1. Clean a new small end bushing and bore, and apply engine oil to them.
2. Using a small end bushing replacing tool, press in a new bushing (service parts) taking due care to see that the connecting rod hole matches the bushing hole.

[Servicing parts dimension]

[WG752-G/GL-E3]

Oil clearance between piston pin and small end bushing (Spare parts)	Factory specification	0.02 to 0.04 mm 0.0008 to 0.001 in.
	Allowable limit	0.10 mm 0.0039 in.

Small end bushing I.D. (Spare parts)	Factory specification	18.025 to 18.040 mm 0.70965 to 0.71023 in.
--------------------------------------	-----------------------	---

[WG972-G/GL-E3]

Oil clearance between piston pin and small end bushing (Spare parts)	Factory specification	0.013 to 0.075 mm 0.00052 to 0.0029 in.
	Allowable limit	0.15 mm 0.0059 in.

Small end bushing I.D. (Spare parts)	Factory specification	20.026 to 20.077 mm 0.78843 to 0.79043 in.
--------------------------------------	-----------------------	---

- (1) Seam
- (2) Oil Hole

- (A) When Removing**
- (B) When Installing**
- (a) 0.79 rad (45 °)**

9Y1210571ENS0045US0

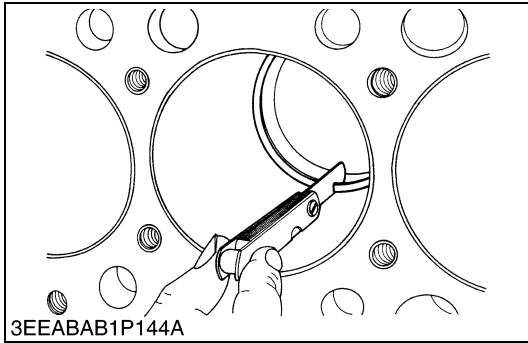

Piston Ring Gap

1. Insert the piston ring into the lower part of the cylinder (the least worn out part) with a piston ring compressor and piston.
2. Measure the ring gap with a feeler gauge.
3. If the measurement exceeds the allowable limit, replace the piston ring.

[WG752-G/GL-E3]

Piston ring gap	Top ring	Factory specification	0.15 to 0.35 mm 0.0059 to 0.013 in.
		Allowable limit	0.15 mm 0.0059 in.
	Second ring	Factory specification	0.15 to 0.35 mm 0.0059 to 0.013 in.
		Oil ring	Factory specification

[WG972-G/GL-E3]

Piston ring gap	Top ring	Factory specification	0.15 to 0.35 mm 0.0059 to 0.013 in.
		Allowable limit	1.25 mm 0.0492 in.
	Second ring	Factory specification	0.30 to 0.45 mm 0.012 to 0.017 in.
		Allowable limit	1.25 mm 0.0492 in.
	Oil ring	Factory specification	0.20 to 0.70 mm 0.0079 to 0.027 in.
		Allowable limit	1.25 mm 0.0492 in.

9Y1210571ENS0046US0

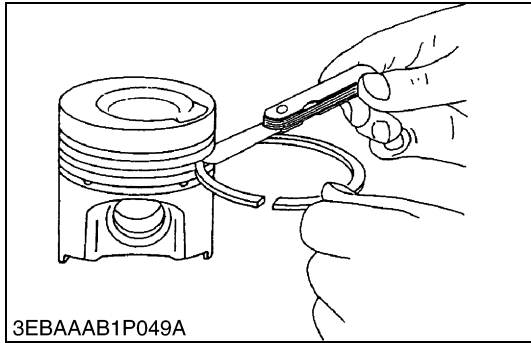

Clearance between Piston Ring and Piston Ring Groove

1. Clean the rings and the ring grooves, and install each ring in its groove.
2. Measure the clearance between the ring and the groove with a thickness gauge.
3. If the clearance exceeds the allowable limit, replace the piston ring.
4. If the clearance still exceeds the allowable limit with new ring, replace the piston.

[WG752-G/GL-E3]

Clearance between piston ring and piston ring groove	Top ring	Factory specification	0.04 to 0.08 mm 0.002 to 0.003 in.
		Allowable limit	0.15 mm 0.0059 in.
	Second ring	Factory specification	0.04 to 0.08 mm 0.002 to 0.003 in.
		Oil ring	Factory specification

[WG972-G/GL-E3]

Clearance between piston ring and piston ring groove	Top ring	Factory specification	0.080 to 0.12 mm 0.0032 to 0.0047 in.
		Allowable limit	0.15 mm 0.0059 in.
	Second ring	Factory specification	0.065 to 0.10 mm 0.0026 to 0.0039 in.
		Allowable limit	0.15 mm 0.0059 in.
	Oil ring	Factory specification	0.060 to 0.15 mm 0.0024 to 0.0059 in.
		Allowable limit	0.20 mm 0.0079 in.

9Y1210571ENS0047US0

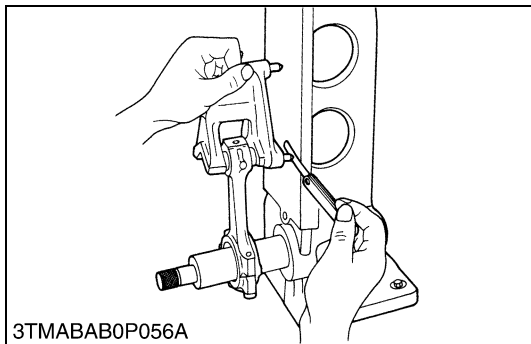

Connecting Rod Alignment

1. Remove the crankpin bearing, and install the connecting rod cap.
2. Install the piston pin in the connecting rod.
3. Install the connecting rod on the connecting rod alignment tool.
4. Put a gauge over the piston pin, and move it against the face plate.
5. If the gauge does not fit squarely against the face plate, measure the space between the pin of the gauge and the face plate.
6. If the measurement exceeds the allowable limit, replace the connecting rod.

Space between gauge pin face plate	Allowable limit	0.05 mm 0.002 in.
------------------------------------	-----------------	----------------------

9Y1210318ENS0113US0

(5) Crankshaft

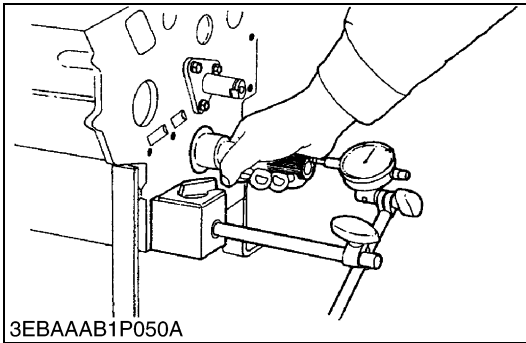

3EBAAAB1P050A

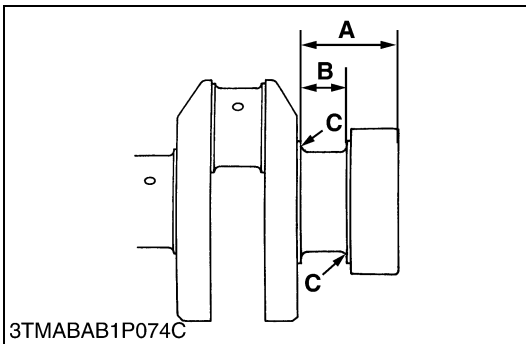

3TMABAB1P074C

Crankshaft Side Clearance

1. Set a dial indicator with its tip on the end of the crankshaft.
2. Measure the side clearance by moving the crankshaft to the front and rear.
3. If the measurement exceeds the allowable limit, replace the thrust bearings.
4. If the same size bearing is useless because of the crankshaft journal wear, replace it with an oversize one referring to the table and figure.

Crankshaft side clearance	Factory specification	0.15 to 0.31 mm 0.0059 to 0.012 in.
	Allowable limit	0.50 mm 0.020 in.

(Reference)

- Oversize thrust bearing

Oversize	Bearing	Code Number	Marking
0.2 mm 0.008 in.	Thrust bearing 1 02	15261-23950	020 OS
	Thrust bearing 2 02	15261-23970	020 OS
0.4 mm 0.02 in.	Thrust bearing 1 04	15261-23960	040 OS
	Thrust bearing 2 04	15261-23980	040 OS

- Oversize dimensions of crankshaft journal

Oversize	0.2 mm 0.008 in.	0.4 mm 0.02 in.
Dimension A	46.00 to 46.20 mm 1.811 to 1.818 in.	46.10 to 46.30 mm 1.815 to 1.822 in.
Dimension B	23.20 to 23.25 mm 0.9134 to 0.9153 in.	23.40 to 23.45 mm 0.9213 to 0.9232 in.
Dimension C	1.8 to 2.2 mm radius 0.071 to 0.086 in. radius	1.8 to 2.2 mm radius 0.071 to 0.086 in. radius

The crankshaft journal must be fine-finished to higher than Rmax = 0.8S

9Y1210571ENS0048US0

Crankshaft Alignment

1. Support the crankshaft with V blocks on the surface plate at both end journals.
2. Set a dial indicator with its tip on the intermediate journal.
3. Measure the crankshaft alignment.
4. If the measurement exceeds the allowable limit, replace the crankshaft.

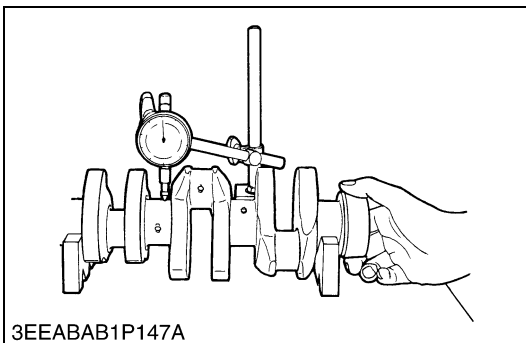

3EEABAB1P147A

Crankshaft alignment	Allowable limit	0.02 mm 0.0008 in.
----------------------	-----------------	-----------------------

9Y1210318ENS0115US0

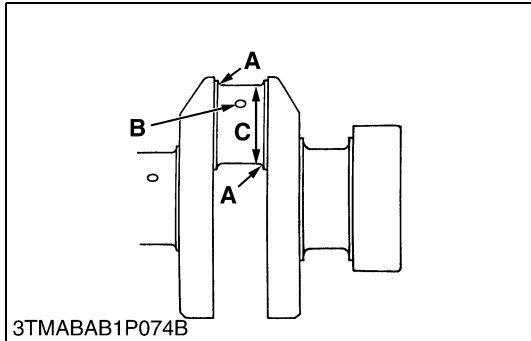
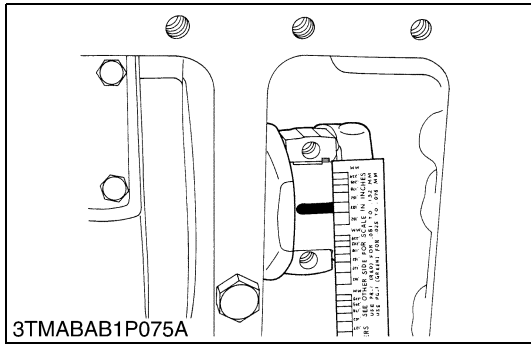

Oil Clearance between Crankpin and Crankpin Bearing

1. Clean the crankpin and crankpin bearing.
2. Put a strip of plastigage on the center of the crankpin.
3. Install the connecting rod cap and tighten the connecting rod screws to the specified torque, and remove the cap again.
4. Measure the amount of the flattening with the scale, and get the oil clearance.
5. If the oil clearance exceeds the allowable limit, replace the crankpin bearing.
6. If the same size bearing is useless because of the crankpin wear, replace it with an undersize one referring to the table and figure.

NOTE

- Never insert the plastigage into the crankpin oil hole.
- Be sure not to move the crankshaft while the connecting rod screws are tightened.

Oil clearance between crankpin and crankpin bearing	Factory specification	0.020 to 0.051 mm 0.00079 to 0.0020 in.
	Allowable limit	0.15 mm 0.0059 in.

Crankpin O.D.	Factory specification	33.959 to 33.975 mm 1.3370 to 1.3375 in.
Crankpin bearing I.D.	Factory specification	33.995 to 34.010 mm 1.3384 to 1.3389 in.

(Reference)

- Undersize crankpin bearing

Undersize	Bearing	Code Number	Marking
0.2 mm 0.008 in.	Crankpin bearing 02	15861-22970	020 US
0.4 mm 0.02 in.	Crankpin bearing 04	15861-20980	040 US

- Undersize dimensions of crankpin

Undersize	0.2 mm 0.008 in.	0.4 mm 0.02 in.
Dimension A	2.3 to 2.7 mm radius 0.091 to 0.10 in. radius	2.3 to 2.7 mm radius 0.091 to 0.10 in. radius
*Dimension B	1.0 to 1.5 mm relief 0.040 to 0.059 in. relief	1.0 to 1.5 mm relief 0.040 to 0.059 in. relief
Dimension C	33.759 to 33.775 mm dia. 1.3291 to 1.3297 in. dia.	33.559 to 33.575 mm dia. 1.3213 to 1.3218 in. dia.

The crankpin journal must be fine-finished to higher than Rmax = 0.8S

*Holes to be de-burred and edges rounded with 1.0 to 1.5 mm (0.040 to 0.059 in.) relief.

9Y1210318ENS0116US0

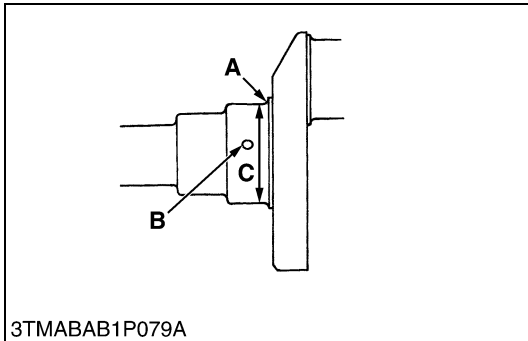
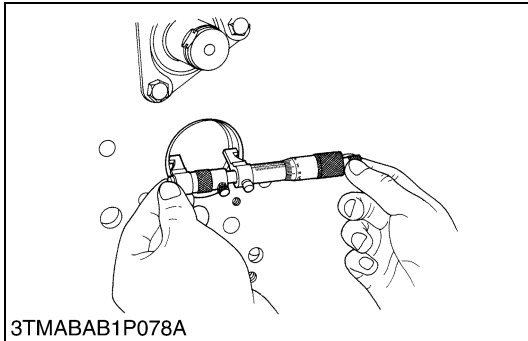
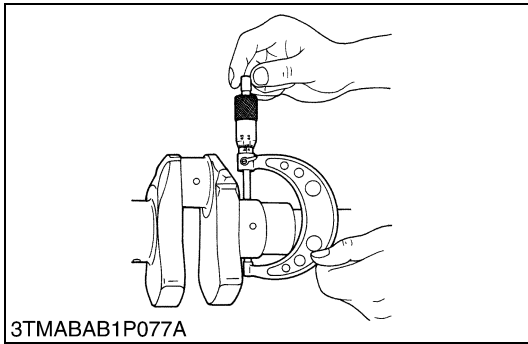

Oil Clearance between Crankshaft Journal and Crankshaft Bearing 1

1. Measure the O.D. of the crankshaft front journal with an outside micrometer.
2. Measure the I.D. of the crankshaft bearing 1 with an inside micrometer, and calculate the oil clearance.
3. If the oil clearance exceeds the allowable limit, replace the crankshaft bearing 1.
4. If the same size bearing is useless because of the crankshaft journal wear, replace it with an undersize one referring to the table and the figure.

Oil Clearance between crankshaft journal and crankshaft bearing 1	Factory specification	0.0340 to 0.106 mm 0.00134 to 0.00417 in.
	Allowable limit	0.20 mm 0.0079 in.

[WG752-G/GL-E3]

Crankshaft journal O.D.	Factory specification	39.934 to 39.950 mm 1.5722 to 1.5728 in.
Crankshaft bearing 1 I.D.	Factory specification	39.984 to 40.040 mm 1.5742 to 1.5763 in.

[WG972-G/GL-E3]

Crankshaft journal O.D.	Factory specification	43.934 to 43.950 mm 1.7297 to 1.7303 in.
Crankshaft bearing 1 I.D.	Factory specification	43.984 to 44.040 mm 1.7317 to 1.7338 in.

(Reference)

- Undersize crankshaft bearing 1

Undersize	Bearing	Code Number	Marking
0.2 mm 0.008 in.	Crankshaft bearing 1 02	1G460-23910	020 US
0.4 mm 0.02 in.	Crankshaft bearing 1 04	1G460-23920	040 US

- Undersize dimensions of crankshaft journal

Undersize	0.2 mm 0.008 in.	0.4 mm 0.02 in.
Dimension A	1.8 to 2.2 mm radius 0.071 to 0.086 in. radius	1.8 to 2.2 mm radius 0.071 to 0.086 in. radius
*Dimension B	1.0 to 1.5 mm relief 0.040 to 0.059 in. relief	1.0 to 1.5 mm relief 0.040 to 0.059 in. relief
Dimension C [WG752-G/GL-E3]	39.734 to 39.750 mm dia. 1.5644 to 1.5649 in. dia.	39.534 to 39.550 mm dia. 1.5565 to 1.5570 in. dia.
Dimension C [WG972-G/GL-E3]	43.734 to 43.750 mm dia. 1.7219 to 1.7224 in. dia.	43.534 to 43.550 mm dia. 1.7140 to 1.7145 in. dia.

The crankshaft journal must be fine-finished to higher than Rmax = 0.8S
 *Holes to be de-burred and edges rounded with 1.0 to 1.5 mm (0.040 to 0.059 in.) relief.

9Y1210571ENS0049US0

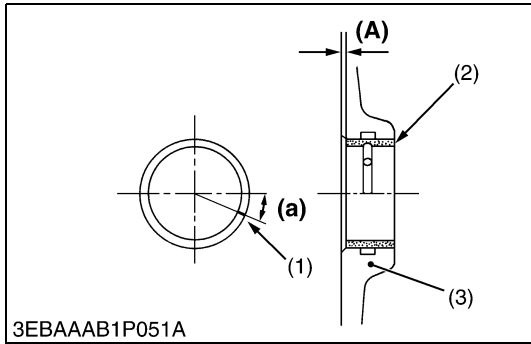

Replacing Crankshaft Bearing 1

(When removing)

1. Press out the used crankshaft bearing 1 using a crankshaft bearing 1 replacing tool.

(When installing)

1. Clean a new crankshaft bearing 1 and crankshaft journal bore, and apply engine oil to them.
2. Using a crankshaft bearing 1 replacing tool, press in a new bearing 1 (2) so that its seam (1) directs toward the exhaust manifold side. (See figure.)

Dimension (A)	Factory specification	0 to 0.3 mm 0 to 0.01 in.
---------------	-----------------------	------------------------------

- (1) Seam
- (2) Crankshaft Bearing 1
- (3) Cylinder Block

(A) Dimension
(a) 0.37 rad (21 °)

9Y1210318ENS0118US0

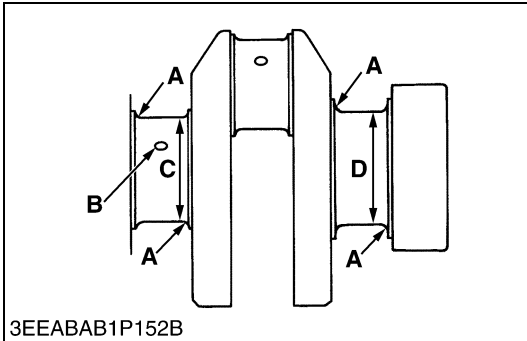
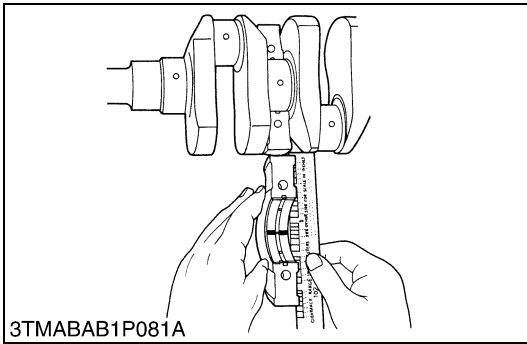

Oil Clearance between Crankshaft Journal and Crankshaft Bearing 2 (Crankshaft Bearing 3)

1. Put a strip of plastigage on the center of the journal.
2. Install the bearing case and tighten the bearing case screws 1 to the specified torque, and remove the bearing case again.
3. Measure the amount of the flattening with the scale, and get the oil clearance.
4. If the oil clearance exceeds the allowable limit, replace the crankshaft bearing 2 (crankshaft bearing 3).
5. If the same size bearing is useless because of the crankshaft journal wear, replace it with an undersize one referring to the table and figure.

■ **NOTE**

- **Be sure not to move the crankshaft while the bearing case screws are tightened.**

Oil clearance between crankshaft journal and crankshaft bearing 2	Factory specification	0.028 to 0.059 mm 0.0011 to 0.0023 in.
	Allowable limit	0.20 mm 0.0079 in.

Crankshaft journal O.D. (Flywheel side)	Factory specification	43.934 to 43.950 mm 1.7297 to 1.7303 in.
---	-----------------------	---

Crankshaft bearing 2 I.D.	Factory specification	43.978 to 43.993 mm 1.7315 to 1.7320 in.
---------------------------	-----------------------	---

[WG752-G/GL-E3]

Oil clearance between crankshaft journal and crankshaft bearing 3	Factory specification	0.028 to 0.059 mm 0.0011 to 0.0023 in.
	Allowable limit	0.20 mm 0.0079 in.

Crankshaft journal O.D. (Intermediate)	Factory specification	39.934 to 39.950 mm 1.5722 to 1.5728 in.
--	-----------------------	---

Crankshaft bearing 3 I.D.	Factory specification	39.978 to 39.993 mm 1.5740 to 1.5745 in.
---------------------------	-----------------------	---

[WG972-G/GL-E3]

Oil clearance between crankshaft journal and crankshaft bearing 3	Factory specification	0.028 to 0.059 mm 0.0011 to 0.0023 in.
	Allowable limit	0.20 mm 0.0079 in.

Crankshaft journal O.D. (Intermediate)	Factory specification	43.934 to 43.950 mm 1.7297 to 1.7303 in.
--	-----------------------	---

Crankshaft bearing 3 I.D.	Factory specification	43.978 to 43.993 mm 1.7315 to 1.7320 in.
---------------------------	-----------------------	---

(To be continued)

(Continued)

(Reference)

- Undersize crankshaft bearing 2 and 3

[WG752-G/GL-E3]

Undersize	Bearing	Code Number	Marking
0.2 mm 0.008 in.	Crankshaft bearing 2 02	15694-23931	020 US
	Crankshaft bearing 3 02	15861-23861	020 US
0.4 mm 0.016 in.	Crankshaft bearing 2 04	15694-23941	040 US
	Crankshaft bearing 3 04	15861-23871	040 US

[WG972-G/GL-E3]

Undersize	Bearing	Code Number	Marking
0.2 mm 0.008 in.	Crankshaft bearing 2 02	15694-23930	020 US
	Crankshaft bearing 2F 02	1G460-07530	
	Crankshaft bearing 3 02	1G460-07580	020 US
	Crankshaft bearing 3F 02	1G460-07630	
0.4 mm 0.02 in.	Crankshaft bearing 2 04	15694-23940	040 US
	Crankshaft bearing 2F 04	1G460-07540	
	Crankshaft bearing 3 04	1G460-07590	040 US
	Crankshaft bearing 3F 04	1G460-07640	

- Undersize dimensions of crankshaft journal

[WG752-G/GL-E3]

Undersize	0.2 mm 0.008 in.	0.4 mm 0.02 in.
Dimension A	1.8 to 2.2 mm radius 0.071 to 0.087 in. radius	1.8 to 2.2 mm radius 0.071 to 0.087 in. radius
*Dimension B	1.0 to 1.5 mm relief 0.040 to 0.059 in. relief	1.0 to 1.5 mm relief 0.040 to 0.059 in. relief
Dimension C	39.734 to 39.750 mm 1.56433 to 1.56496 in.	39.534 to 39.550 mm 1.55646 to 1.55709 in.
Dimension D	43.734 to 43.750 mm 1.72181 to 1.72244 in.	43.534 to 43.550 mm 1.71394 to 1.71457 in.
The crankshaft journal must be fine-finished to higher than Rmax = 0.8S *Holes to be de-burred and edges rounded with 1.0 to 1.5 mm (0.040 to 0.059 in.) relief.		

[WG972-G/GL-E3]

Undersize	0.2 mm 0.008 in.	0.4 mm 0.02 in.
Dimension A	1.8 to 2.2 mm radius 0.071 to 0.086 in. radius	1.8 to 2.2 mm radius 0.071 to 0.086 in. radius
*Dimension B	1.0 to 1.5 mm relief 0.040 to 0.059 in. relief	1.0 to 1.5 mm relief 0.040 to 0.059 in. relief
Dimension C, D	43.734 to 43.750 mm dia. 1.7219 to 1.7224 in. dia.	43.534 to 43.550 mm dia. 1.7140 to 1.7145 in. dia.
The crankshaft journal must be fine-finished to higher than Rmax = 0.8S *Holes to be de-burred and edges rounded with 1.0 to 1.5 mm (0.040 to 0.059 in.) relief.		

9Y1210571ENS0053US0

(6) Cylinder

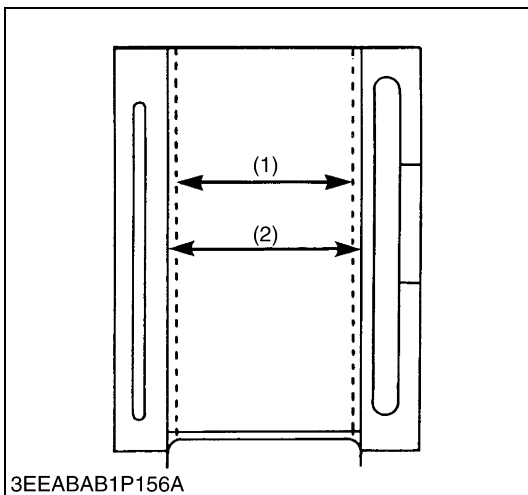
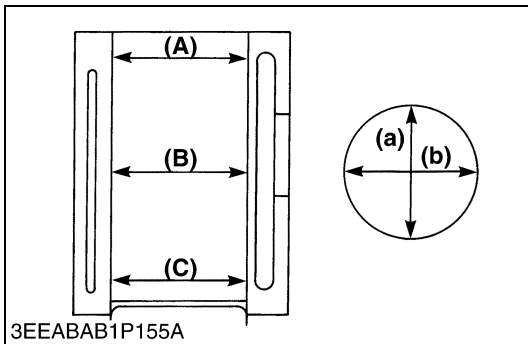
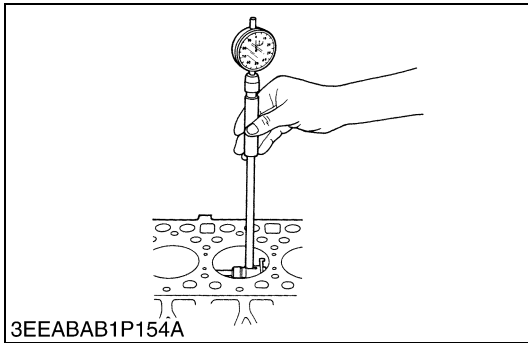

Cylinder Wear

1. Measure the I.D. of the cylinder at the six positions (see figure) with a cylinder gauge to find the maximum and minimum I.D.'s.
2. Get the difference (Maximum wear) between the maximum and the minimum I.D.'s.

[WG752-G/GL-E3]

Cylinder liner I.D.	Factory specification	68.000 to 68.019 mm 2.6772 to 2.6779 in.
	Allowable limit	68.169 mm 2.6838 in.

[WG972-G/GL-E3]

Cylinder I.D.	Factory specification	74.500 to 74.519 mm 2.9331 to 2.9338 in.
	Allowable limit	74.669 mm 2.9397 in.

- (A) Top
(B) Middle
(C) Bottom (Skirt)

- (a) Right-Angled to Piston Pin
(b) Piston Pin Direction

9Y1210571ENS0051US0

Correcting Cylinder (Oversize)

1. When the cylinder is worn beyond the allowable limit, bore and hone it to the specified dimension.

[WG752-G/GL-E3]

Cylinder cylinder liner I.D.	Factory specification	68.500 to 68.519 mm 2.6969 to 2.6975 in.
	Allowable limit	68.669 mm 2.7035 in.
Finishing	Hone to 1.2 to 2.0 μmRz (48 to 78 $\mu\text{in.Rz}$)	

[WG972-G/GL-E3]

Cylinder liner I.D.	Factory specification	75.000 to 75.019 mm 2.9528 to 2.9535 in.
	Allowable limit	75.150 mm 2.9587 in.
Finishing	Hone to 2.2 to 3.0 μmRz (87 to 110 $\mu\text{in.Rz}$)	

2. Replace the piston and piston rings with oversize ones.
Oversize : 0.5 mm (0.02 in.)
Marking : 05

■ NOTE

- When the oversize cylinder is worn beyond the allowable limit, replace the cylinder block with a new one.

- (1) Cylinder I.D. (Before Correction) (2) Cylinder I.D. (Oversize)

9Y1210571ENS0052US0

(7) Oil Pump

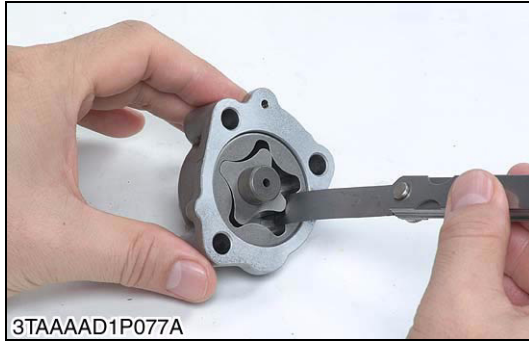

Rotor Lobe Clearance

1. Measure the clearance between lobes of the inner rotor and the outer rotor with a thickness gauge.
2. If the clearance exceeds the factory specifications, replace the oil pump rotor assembly.

Rotor lobe clearance	Factory specification	0.030 to 0.14 mm 0.0012 to 0.0055 in.
----------------------	-----------------------	--

9Y1210318ENS0122US0

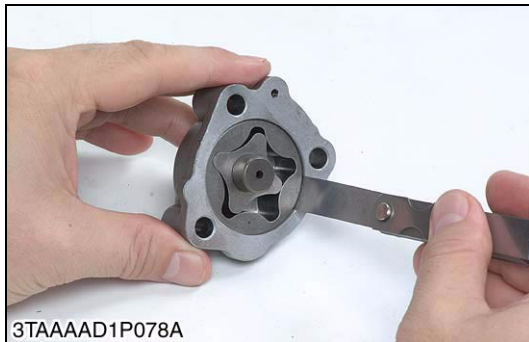

Clearance between Outer Rotor and Pump Body

1. Measure the clearance between the outer rotor and the pump body with a thickness gauge.
2. If the clearance exceeds the factory specifications, replace the oil pump rotor assembly.

Clearance between outer rotor and pump body	Factory specification	0.070 to 0.15 mm 0.0028 to 0.0059 in.
---	-----------------------	--

9Y1210318ENS0123US0

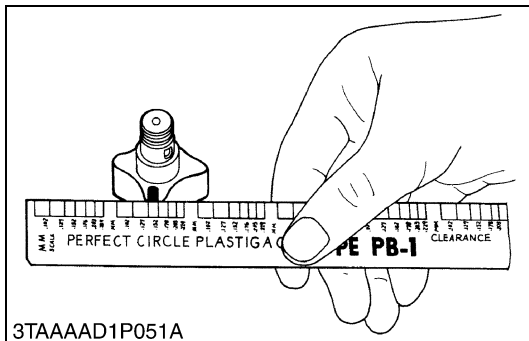

Clearance between Rotor and Cover

1. Put a strip of plastigage onto the rotor face with grease.
2. Install the cover and tighten the screws.
3. Remove the cover carefully, and measure the amount of the flattening with the scale and get the clearance.
4. If the clearance exceeds the factory specifications, replace oil pump rotor assembly.

Clearance between rotor and cover	Factory specification	0.0750 to 0.135 mm 0.00296 to 0.00531 in.
-----------------------------------	-----------------------	--

9Y1210318ENS0124US0

(8) Starter

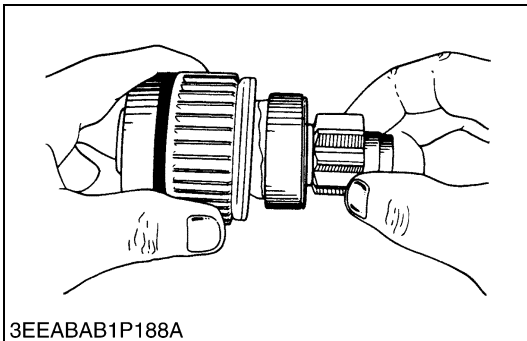

3EEABAB1P188A

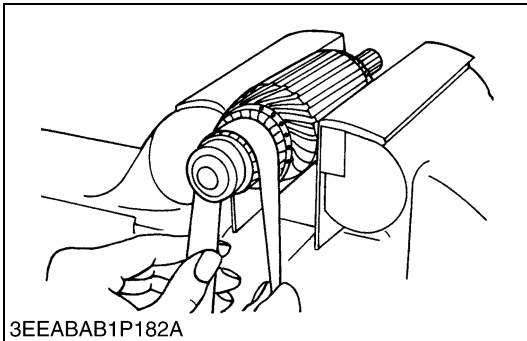

3EEABAB1P182A

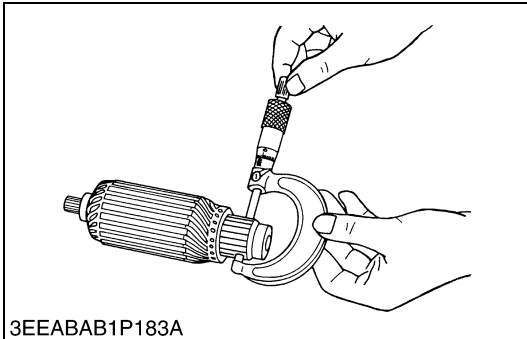

3EEABAB1P183A

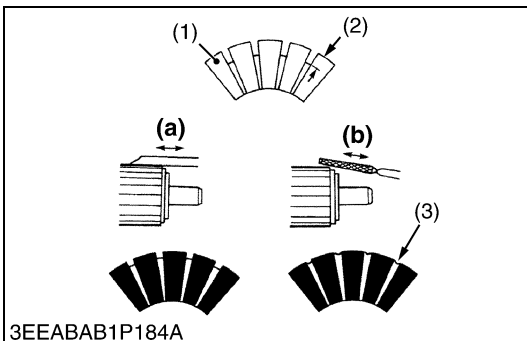

3EEABAB1P184A

Overrunning Clutch

1. Inspect the pinion for wear or damage.
2. If there is any defect, replace the overrunning clutch assembly.
3. Check that the pinion turns freely and smoothly in the overrunning direction and does not slip in the cranking direction.
4. If the pinion slips or does not rotate in the both directions, replace the overrunning clutch assembly.

9Y1210318ENS0125US0

Commutator and Mica

1. Check the contact face of the commutator for wear, and grind the commutator with emery paper if it is slightly worn.
2. Measure the commutator O.D. with an outside micrometer at several points.
3. If the minimum O.D. is less than the allowable limit, replace the armature.
4. If the difference of the O.D.'s exceeds the allowable limit, correct the commutator on a lathe to the factory specification.
5. Measure the mica undercut.
6. If the undercut is less than the allowable limit, correct if with a saw blade and chamfer the segment edges.

[WG752-G/GL-E3]

Commutator O.D.	Factory specification	32.0 mm 1.26 in.
	Allowable limit	31.0 mm 1.22 in.

Difference of O.D.'s	Factory specification	Less than 0.05 mm 0.002 in.
	Allowable limit	0.4 mm 0.02 in.

Mica under cut	Factory specification	0.5 to 0.8 mm 0.02 to 0.03 in.
	Allowable limit	0.4 mm 0.02 in.

[WG972-G/GL-E3]

Commutator O.D.	Factory specification	28.0 mm 1.10 in.
	Allowable limit	27.0 mm 1.06 in.

Difference of O.D.'s	Factory specification	Less than 0.05 mm 0.002 in.
	Allowable limit	0.4 mm 0.02 in.

Mica under cut	Factory specification	0.45 to 0.75 mm 0.018 to 0.029 in.
	Allowable limit	0.2 mm 0.008 in.

- | | |
|--------------|----------|
| (1) Segment | (a) Good |
| (2) Undercut | (b) Bad |
| (3) Mica | |

9Y1210318ENS0126US0

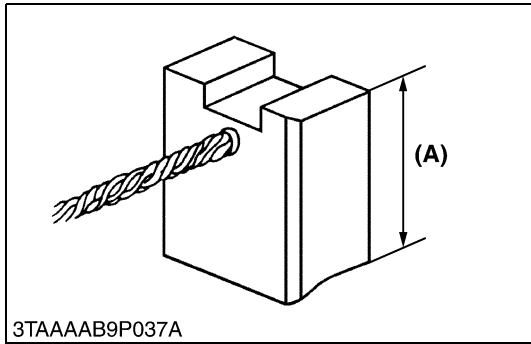

Brush Wear

1. If the contact face of the brush is dirty or dusty, clean it with emery paper.
2. Measure the brush length **(A)** with vernier calipers.
3. If the length is less than the allowable limit, replace the yoke assembly and brush holder.

Brush length (A)	Factory specification	14.0 mm 0.551 in.
	Allowable limit	11.1 mm 0.437 in.

(A) Brush Length

9Y1210318ENS0127US0

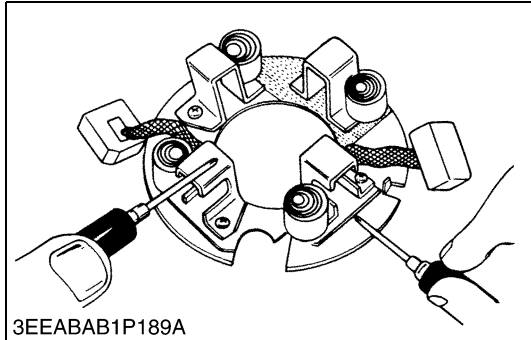

Brush Holder

1. Check the continuity across the brush holder and the holder support with an ohmmeter.
2. If it conducts, replace the brush holder.

9Y1210318ENS0128US0

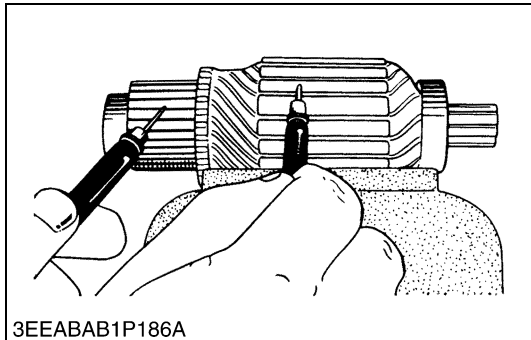

Armature Coil

1. Check the continuity across the commutator and armature coil core with an ohmmeter.
2. If it conducts, replace the armature.
3. Check the continuity across the segments of the commutator with an ohmmeter.
4. If it does not conduct, replace the armature.

9Y1210318ENS0129US0

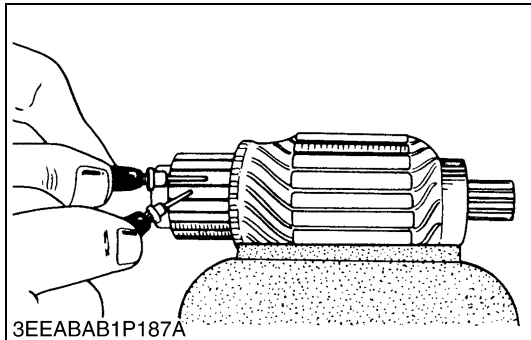

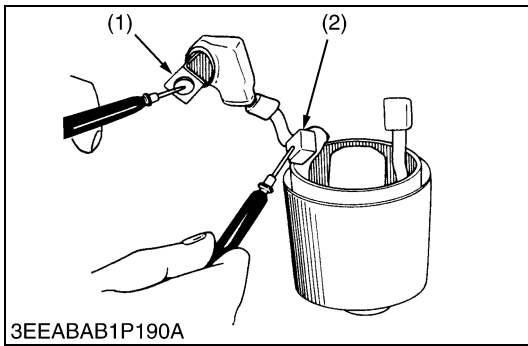

3EEABAB1P190A

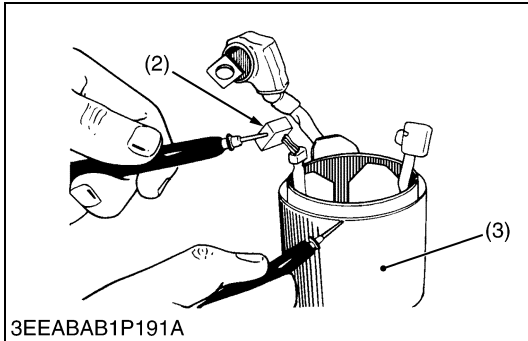

3EEABAB1P191A

Field Coil

1. Check the continuity across the lead (1) and brush (2) with an ohmmeter.
2. If it does not conduct, replace the yoke assembly.
3. Check the continuity across the brush (2) and yoke (3) with an ohmmeter.
4. If it conducts, replace the yoke assembly.

- (1) Lead
- (2) Brush
- (3) Yoke

9Y1210318ENS0130US0

(9) Alternator

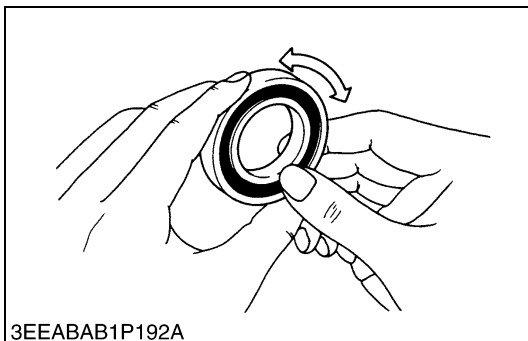

3EEABAB1P192A

Bearing

1. Check the bearing for smooth rotation.
2. If it does not rotate smoothly, replace it.

9Y1210318ENS0131US0

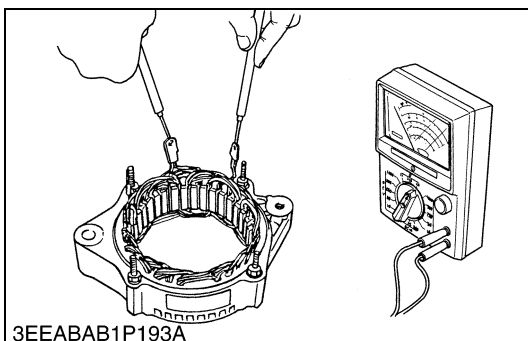

3EEABAB1P193A

Stator

1. Measure the resistance across each lead of the stator coil with resistance range of circuit tester.
2. If the measurement is not within factory specification, replace it.
3. Check the continuity across each stator coil lead and core with resistance range of circuit tester.
4. If infinity is not indicated, replace it.

Resistance	Factory specification	Less than 1.0 Ω
------------	-----------------------	-----------------

9Y1210318ENS0132US0

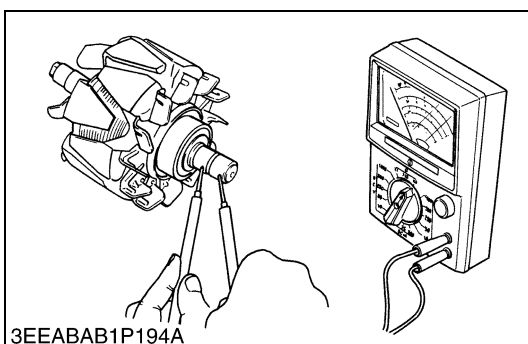

3EEABAB1P194A

Rotor

1. Measure the resistance across the slip rings.
2. If the resistance is not the factory specification, replace it.
3. Check the continuity across the slip ring and core with resistance range of circuit tester.
4. If infinity is not indicated, replace it.

Resistance	Factory specification	2.9 Ω
------------	-----------------------	-------

9Y1210318ENS0133US0

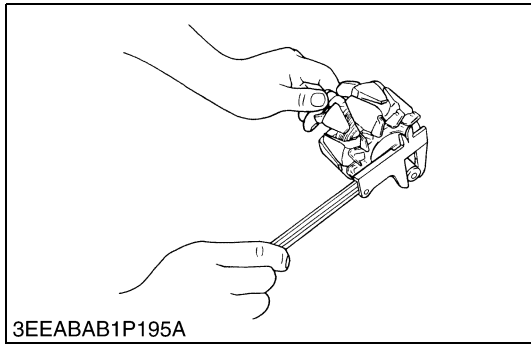

Slip Ring

1. Check the slip ring for score.
2. If scored, correct with an emery paper or on a lathe.
3. Measure the O.D. of slip ring with vernier calipers.
4. If the measurement is less than the allowable limit, replace it.

Slip ring O.D.	Factory specification	14.4 mm 0.567 in.
	Allowable limit	14.0 mm 0.551 in.

9Y1210318ENS0134US0

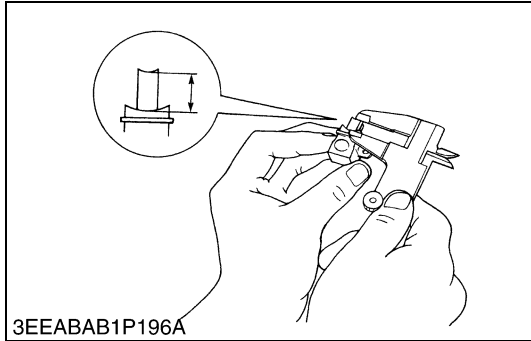

Brush Wear

1. Measure the brush length with vernier calipers.
2. If the measurement is less than allowable limit, replace it.
3. Make sure that the brush moves smoothly.
4. If the brush is defective, replace it.

Brush length	Factory specification	10.5 mm 0.413 in.
	Allowable limit	8.4 mm 0.33 in.

9Y1210318ENS0135US0

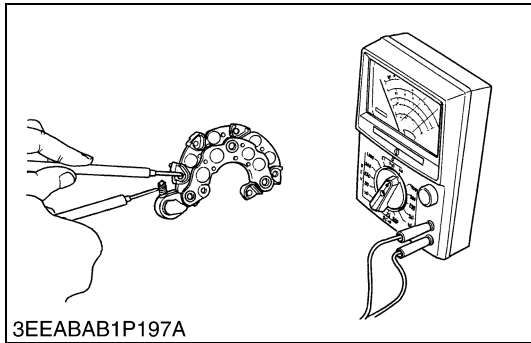

Rectifier

1. Check the continuity across each diode of rectifier with resistance range of circuit tester.
2. The rectifier is normal if the diode in the rectifier conducts in one direction and does not conduct in the reverse direction.

9Y1210318ENS0136US0

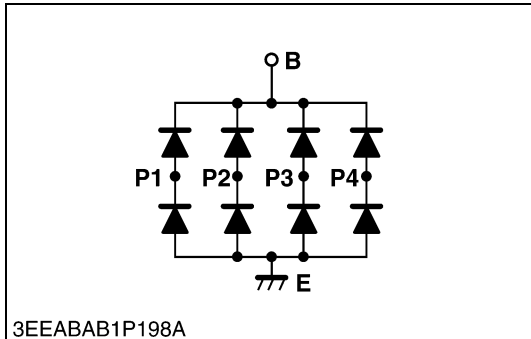

IC Regulator

1. Check the continuity across the **B** terminal (2) and the **F** terminal (1) of IC regulator with resistance range of circuit tester.
2. The IC regulator is normal if the conducts in one direction and does not conduct in the reverse direction.

(1) **F** Terminal

(2) **B** Terminal

9Y1210318ENS0137US0

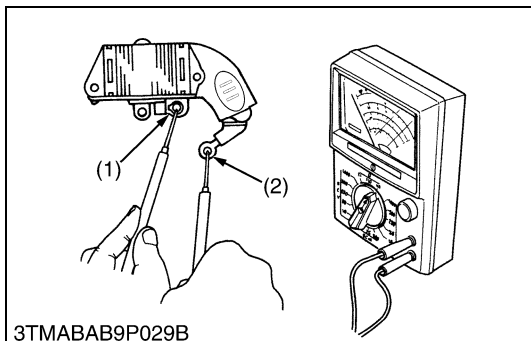

EDITOR:

KUBOTA FARM & INDUSTRIAL MACHINERY SERVICE, LTD.

64, ISHIZU-KITAMACHI, SAKAI-KU, SAKAI-CITY, OSAKA, 590-0823, JAPAN

PHONE : (81)72-241-1129

FAX : (81)72-245-2484

E-mail : ksos-pub@kubota.co.jp
