



## SPARE PARTS MANUAL

# MQ WHITEMAN DUOSCREENED DSGPULW (Special Order)



Version 1.0 (February 2024)

FOR MORE INFORMATION VISIT [flextool.com.au](http://flextool.com.au)

EXCLUSIVE TO



# PARTS MANUAL



## **MODEL DSGPULW DUOSCREEN LIGHTWEIGHT (HONDA GX35SAT GASOLINE ENGINE)**

Revision #8 (06/12/23)

To find the latest revision of this publication or associated operation manual, visit our website at: [www.multiquip.com](http://www.multiquip.com)



THIS MANUAL MUST ACCOMPANY THE EQUIPMENT AT ALL TIMES.

**DSGPULW VIBRATORY  
DUOSCREED**

Explanation Of Code In Remarks Column..... 4  
Suggested Spare Parts ..... 5  
Nameplate And Decals ..... 6-7  
Main Assembly ..... 8-11  
Engine Service Parts ..... 12-13

**NOTICE**  
Part numbers are subject to change without notice.



# EXPLANATION OF CODE IN REMARKS COLUMN

The following section explains the different symbols and remarks used in the Parts section of this manual. Use the help numbers found on the back page of the manual if there are any questions.

## NOTICE

The contents and part numbers listed in the parts section are subject to change **without notice**. Multiquip does not guarantee the availability of the parts listed.

## SAMPLE PARTS LIST

NO.	PART NO.	PART NAME	QTY.	REMARKS
1	12345	BOLT.....	1	INCLUDES ITEMS W/%
2%		WASHER, 1/4 IN.....		NOT SOLD SEPARATELY
2%	12347	WASHER, 3/8 IN.....	1	MQ-45T ONLY
3	12348	HOSE .....		A/R ...MAKE LOCALLY
4	12349	BEARING .....	1	S/N 2345B AND ABOVE

## NO. Column

**Unique Symbols** — All items with same unique symbol

(@, #, +, %, or >) in the number column belong to the same assembly or kit, which is indicated by a note in the “Remarks” column.

**Duplicate Item Numbers** — Duplicate numbers indicate multiple part numbers, which are in effect for the same general item, such as different size saw blade guards in use or a part that has been updated on newer versions of the same machine.

## NOTICE

When ordering a part that has more than one item number listed, check the remarks column for help in determining the proper part to order.

## PART NO. Column

**Numbers Used** — Part numbers can be indicated by a number, a blank entry, or TBD.

TBD (To Be Determined) is generally used to show a part that has not been assigned a formal part number at the time of publication.

A blank entry generally indicates that the item is not sold separately or is not sold by Multiquip. Other entries will be clarified in the “Remarks” Column.

## QTY. Column

**Numbers Used** — Item quantity can be indicated by a number, a blank entry, or A/R.

A/R (As Required) is generally used for hoses or other parts that are sold in bulk and cut to length.

A blank entry generally indicates that the item is not sold separately. Other entries will be clarified in the “Remarks” Column.

## REMARKS Column

Some of the most common notes found in the “Remarks” Column are listed below. Other additional notes needed to describe the item can also be shown.

**Assembly/Kit** — All items on the parts list with the same unique symbol will be included when this item is purchased.

Indicated by:

“INCLUDES ITEMS W/(unique symbol)”

**Serial Number Break** — Used to list an effective serial number range where a particular part is used.

Indicated by:

“S/N XXXXX AND BELOW”

“S/N XXXX AND ABOVE”

“S/N XXXX TO S/N XXX”

**Specific Model Number Use** — Indicates that the part is used only with the specific model number or model number variant listed. It can also be used to show a part is NOT used on a specific model or model number variant.

Indicated by:

“XXXXX ONLY”

“NOT USED ON XXXX”

**“Make/Obtain Locally”** — Indicates that the part can be purchased at any hardware shop or made out of available items. Examples include battery cables, shims, and certain washers and nuts.

**“Not Sold Separately”** — Indicates that an item cannot be purchased as a separate item and is either part of an assembly/kit that can be purchased, or is not available for sale through Multiquip.

## SUGGESTED SPARE PARTS

### DSGPULW DUOSCREED WITH HONDA GX35SAT GASOLINE ENGINE

1 to 3 units

Qty.	P/N	Description
2	BF2648	HANDLE GRIP
1	BF2647	THROTTLE GRIP
2	BF2645LW	THROTTLE CABLE
1	BF2621LW	FLEXIBLE SHAFT
1	BF2609N	ECCENTRIC COVER
3	BF2607	COMPRESSION SPRING
1	BF2605LW	ALUMINUM CLAMPING STRIP
3	BF0176	WASHER
3	BF2606	WING BOLT
1	BF2643	STOP SWITCH
3	BF0325	WING BOLT M6X12
3	31915Z0H003	SPARK PLUG, NGK
3	17211Z0Z000	ELEMENT AIR
1	15600ZM3003	CAP, OIL FILLER
1	28400Z0Z003	RECOIL STARTER ASSY.
3	17672ZM3003	FILTER, FUEL
1	17620ZM3043	CAP ASSY., FUEL TANK
1	28462ZM3003	ROPE, RECOIL STARTER

#### NOTICE

Part numbers on this Suggested Spare Parts list may supersede/replace the part numbers shown in the following parts lists.

# NAMEPLATE AND DECALS

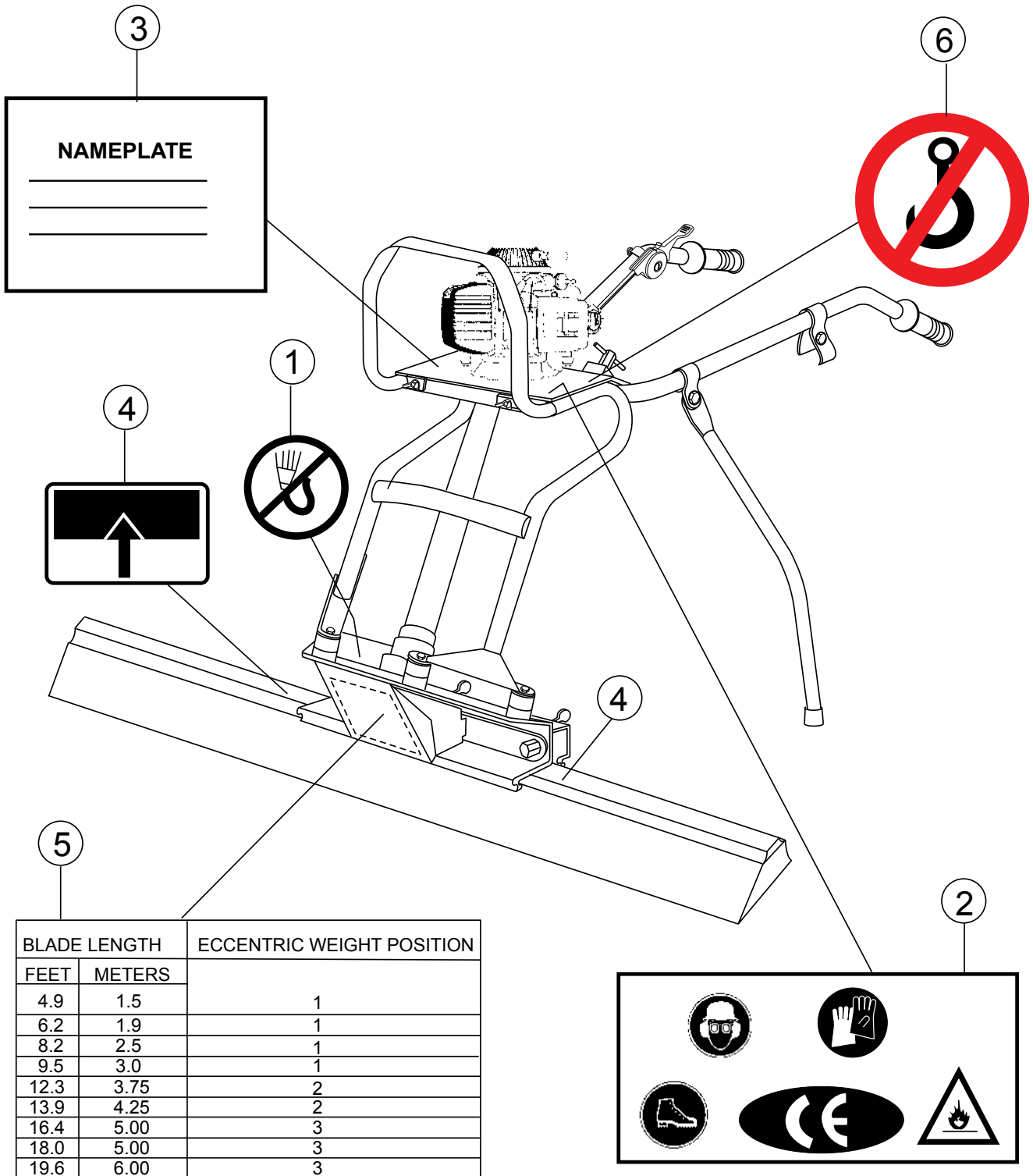

## NAMEPLATE AND DECALS

---

<u>NO.</u>	<u>PART NO.</u>	<u>PART NAME</u>	<u>QTY.</u>	<u>REMARKS</u>
1#	DCL121	DECAL, PRESSURE HOSE	1	
2#	DCL122	DECAL, SAFETY	1	
3		PLATE, SERIAL NO.....	1.....	CONTACT MQ PARTS DEPT. W/MODEL AND S/N
4#	DCL140	DECAL, ALIGNMENT ARROWS	2	
5#	DCL141	DECAL, ECCENTRIC WT. CHART	1	
6	BF260002	DECAL, DO NOT LIFT (HOOK)	1	
	DCLDS-SERIES	KIT, DECAL.....	1.....	INCLUDES ITEMS W/#



# MAIN ASSY.

OLD STYLE  
CENTRIFUGAL  
HOUSING

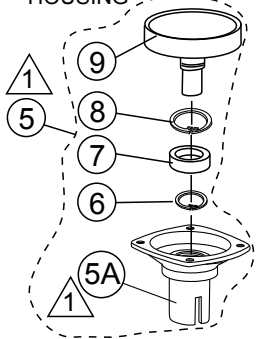

NEW STYLE  
CENTRIFUGAL  
HOUSING

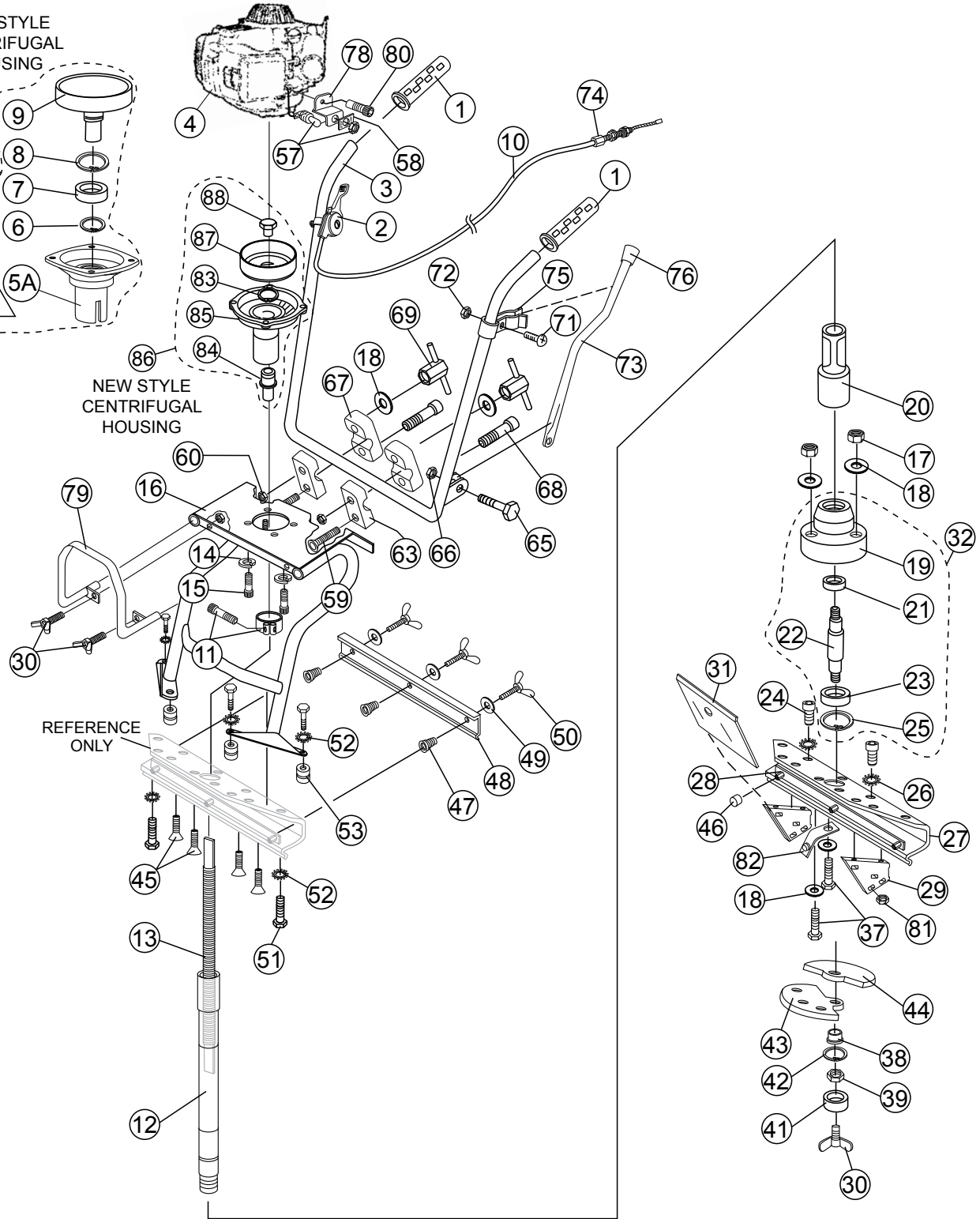

REFERENCE  
ONLY

NOTES

1 OLD STYLE CENTRIFUGAL HOUSING ASSEMBLY  
NO LONGER AVAILABLE. IF REPLACEMENT OF ITEM 5A  
IS REQUIRED, ORDER NEW STYLE HOUSING ASSEMBLY, ITEM 86.

# MAIN ASSY.

<u>NO.</u>	<u>PART NO.</u>	<u>PART NAME</u>	<u>QTY.</u>	<u>REMARKS</u>
1	BF2648	HANDLE GRIP	2	
2	BF2647	THROTTLE HANDLE	1	
3	BF2633LW	UPPER OPERATING HANDLE	1	
4	2640A35	ENGINE HONDA GX-35SAT	1	
5		CENTRIFUGAL CLUTCH HOUSING CP .....	1	NO LONGER AVAILABLE S/N 0185 AND BELOW SEE NOTE ON DRAWING INCLUDES ITEM W/\$
5A\$		CENTRIFUGAL CLUTCH HOUSING .....	1	NO LONGER AVAILABLE S/N 0185 AND BELOW SEE NOTE ON DRAWING
6\$	BF0201	RETAINING RING 17 X 1 MM .....	1	S/N 0185 AND BELOW IN CENTRIFUGAL HOUSING
7\$	BF2642C	BEARING IN CENTRIFUGAL HOUSING .....	1	S/N 0185 AND BELOW
8\$	BF0205	RETAINING RING (BIG) .....	1	S/N 0185 AND BELOW
9\$	BF2642	CENTRIFUGAL DRUM .....	1	S/N 0185 AND BELOW
10	BF2645LW	INNER & OUTER CABLE, 87 CMS.	1	
11	BF2626	CENTRIFUGAL HOUSING CLAMP	1	
12	BF2625LW	RUBBER HOSE WITH CONNECTORS	1	
13	BF2621LW	FLEXIBLE SHAFT	1	
14	BF0178	SPRING WASHER M6 TYPE B	4	
15	BF0165	SOCKET HEAD BOLT M6 X 25	4	
16	BF2632LW	LOWER OPERATING HANDLE	1	
17	BF0101	SELF LOCKING NUT M8	3	
18	BF0155	FLAT WASHER M8	8	
19%	BF2611	ECCENTRIC HOUSING	1	
20	BF1100000008	COUPLING DRIVE PIN	1	
21%	BF2619	BEARING (SMALL)	1	
22%	BF2612	ECCENTRIC SHAFT	1	
23%	BF2314	BEARING (BIG)	1	
24	BF0278	TAP BOLT M8 X 30 .....	4	REPLACES P/N BF0125
25%	BF0201	RETAINING RING 17 X 1MM	1	
26	BF0213	TOOTH WASHER M8	4	
27	BF2604LW	ECCENTRIC ASSEMBLY PLATE	1	
28	BF2610LW	STRIP & NUTS FOR ALUMINUM CLAMP	1	
29	BF2608N	SUPPORT BLOCK	2	
30	BF0325	WING BOLT M6 X12	3	
31	BF2609N	ECCENTRIC COVER	1	
32	BF2611KOMPL	ECCENTRIC HOUSING COMPLETE .....	1	INCLUDES ITEMS W/%
37	BF0129	TAP BOLT M8 X 40	3	
38	BF2614	ECCENTRIC HINGE BUSHING	1	
39	BF0177	NUT M12 (FINE)	1	
41	BF2613	ECCENTRIC CLAMPING BUSH	1	

# MAIN ASSY. (CONT'D.)

OLD STYLE  
CENTRIFUGAL  
HOUSING

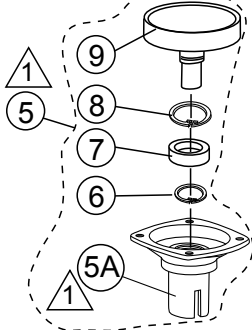

NEW STYLE  
CENTRIFUGAL  
HOUSING



REFERENCE  
ONLY

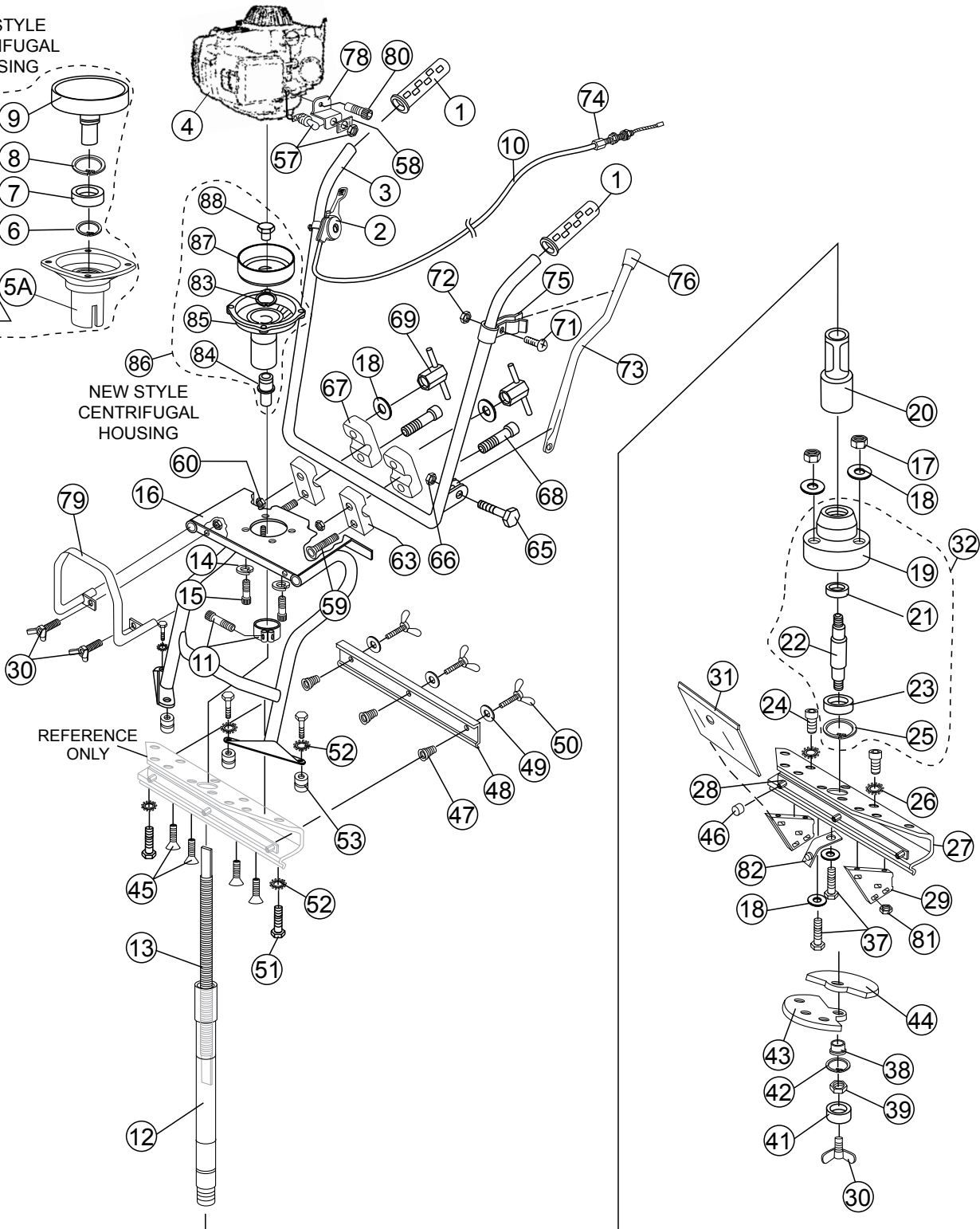

NOTES

1 OLD STYLE CENTRIFUGAL HOUSING ASSEMBLY NO LONGER AVAILABLE. IF REPLACEMENT OF ITEM 5A IS REQUIRED, ORDER NEW STYLE HOUSING ASSEMBLY, ITEM 86.

## MAIN ASSY. (CONT'D.)

<u>NO.</u>	<u>PART NO.</u>	<u>PART NAME</u>	<u>QTY.</u>	<u>REMARKS</u>
42	BF0175	RETAINING RING M12	1	
43	BF2615A	ECCENTRIC PLATE (SMALL)	1	
44	BF2615B	ECCENTRIC PLATE (BIG)	1	
45	BF0207	COUNTERSUNK HEADSCREW 8.8 M8X25	4	
46	BF2617	PLASTIC PROTECTION CAP M12	3	
47	BF2607	COMP. SPRING FOR CLAMPING STRIP	3	
48	BF2605LW	ALUMINUM CLAMPING STRIP	1	
49	BF0176	WASHER M12X6	3	
50	BF2606	WING BOLT	3	
51	BF0285	TAP BOLT M8X12	3	
52	BF0212	INTERNAL TOOTHING RING M8	8	
53	BF0056	RUBBER BUFFER 30X30 M8	4	
54	BF0124	TAP BOLT M8X10	4	
56	BF2643A	GROUND WIRE FOR STOP SWITCH	1	
57	BF2643	STOP SWITCH .....	1	INCLUDES ITEMS W/#
58#	BF2658	START-STOP DECAL	1	
59	BF0283	CARRIAGE BOLT M8X50	2	
60	BF0089	SELF LOCKING FLANGE NUT M6	2	
63	BF2635	LOWER ALUMINUM CLAMP	2	
65	BF0181	TAP BOLT M6X30 .....	1	REPLACES P/N BF0258
66	BF0100	SELF LOCKING NUT	1	
67	BF2635A	UPPER ALUMINUM CLAMP	2	
68	BF0284	SOCKET HEAD BOLT M6X40	2	
69	BF2636	CLAMP FOR HEIGHT ADJUSTMENT	2	
71	BF0167	SCREW M5X16 .....	1	REPLACES P/N BF0261
72	BF0099	SELF LOCKING NUT M5	1	
73	BF2637LW	SUPPORTING LEG	1	
74	BF2644	GAS THROTTLE ADJUSTMENT BOLT	1	
75	BF2639	CLAMP FOR SUPPORTING LEG	1	
76	BF2634	RUBBER PROTECT CAP FOR SUPPORT LEG	1	
78	BF2321H	SWITCH BRACKET	1	
79	260075LW	LIFTING HANDLE STEEL	1	
80	BF0269	SOCKET HEAD BOLT M5 X12	1	
81	BF0206	SQUARE NUTS M8	8	
82	BF26061	SPRING CLIP, COVER PLATE	1	
83@	BF0217	RETAINING RING .....	1	S/N 0186 AND ABOVE
84@	BF2653	COUPLING DRIVE PIN .....	1	S/N 0186 AND ABOVE
85@	BF2641LOS	CENTRIFUGAL HOUSING W/BEARING .....	1	S/N 0186 AND ABOVE
86	BF2641	CENTRIFUGAL HOUSING COMPLETE .....	1	INCLUDES ITEMS W/@ S/N 0186 AND ABOVE
87@	BF2652	CENTRIFUGAL DRUM .....	1	S/N 0186 AND ABOVE
88@	BF2627	BOLT M12 X 16 .....	1	S/N 0186 AND ABOVE

# ENGINE SERVICE PARTS

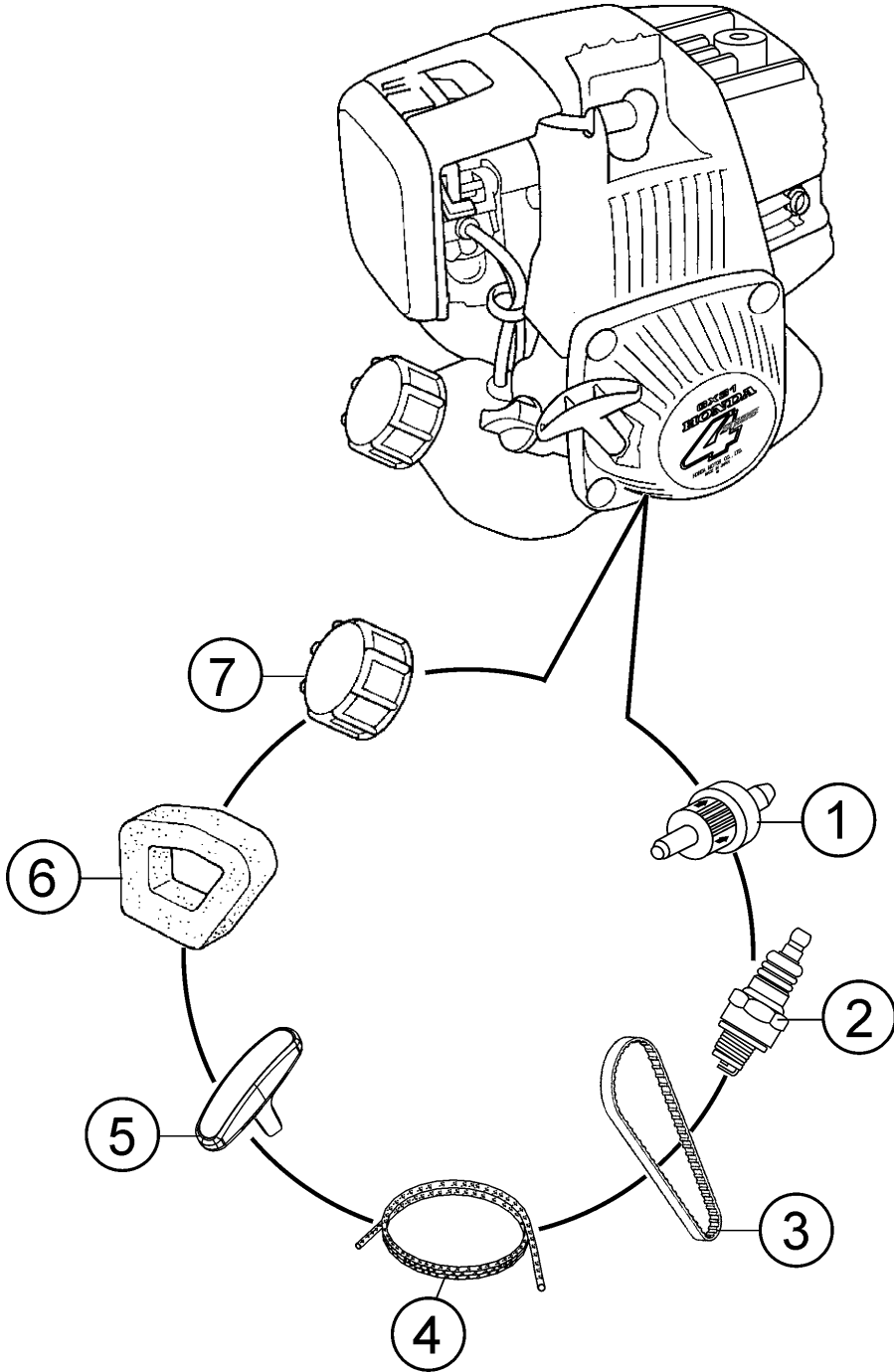

## ENGINE SERVICE PARTS

---

<u>NO.</u>	<u>PART NO.</u>	<u>PART NAME</u>	<u>QTY.</u>	<u>REMARKS</u>
1	17672ZM3003	FILTER, FUEL	1	
2	31915Z0H003	SPARK PLUG, NGK	1	
3	14400Z0Z003	BELT, TIMING 76ZU7 G-300	1	
4	28462ZM3003	ROPE, RECOIL STARTER #3.5X40"	1	
5	28461ZM3003	KNOB, RECOIL STARTER	1	
6	17211Z0Z000	ELEMENT, AIR CLEANER	1	
7	17620ZM3043	CAP ASSY., FUEL TANK	1	

# PARTS MANUAL

## HERE'S HOW TO GET HELP

PLEASE HAVE THE MODEL AND SERIAL  
NUMBER ON-HAND WHEN CALLING

### UNITED STATES

#### *Multiquip Inc.*

(310) 537- 3700  
6141 Katella Avenue Suite 200  
Cypress, CA 90630  
E-MAIL: [mq@multiquip.com](mailto:mq@multiquip.com)  
WEBSITE: [www.multiquip.com](http://www.multiquip.com)

---

### CANADA

#### *Multiquip*

(450) 625-2244  
4110 Industriel Boul.  
Laval, Quebec, Canada H7L 6V3  
E-MAIL: [infocanada@multiquip.com](mailto:infocanada@multiquip.com)

### UNITED KINGDOM

#### *Multiquip (UK) Limited Head Office*

0161 339 2223  
Unit 2, Northpoint Industrial Estate, Globe Lane,  
Dukinfield, Cheshire SK16 4UJ  
E-MAIL: [sales@multiquip.co.uk](mailto:sales@multiquip.co.uk)

© COPYRIGHT 2023, MULTIQIP INC.

Multiquip Inc, the MQ logo are registered trademarks of Multiquip Inc. and may not be used, reproduced, or altered without written permission. All other trademarks are the property of their respective owners and used with permission.

This manual MUST accompany the equipment at all times. This manual is considered a permanent part of the equipment and should remain with the unit if resold.

The information and specifications included in this publication were in effect at the time of approval for printing. Illustrations, descriptions, references and technical data contained in this manual are for guidance only and may not be considered as binding. Multiquip Inc. reserves the right to discontinue or change specifications, design or the information published in this publication at any time without notice and without incurring any obligations.





## Flextool

1956 Dandenong Road, Clayton VIC 3168, Australia

Phone (AUS): 1300 353 986

[flextool.com.au](http://flextool.com.au)

ABN 80 069 961 968

This manual summarises our best knowledge of the product based on the information available at the time of publication. You should read this manual carefully and consider the information in the context of how the product will be used. Our responsibility for products sold is subject to our standard terms and conditions of sale.

### DISCLAIMER:

Any advice, recommendation, information, assistance or service provided by us in this manual is given in good faith and is believed by us to be appropriate and reliable. However, any advice, recommendation, information, assistance or service provided by us is provided without liability or responsibility PROVIDED THAT the foregoing shall not exclude, limit, restrict or modify the right entitlements and remedies conferred upon any person or the liabilities imposed upon us by any condition or warranty implied by Commonwealth, State or Territory Act or ordinance void or prohibiting such exclusion limitation or modification. The product can be expected to perform as indicated in this manual so long as operation and operational procedures of the individual products are followed as recommended in this manual.

Design and technical specifications may be subject to changes.

© This publication is copyright. All rights are reserved. Flextool is a registered trade mark of Parchem Construction Supplies Pty Ltd. Multiquip, MQ and Whiteman are registered trade marks of Multiquip Inc.