



# SPARE PARTS MANUAL

## FLEXTOOL PRESSURE CLEANER FPC-4000



Version 1.0 (February 2026)

FOR MORE INFORMATION VISIT [flextool.com.au](https://flextool.com.au)

## HOW TO READ THIS SPARE PARTS MANUAL

The following section explains the different symbols and remarks used in this manual and how to interpret the information outlined in the following pages.

### Section 1 – Diagram and parts list

- Item No : Used to reference the spare part in the diagram to the parts list.
- Product Code : Used to indicate the unique Flextool spare parts product code used when ordering parts.

Product code can be presented in the following ways:

- Number : Signifies the unique Flextool spare parts product code used when placing orders.
  - Blank : Used for parts pending formal part number assignment at the time of publication. Also denotes that the spare parts are not sold separately or are unavailable from Flextool.
  - See remarks : Indicates that the spare parts are part of an assembly, service kit or is part of a serial number range where a particular part is used. Please refer to remarks to find further information.
- Description : Used to provide a concise description of the spare part such as size, length, diameter, models, etc.
  - Qty : Indicates the quantity of part(s) required for the equipment. Please verify the required quantity when placing an order.
  - Remarks : Refers to additional information, including assembly kit, service kit and serial number range where particular part is used
    - AS : Refers to the parts supplied with an assembly kit.
    - SK : Refers to the parts supplied with a service kit.
    - Serial number: Indicates the range of serial number where particular part is used.

### Section 2 – Fast moving spare parts

#### FLEXTOOL PRESSURE CLEANER FPC-4000

Description	Product Code
FLX RUBBER GROMMETS KITS	NPS03463-UNIT
FLX HOSE HOOK KIT	NPS03483-UNIT

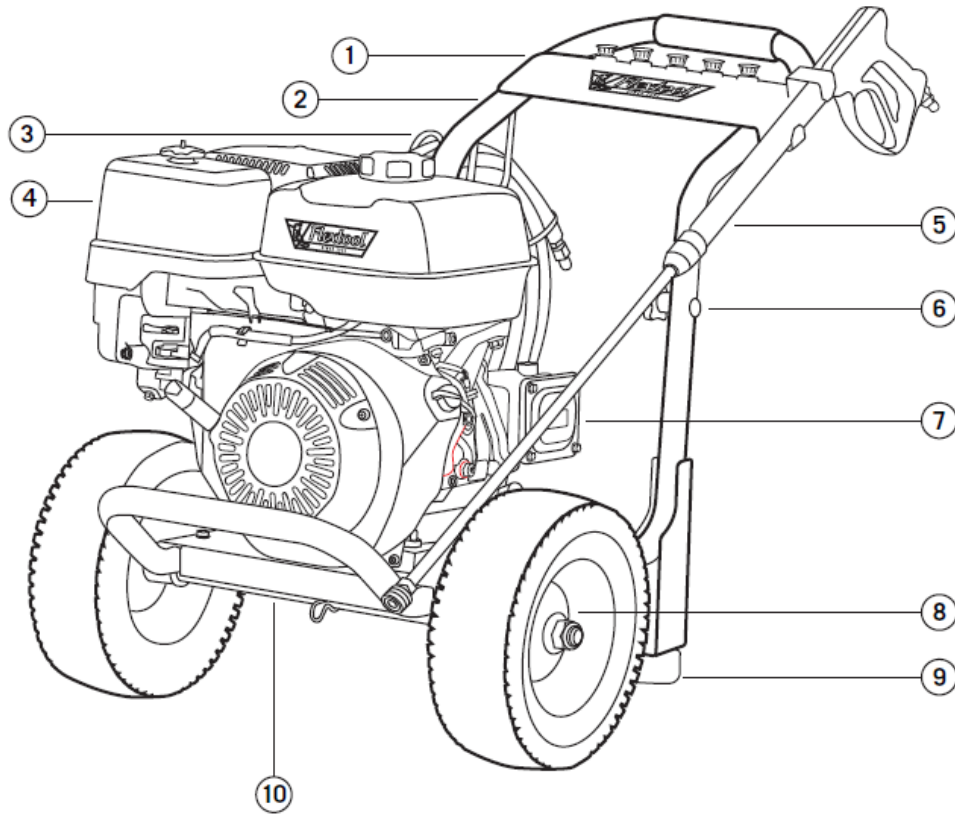

**PRESSURE CLEANER**

Item No.	Product Code	Description	Qty	Remarks
1A	FT2HIJ10-UNIT	FLX PRESSURE CLEANER NOZ KIT 5PC 4000PSI (HIJ-AB9740)	1	
1B	NPS03463-UNIT	FLX RUBBER GROMMETS KITS (HIJ-BG5039)	1	
1C	NPS03465-UNIT	FLX STRAP ASSEMBLY KIT (HIJ-BG21690)	1	
2	NPS03480-UNIT	FLX FRAME UPPER SECTION (HIJ-BG21650+BG5043)	1	
3A	FT2HIJ05-UNIT	FLX PRESSURE CLEANER HOSE ASSY 15M (HIJ-AN1650CP)	1	
3B	NPS03483-UNIT	FLX HOSE HOOK KIT (HIJ- BG20740KIT)	1	
4		HON ENGINE GX360	1	
5A	FT2HIJ03-UNIT	FLX PRESSURE CLEANER TRIGGER (HIJ-AC7015P)	1	
5B	FT2HIJ04-UNIT	FLX PRESSURE CLEANER LANCE UPPER SECTION (HIJ-DC3112)	1	
6	NPS03466-UNIT	FLX KNOB KIT (HIJ-BG5038+D12476)	1	
7	NPS03518-UNIT	FLX PUMP ASSY (HIJ-RSV4G40)	1	
8A	NPS03467-UNIT	FLX WHEEL (HIJ-BG6204MB)	1	
8B	NPS03469-UNIT	FLX AXLE (HIJ-BG2287)	1	
8C	NPS03470-UNIT	FLX NUT KIT (HIJ-D23601+D33604)	1	
9A	NPS03485-UNIT	FLX FRAME FOOT EXTENSION (HIJ- BG21220)	1	
9B	NPS03486-UNIT	FLX RUBBER MOUNT KIT (HIJ-BG5041KIT)	1	
10	NPS03472-UNIT	FLX FRAME ENGINE MOUNT (HIJ-BG2168)	1	

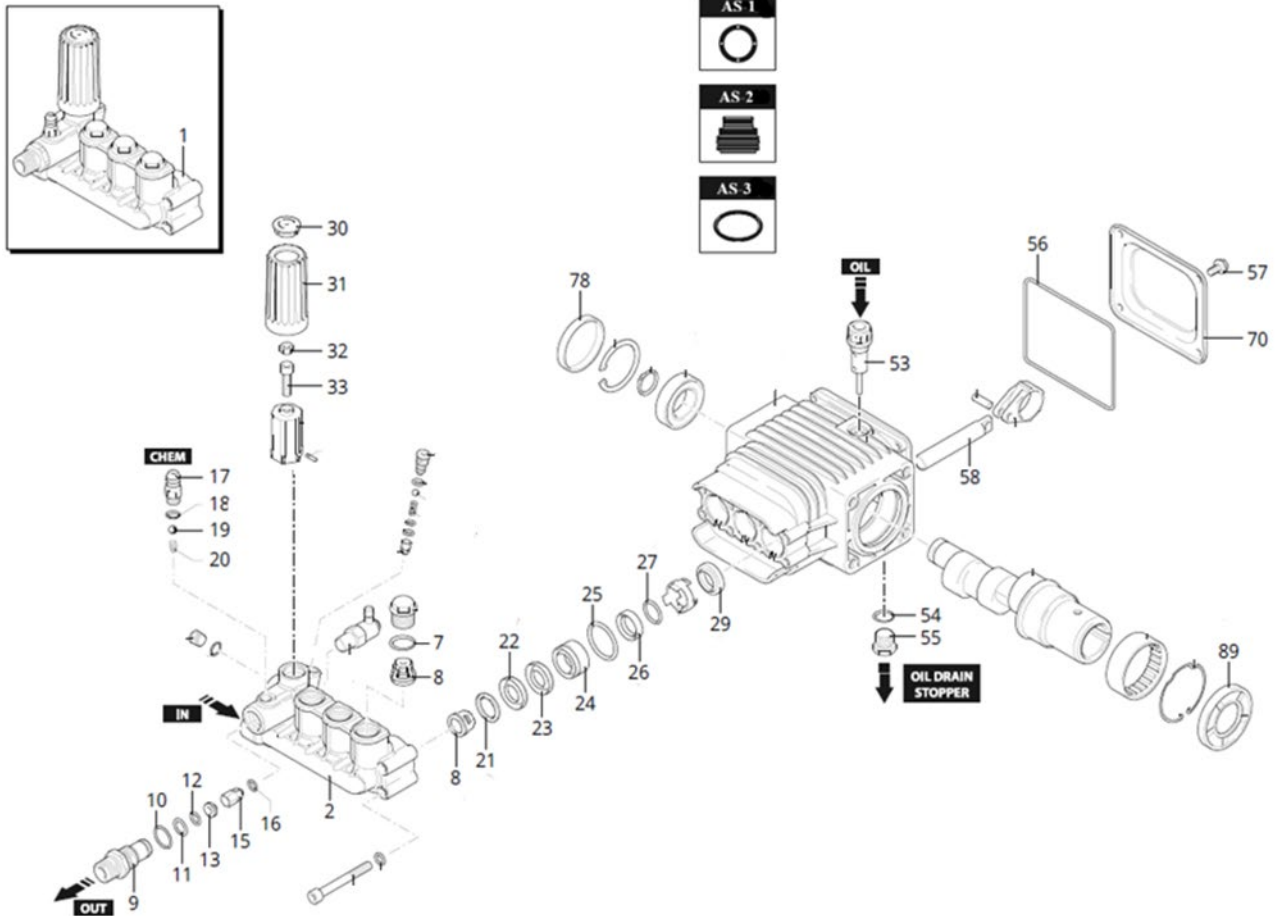

**PUMP PARTS**

Item No.	Product Code	Description	Qty	Remarks
1		FLX HEAD ASSEMBLY 15 (HIJ-2769246)	1	
7	See Remarks	FLX O-RING 15.6X1.78 (HIJ-1200690)	3	Use AS-3
8	NPS03567-UNIT	FLX COMPLETE VALVE KIT (HIJ-42666)	6	
9	NPS03574-UNIT	FLX FITTING 3/8" G (HIJ-2760230)	1	
10	See Remarks	FLX O-RING 12.42X1.78 (HIJ-394280)	1	Use AS-3
11	See Remarks	FLX O-RING 12X1 (HIJ-2760270)	1	Use AS-3
12	See Remarks	FLX O-RING 9X1 (HIJ-1470210)	1	Use AS-3
16	See Remarks	FLX O-RING 4X2.5 (HIJ-2101770)	1	Use AS-3
18	See Remarks	FLX O-RING 4.48X1.78 (HIJ-480480)	1	Use AS-3
19	See Remarks	FLX BALL (HIJ-1250280)	1	Use AS-3
20	See Remarks	FLX SPRING (HIJ-1560520)	1	Use AS-3
21	NPS03573-UNIT	FLX SUPPORT RING KIT (HIJ-2760220)	3	
22	See Remarks	FLX WATER SEAL 15 (HIJ-1342761)	3	Use AS-2
23	See Remarks	FLX RING (HIJ-1981580)	3	Use AS-2
24		FLX PISTON GUIDE 15 (HIJ-1981570)	3	
25	See Remarks	FLX O-RING 23.52X1.78 (HIJ-770260)	3	Use AS-2
26	See Remarks	FLX WATER SEAL 15 (HIJ-1260440)	3	Use AS-2
27	See Remarks	FLX O-RING 13.95X2.62 (HIJ-640070)	3	Use AS-2
29	See Remarks	FLX OIL SEAL (HIJ-1260460)	3	Use AS-1
30	NPS03575-UNIT	FLX PLUG (HIJ-1981770)	1	
31	NPS03576-UNIT	FLX KNOB (HIJ-1981780)	1	
32	NPS03577-UNIT	FLX NUT M6 (HIJ-1060120)	1	
33	NPS03578-UNIT	FLX SCREW M6X25 (HIJ-2840970)	1	
53	NPS03579-UNIT	FLX OIL PLUG W DIPSTICK (HIJ-880130)	1	
54	NPS03580-UNIT	FLX O-RING 14X1.78 (HIJ-740290)	1	
55	NPS03581-UNIT	FLX PLUG 3/8" (HIJ-2841240)	1	

## PUMP PARTS CONTINUED

Item No.	Product Code	Description	Qty	Remarks
56	See Remarks	FLX O-RING (HIJ-2760281)	1	Use AS-1
57	NPS07515-UNIT	FLX SCREW 6X12 (HIJ-802190)	4	
58	NPS03569-UNIT	FLX PISTON KIT (HIJ-2760040)	3	
78	See Remarks	FLX COVER (HIJ-1266740)	1	Use AS-1
89	See Remarks	FLX RING SEAL (HIJ-480671)	1	Use AS-1

## PUMP PARTS KITS

Item No.	Product Code	Description	Qty	Remarks
AS-1	NPS03570-UNIT	FLX OIL SEAL KIT (HIJ-2188)	1	Inc Items: 29,56,78 & 89
AS-2	NPS03571-UNIT	FLX WATER SEAL KIT (HIJ-2189)	1	Inc Items: 22,23 & 25-27
AS-3	NPS03572-UNIT	FLX GASKET KIT (HIJ-2190)	1	Inc Items: 7,10-12,18-20,39-41,43,44,47 & 48



## Flextool

1956 Dandenong Road, Clayton VIC 3168, Australia

Phone (AUS): 1300 353 986

[flextool.com.au](http://flextool.com.au)

ABN 80 069 961 968

This manual summarises our best knowledge of the product based on the information available at the time of publication. You should read this manual carefully and consider the information in the context of how the product will be used. Our responsibility for products sold is subject to our standard terms and conditions of sale.

### DISCLAIMER:

Any advice, recommendation, information, assistance or service provided by us in this manual is given in good faith and is believed by us to be appropriate and reliable. However, any advice, recommendation, information, assistance or service provided by us is provided without liability or responsibility PROVIDED THAT the foregoing shall not exclude, limit, restrict or modify the right entitlements and remedies conferred upon any person or the liabilities imposed upon us by any condition or warranty implied by Commonwealth, State or Territory Act or ordinance void or prohibiting such exclusion limitation or modification. The product can be expected to perform as indicated in this manual so long as operation and operational procedures of the individual products are followed as recommended in this manual.

Design and technical specifications may be subject to changes.

© This publication is copyright. All rights are reserved. Flextool is a registered trade mark of Parchem Construction Supplies Pty Ltd.