

HONDA

GENERAL PURPOSE ENGINE

**GX340UT1
GX340UT2
GX340RT1
GX340RT2
GX340UT2X**

PARTS CATALOGUE

9

FOREWORD INDEX

1

ENGINE GROUP

2

PART NUMBER INDEX

3

PART NAME INDEX

4

Instruction for use of parts catalogue

- **This parts catalogue was prepared based on the latest information available as of March 20, 2022.**
 - See the parts catalogue news for any revision that is made after March 20, 2022.
- **Always specify the part number when ordering a part.**
 - Check the model, type, serial numbers, color, maker, and the size as needed before ordering a part.
 - Note that the illustrations (part drawings) can differ from the actual parts in shape. They are given just to help you to refer to the parts.
- **When modifications or additions to this parts catalogue are made, a revised edition will be issued at an appropriate time, with successively progressing revision numbers on the cover. We recommend obtaining such revisions in order to keep your parts catalogue up-to-date at all times. To check whether a parts catalogue revision has been issued, please contact your Honda distributor.**

Initial version issue date December 05, 2008
Honda Motor Co., Ltd.

CONTENTS

	Page
•Instruction for use of parts catalogue	1
•How to refer to the part information	2
•Part catalogue structure.....	3
•When the parts were revised.....	4
•Abbreviations used in the parts catalogue.....	4
•How to check the part block and serial numbers.....	5
•Models, parts catalogue codes and applicable serial numbers	6
•Features of each type.....	11
•Fuel hose, general purpose hoses and vinyl hose.....	22
•Illustrated index	23
•ENGINE GROUP.....	28
•PART NO. INDEX.....	145
•PART NAME INDEX.....	149

1

2

3

4

1

How to refer to the part information

A Reference with "Illustrated index"

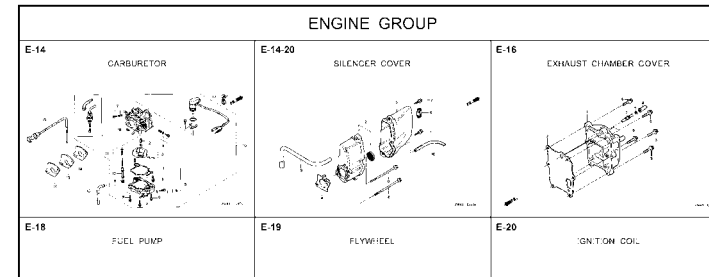

B Reference with "Part number index"

PART NO. INDEX				
Part Number	Page Ref.	Part Number	Page Ref.	Pi
06000		15212-ZW9-000	49 7	17583
		15220-ZW9-003	49 8	17583
06316-ZW9-000	104 1	15332-ZW9-000	74 2	17611
		15332-ZW9-A30	76 2	17611
11000		15400-PFB-004	46 5	17612
		15422-ZW9-000	49 9	17620
11300-ZW9-000	46 1	15473-881-000	49 10	17620
11300-ZW9-800	46 1	15474-ZW9-000	49 11	17624
11340-ZW9-000	46 2	15611-921-000	45 6	17650
11342-ZW9-000	46 3	15655-ZW9-000	46 6	17660
11381-ZW9-003	47 1			17661
12000		16000		
12000-ZW9-000ZA	46 4	16010-ZV4-005	55 1	17665
12155-ZV4-A00	48 1	16011-ZV4-005	55 2	17670
12166-ZW9-000	45 1	16013-ZW9-003	55 3	17680
12209-GB4-681	51 1	16016-ZW9-003	55 4	17701
12209-GB4-681	51 1	16016-ZW9-721	55 4	17701
12210-ZW9-000ZA	45 2	16023-ZW9-005	55 5	17701
12216-ZE2-300	74 1	16024-ZV4-650	55 6	17701
		16028-ZV4-650	55 7	17702

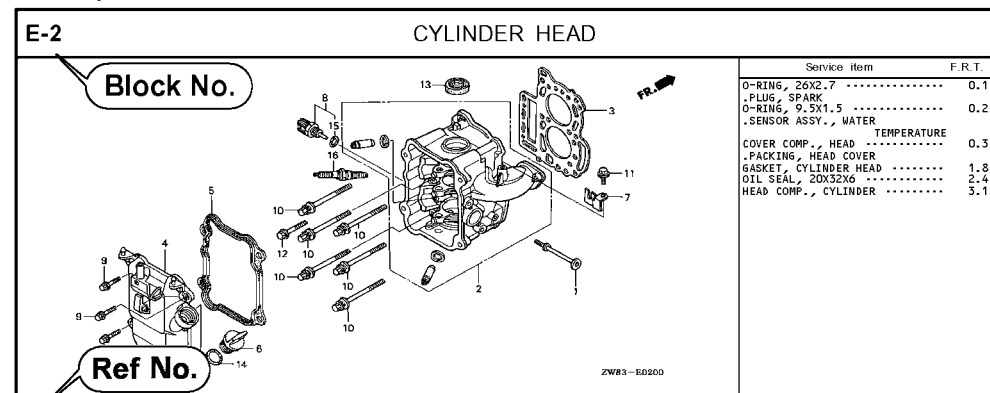

C Reference with "Part name index"

PART NAME INDEX		
Part name	Page	Ref.
[A]		
ABSORBER, FUEL	80	5
ARMATURE COMP.	62	7
ARM COMP., LINK JOINT	102	18
ARM COMP., SHIFT LINK	102	14
ARM COMP., TILT	97	20
ARM, FUEL PUMP ROCKER	51	4
ARM, REVERSE LOCK	97	18
ARM, SHIFT LINK	92	7
ARM, STOPPER	52	12
ARM, THROTTLE REMOTE	92	6
ARM, VALVE ROCKER	51	3
[B]		
BAG, TOOL, 160MM	101	10
BAND	103	37
BAND B1, WIRE	87	1
BAND, CORD	85	18
BAND, TUBE CLIP, 11MM	81	20
BAND, TUBE CLIP, 12.5MM	81	19

Ref. No.	Part No.	Description	Reqd. QTY						Serial No.	Parts catalogue code
			9901	9901	1001	1001	1001	1001		
1	12166-ZW9-000	STOPPER, ENGINE SIDE	2	2	2	2	2	2		
2	12210-ZW9-000ZA	HEAD COMP., CYLINDER	1	1	1	1	1	1		
3	12251-ZW9-003	GASKET, CYLINDER HEAD	1	1	1	1	1	1		
4	12310-ZW9-000	COVER COMP., HEAD	1	1	1	1	1	1		
5	12312-ZW9-000	PACKING, HEAD COVER	1	1	1	1	1	1		
6	15611-921-000	CAP, OIL (NO GAUGE)	1	1	1	1	1	1		
7	16617-ZW9-000	HOLDER, CABLE	1	1	1	1	1	1	SC,SG	
	16617-ZW9-010		1	1	1	1	1	1	1001800 LHC,LHD	
			1	1	1	1	1	1	1001801 LHC,LHD	
8	35673-ZW5-003	SENSOR ASSY., WATER	1	1	1	1	1	1		
9	90003-ZW9-000	BOLT, FLANGE, 6X22	6	4	4	4	4	4		
10	90007-ZW9-003	BOLT, FLANGE, 8X83	6	6	6	6	6	6		
11	90011-ZW9-000	BOLT, FLANGE, 6X14 (CT200)	1	1	1	1	1	1		
12	90020-ZW9-000	BOLT, FLANGE, 8X40	2	2	2	2	2	2		
13	91202-KJ9-003	OIL SEAL, 20X32X6	1	1	1	1	1	1		
14	91301-805-000	O-RING, 26X2.7	1	1	1	1	1	1		
15	91307-PK2-005	O-RING, 9.5X1.5 (HONDA KIKAKI)	1	1	1	1	1	1		
16	98059-55916	PLUG, SPARK (CR5EH-9)	2	2	2	2	2	2		
	98059-55926	PLUG, SPARK (U16FER9)	2	2	2	2	2	2		

Page No.

2000.09.20 E

Part catalogue structure

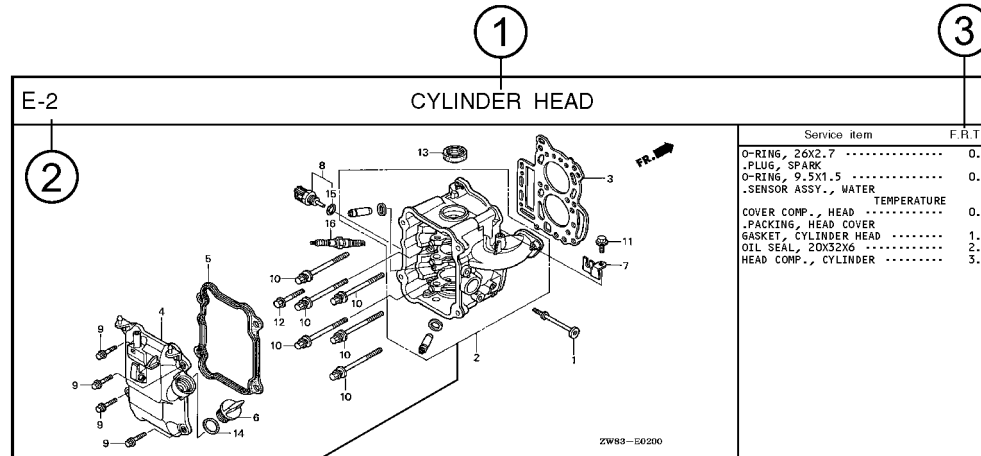

Ref. No.	Part No.	Description	Reqd. QTY						Serial No.	Parts catalogue code
			BF 9.9D1	BFP 9.9D1	BF 10D1	BFP 10D1	BF 10B1	BFP 10B1		
1	12166-zw9-000	STOPPER, ENGINE SIDE	2	2	2	2	2	2		
2	12210-zw9-000ZA	HEAD COMP., CYLINDER *NH8*.....DARK GRAY	1	1	1	1	1	1		
3	12251-zw9-003	GASKET, CYLINDER HEAD	1	1	1	1	1	1		
4	12310-zw9-000	COVER COMP., HEAD	1	1	1	1	1	1		
5	12312-zw9-000	PACKING, HEAD COVER	1	1	1	1	1	1		
6	15611-921-000	CAP, OIL (NO GAUGE)	1	1	1	1	1	1		
7	16617-zw9-000	HOLDER, CABLE	1	1	1	1	1	1	SC,SG	
	16617-zw9-010		1	1	1	1	1	1	1001800 LHC,LHD	

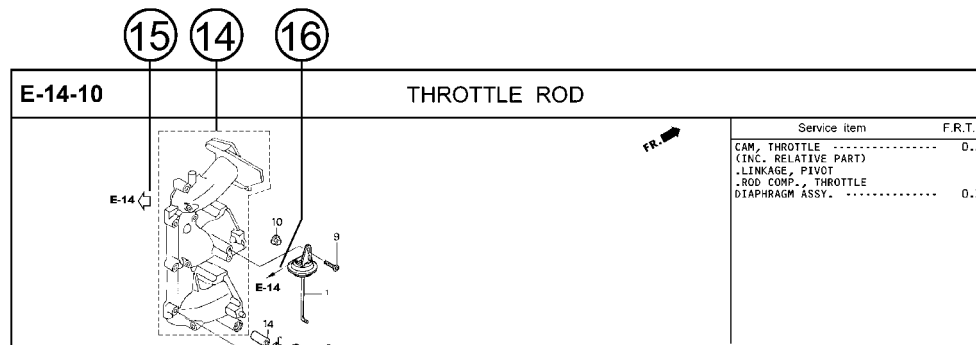

① Block title ② Block number

③ Service item/Flat rate time

④ Reference number

- Title number marked with the parenthesis or parentheses indicates that it continues from the previous page.

⑤ Part number ⑥ Honda color code

⑦ Description

⑧ Assemblies

- Sections framed with broken lines in the exploded view drawings are available as complete assemblies. (Their individual parts can also be obtained.)

⑨ Color description

⑩ Note

- Notes are shown with the parentheses in the part name column.

⑪ Required quantity

- Required QTY shown in the parenthesis or parentheses indicates the optional part.
- Required QTY marked with "N" Indicates the optional part that should be selected as needed.
- Required QTY indicates the number of the part used in the block.

⑫ Serial number

⑬ Type

- When the type column is blank, it indicates that the part is applicable to all types.
- As the type of the actual unit may differ from the "parts catalogue, type" please refer to "Models, types and applicable serial numbers" for confirmation.

⑭

- Parts enclosed within a dotted line are covered in a different block.

⑮

- A hollow arrow indicates the block No. for the parts enclosed within a dotted line.

⑯

- A solid arrow indicates the block No. the part in question is connected to.

When the parts were revised



Be sure to check the serial number!!



Ref. No.	Part No.	Description	Reqd. QTY						Serial No.
			BF 99D1	BFP 9.9D1	BF 10D1	BFP 10D1	BF 10B1	BFP 10B1	
1	12166-ZW9-000	STOPPER, ENGINE SIDE	2	2	2	2	2	2	
2	12210-ZW9-000ZA	HEAD COMP., CYLINDER *NH8*.....DARK GRAY	1	1	1	1	1	1	
3	12251-ZW9-003	GASKET, CYLINDER HEAD	1	1	1	1	1	1	
4	12310-ZW9-000	COVER COMP., HEAD	1	1	1	1	1	1	
5	12312-ZW9-000	PACKING, HEAD COVER	1	1	1	1	1	1	
6	15611-921-000	CAP, OIL (NO GAUGE)	1	1	1	1	1	1	
7	16617-ZW9-000	HOLDER, CABLE (###).....	1	1	1	1	1	1	
	16617-ZW9-010	1	1	1	1	1	1	

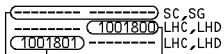

The number has been used from the initial model without revision. When shown at the left side, it is applicable to the models of No.1001801 and the subsequent numbers. When shown at the right side, it is applicable to the models up to No.1001800.

• The parts listed with "###" at the end of the parts name have limited supply period (parts not for sale).

Abbreviations used in the parts catalogue

• The following abbreviations are used in the parts name column.

- AAmpere
- A.C.Alternating current
- ASSY.Assembly
- AT.Automatic transmission
- C.D.I.Capacitive discharge ignition
- COMP.Complete
- D.C.Direct current
- EX.Exhaust
- G.F.C.IGround fault circuit interruptor
- HEX.Hexagonal
- H.S.T.Hydrostatic transmission
- FR.Front
- IN.Inlet
- L (100L) ... Link (100 Links)
- L.Left
- MMMillimeter
- MT.Manual Transmission
- P.T.O.Power take off
- R.Right
- RR.Rear
- STD.Standard
- T (22T) Tooth (22 Teeth)
- VVolt
- WWatt

How to check the part block and serial numbers

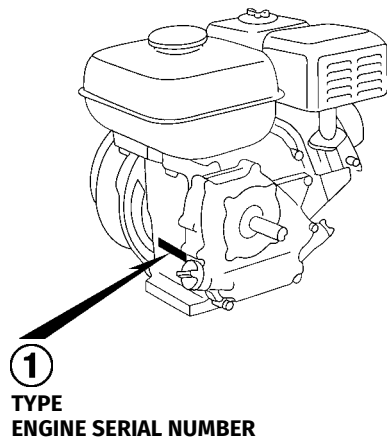
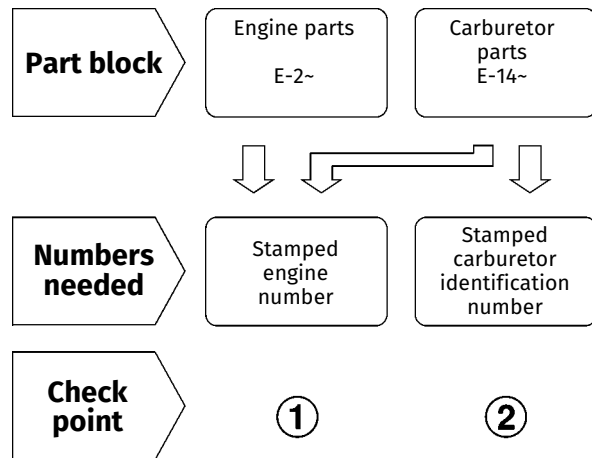

②-B
CARBURETOR IDENTIFICATION
NUMBER
EXCEPT GX340UT2-QZA2 / QZAV /
QZN2 / QZX4 TYPES

②-A
CARBURETOR IDENTIFICATION
NUMBER
EXCEPT GX340UT2-QZA2 / QZAV /
QZN2 / QZX4 TYPES

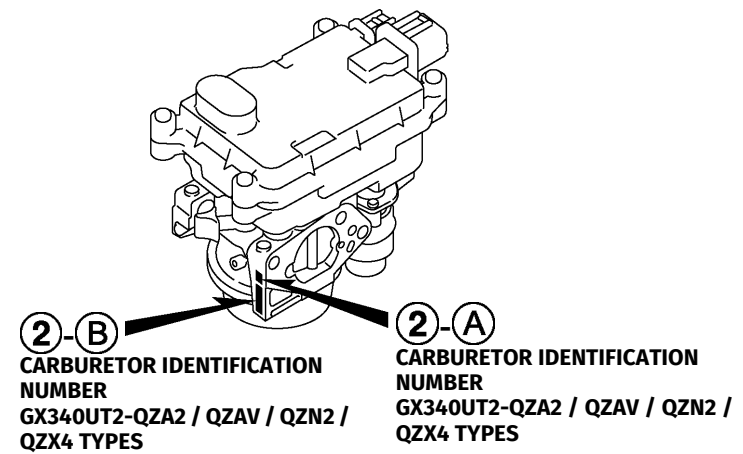
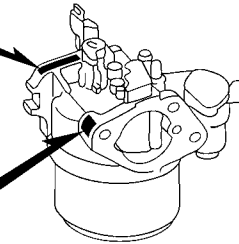

Models, parts catalogue codes and applicable serial numbers

• Models, parts catalogue codes and applicable serial Nos. given in this parts catalogue can be identified as follows.

Model	Type	Parts catalogue type	Applicable engine serial No.	Applicable carburetor identification No.	Model	Type	Parts catalogue type	Applicable engine serial No.	Applicable carburetor identification No.
GX340UT1	HA2	HA2	GCAVT-1000001~9999999	BE80J A	GX340UT1	QHB4	QHB4	GCAVT-1000001~9999999	BE80J A
	HX26	HX26				QHQ4	QHQ4		BE94C A
	LX2	LX2				QKA4	QKA4		BE80J A
	LXE4	LXE4				QNE2	QNE2		
	LXE8	LXE8				QNR2	QNR2		
	LXQ4	LXQ4				QNR6	QNR6		
	LXU	LXU				QXB7	QXB7		BE94D A
	PKT2	PKT2				QXB9	QXB9		
	QA2	QA2				QXC4	QXC4		BE80L A
	QA26	QA26				QXC6	QXC6		BE80J A
	QAE2	QAE2				QXC9	QXC9		
	QAE6	QAE6				QXE4	QXE4		
	QAG	QAG				QXE6	QXE6		
	QAH2	QAH2		QXE8		QXE8			
	QAP2	QAP2		QXQ4		QXQ4	BE80J A		
QDW9	QDW9	QXU	QXU						
QE	QE	SE	SE						
				BE80L A					
				BE80J A					

Model	Type	Parts catalogue type	Applicable engine serial No.	Applicable carburetor identification No.
GX340UT1	SHQ4	SHQ4	GCAVT-1000001~9999999	BE80J A
	SME0	SME0		
	SXE4	SXE4		
	SXE8	SXE8		
	SXQ4	SXQ4		
	VA2	VA2		
	VX16	VX16		BE80K A
	VX8	VX8		BE80J A
	VXB7	VXB7		BE80K A
	VXB9	VXB9		
	VXE2	VXE2		
	VXE7	VXE7		
	VXE8	VXE8		
VXE9	VXE9			
GX340UT2	HA2	HA2	GCBET-1000001~1999999	BE80M A
		HA2/A	GCBET-2000001~2025452	BE80Z A
	HX26	HX26	GCBET-1000001~1999999	BE80M A
		HX26/A	GCBET-2000001~2025452	BE80Z A
	LX2	LX2	GCBET-1000001~9999999	BE80M A

Model	Type	Parts catalogue type	Applicable engine serial No.	Applicable carburetor identification No.
GX340UT2	LXE4	LXE4	GCBET-1000001~9999999	BE80M A
		LXQ4	GCBET-1000001~1999999	
	LXQ4	LXQ4	GCBET-2000001~2025452	BE80Z A
		LXQ4/A	GCBET-2000001~2025452	BE80Z A
	LXU	LXU	GCBET-1000001~9999999	BE80M A
		LXU	GCBET-1000001~9999999	
	PKT2	PKT2	GCBET-1000001~1999999	BE80Z A
		PKT2/A	GCBET-2000001~2025452	
	PKX2	PKX2	GCBET-1000001~1999999	BE80M A
		PKX2/A	GCBET-2000001~2025452	BE80Z A
	QA2	QA2	GCBET-1000001~1999999	BE80M A
		QA2/A	GCBET-2000001~	BE80Z A
	QAE2	QAE2	GCBET-1000001~1999999	BE80M A
		QAE2/A	GCBET-2000001~2025452	BE80Z A
	QAE6	QAE6	GCBET-1000001~1999999	BE80M A
		QAE6/A	GCBET-2000001~2025452	BE80Z A
	QAG	QAG	GCBET-1000001~9999999	BE80M A
		QAG	GCBET-1000001~9999999	
	QAH2	QAH2	GCBET-1000001~1999999	BE80Z A
		QAH2/A	GCBET-2000001~2025452	
	QAP2	QAP2	GCBET-1000001~1999999	BE80M A
		QAP2/A	GCBET-2000001~2025452	BE80Z A



Model	Type	Parts catalogue type	Applicable engine serial No.	Applicable carburetor identification No.
GX340UT2	QDW9	QDW9	GCBET-1000001~9999999	BE80Q A
	QE	QE	GCBET-1000001~1999999	BE80M A
		QE/A	GCBET-2000001~2025452	BE80Z A
	QHB4	QHB4	GCBET-1000001~1999999	BE80M A
		QHB4/A	GCBET-2000001~2025452	BE80Z A
	QHQ4	QHQ4	GCBET-1000001~9999999	BE80M A
	QKA4	QKA4	GCBET-1000001~1999999	BE80P A
		QKA4/A	GCBET-2000001~2025452	BE80Z A
	QMT2	QMT2	GCBET-1000001~1999999	BE80M A
		QMT2/A	GCBET-2000001~2025452	BE80Z A
	QNE2	QNE2	GCBET-1000001~1999999	BE80M A
		QNE2/A	GCBET-2000001~	BE80Z A
	QNR2	QNR2	GCBET-1000001~1999999	BE80M A
		QNR2/A	GCBET-2000001~2025452	BE80Z A
	QWC	QWC	GCBET-1000001~1999999	BE80M A
		QWC/A	GCBET-2000001~2025452	BE80Z A
	QXB7	QXB7	GCBET-1000001~1999999	BE80M A
		QXB7/A	GCBET-2000001~2025452	BE80Z A
	QXB9	QXB9	GCBET-1000001~9999999	BE80M A

Model	Type	Parts catalogue type	Applicable engine serial No.	Applicable carburetor identification No.
GX340UT2	QXC9	QXC9	GCBET-1000001~	BE80Q A
	QXE4	QXE4	GCBET-1000001~1999999	BE80M A
		QXE4/A	GCBET-2000001~2025452	BE80Z A
	QXE6	QXE6	GCBET-1000001~9999999	BE80M A
	QXE8	QXE8		
	QXQ4	QXQ4	GCBET-1000001~1999999	BE80Z A
		QXQ4/A	GCBET-2000001~2025452	
	QXU	QXU	GCBET-1000001~1999999	BE80M A
		QXU/A	GCBET-2000001~9999999	
	QZA2	QZA2	GCBET-1000001~9999999	BE91A A
	QZAV	QZAV		
	QZN2	QZN2		
	QZX4	QZX4		
	SE	SE	GCBET-1000001~1999999	BE80M A
		SE/A	GCBET-2000001~2025452	BE80Z A
	SE1	SE1		
	SE2	SE2		
	SHQ4	SHQ4	GCBET-1000001~1999999	BE80M A
		SHQ4/A	GCBET-2000001~9999999	BE80Z A

Model	Type	Parts catalogue type	Applicable engine serial No.	Applicable carburetor identification No.
GX340UT2	SME0	SME0	GCBET-1000001~1999999	BE80M A
		SME0/A	GCBET-2000001~2025452	BE80Z A
	SMX2	SMX2	GCBET-1000001~9999999	BE80M A
		SXE4	GCBET-1000001~1999999	
	SXE4	SXE4/A	GCBET-2000001~2025452	BE80Z A
		SXE8	GCBET-1000001~9999999	BE80M A
	SXQ4	SXQ4	GCBET-1000001~1999999	
		SXQ4/A	GCBET-2000001~2025452	BE80Z A
	VA2	VA2	GCBET-1000001~9999999	BE80N A/B
	VX16	VX16	GCBET-1000001~1999999	BE80M A
		VX16/A	GCBET-2000001~9999999	BE80Z A
	VX8	VX8	GCBET-1000001~1999999	BE80N A/B
		VX8/A	GCBET-2000001~2025452	BE80Z A
	VXB7	VXB7	GCBET-1000001~9999999	BE80N A/B
	VXB9	VXB9		
	VXE2	VXE2	GCBET-1000001~1999999	BE80N B
		VXE2/A	GCBET-2000001~9999999	
	VXE8	VXE8	GCBET-1000001~1999999	BE80N A/B
VXE8/A		GCBET-2000001~2025452	BE80Z A	

Model	Type	Parts catalogue type	Applicable engine serial No.	Applicable carburetor identification No.
GX340UT2	VXE9	VXE9	GCBET-1000001~9999999	BE80N A/B
GX340RT1	QNB2	QNB2	GCAVT-1000001~9999999	BE80J A
	VAD2	VAD2		BE80D B/C
	VC2	VC2		BE82T A
	VDE2	VDE2		BE80D B/C
	VW12	VW12		
	VWC	VWC		BE82M B
	VVE	VVE		
	VWE2	VWE2		BE80D B/C
GX340RT2	EDE2	EDE2	GCBET-1000001~1999999	BE82V A
		EDE2/A	GCBET-2000001~	BEA5C B
	EDN2	EDN2	GCBET-1000001~1999999	BE82V A
		EDN2/A	GCBET-2000001~	BEA5C B
	EDS6	EDS6	GCBET-1000001~1999999	BE82V A
		EDS6/A	GCBET-2000001~	BEA5C B
	EDT6	EDT6	GCBET-1000001~1999999	BE82V A
		EDT6/A	GCBET-2000001~	BEA5C B
	QNB2	QNB2	GCBET-1000001~9999999	BE80M A BE80Y A
	VDE2	VDE2		BE80N A/B



Model	Type	Parts catalogue type	Applicable engine serial No.	Applicable carburetor identification No.	Model	Type	Parts catalogue type	Applicable engine serial No.	Applicable carburetor identification No.
GX340RT2	VWC	VWC	GCBET-1000001~1999999	BE82V A	GX340UT2X	QE	QE	GCBET-2025453~	BE80Z A
		VWC/A	GCBET-2000001~	BEA5C B		QHB4	QHB4		
	VWE	VWE	GCBET-1000001~1999999	BE82V A		QKA4	QKA4		
		VWE/A	GCBET-2000001~	BEA5C B		QMT2	QMT2		
	VWE2	VWE2	GCBET-1000001~1999999	BE80N A/B		QNE2	QNE2	GCBET-2000001~	
		VWE2/A	GCBET-2000001~	BE80W A/B		QNR2	QNR2	GCBET-2025453~	
	VWS	VWS	GCBET-1000001~9999999	BE82V A		QWC	QWC		
	VWS1	VWS1	GCBET-1000001~1999999	BEA5B B		QXB7	QXB7		
		VWS1/A	GCBET-2000001~	BEA5C B		QXE4	QXE4		
	GX340UT2X	HA2	HA2	GCBET-2025453~		BE80Z A	QXQ4		
HX26		HX26	SE		SE				
LXQ4		LXQ4	SE1		SE1				
PKT2		PKT2	SE2		SE2				
PKX2		PKX2	SME0		SME0				
QA2		QA2	GCBET-2000001~	SXE4	SXE4				
QAE2		QAE2	GCBET-2025453~	SXQ4	SXQ4				
QAE6		QAE6		VX8	VX8				
QAH2		QAH2		VXE8	VXE8				
QAP2		QAP2							

* Of carburetor identification numbers, only the portions underlined in the example below are used for registration.

BE 80J A KC ナ
 (A) (B)

Features of each type

• See the following table for the features of each type. (Items in brackets are optional)

Specifications		Model Type	GX340UT1													
			HA2	HX26	LX2	LXE4	LXE8	LXQ4	LXU	PKT2	QA2	QA26	QAE2	QAE6	QAG	QAH2
Crankshaft	25mm Ø Straight															
	25.4mm Ø Straight									●	●	●	●	●	●	●
	20mm Ø Spline	●	●													
	30mm Ø Spline			●	●	●	●	●								
	3/16 Tapered															
	1/5 Tapered															
	1" Thread								●							
Air cleaner	Silent	●	●	●	●	●	●	●	●	●	●	●	●	●	●	●
	Cyclone															
	Generator															
Muffler	Standard	●	●	●	●	●	●	●	●	●	●	●	●	●	●	●
	Silent															
Spark arrester		●	(●)	(●)	(●)	(●)	(●)	(●)	(●)	●	●	●	●	●	●	●
Oil alert		●	●	●	●	●	●	●	●	●	●	●	●	●	●	●
Starter motor					●	●						●	●			
Reduction		●	●	●	●	●	●	●								

Specifications		Model	GX340UT1													
		Type	QDW9	QE	QHB4	QHQ4	QKA4	QNE2	QNR2	QNR6	QXB7	QXB9	QXC4	QXC6	QXC9	QXE4
Crankshaft	25mm Ø Straight															
	25.4mm Ø Straight	●	●	●	●	●	●	●	●	●	●	●	●	●	●	●
	20mm Ø Spline															
	30mm Ø Spline															
	3/16 Tapered															
	1/5 Tapered															
	1" Thread															
Air cleaner	Silent		●	●	●	●	●	●	●	●	●				●	●
	Cyclone	●										●	●	●		
	Generator															
Muffler	Standard	●	●	●	●	●	●	●	●			●	●	●	●	●
	Silent									●	●					
Spark arrester		●	●	●	(●)	●	(●)	(●)	(●)	●	●	(●)	(●)	(●)	(●)	(●)
Oil alert		●				●	●	●	●	●	●	●	●	●	●	●
Starter motor							●	●	●						●	●
Reduction																

Specifications		Model	GX340UT1													
		Type	QXE8	QXQ4	QXU	SE	SHQ4	SME0	SXE4	SXE8	SXQ4	VA2	VX16	VX8	VXB7	VXB9
Crankshaft	25mm Ø Straight				●	●	●	●	●	●						
	25.4mm Ø Straight	●	●	●												
	20mm Ø Spline															
	30mm Ø Spline															
	3/16 Tapered										●	●	●	●	●	●
	1/5 Tapered															
	1" Thread															
Air cleaner	Silent	●	●	●	●	●	●	●	●	●	●	●	●	●	●	●
	Cyclone															
	Generator															
Muffler	Standard	●	●	●	●	●	●	●	●	●	●	●	●			●
	Silent													●	●	
Spark arrester		(●)	(●)	(●)	●	(●)	(●)	(●)	(●)	(●)	●	(●)	(●)	●	●	(●)
Oil alert		●	●	●			●	●	●	●	●	●	●	●	●	●
Starter motor		●					●	●	●							●
Reduction																



Specifications		Model	GX340UT1			GX340UT2											
		Type	VXE7	VXE8	VXE9	HA2	HX26	LX2	LXE4	LXQ4	LXU	PKT2	PKX2	QA2	QAE2	QAE6	QAG
Crankshaft	25mm Ø Straight																
	25.4mm Ø Straight												●	●	●	●	
	20mm Ø Spline				●	●											
	30mm Ø Spline						●	●	●	●							
	3/16 Tapered	●	●	●													
	1/5 Tapered																
	1" Thread											●	●				
Air cleaner	Silent	●	●	●	●	●	●	●	●	●	●	●	●	●	●	●	●
	Cyclone																
	Generator																
Muffler	Standard		●		●	●	●	●	●	●	●	●	●	●	●	●	●
	Silent	●		●													
Spark arrester		●	(●)	●	●	(●)	(●)	(●)	(●)	(●)	(●)	(●)	●	●	●	●	●
Oil alert		●	●	●													
Starter motor		●	●	●				●						●	●		
Reduction					●	●	●	●	●	●							

Specifications		Model	GX340UT2														
		Type	QAH2	QAP2	QDW9	QE	QHB4	QH4	QKA4	QMT2	QNE2	QNR2	QWC	QXB7	QXB9	QXC9	QXE4
Crankshaft	25mm Ø Straight																
	25.4mm Ø Straight	●	●	●	●	●	●	●	●	●	●	●	●	●	●	●	●
	20mm Ø Spline																
	30mm Ø Spline																
	3/16 Tapered																
	1/5 Tapered																
	1" Thread																
Air cleaner	Silent	●	●		●	●	●	●	●	●	●	●	●	●			●
	Cyclone			●												●	
	Generator																
Muffler	Standard	●	●	●	●	●	●	●	●	●	●	●				●	●
	Silent												●	●			
Spark arrester		●	●	●	●	●	(●)	●	(●)	(●)	(●)	●	●	●	(●)	(●)	
Oil alert																	
Starter motor										●	●						●
Reduction																	



Specifications		Model	GX340UT2														
		Type	QXE6	QXE8	QXQ4	QXU	QZA2	QZAV	QZN2	QZX4	SE	SE1	SE2	SHQ4	SME0	SMX2	SXE4
Crankshaft	25mm Ø Straight										●	●	●	●	●	●	●
	25.4mm Ø Straight	●	●	●	●	●	●	●	●								
	20mm Ø Spline																
	30mm Ø Spline																
	3/16 Tapered																
	1/5 Tapered																
	1" Thread																
Air cleaner	Silent	●	●	●	●	●	●	●	●	●	●	●	●	●	●	●	●
	Cyclone																
	Generator																
Muffler	Standard	●	●	●	●	●	●	●	●	●	●	●	●	●	●	●	●
	Silent																
Spark arrester		(●)	(●)	(●)	(●)	●	●	(●)	(●)	●	●	●	(●)	(●)	●	(●)	
Oil alert																	
Starter motor		●	●			●	●	●	●			●		●		●	
Reduction																	

Specifications		Model	GX340UT2								
		Type	SXE8	SXQ4	VA2	VX16	VX8	VXB7	VXB9	VXE2	VXE8
Crankshaft	25mm Ø Straight	●	●								
	25.4mm Ø Straight										
	20mm Ø Spline										
	30mm Ø Spline										
	3/16 Tapered			●	●	●	●	●	●	●	●
	1/5 Tapered										
	1" Thread										
Air cleaner	Silent	●	●	●	●	●	●	●	●	●	●
	Cyclone										
	Generator										
Muffler	Standard	●	●	●	●	●			●	●	
	Silent						●	●			●
Spark arrester		(●)	(●)	●	(●)	(●)	●	●	(●)	(●)	●
Oil alert											
Starter motor		●							●	●	●
Reduction											



Specifications		Model	GX340RT1							GX340RT2						
		Type	QNB2	VAD2	VC2	VDE2	VW12	VWC	VWE	VWE2	EDE2	EDN2	EDS6	EDT6	QNB2	VDE2
Crankshaft	25mm Ø Straight															
	25.4mm Ø Straight	●												●		
	20mm Ø Spline															
	30mm Ø Spline															
	3/16 Tapered		●	●	●	●	●	●	●						●	●
	1/5 Tapered									●	●	●	●			
	1" Thread															
Air cleaner	Silent	●	●		●	●			●					●	●	
	Cyclone															
	Generator			●			●	●		●	●	●	●			●
Muffler	Standard	●	●		●	●			●	●	●	●	●	●	●	
	Silent															
Spark arrester		●	●		●	●			●	●	●	●	●	●	●	
Oil alert		●	●	●	●	●	●	●	●							
Starter motor		●						●	●	●		●		●		
Reduction																

Specifications		Model	GX340RT2				GX340UT2X									
		Type	VWE	VWE2	VWS	VWS1	HA2	HX26	LXQ4	PKT2	PKX2	QA2	QAE2	QAE6	QAH2	QAP2
Crankshaft	25mm Ø Straight															
	25.4mm Ø Straight										●	●	●	●	●	
	20mm Ø Spline						●	●								
	30mm Ø Spline								●							
	3/16 Tapered	●	●	●	●											
	1/5 Tapered															
	1" Thread									●	●					
Air cleaner	Silent		●				●	●	●	●	●	●	●	●	●	●
	Cyclone															
	Generator	●		●	●											
Muffler	Standard		●		●		●	●	●	●	●	●	●	●	●	●
	Silent															
Spark arrester			●		●	2000001~	●	(●)	(●)	(●)	(●)	●	●	●	●	●
Oil alert																
Starter motor		●	●									●	●			
Reduction							●	●	●							



Specifications		Model	GX340UT2X													
		Type	QE	QHB4	QKA4	QMT2	QNE2	QNR2	QWC	QXB7	QXE4	QXQ4	SE	SE1	SE2	SME0
Crankshaft	25mm Ø Straight											●	●	●	●	●
	25.4mm Ø Straight	●	●	●	●	●	●	●	●	●	●					
	20mm Ø Spline															
	30mm Ø Spline															
	3/16 Tapered															
	1/5 Tapered															
	1" Thread															
Air cleaner	Silent	●	●	●	●	●	●	●	●	●	●	●	●	●	●	●
	Cyclone															
	Generator															
Muffler	Standard	●	●	●	●	●	●	●		●	●	●	●	●	●	●
	Silent								●							
Spark arrester		●	●	●	(●)	(●)	(●)	●	●	(●)	(●)	●	●	●	(●)	(●)
Oil alert																
Starter motor						●	●			●				●	●	●
Reduction																

Specifications		Model	GX340UT2X		
		Type	SXQ4	VX8	VXE8
Crankshaft	25mm Ø Straight	●			
	25.4mm Ø Straight				
	20mm Ø Spline				
	30mm Ø Spline				
	3/16 Tapered		●	●	
	1/5 Tapered				
	1" Thread				
Air cleaner	Silent	●	●	●	
	Cyclone				
	Generator				
Muffler	Standard	●	●	●	
	Silent				
Spark arrester		(●)	(●)	(●)	
Oil alert					
Starter motor				●	
Reduction					

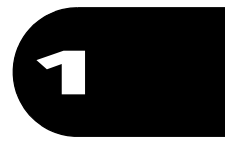

Fuel hose, general purpose hoses and vinyl hose

- The standard part fuel hose, general purpose hose and vinyl hose may be substituted by the coiled bulk part.
- When ordering the standard part fuel hose, general purpose hose and vinyl hose use the bulk part number written in the parts catalog in brackets () underneath the part name.
- When exchanging the hose, cut and use at the specified length as mentioned in the part name.
(For the method of cutting the bulk part, and method of filling out orders etc., please refer to the instructions issued with the bulk part.)

Bulk part number of fuel hose, general purpose hose and vinyl hose.

Example: 9 5 0 0 1 - 7 5 0 0 1 - 5 0 M

Bulk part number:

Refers to the bulk part.

Marking code (fuel hose and general purpose hose)

Change code (Vinyl hose)

Indicates number mark or change sequence, however, the code for the bulk part must be strictly 0 (zero).

Types of code:

- | | | | | | |
|-------------|--|----------------|-------------|--------------|---------------|
| • Fuel hose | 2: Red outside braid
(3 mm inside dia. only) | • General hose | 1: Ash gray | • Vinyl hose | 1: Clear |
| | 5: Black inside braid | | 2: Ash gray | | 2: Black |
| | 3: Red (3 mm inside dia. only) | | 3: Black | | 3: Light red |
| | 4: Ash gray with red stripe
(3 mm inside dia. only) | | 5: Black | | 6: Light red |
| | 6: Black | | | | 7: Pale black |

Lengths:

- 001: 1 m (standard)
003: 3 m
008: 8 m } Application or specification of some parts is not settled.

I.D code: (fuel hose and general purpose hose)

- | | | | | |
|------------|--------------------|--------------------|-----------------------------|-----------------------------|
| 30: 3.0 mm | 50: 5.0 mm | 70: 7.0 mm | 11: 11 mm | 12: 12 (outside dia. 17) mm |
| 35: 3.5 mm | 55: 5.3 mm, 5.5 mm | 75: 7.3 mm, 7.5 mm | 91: 12 (outside dia. 15) mm | 14: 14 mm |
| 45: 4.5 mm | 65: 6.5 mm | 80: 8.0 mm | 92: 12 (outside dia. 16) mm | 17: 17 mm |

ID./OD. code: (vinyl hose)

- | | | | | |
|-------------------------|--------------------------|---------------------------|---------------------------|---------------------------|
| 01: ID. 2.9, OD. 6.8 mm | 12: ID. 5.0, OD. 7.0 mm | 21: ID. 8.0, OD. 9.0 mm | 37: ID. 11.0, OD. 15.0 mm | 50: ID. 16.0, OD. 19.0 mm |
| 03: ID. 3.0, OD. 6.0 mm | 10: ID. 5.0, OD. 8.0 mm | 23: ID. 8.0, OD. 12.0 mm | 38: ID. 12.0, OD. 13.0 mm | 55: ID. 17.5, OD. 20.5 mm |
| 05: ID. 3.5, OD. 6.5 mm | 11: ID. 5.0, OD. 9.0 mm | 25: ID. 9.0, OD. 11.0 mm | 39: ID. 12.0, OD. 14.0 mm | 60: ID. 22.0, OD. 27.0 mm |
| 07: ID. 4.0, OD. 7.0 mm | 14: ID. 6.0, OD. 9.0 mm | 27: ID. 9.0, OD. 13.0 mm | 40: ID. 12.0, OD. 16.0 mm | |
| 08: ID. 4.5, OD. 6.5 mm | 17: ID. 7.0, OD. 9.0 mm | 33: ID. 10.0, OD. 14.0 mm | 43: ID. 13.0, OD. 15.0 mm | |
| 09: ID. 4.5, OD. 8.0 mm | 19: ID. 7.0, OD. 11.0 mm | 36: ID. 11.0, OD. 13.0 mm | 45: ID. 14.0, OD. 18.0 mm | |

Hose type:

- 1: Fuel hose
3: Vinyl hose
5: General hose

⊙ **CAUTION: It is DANGEROUS to confuse the fuel hose with the general purpose hose or vinyl hose.**

Never use a general purpose hose or vinyl hose in place of a fuel hose or vice versa. Always use the correct bulk part in the parts catalogue, according to the service manual or the instructions issued with the bulk part.

ENGINE GROUP

E-2

CYLINDER HEAD

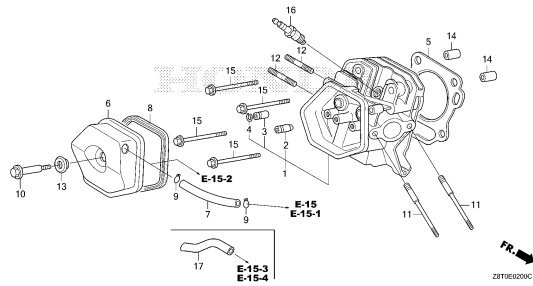

E-3

CYLINDER BARREL

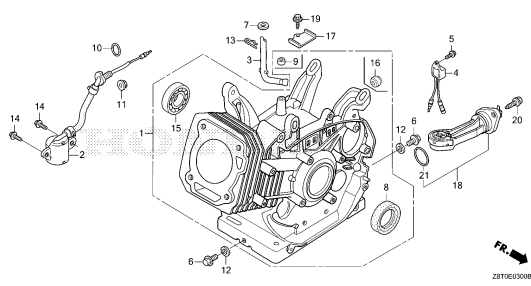

E-6

CRANKCASE COVER(1)

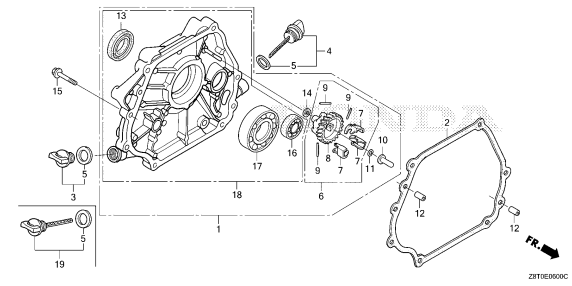

E-6-1

CRANKCASE COVER(2)

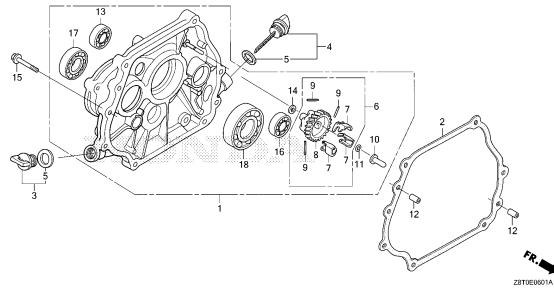

E-7

CRANKSHAFT

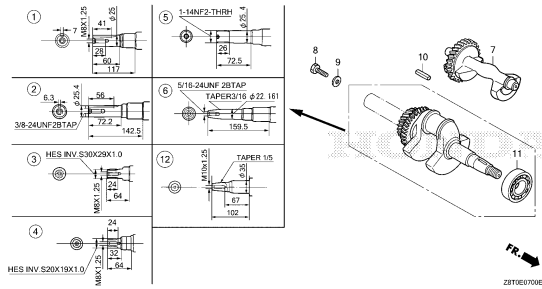

E-8

PISTON

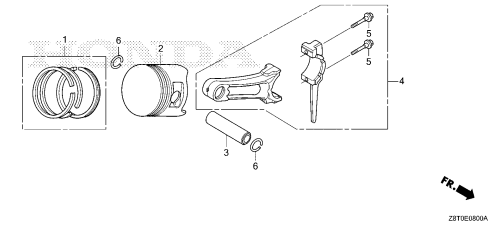

E-9

CAMSHAFT

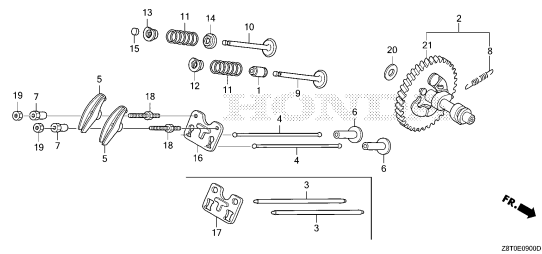

E-11

RECOIL STARTER(1)

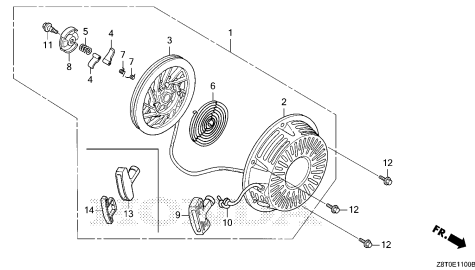

E-11-1

RECOIL STARTER(2)

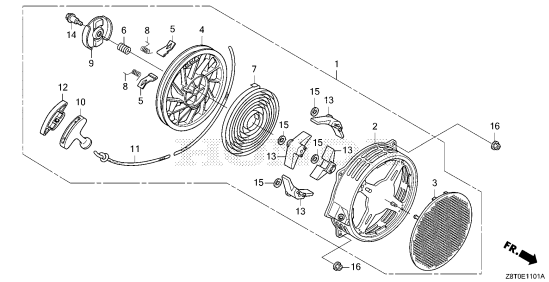

2

ENGINE GROUP

E-12

FAN COVER(1)

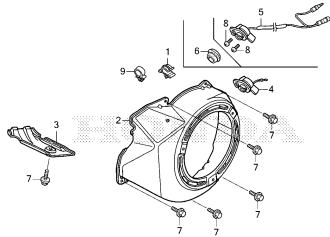

ZHT0E1200C

E-12-1

FAN COVER(2)

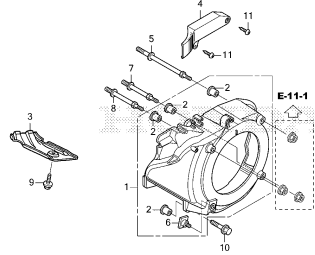

ZHT0E1201A

E-14

CARBURETOR(1)

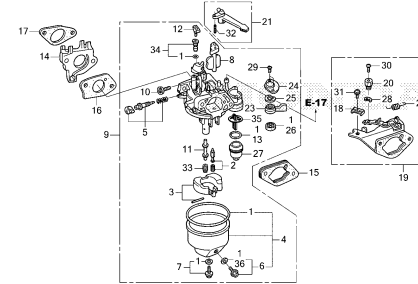

ZHT0E1400C

E-14-1

CARBURETOR(2)

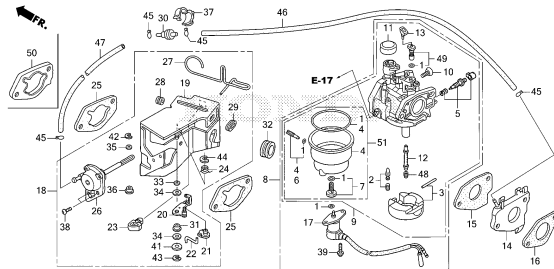

ZHT0E1401C

E-14-2

CARBURETOR(3)

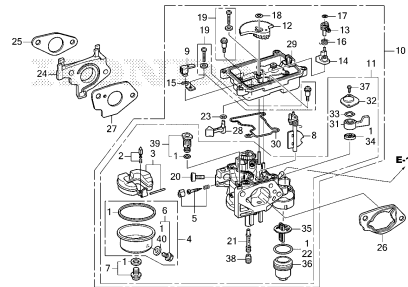

ZHT0E1402B

E-15

AIR CLEANER(1)

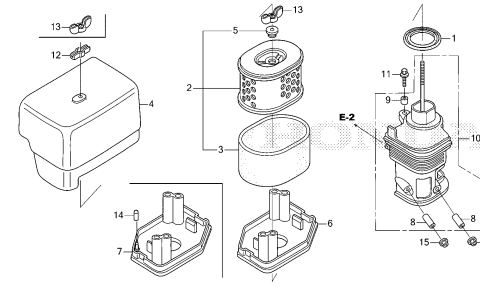

ZHT0E1500A

E-15-1

AIR CLEANER(2)

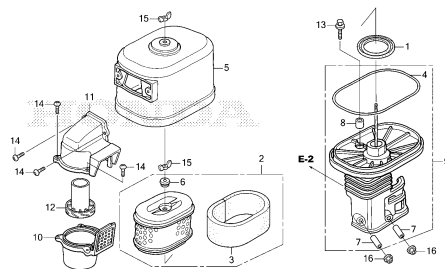

ZHT0E1501A

E-15-2

AIR CLEANER(3)

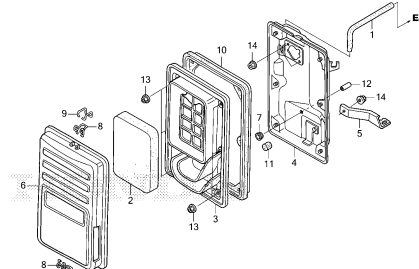

ZHT0E1502B

E-15-3

AIR CLEANER(4)

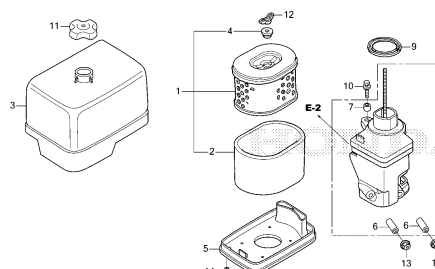

ZHT0E1503B

ENGINE GROUP

E-15-4

AIR CLEANER(5)

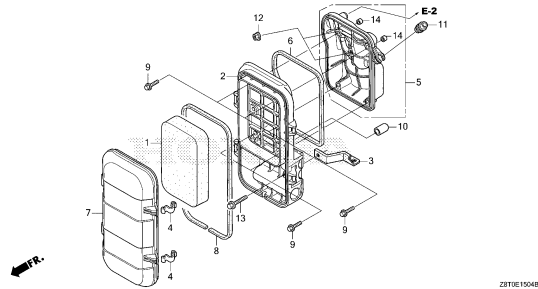

E-16

MUFFLER(1)

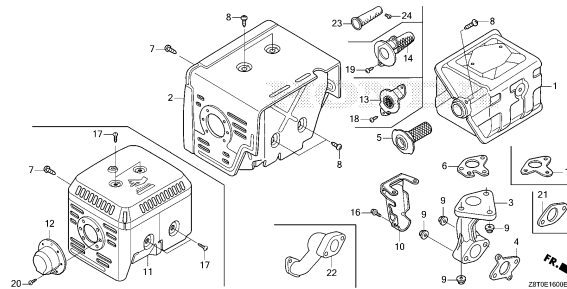

E-16-1

MUFFLER(2)

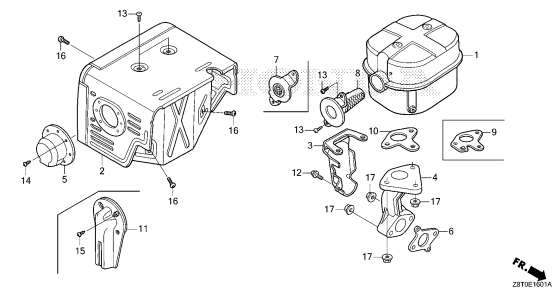

E-16-2

MUFFLER(3)

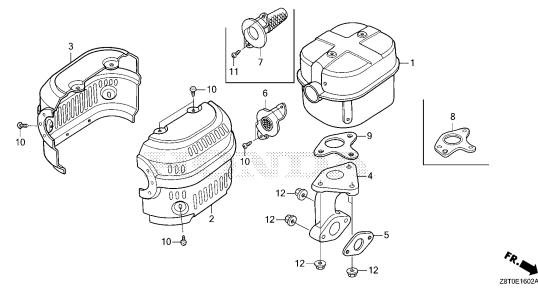

E-17

FUEL TANK

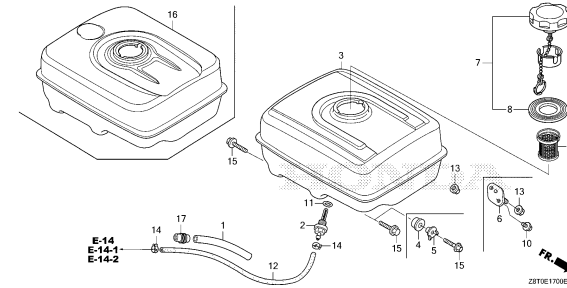

E-19

FLYWHEEL

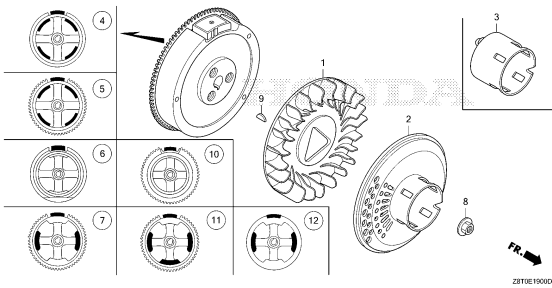

E-20

IGNITION COIL

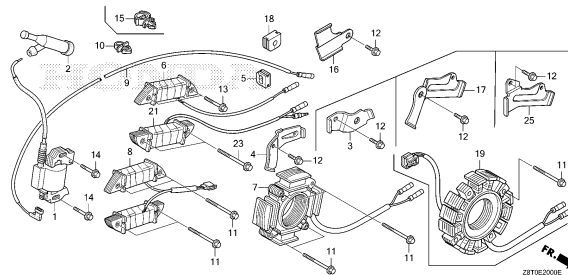

E-20-10

ELECTRONIC CONTROL UNIT

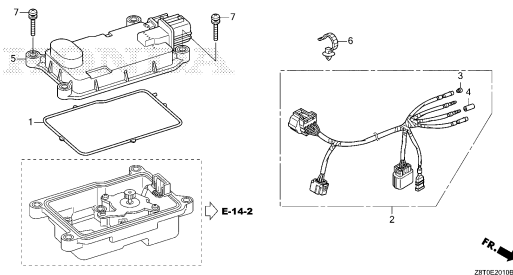

E-21

STARTER MOTOR(1)

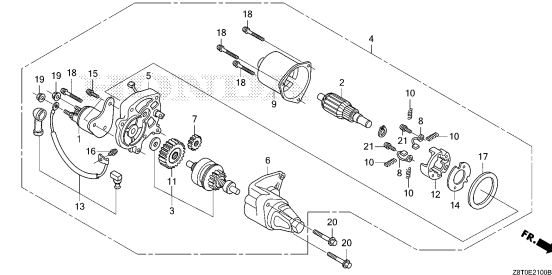

2

ENGINE GROUP

E-21-1

STARTER MOTOR(2)

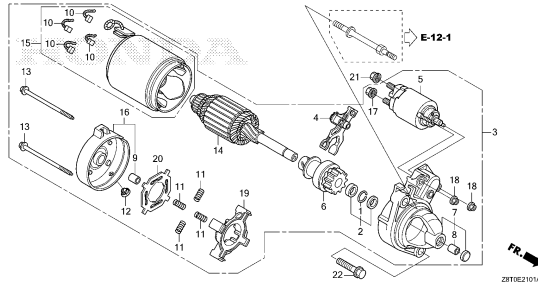

E-22

CONTROL

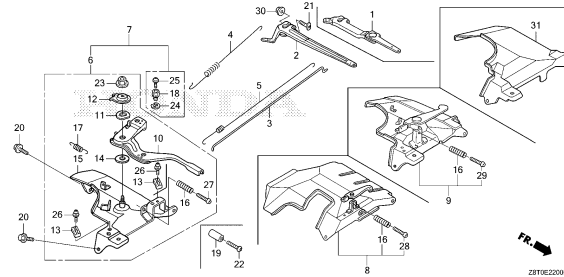

E-22-20

AUTO THROTTLE

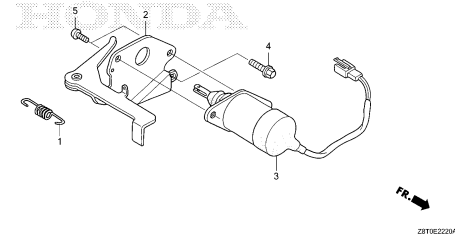

E-23

CONTROL BOX(1)

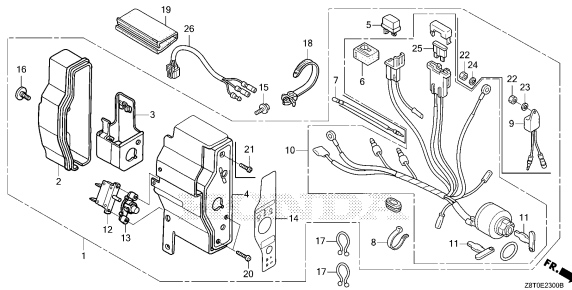

E-23-1

CONTROL BOX(2)

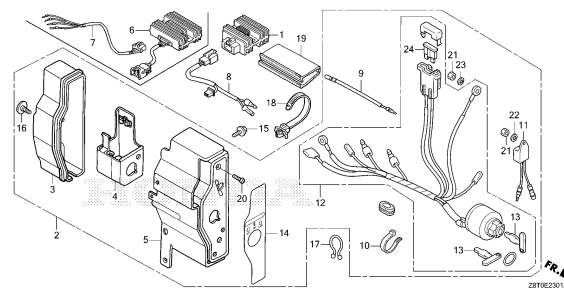

E-23-2

CONTROL BOX(3)

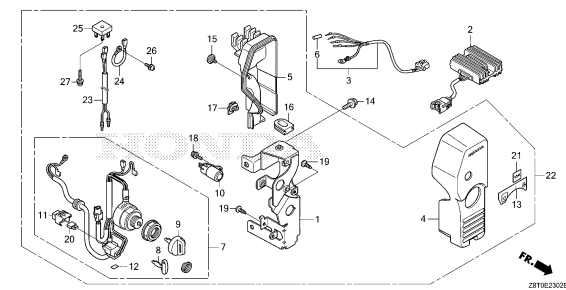

E-23-3

CONTROL BOX(4)

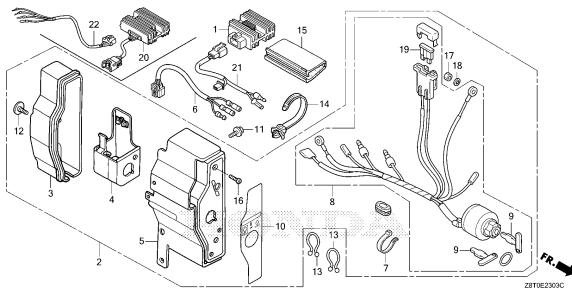

E-26

REDUCTION(1)

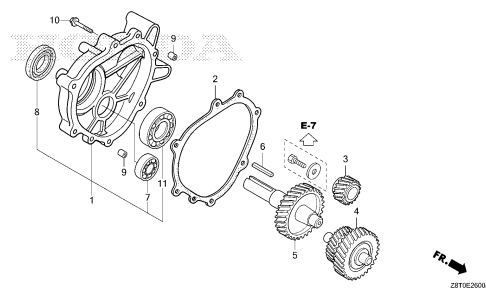

E-26-1

REDUCTION(2)

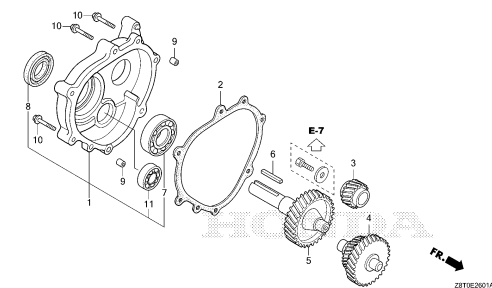

2

ENGINE GROUP

E-28

LABEL/TOOL

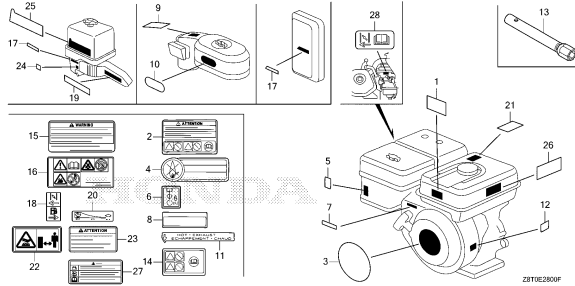

ZHT0E2800F

E-40

OTHER PARTS(COMBINATION SWITCH)

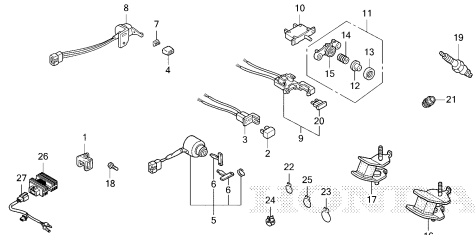

ZHT0E4000C

E-40-1

OTHER PARTS(FUEL COCK)

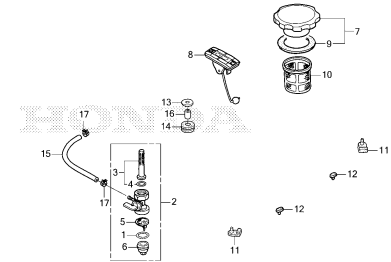

ZHT0E4001A

E-40-2

OTHER PARTS(AIR CLEANER)

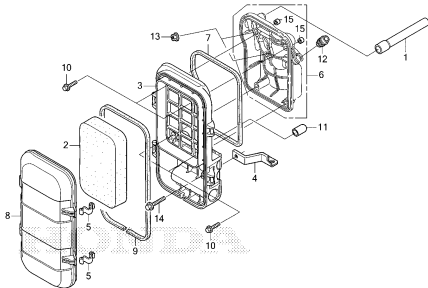

ZHT0E4002B

E-40-3

OTHER PARTS(MUFFLER)

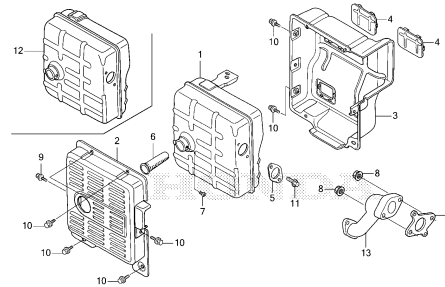

ZHT0E4003B

EOP-1

GASKET KIT

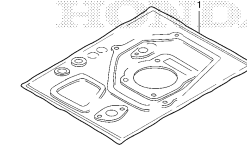

ZHT0E0100

EOP-2

MUFFLER COVER

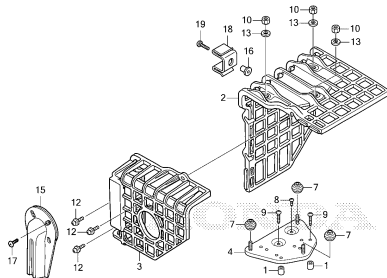

ZHT0E0200C

2

E-2

CYLINDER HEAD

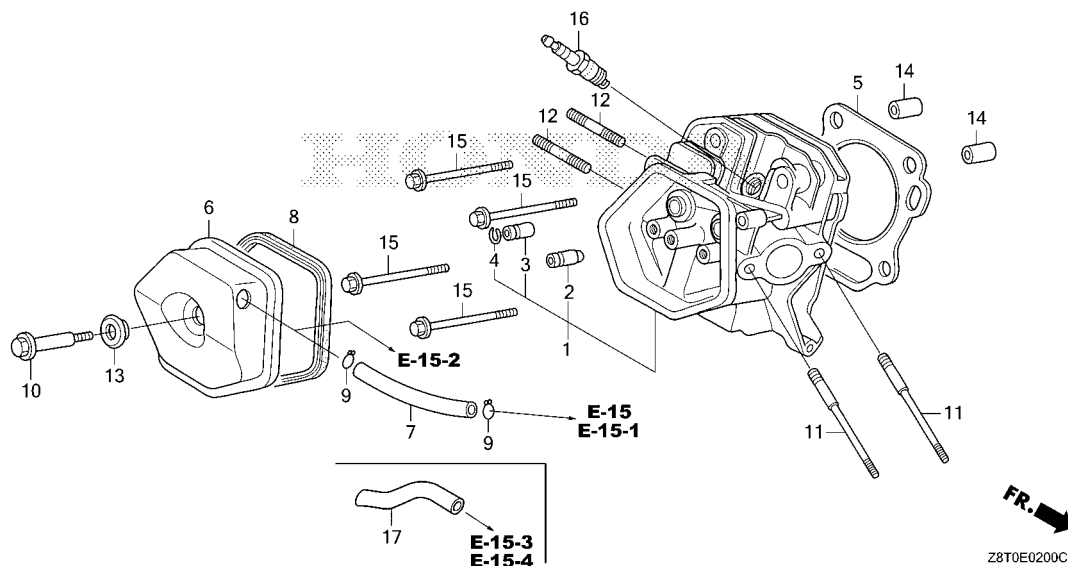

Ref. L.O.N. (Relative ref. Number) F.R.T.
No. Description

Ref. No.	Part No.	Description	Reqd. QTY					Serial No.	Parts catalogue code
			GX 340 UT1	GX 340 UT2	GX 340 RT1	GX 340 RT2	GX 340 UT2X		
1	12200-Z1C-406 12210-Z5T-416	HEAD COMP., CYLINDER.....	1	-	1	-	-	EDE2/A, EDN2/A, EDS6/A, EDT6/A, HA2/A, HX26/A, LXQ4/A, PKT2/A, PKX2/A, QA2/A, QAE2/A, QAE6/A, QAH2/A, QAP2/A, QE/A, QHB4/A, QKA4/A, QMT2/A, QNE2/A, QNR2/A, QWC, QWC/A, QXB7/A, QXE4/A, QXQ4/A, QXU/A, SE/A, SE1, SE2, SHQ4/A, SME0/A, SXE4/A, SXQ4/A, VWC/A, VWE/A, VWE2/A, VWS1, VWS1/A, VX16/A, VX8/A, VXE2/A, VXE8/A	
	12210-Z5T-406	-	1	-	1	-	1045989 EDE2, EDN2, EDS6, EDT6, HA2, HX26, LX2, LXE4, LXQ4, LXU, PKT2, PKX2, QA2, QAE2, QAE6, QAG, QAH2, QAP2, QDW9, QE, QHB4, QHQ4, QKA4, QMT2, QNB2, QNE2, QNR2, QXB7, QXB9, QXC9, QXE4, QXE6, QXE8, QXQ4, QXU, QZA2, QZAV, QZN2, QZX4, SE, SHQ4, SME0, SMX2, SXE4, SXE8, SXQ4, VA2, VDE2, VWC, VWE, VWE2, VWS, VX16, VX8, VXB7, VXB9, VXE2, VXE8, VXE9	
	12210-Z5T-416	-	1	-	1	-	1045990 EDE2, EDN2, EDS6, EDT6, HA2, HX26, LX2, LXE4, LXQ4, LXU, PKT2, PKX2, QA2, QAE2, QAE6, QAG, QAH2, QAP2, QDW9, QE, QHB4, QHQ4, QKA4, QMT2, QNB2, QNE2, QNR2, QXB7, QXB9, QXC9, QXE4, QXE6, QXE8, QXQ4, QXU, QZA2, QZAV, QZN2, QZX4, SE, SHQ4, SME0, SMX2, SXE4, SXE8, SXQ4, VA2, VDE2, VWC, VWE, VWE2, VWS, VX16, VX8, VXB7, VXB9, VXE2, VXE8, VXE9	
2	12204-ZE2-306	GUIDE, IN. VALVE(O.S.).....	-	-	-	-	1	LX2, LXE4, LXU, QAG, QDW9, QHQ4, QXB9, QXE6, QXE8, QXU, QXU/A, QZA2, QZAV, QZN2, QZX4, SHQ4, SHQ4/A, SMX2, SXE8, VA2, VX16, VX16/A, VXB7, VXB9, VXE2, VXE2/A, VXE9	
3	12205-ZE2-305	GUIDE, EX. VALVE(O.S.).....	-	-	-	1	-	QNB2, VDE2, VWS	
			-	1	-	-	-	LX2, LXE4, LXU, QAG, QDW9, QHQ4, QXB9, QXE6, QXE8, QXU, QXU/A, QZA2, QZAV, QZN2, QZX4, SHQ4, SHQ4/A, SMX2, SXE8, VA2, VX16, VX16/A, VXB7, VXB9, VXE2, VXE2/A, VXE9	
			-	-	-	1	-	QNB2, VDE2, VWS	

E-2

CYLINDER HEAD

Ref. No.	Part No.	Description	Reqd. QTY					Serial No.	Parts catalogue code
			GX 340 UT1	GX 340 UT2	GX 340 RT1	GX 340 RT2	GX 340 UT2X		
4	12216-ZE2-300	CLIP, VALVE GUIDE	1	-	-	-	-	1030809 -----	EDE2, EDE2/A, EDN2, EDN2/A, EDS6, EDS6/A, EDT6, EDT6/A, HA2, HA2/A, HX26, HX26/A, LX2, LXE4, LXQ4, LXQ4/A, LXU, PKT2, PKT2/A, PKX2, PKX2/A, QA2, QA2/A, QAE2, QAE2/A, QAE6, QAE6/A, QAG, QAH2, QAH2/A, QAP2, QAP2/A, QDW9, QE, QE/A, QHB4, QHB4/A, QHQ4, QKA4, QKA4/A, QMT2, QMT2/A, QNB2, QNE2, QNE2/A, QNR2, QNR2/A, QWC, QWC/A, QXB7, QXB7/A, QXB9, QXC9, QXE4, QXE4/A, QXE6, QXE8, QXQ4, QXQ4/A, QXU, QXU/A, QZA2, QZAV, QZX4, SE, SE/A, SE1, SE2, SHQ4, SHQ4/A, SME0, SME0/A, SMX2, SXE4, SXE4/A, SXE8, SXQ4, SXQ4/A, VA2, VDE2, VWC, VWC/A, VWE, VWE/A, VWE2, VWE2/A, VWS, VWS1, VWS1/A, VX16, VX16/A, VX8, VX8/A, VXB7, VXB9, VXE2, VXE2/A, VXE8, VXE8/A, VXE9
5	12251-Z8T-801 12251-Z5T-003	GASKET, CYLINDER HEAD	1	-	1	-	-		
		GASKET, CYLINDER HEAD (NIPPON LEAKLESS)	-	1	-	1	1		
6	12310-ZE2-020	COVER COMP., HEAD	1	-	1	-	-	-----	HA2, HX26, LX2, LXE4, LXE8, LXQ4, LXU, PKT2, QA2, QA26, QAE2, QAE6, QAG, QAH2, QAP2, QE, QHB4, QHQ4, QKA4, QNB2, QNE2, QNR2, QNR6, QXB7, QXB9, QXE4, QXE6, QXE8, QXQ4, QXU, SE, SHQ4, SME0, SXE4, SXE8, SXQ4, VA2, VAD2, VC2, VDE2, VW12, VWC, VWE, VWE2, VX16, VX8, VXB7, VXB9, VXE2, VXE7, VXE8, VXE9
	12310-ZE3-791	COVER COMP., HEAD (BREATHER TUBE JOINT)	1	-	-	-	-	-----	QDW9, QXC4, QXC6, QXC9
	12310-Z5T-000	COVER, CYLINDER HEAD	-	1	-	1	-	1028595 -----	HA2, HX26, LX2, LXE4, LXQ4, LXU, PKT2, QA2, QAE2, QAE6, QAG, QAH2, QAP2, QE, QHB4, QHQ4, QKA4, QNB2, QNE2, QNR2, QXB7, QXB9, QXE4, QXE6, QXE8, QXQ4, QXU, SE, SHQ4, SME0, SXE4, SXE8, SXQ4, VA2, VDE2, VWE2, VX16, VX8, VXB7, VXB9, VXE2, VXE8, VXE9
	12310-ZE2-020	COVER COMP., HEAD	-	1	-	1	-	1028596 -----	HA2, HX26, LX2, LXE4, LXQ4, LXU, PKT2, QA2, QAE2, QAE6, QAG, QAH2, QAP2, QE, QHB4, QHQ4, QKA4, QNB2, QNE2, QNR2, QXB7, QXB9, QXE4, QXE6, QXE8, QXQ4, QXU, SE, SHQ4, SME0, SXE4, SXE8, SXQ4, VA2, VDE2, VWE2, VX16, VX8, VXB7, VXB9, VXE2, VXE8, VXE9
			-	1	-	-	-	-----	HA2/A, HX26/A, LXQ4/A, PKT2/A, PKX2, PKX2/A, QA2/A, QAE2/A, QAE6/A, QAH2/A, QAP2/A, QE/A, QHB4/A, QKA4/A, QMT2, QMT2/A, QNE2/A, QNR2/A, QWC, QWC/A, QXB7/A, QXE4/A, QXQ4/A, QXU/A, QZA2, QZAV, QZN2, QZX4, SE/A, SE1, SE2, SHQ4/A, SME0/A, SMX2, SXE4/A, SXQ4/A, VX16/A, VX8/A, VXE2/A, VXE8/A
	12310-Z5T-800 12310-ZE3-791	COVER COMP., CYLINDER HEAD ... COVER COMP., HEAD (BREATHER TUBE JOINT)	-	1	-	-	-	1057637 -----	QDW9, QXC9
	12310-ZE2-020	COVER COMP., HEAD	-	-	-	1	-	-----	EDE2, EDE2/A, EDN2, EDN2/A, EDS6, EDS6/A, EDT6, EDT6/A, VWC, VWC/A, VWE, VWE/A, VWE2/A, VWS, VWS1, VWS1/A
			-	-	-	-	1		
7	12315-ZE3-840 95005-11105-30	TUBE, BREATHER	1	1	-	-	-	-----	QDW9, QXC4, QXC6, QXC9
		TUBE, 11X105(95005-11001-30M)	1	-	1	-	-	-----	HA2, HX26, LX2, LXE4, LXE8, LXQ4, LXU, PKT2, QA2, QA26, QAE2, QAE6, QAG, QAH2, QAP2, QE, QHB4, QHQ4, QKA4, QNB2, QNE2, QNR2, QNR6, QXB7, QXB9, QXE4, QXE6, QXE8, QXQ4, QXU, SE, SHQ4, SME0, SXE4, SXE8, SXQ4, VA2, VAD2, VDE2, VW12, VWE2, VX16, VX8, VXB7, VXB9, VXE2, VXE7, VXE8, VXE9
8	12391-ZE2-020	PACKING, HEAD COVER	1	1	1	1	1		
9	17316-611-000	CLIP, BREATHER TUBE	2	2	-	-	-	-----	QDW9, QXC4, QXC6, QXC9
10	90014-ZE2-000 90014-Z5T-000	BOLT, HEAD COVER	1	-	1	-	-		
		-	1	-	1	1		



E-2

CYLINDER HEAD

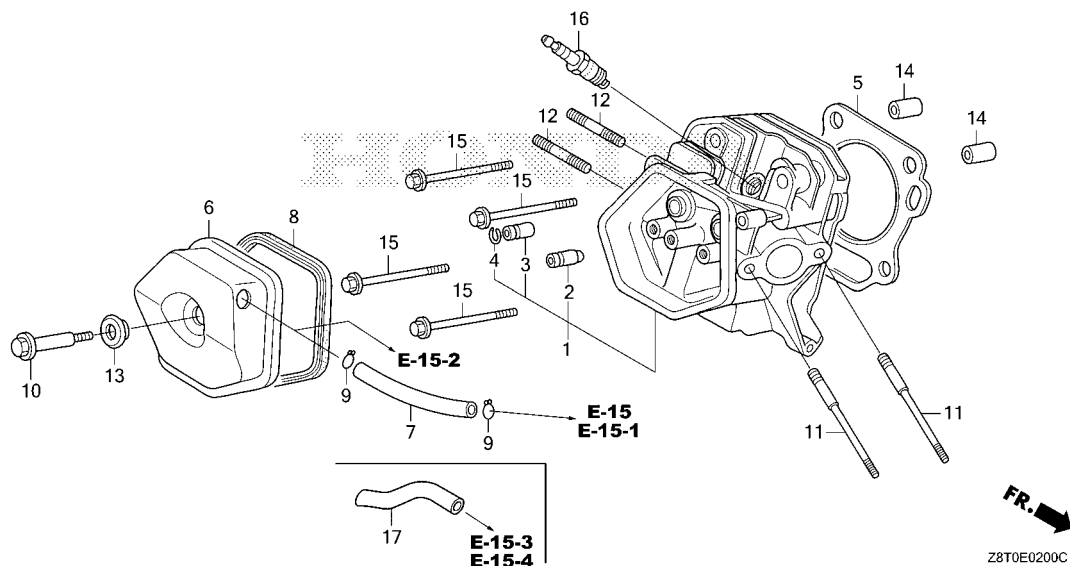

Ref. No.	Part No.	Description	Reqd. QTY					Serial No.	Parts catalogue code
			GX 340 UT1	GX 340 UT2	GX 340 RT1	GX 340 RT2	GX 340 UT2X		
11	90042-ZE8-000	BOLT, STUD, 8X131.5	2	2	2	2	2	HA2, HA2/A, HX26, HX26/A, LX2, LXE4, LXE8, LXQ4, LXQ4/A, LXU, PKT2, PKT2/A, PKX2, PKX2/A, QA2, QA2/A, QA26, QAE2, QAE2/A, QAE6, QAE6/A, QAG, QAH2, QAH2/A, QAP2, QAP2/A, QDW9, QE, QE/A, QHB4, QHB4/A, QHQ4, QKA4, QKA4/A, QMT2, QMT2/A, QNB2, QNE2, QNE2/A, QNR2, QNR2/A, QNR6, QWC, QWC/A, QXB7, QXB7/A, QXB9, QXC4, QXC6, QXC9, QXE4, QXE4/A, QXE6, QXE8, QXQ4, QXQ4/A, QXU, QXU/A, QZA2, QZAV, QZN2, QZX4, SE, SE/A, SE1, SE2, SHQ4, SHQ4/A, SME0, SME0/A, SMX2, SXE4, SXE4/A, SXE8, SXQ4, SXQ4/A, VA2, VAD2, VDE2, VW12, VWE2, VWE2/A, VX16, VX16/A, VX8, VX8/A, VXB7, VXB9, VXE2, VXE2/A, VXE7, VXE8, VXE8/A, VXE9	
	90042-ZE3-700	BOLT, STUD, 8X106	-	-	2	-	-	VC2, VWC, VWE	
	90042-ZK6-D70	BOLT, STUD, 8X115	-	-	-	2	-	EDE2, EDE2/A, EDN2, EDN2/A, EDS6, EDS6/A, EDT6, EDT6/A, VWC, VWC/A, VWE, VWE/A, VWS, VWS1, VWS1/A	
12	92900-08032-0E	BOLT, STUD, 8X32	2	2	2	-	2	HA2, HA2/A, HX26, HX26/A, LX2, LXE4, LXE8, LXQ4, LXQ4/A, LXU, PKT2, PKT2/A, PKX2, PKX2/A, QA2, QA2/A, QA26, QAE2, QAE2/A, QAE6, QAE6/A, QAG, QAH2, QAH2/A, QAP2, QAP2/A, QDW9, QE, QE/A, QHB4, QHB4/A, QHQ4, QKA4, QKA4/A, QMT2, QMT2/A, QNB2, QNE2, QNE2/A, QNR2, QNR2/A, QNR6, QWC, QWC/A, QXB7, QXB7/A, QXB9, QXC4, QXC6, QXC9, QXE4, QXE4/A, QXE6, QXE8, QXQ4, QXQ4/A, QXU, QXU/A, QZA2, QZAV, QZN2, QZX4, SE, SE/A, SE1, SE2, SHQ4, SHQ4/A, SME0, SME0/A, SMX2, SXE4, SXE4/A, SXE8, SXQ4, SXQ4/A, VA2, VAD2, VC2, VDE2, VW12, VWE2, VX16, VX16/A, VX8, VX8/A, VXB7, VXB9, VXE2, VXE2/A, VXE7, VXE8, VXE8/A, VXE9	
	90047-ZE3-791	BOLT, STUD, 8X25	-	-	2	2	-	VWC, VWC/A, VWE, VWE/A, VWE2/A	
	92900-08032-0E	BOLT, STUD, 8X32	-	-	-	2	-	EDE2, EDE2/A, EDN2, EDN2/A, EDS6, EDS6/A, EDT6, EDT6/A, QNB2, VDE2, VWS1, VWS1/A	
	90018-ZK6-P10	BOLT, STUD, 8X22	-	-	-	2	-	VWS	
	92900-08032-0E	BOLT, STUD, 8X32	-	-	-	2	-	VWE2	
	90047-ZE3-791	BOLT, STUD, 8X25	-	-	-	2	1104462	VWE2	
13	90441-ZE2-010	WASHER COMP., HEAD COVER	1	1	1	1	1		



E-2

CYLINDER HEAD

Ref. No.	Part No.	Description	Reqd. QTY					Serial No.	Parts catalogue code
			GX 340 UT1	GX 340 UT2	GX 340 RT1	GX 340 RT2	GX 340 UT2X		
14	94301-12200	DOWEL PIN, 12X20.....	2	2	2	2	2		
15	95701-10080-00	BOLT, FLANGE, 10X80.....	4	4	4	4	4		
16	98079-56876	PLUG, SPARK(BPR6ES)(NGK).....	1	1	1	1	1	----- HA2, HA2/A, HX26, HX26/A, LX2, LXE4, LXE8, LXQ4, LXQ4/A, LXU, PKT2, PKT2/A, PKX2, PKX2/A, QA2, QA2/A, QA26, QAE2, QAE2/A, QAE6, QAE6/A, QAG, QAH2, QAH2/A, QAP2, QAP2/A, QDW9, QE, QE/A, QHB4, QHB4/A, QHQ4, QKA4, QKA4/A, QMT2, QMT2/A, QNB2, QNE2, QNE2/A, QNR2, QNR2/A, QNR6, QWC, QWC/A, QXB7, QXB7/A, QXB9, QXC4, QXC6, QXC9, QXE4, QXE4/A, QXE6, QXE8, QXQ4, QXQ4/A, QXU, QXU/A, QZA2, QZAV, QZN2, QZX4, SE, SE/A, SE1, SE2, SHQ4, SHQ4/A, SME0, SME0/A, SMX2, SXE4, SXE4/A, SXE8, SXQ4, SXQ4/A, VA2, VAD2, VDE2, VW12, VWE2, VWE2/A, VX16, VX16/A, VX8, VX8/A, VXB7, VXB9, VXE2, VXE2/A, VXE7, VXE8, VXE8/A, VXE9	
	98079-55855	PLUG, SPARK(W16EPR-U)(DENSO)·	(1)	(1)	(1)	(1)	(1)	----- HX26, HX26/A, LX2, LXE4, LXE8, LXQ4, LXQ4/A, LXU, PKT2, PKT2/A, PKX2, PKX2/A, QA2, QA2/A, QA26, QAE2, QAE2/A, QAE6, QAE6/A, QAG, QAH2, QAH2/A, QAP2, QAP2/A, QDW9, QE, QE/A, QHB4, QHB4/A, QHQ4, QKA4, QKA4/A, QMT2, QMT2/A, QNB2, QNE2, QNE2/A, QNR2, QNR2/A, QNR6, QWC, QWC/A, QXB7, QXB7/A, QXB9, QXC4, QXC6, QXC9, QXE4, QXE4/A, QXE6, QXE8, QXQ4, QXQ4/A, QXU, QXU/A, QZA2, QZAV, QZN2, QZX4, SE, SE/A, SE1, SE2, SHQ4, SHQ4/A, SME0, SME0/A, SMX2, SXE4, SXE4/A, SXE8, SXQ4, SXQ4/A, VA2, VAD2, VDE2, VW12, VWE2, VWE2/A, VX16, VX16/A, VX8, VX8/A, VXB7, VXB9, VXE2, VXE2/A, VXE7, VXE8, VXE8/A, VXE9	
	98079-56855	PLUG, SPARK(W20EPR-U)(DENSO)·	1	1	1	1	-	----- HA2, HX26, LX2, LXE4, LXE8, LXQ4, LXU, PKT2, PKX2, PKX2/A, QA2, QA26, QAE2, QAE6, QAG, QAH2, QAP2, QDW9, QE, QHB4, QHQ4, QKA4, QMT2, QMT2/A, QNB2, QNE2, QNR2, QNR6, QWC, QXB7, QXB9, QXC4, QXC6, QXC9, QXE4, QXE6, QXE8, QXQ4, QXU, QZA2, QZAV, QZN2, QZX4, SE, SHQ4, SME0, SMX2, SXE4, SXE8, SXQ4, VA2, VAD2, VDE2, VW12, VWE2, VWE2/A, VX16, VX8, VXB7, VXB9, VXE2, VXE7, VXE8, VXE9	
	98079-55846	PLUG, SPARK(BPR5ES)(NGK).....	(1)	-	(1)	(1)	-	----- HA2, HX26, LX2, LXE4, LXE8, LXQ4, LXU, PKT2, QA2, QA26, QAE2, QAE6, QAG, QAH2, QAP2, QDW9, QE, QHB4, QHQ4, QKA4, QNB2, QNE2, QNR2, QNR6, QXB7, QXB9, QXC4, QXC6, QXC9, QXE4, QXE6, QXE8, QXQ4, QXU, SE, SHQ4, SME0, SXE4, SXE8, SXQ4, VA2, VAD2, VDE2, VW12, VWE2, VWE2/A, VX16, VX8, VXB7, VXB9, VXE2, VXE7, VXE8, VXE9	
	98079-55876	-	(1)	-	(1)	(1)	----- HA2, HA2/A, HX26, HX26/A, LX2, LXE4, LXQ4, LXQ4/A, LXU, PKT2, PKT2/A, PKX2, PKX2/A, QA2, QA2/A, QAE2, QAE2/A, QAE6, QAE6/A, QAG, QAH2, QAH2/A, QAP2, QAP2/A, QDW9, QE, QE/A, QHB4, QHB4/A, QHQ4, QKA4, QKA4/A, QMT2, QMT2/A, QNB2, QNE2, QNE2/A, QNR2, QNR2/A, QWC, QWC/A, QXB7, QXB7/A, QXB9, QXC4, QXC6, QXC9, QXE4, QXE4/A, QXE6, QXE8, QXQ4, QXQ4/A, QXU, QXU/A, QZA2, QZAV, QZN2, QZX4, SE, SE/A, SE1, SE2, SHQ4, SHQ4/A, SME0, SME0/A, SMX2, SXE4, SXE4/A, SXE8, SXQ4, SXQ4/A, VA2, VDE2, VWE2, VWE2/A, VX16, VX16/A, VX8, VX8/A, VXB7, VXB9, VXE2, VXE2/A, VXE8, VXE8/A, VXE9	
	98079-55846	-	(1)	-	-	-	----- HA2, HA2/A, HX26, HX26/A, LX2, LXE4, LXQ4, LXQ4/A, LXU, PKT2, PKT2/A, QA2, QA2/A, QAE2, QAE2/A, QAE6, QAE6/A, QAG, QAH2, QAH2/A, QAP2, QAP2/A, QE, QE/A, QHB4, QHB4/A, QHQ4, QKA4/A, QNE2, QNE2/A, QNR2, QNR2/A, QWC, QWC/A, QXB7, QXB7/A, QXB9, QXE4, QXE4/A, QXE6, QXE8, QXQ4, QXQ4/A, QXU, QXU/A, QZN2, SE, SE/A, SE1, SE2, SHQ4, SHQ4/A, SME0, SME0/A, SXE4, SXE4/A, SXE8, SXQ4, SXQ4/A, VA2, VX16, VX16/A, VX8, VX8/A, VXB7, VXB9, VXE2, VXE2/A, VXE8, VXE8/A, VXE9	
	98079-55855	PLUG, SPARK(W16EPR-U)(DENSO)·	-	-	1	1	-	----- EDE2, EDE2/A, EDN2, EDN2/A, EDS6, EDS6/A, EDT6, EDT6/A, VC2, VWC, VWC/A, VWE, VWE/A, VWS	
	98079-55846	PLUG, SPARK(BPR5ES)(NGK).....	-	-	1	-	-	----- 1000281 VC2, VWC, VWE	
	98079-55876	-	-	1	-	-	----- 1000282 VC2, VWC, VWE	
			-	-	-	1	-	----- EDE2, EDE2/A, EDN2, EDN2/A, EDS6, EDS6/A, EDT6, EDT6/A, VWC, VWC/A, VWE, VWE/A, VWS, VWS1, VWS1/A	



E-2

CYLINDER HEAD

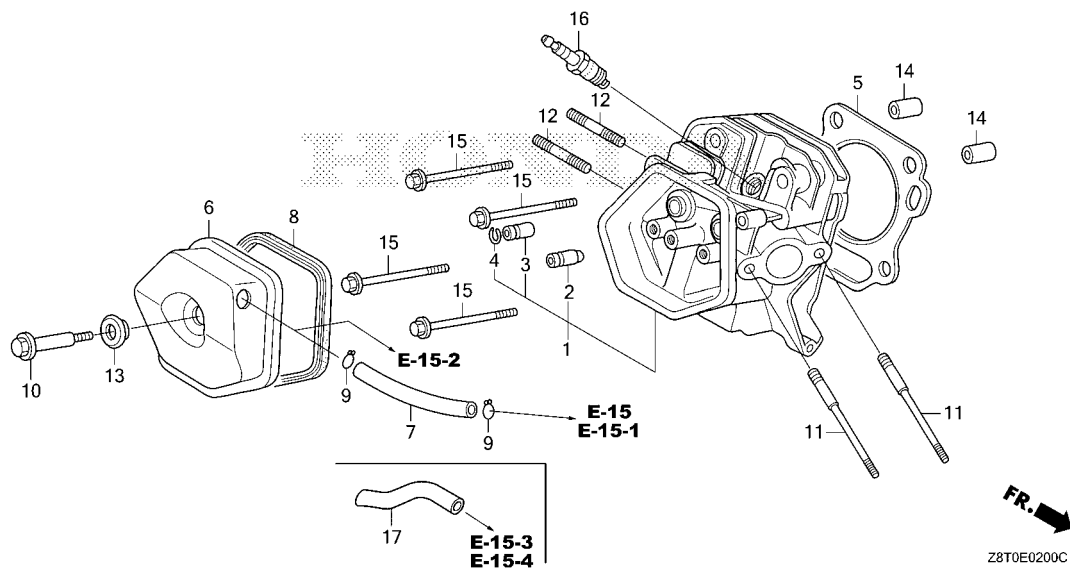

Ref. No.	Part No.	Description	Reqd. QTY					Serial No.	Parts catalogue code
			GX 340 UT1	GX 340 UT2	GX 340 RT1	GX 340 RT2	GX 340 UT2X		
16)	98079-55846	PLUG, SPARK(BPR5E5)(NGK).....	-	-	-	-	(1)	HA2, HX26, LXQ4, PKT2, QA2, QAE2, QAE6, QAH2, QAP2, QE, QHB4, QKA4, QNE2, QNR2, QWC, QXB7, QXE4, QXQ4, SE, SE1, SE2, SME0, SXE4, SXQ4, VX8, VXE8	
	98079-56855	PLUG, SPARK(W20EPR-U)(DENSO).....	-	-	-	-	1	PKX2, QMT2	
17	12357-Z5T-020	TUBE, BREATHER.....	-	1	-	1	-	HA2/A, HX26/A, LXQ4/A, PKT2/A, PKX2, PKX2/A, QA2/A, QAE2/A, QAE6/A, QAH2/A, QAP2/A, QE/A, QHB4/A, QKA4/A, QMT2, QMT2/A, QNE2/A, QNR2/A, QWC, QWC/A, QXB7/A, QXE4/A, QXQ4/A, QXU/A, SE/A, SE1, SE2, SHQ4/A, SME0/A, SMX2, SXE4/A, SXQ4/A, VWE2/A, VX16/A, VX8/A, VXE2/A, VXE8/A	
	12357-Z5T-010	-	1	-	1	-	1028595 HA2, HX26, LX2, LXE4, LXQ4, LXU, PKT2, QA2, QAE2, QAE6, QAG, QAH2, QAP2, QE, QHB4, QHQ4, QKA4, QNB2, QNE2, QNR2, QXB7, QXB9, QXE4, QXE6, QXE8, QXQ4, QXU, QZA2, QZAV, QZN2, QZX4, SE, SHQ4, SME0, SXE4, SXE8, SXQ4, VA2, VDE2, VWE2, VX16, VX8, VXB7, VXB9, VXE2, VXE8, VXE9	
	12357-Z5T-020	-	1	-	1	-	1028596 HA2, HX26, LX2, LXE4, LXQ4, LXU, PKT2, QA2, QAE2, QAE6, QAG, QAH2, QAP2, QE, QHB4, QHQ4, QKA4, QNB2, QNE2, QNR2, QXB7, QXB9, QXE4, QXE6, QXE8, QXQ4, QXU, QZA2, QZAV, QZN2, QZX4, SE, SHQ4, SME0, SXE4, SXE8, SXQ4, VA2, VDE2, VWE2, VX16, VX8, VXB7, VXB9, VXE2, VXE8, VXE9	
	15721-Z23-H60	-	-	-	1	-	VWC, VWC/A, VWE, VWE/A, VWS1, VWS1/A	
	12357-Z5T-020	-	-	-	1	-		

E-3

CYLINDER BARREL

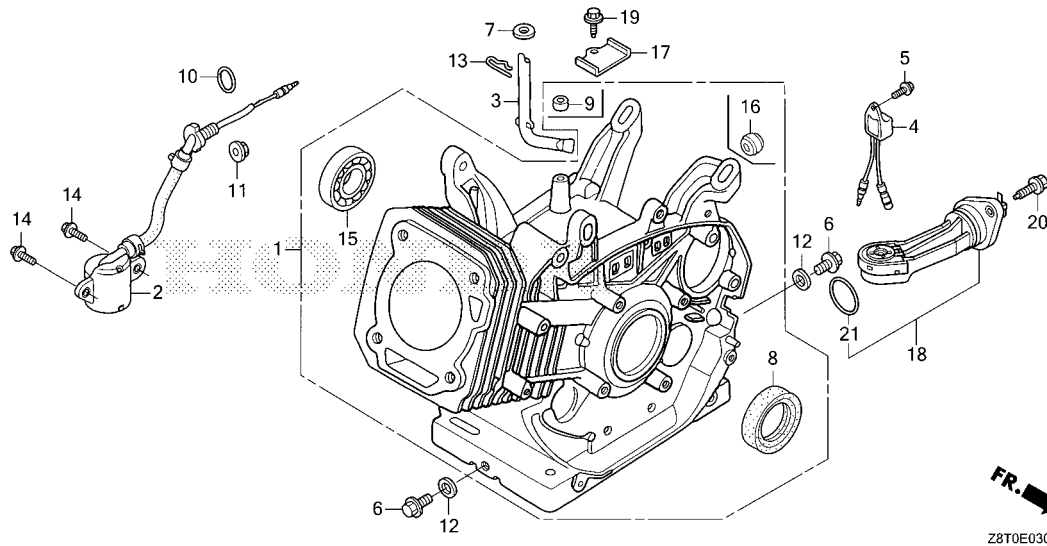

Ref. No. L.O.N. (Relative ref. Number) Description F.R.T.

Ref. No.	Part No.	Description	Reqd. QTY					Serial No.	Parts catalogue code
			GX 340 UT1	GX 340 UT2	GX 340 RT1	GX 340 RT2	GX 340 UT2X		
1	12000-Z8T-406	BARREL ASSY., CYLINDER.....	1	-	1	-	-	HA2, HX26, LX2, LXQ4, LXU, PKT2, QA2, QA26, QAG, QAH2, QAP2, QDW9, QKA4, QXB7, QXB9, QXC4, QXC6, QXC9, QXQ4, QXU, SXQ4, VA2, VAD2, VCU, VDE2, VW12, VWC, VX16, VX8, VXB7, VXB9	
	12000-Z8T-407	1	-	1	-	-	LXE4, LXE8, QAE2, QAE6, QNB2, QNE2, QNR2, QNR6, QXE4, QXE6, QXE8, SME0, SXE4, SXE8, VWE, VWE2, VXE2, VXE7, VXE8, VXE9	
	12000-Z8T-405	1	-	-	-	-	QE, QHB4, QHQ4, SE, SHQ4	
	12000-Z5T-405	BARREL ASSY., CYLINDER (SELFSTARTER+ALERT)	-	1	-	1	-	EDE2, EDS6, LXE4, QAE2, QAE6, QNB2, QNE2, QNR2, QXE4, QXE6, QXE8, SME0, SXE4, SXE8, VWE, VWE2, VXE2, VXE2/A, VXE8, VXE9	
	12000-Z5T-407	BARREL ASSY., CYLINDER(ALERT)	-	1	-	1	-	EDN2, EDT6, HA2, HX26, LX2, LXQ4, LXU, PKT2, PKX2, QA2, QAG, QAH2, QAP2, QDW9, QKA4, QMT2, QWC, QXB7, QXB9, QXQ4, QXU, QXU/A, SMX2, SXQ4, VA2, VDE2, VWC, VWS, VWS1, VX16, VX8, VXB7, VXB9	
	12000-Z5T-406	BARREL ASSY., CYLINDER.....	-	1	-	-	-	QE, QHB4, QHQ4, SE, SHQ4, SHQ4/A	
	12000-Z5T-Q20	BARREL ASSY., CYLINDER (SELFSTARTER+ALERT)	-	1	-	-	-	QZA2, QZAV, QZN2, QZX4	
	12000-Z5T-405	-	1	-	-	-	2018379 QAE2/A, QAE6/A, QNE2/A, QNR2/A, QXE4/A, SE2, SME0/A, SXE4/A, VXE8/A	
	12000-Z5T-407	BARREL ASSY., CYLINDER(ALERT)	-	1	-	-	-	2018427 HA2/A, HX26/A, LXQ4/A, PKT2/A, PKX2/A, QA2/A, QAH2/A, QAP2/A, QKA4/A, QMT2/A, QWC/A, QXB7/A, QXC9, QXQ4/A, SXQ4/A, VX16/A, VX8/A	
	12000-Z5T-406	BARREL ASSY., CYLINDER.....	-	1	-	-	-	2019694 QE/A, QHB4/A, SE/A, SE1	
	12000-Z5T-415	BARREL ASSY., CYLINDER (SELFSTARTER+ALERT)	-	1	-	-	-	2018380 QAE2/A, QAE6/A, QNE2/A, QNR2/A, QXE4/A, SE2, SME0/A, SXE4/A, VXE8/A	
	12000-Z5T-417	BARREL ASSY., CYLINDER(ALERT)	-	1	-	-	-	2018428 HA2/A, HX26/A, LXQ4/A, PKT2/A, PKX2/A, QA2/A, QAH2/A, QAP2/A, QKA4/A, QMT2/A, QWC/A, QXB7/A, QXC9, QXQ4/A, SXQ4/A, VX16/A, VX8/A	
	12000-Z5T-416	BARREL ASSY., CYLINDER.....	-	1	-	-	-	2019695 QE/A, QHB4/A, SE/A, SE1	
	12000-Z5T-407	BARREL ASSY., CYLINDER(ALERT)	-	-	-	1	-	2018475 EDN2/A, EDT6/A, VWC/A, VWS1/A	



E-3

CYLINDER BARREL

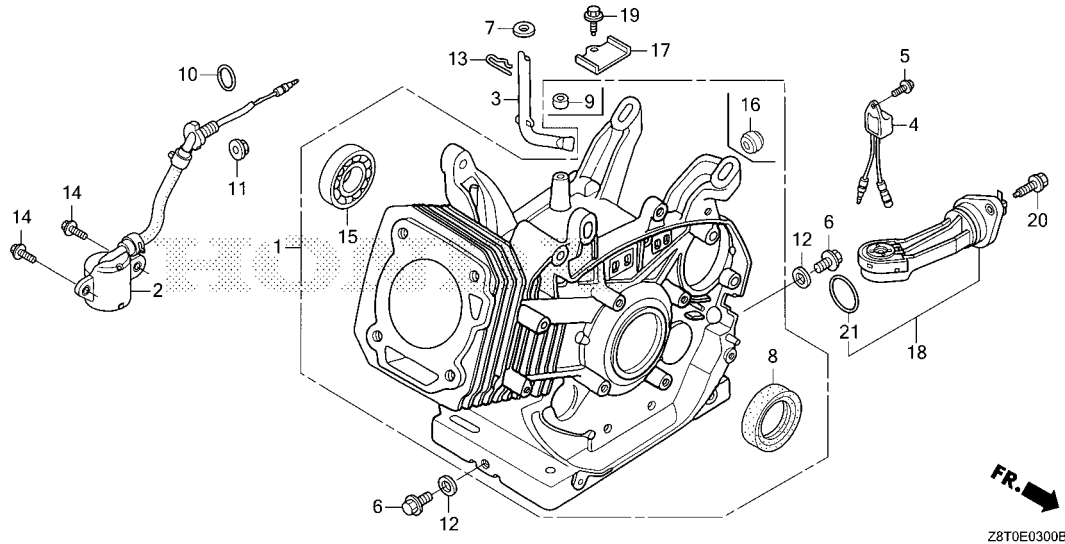

Z8T0E0300B

Ref. No.	Part No.	Description	Reqd. QTY					Serial No.	Parts catalogue code
			GX 340 UT1	GX 340 UT2	GX 340 RT1	GX 340 RT2	GX 340 UT2X		
(1)	12000-Z5T-405	BARREL ASSY., CYLINDER (SELFSTARTER+ALERT)	-	-	-	1	-	2018547	EDE2/A, EDS6/A, VWE/A, VWE2/A
	12000-Z5T-417	BARREL ASSY., CYLINDER(ALERT)	-	-	-	1	-	2018476	EDN2/A, EDT6/A, VWC/A, VWS1/A
	12000-Z5T-415	BARREL ASSY., CYLINDER (SELFSTARTER+ALERT)	-	-	-	1	-	2018548	EDE2/A, EDS6/A, VWE/A, VWE2/A
	12000-Z5T-417	BARREL ASSY., CYLINDER(ALERT)	-	-	-	-	1	-	HA2, HX26, LXQ4, PKT2, PKX2, QA2, QAH2, QAP2, QKA4, QMT2, QWC, QXB7, QXQ4, SXQ4, VX8
	12000-Z5T-415	BARREL ASSY., CYLINDER (SELFSTARTER+ALERT)	-	-	-	-	1	-	QAE2, QAE6, QNE2, QNR2, QXE4, SE2, SME0, SXE4, VXE8
	12000-Z5T-416	BARREL ASSY., CYLINDER	-	-	-	-	1	-	QE, QHB4, SE, SE1
2	35480-ZF6-003	SWITCH ASSY., OIL LEVEL	1	-	1	1	-	-	EDE2, EDE2/A, EDN2, EDN2/A, EDS6, EDS6/A, EDT6, EDT6/A, HA2, HX26, LX2, LXQ4, LXU, PKT2, QA2, QA26, QAG, QAH2, QAP2, QDW9, QKA4, QNB2, QXB7, QXB9, QXC4, QXC6, QXC9, QXQ4, QXU, SXQ4, VA2, VAD2, VC2, VDE2, VW12, VWC, VWC/A, VWE, VWE/A, VWE2, VWE2/A, VWS, VWS1, VWS1/A, VX16, VX8, VXB7, VXB9
	15510-ZE2-053	1	-	-	-	-	1000897	LXE4, LXE8, QAE2, QAE6, QNE2, QNR2, QNR6, QXE4, QXE6, QXE8, SME0, SXE4, SXE8, VXE2, VXE7, VXE8, VXE9
	35480-ZF6-003	1	-	-	-	-	1000898	LXE4, LXE8, QAE2, QAE6, QNE2, QNR2, QNR6, QXE4, QXE6, QXE8, SME0, SXE4, SXE8, VXE2, VXE7, VXE8, VXE9
		-	1	-	-	1	-	HA2, HA2/A, HX26, HX26/A, LX2, LXE4, LXQ4, LXQ4/A, LXU, PKT2, PKT2/A, PKX2, PKX2/A, QA2, QA2/A, QAE2, QAE2/A, QAE6, QAE6/A, QAG, QAH2, QAH2/A, QAP2, QAP2/A, QDW9, QKA4, QKA4/A, QMT2, QMT2/A, QNE2, QNE2/A, QNR2, QNR2/A, QWC, QWC/A, QXB7, QXB7/A, QXB9, QXC9, QXE4, QXE4/A, QXE6, QXE8, QXQ4, QXQ4/A, QXU, QXU/A, SE2, SME0, SME0/A, SMX2, SXE4, SXE4/A, SXE8, SXQ4, SXQ4/A, VA2, VX16, VX16/A, VX8, VX8/A, VXB7, VXB9, VXE2, VXE2/A, VXE8, VXE8/A, VXE9



E-3

CYLINDER BARREL

Ref. No.	Part No.	Description	Reqd. QTY					Serial No.	Parts catalogue code
			GX 340 UT1	GX 340 UT2	GX 340 RT1	GX 340 RT2	GX 340 UT2X		
3	16541-ZE3-010	SHAFT, GOVERNOR ARM.....	1	1	1	1	1	EDE2, EDE2/A, EDN2, EDN2/A, EDS6, EDS6/A, EDT6, EDT6/A, HA2, HA2/A, HX26, HX26/A, LX2, LX4, LX8, LXQ4, LXQ4/A, LXU, PKT2, PKT2/A, PKX2, PKX2/A, QA2, QA2/A, QA26, QAE2, QAE2/A, QAE6, QAE6/A, QAG, QAH2, QAH2/A, QAP2, QAP2/A, QDW9, QE, QE/A, QHB4, QHB4/A, QHQ4, QKA4, QKA4/A, QMT2, QMT2/A, QNB2, QNE2, QNE2/A, QNR2, QNR2/A, QNR6, QWC, QWC/A, QXB7, QXB7/A, QXB9, QXC4, QXC6, QXC9, QXE4, QXE4/A, QXE6, QXE8, QXQ4, QXQ4/A, QXU, QXU/A, SE, SE/A, SE1, SE2, SHQ4, SHQ4/A, SME0, SME0/A, SMX2, SXE4, SXE4/A, SXE8, SXQ4, SXQ4/A, VAD2, VAD2, VC2, VDE2, VW12, VWC, VWC/A, VWE, VWE/A, VWE2, VWE2/A, VWS, VWS1, VWS1/A, VX16, VX16/A, VX8, VX8/A, VXB7, VXB9, VXE2, VXE2/A, VXE7, VXE8, VXE8/A, VXE9	
4	34150-ZH7-013	ALERT UNIT, OIL.....	1	-	1	-	-	HA2, HX26, LX2, LXQ4, LXU, PKT2, QA2, QA26, QAG, QAH2, QAP2, QDW9, QKA4, QNB2, QXB7, QXB9, QXC4, QXC6, QXC9, QXQ4, QXU, SXQ4, VA2, VAD2, VC2, VDE2, VW12, VWC, VWE, VX16, VX8, VXB7, VXB9	
5	90013-883-000	BOLT, FLANGE, 6X12(CT200)....	1	-	1	-	-	HA2, HX26, LX2, LXQ4, LXU, PKT2, QA2, QA26, QAG, QAH2, QAP2, QDW9, QKA4, QNB2, QXB7, QXB9, QXC4, QXC6, QXC9, QXQ4, QXU, SXQ4, VA2, VAD2, VC2, VDE2, VW12, VWC, VWE, VX16, VX8, VXB7, VXB9	
6	90131-883-000	BOLT, DRAIN PLUG, 12X15.....	2	2	2	2	2		
7	90446-KE1-000	WASHER, 8.2X17X0.8.....	1	1	1	1	1	EDE2, EDE2/A, EDN2, EDN2/A, EDS6, EDS6/A, EDT6, EDT6/A, HA2, HA2/A, HX26, HX26/A, LX2, LX4, LX8, LXQ4, LXQ4/A, LXU, PKT2, PKT2/A, PKX2, PKX2/A, QA2, QA2/A, QA26, QAE2, QAE2/A, QAE6, QAE6/A, QAG, QAH2, QAH2/A, QAP2, QAP2/A, QDW9, QE, QE/A, QHB4, QHB4/A, QHQ4, QKA4, QKA4/A, QMT2, QMT2/A, QNB2, QNE2, QNE2/A, QNR2, QNR2/A, QNR6, QWC, QWC/A, QXB7, QXB7/A, QXB9, QXC4, QXC6, QXC9, QXE4, QXE4/A, QXE6, QXE8, QXQ4, QXQ4/A, QXU, QXU/A, SE, SE/A, SE1, SE2, SHQ4, SHQ4/A, SME0, SME0/A, SMX2, SXE4, SXE4/A, SXE8, SXQ4, SXQ4/A, VAD2, VAD2, VC2, VDE2, VW12, VWC, VWC/A, VWE, VWE/A, VWE2, VWE2/A, VWS, VWS1, VWS1/A, VX16, VX16/A, VX8, VX8/A, VXB7, VXB9, VXE2, VXE2/A, VXE7, VXE8, VXE8/A, VXE9	
8	91201-Z1C-003 91201-Z7E-003	OIL SEAL, 35X52X8(NOK)..... OIL SEAL, 35X52X8.....	1 -	1 1	1 -	1 1	1 1	EDE2, EDE2/A, EDN2, EDN2/A, EDS6, EDS6/A, EDT6, EDT6/A, HA2, HA2/A, HX26, HX26/A, LXQ4, LXQ4/A, PKT2, PKT2/A, PKX2, PKX2/A, QA2, QA2/A, QAE2, QAE2/A, QAE6, QAE6/A, QAH2, QAH2/A, QAP2, QAP2/A, QE, QE/A, QHB4, QHB4/A, QKA4, QKA4/A, QMT2, QMT2/A, QNE2, QNE2/A, QNR2, QNR2/A, QWC, QWC/A, QXB7, QXB7/A, QXB9, QXC4, QXC6, QXC9, QXE4, QXE4/A, QXQ4, QXQ4/A, SE, SE/A, SE1, SE2, SME0, SME0/A, SXE4, SXE4/A, SXQ4, SXQ4/A, VWC, VWC/A, VWE, VWE/A, VWE2, VWE2/A, VWS1, VWS1/A, VX16, VX16/A, VX8, VX8/A, VXB7, VXB9, VXE2, VXE2/A, VXE7, VXE8, VXE8/A, VXE9	
9	91203-952-771	OIL SEAL, 8X14X5.....	1	1	1	1	1	EDE2, EDE2/A, EDN2, EDN2/A, EDS6, EDS6/A, EDT6, EDT6/A, HA2, HA2/A, HX26, HX26/A, LX2, LX4, LX8, LXQ4, LXQ4/A, LXU, PKT2, PKT2/A, PKX2, PKX2/A, QA2, QA2/A, QA26, QAE2, QAE2/A, QAE6, QAE6/A, QAG, QAH2, QAH2/A, QAP2, QAP2/A, QDW9, QE, QE/A, QHB4, QHB4/A, QHQ4, QKA4, QKA4/A, QMT2, QMT2/A, QNB2, QNE2, QNE2/A, QNR2, QNR2/A, QNR6, QWC, QWC/A, QXB7, QXB7/A, QXB9, QXC4, QXC6, QXC9, QXE4, QXE4/A, QXE6, QXE8, QXQ4, QXQ4/A, QXU, QXU/A, SE, SE/A, SE1, SE2, SHQ4, SHQ4/A, SME0, SME0/A, SMX2, SXE4, SXE4/A, SXE8, SXQ4, SXQ4/A, VAD2, VAD2, VC2, VDE2, VW12, VWC, VWC/A, VWE, VWE/A, VWE2, VWE2/A, VWS, VWS1, VWS1/A, VX16, VX16/A, VX8, VX8/A, VXB7, VXB9, VXE2, VXE2/A, VXE7, VXE8, VXE8/A, VXE9	
	91203-Z7E-003	-	1	-	1	1	EDE2, EDE2/A, EDN2, EDN2/A, EDS6, EDS6/A, EDT6, EDT6/A, HA2, HA2/A, HX26, HX26/A, LXQ4, LXQ4/A, PKT2, PKT2/A, PKX2, PKX2/A, QA2, QA2/A, QAE2, QAE2/A, QAE6, QAE6/A, QAH2, QAH2/A, QAP2, QAP2/A, QE, QE/A, QHB4, QHB4/A, QKA4, QKA4/A, QMT2, QMT2/A, QNE2, QNE2/A, QNR2, QNR2/A, QNR6, QWC, QWC/A, QXB7, QXB7/A, QXC9, QXE4, QXE4/A, QXQ4, QXQ4/A, SE, SE/A, SE1, SE2, SME0, SME0/A, SXE4, SXE4/A, SXQ4, SXQ4/A, VWC, VWC/A, VWE, VWE/A, VWE2, VWE2/A, VWS1, VWS1/A, VX16, VX16/A, VX8, VX8/A, VXB7, VXB9, VXE2, VXE2/A, VXE7, VXE8, VXE8/A, VXE9	



E-3

CYLINDER BARREL

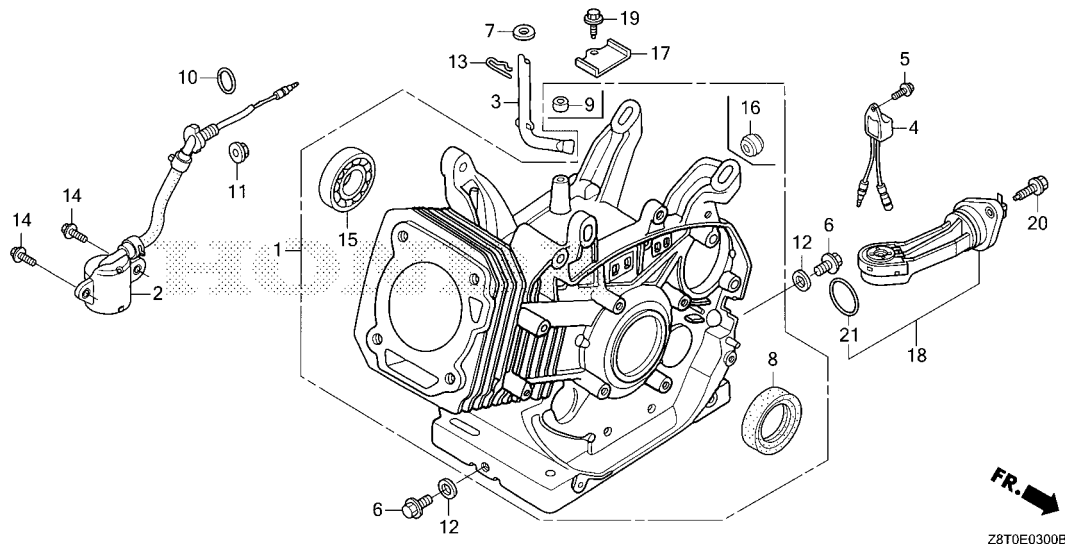

Z8T0E0300B

Ref. No.	Part No.	Description	Reqd. QTY					Serial No.	Parts catalogue code
			GX 340 UT1	GX 340 UT2	GX 340 RT1	GX 340 RT2	GX 340 UT2X		
10	91353-671-004	O-RING, 14MM(NOK)	1	1	1	1	1	-----	EDE2, EDE2/A, EDN2, EDN2/A, EDS6, EDS6/A, EDT6, EDT6/A, HA2, HA2/A, HX26, HX26/A, LX2, LXE4, LXE8, LXQ4, LXQ4/A, LXU, PKT2, PKT2/A, PKX2, PKX2/A, QA2, QA2/A, QA26, QAE2, QAE2/A, QAE6, QAE6/A, QAG, QAH2, QAH2/A, QAP2, QAP2/A, QDW9, QKA4, QKA4/A, QMT2, QMT2/A, QNB2, QNE2, QNE2/A, QNR2, QNR2/A, QNR6, QWC, QWC/A, QXB7, QXB7/A, QXB9, QXC4, QXC6, QXC9, QXE4, QXE4/A, QXE6, QXE8, QXQ4, QXQ4/A, QXU, QXU/A, SE2, SME0, SME0/A, SMX2, SXE4, SXE4/A, SXE8, SXQ4, SXQ4/A, VA2, VAD2, VC2, VDE2, VW12, VWC, VWC/A, VWE, VWE/A, VWE2, VWE2/A, VWS, VWS1, VWS1/A, VX16, VX16/A, VX8, VX8/A, VXB7, VXB9, VXE2, VXE2/A, VXE7, VXE8, VXE8/A, VXE9
11	94050-10000	NUT, FLANGE, 10MM	1	1	1	1	1	-----	EDE2, EDE2/A, EDN2, EDN2/A, EDS6, EDS6/A, EDT6, EDT6/A, HA2, HA2/A, HX26, HX26/A, LX2, LXE4, LXE8, LXQ4, LXQ4/A, LXU, PKT2, PKT2/A, PKX2, PKX2/A, QA2, QA2/A, QA26, QAE2, QAE2/A, QAE6, QAE6/A, QAG, QAH2, QAH2/A, QAP2, QAP2/A, QDW9, QKA4, QKA4/A, QMT2, QMT2/A, QNB2, QNE2, QNE2/A, QNR2, QNR2/A, QNR6, QWC, QWC/A, QXB7, QXB7/A, QXB9, QXC4, QXC6, QXC9, QXE4, QXE4/A, QXE6, QXE8, QXQ4, QXQ4/A, QXU, QXU/A, SE2, SME0, SME0/A, SMX2, SXE4, SXE4/A, SXE8, SXQ4, SXQ4/A, VA2, VAD2, VC2, VDE2, VW12, VWC, VWC/A, VWE, VWE/A, VWE2, VWE2/A, VWS, VWS1, VWS1/A, VX16, VX16/A, VX8, VX8/A, VXB7, VXB9, VXE2, VXE2/A, VXE7, VXE8, VXE8/A, VXE9
12	94109-12000	WASHER, DRAIN PLUG, 12MM	2	2	2	2	2		

E-3

CYLINDER BARREL

Ref. No.	Part No.	Description	Reqd. QTY					Serial No.	Parts catalogue code	
			GX 340 UT1	GX 340 UT2	GX 340 RT1	GX 340 RT2	GX 340 UT2X			
13	94251-10000	PIN, LOCK, 10MM.....	1	1	1	1	1	-----	EDE2, EDE2/A, EDN2, EDN2/A, EDS6, EDS6/A, EDT6, EDT6/A, HA2, HA2/A, HX26, HX26/A, LX2, LX4, LX8, LXQ4, LXQ4/A, LXU, PKT2, PKT2/A, PKX2, PKX2/A, QA2, QA2/A, QA26, QAE2, QAE2/A, QAE6, QAE6/A, QAG, QAH2, QAH2/A, QAP2, QAP2/A, QDW9, QE, QE/A, QHB4, QHB4/A, QHQ4, QKA4, QKA4/A, QMT2, QMT2/A, QNB2, QNE2, QNE2/A, QNR2, QNR2/A, QNR6, QWC, QWC/A, QXB7, QXB7/A, QXB9, QXC4, QXC6, QXC9, QXE4, QXE4/A, QXE6, QXE8, QXQ4, QXQ4/A, QXU, QXU/A, SE, SE/A, SE1, SE2, SHQ4, SHQ4/A, SME0, SME0/A, SMX2, SXE4, SXE4/A, SXE8, SXQ4, SXQ4/A, VA2, VAD2, VC2, VDE2, VW12, VWC, VWC/A, VWE, VWE/A, VWE2, VWE2/A, VWS, VWS1, VWS1/A, VX16, VX16/A, VX8, VX8/A, VXB7, VXB9, VXE2, VXE2/A, VXE7, VXE8, VXE8/A, VXE9	
14	95701-06012-00	BOLT, FLANGE, 6X12.....	2	2	2	2	2	-----	EDE2, EDE2/A, EDN2, EDN2/A, EDS6, EDS6/A, EDT6, EDT6/A, HA2, HA2/A, HX26, HX26/A, LX2, LX4, LX8, LXQ4, LXQ4/A, LXU, PKT2, PKT2/A, PKX2, PKX2/A, QA2, QA2/A, QA26, QAE2, QAE2/A, QAE6, QAE6/A, QAG, QAH2, QAH2/A, QAP2, QAP2/A, QDW9, QKA4, QKA4/A, QMT2, QMT2/A, QNB2, QNE2, QNE2/A, QNR2, QNR2/A, QNR6, QWC, QWC/A, QXB7, QXB7/A, QXB9, QXC4, QXC6, QXC9, QXE4, QXE4/A, QXE6, QXE8, QXQ4, QXQ4/A, QXU, QXU/A, SE2, SME0, SME0/A, SMX2, SXE4, SXE4/A, SXE8, SXQ4, SXQ4/A, VA2, VAD2, VC2, VDE2, VW12, VWC, VWC/A, VWE, VWE/A, VWE2, VWE2/A, VWS, VWS1, VWS1/A, VX16, VX16/A, VX8, VX8/A, VXB7, VXB9, VXE2, VXE2/A, VXE7, VXE8, VXE8/A, VXE9	
15	96100-62020-00 91004-KZR-602	BEARING, RADIAL BALL, 6202... BEARING, RADIAL BALL, 6202 (FUJIKOSHI)	1	1	1	1	1			
			-	1	-	-	-	2018380	-----	QAE2/A, QAE6/A, QNE2/A, QNR2/A, QXE4/A, SE2, SME0/A, SXE4/A, VXE8/A
			-	1	-	-	-	2018428	-----	HA2/A, HX26/A, LXQ4/A, PKT2/A, PKX2/A, QA2/A, QAH2/A, QAP2/A, QKA4/A, QMT2/A, QWC/A, QXB7/A, QXC9, QXQ4/A, SXQ4/A, VX16/A, VX8/A
			-	1	-	-	-	2019695	-----	QE/A, QHB4/A, SE/A, SE1
			-	-	-	1	-	2018476	-----	EDN2/A, EDT6/A, VWC/A, VWS1/A
			-	-	-	1	-	2018548	-----	EDE2/A, EDS6/A, VWE/A, VWE2/A
			-	-	-	-	1			
16	96205-10010	PLUG, CONE TYPE, 10X10.....	1	1	-	-	1	-----	-----	QE, QE/A, QHB4, QHB4/A, QHQ4, SE, SE/A, SE1, SHQ4, SHQ4/A
17	32115-Z5T-W00	BRACKET A, HARNESS.....	-	1	-	-	-	-----	-----	QZA2, QZAV, QZN2, QZX4
18	35480-Z5T-W01	SWITCH ASSY., OIL LEVEL.....	-	1	-	-	-	-----	-----	QZA2, QZAV, QZN2, QZX4
19	90013-883-000	BOLT, FLANGE, 6X12(CT200)....	-	1	-	-	-	-----	-----	QZA2, QZAV, QZN2, QZX4
20	90029-888-000	BOLT, FLANGE, 6X16(CT200)....	-	2	-	-	-	-----	-----	QZA2, QZAV, QZN2, QZX4
21	91309-Z6L-000	O-RING, 37.9X2.4.....	-	1	-	-	-	-----	-----	QZA2, QZAV, QZN2, QZX4



E-6

CRANKCASE COVER(1)

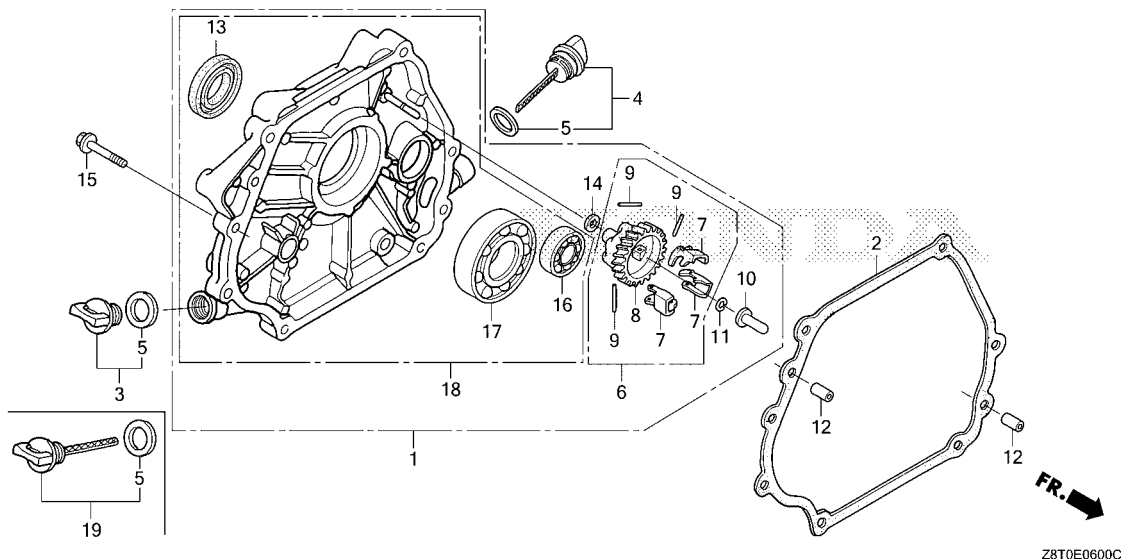

Ref. L.O.N. (Relative ref. Number) F.R.T.
No. Description

Ref. No.	Part No.	Description	Reqd. QTY					Serial No.	Parts catalogue code
			GX 340 UT1	GX 340 UT2	GX 340 RT1	GX 340 RT2	GX 340 UT2X		
1	11300-Z1C-000	COVER ASSY., CRANKCASE	1	1	-	1	-	EDE2, EDN2, EDS6, EDT6, PKX2, SE, SHQ4, SHQ4/A, SME0, SMX2, SXE4, SXE8, SXQ4, VWS1	
	11300-Z1C-600		1	-	1	1	-	PKT2, QA2, QA26, QAE2, QAE6, QAG, QAH2, QAP2, QDW9, QE, QHB4, QHQ4, QKA4, QNB2, QNE2, QNR2, QNR6, QXB7, QXB9, QXC4, QXC6, QXC9, QXE4, QXE6, QXE8, QXQ4, QXU, VA2, VAD2, VC2, VDE2, VW12, VWC, VWC/A, VWE, VWE/A, VWE2, VWE2/A, VX16, VX8, VXB7, VXB9, VXE2, VXE7, VXE8, VXE9	
			-	1	-	-	-	PKT2, QA2, QAE2, QAE6, QAG, QAH2, QAP2, QDW9, QE, QHB4, QHQ4, QKA4, QMT2, QNE2, QNR2, QWC, QXB7, QXB9, QXE4, QXE6, QXE8, QXQ4, QXU, QXU/A, VA2, VX16, VX16/A, VX8, VXB7, VXB9, VXE2, VXE2/A, VXE8, VXE9	
			-	1	-	-	2018379	PKT2/A, QA2/A, QAE2/A, QAE6/A, QAH2/A, QAP2/A, QE/A, QHB4/A, QKA4/A, QMT2/A, QNE2/A, QNR2/A, QWC/A, QXB7/A, QXC9, QXE4/A, QXQ4/A, VX8/A, VXE8/A	
	11300-Z1C-000		-	1	-	-	2018467	PKX2/A, SE/A, SE1, SE2, SME0/A, SXE4/A, SXQ4/A	
	11300-Z1C-601		-	1	-	-	2018380	PKT2/A, QA2/A, QAE2/A, QAE6/A, QAH2/A, QAP2/A, QE/A, QHB4/A, QKA4/A, QMT2/A, QNE2/A, QNR2/A, QWC/A, QXB7/A, QXC9, QXE4/A, QXQ4/A, VX8/A, VXE8/A	
	11300-Z1C-010		-	1	-	-	2018468	PKX2/A, SE/A, SE1, SE2, SME0/A, SXE4/A, SXQ4/A	
	11300-Z8W-800	COVER ASSY., CRANKCASE(S-TYPE)	-	-	-	1	-	VWS, VWS1/A	
	11300-Z1C-000	COVER ASSY., CRANKCASE	-	-	-	1	-	EDE2/A, EDN2/A, EDS6/A, EDT6/A	
	11300-Z1C-010		-	-	-	1	2018476	EDE2/A, EDN2/A, EDS6/A, EDT6/A	
	11300-Z1C-601		-	-	-	1	-	PKT2, QA2, QAE2, QAE6, QAH2, QAP2, QE, QHB4, QKA4, QMT2, QNE2, QNR2, QWC, QXB7, QXE4, QXQ4, VX8, VXE8	
	11300-Z1C-010		-	-	-	1	-	PKX2, SE, SE1, SE2, SME0, SXE4, SXQ4	
2	11381-ZE3-801	PACKING, CASE COVER	1	-	1	-	-	PKT2, QA2, QA26, QAE2, QAE6, QAG, QAH2, QAP2, QDW9, QE, QHB4, QHQ4, QKA4, QNB2, QNE2, QNR2, QNR6, QXB7, QXB9, QXC4, QXC6, QXC9, QXE4, QXE6, QXE8, QXQ4, QXU, SE, SHQ4, SME0, SXE4, SXE8, SXQ4, VA2, VAD2, VC2, VDE2, VW12, VWC, VWE, VWE2, VX16, VX8, VXB7, VXB9, VXE2, VXE7, VXE8, VXE9	

E-6

CRANKCASE COVER(1)

Ref. No.	Part No.	Description	Reqd. QTY					Serial No.	Parts catalogue code
			GX 340 UT1	GX 340 UT2	GX 340 RT1	GX 340 RT2	GX 340 UT2X		
(2)	11381-Z5T-000	PACKING, CRANKCASE COVER.....	-	1	-	1	1	-----	EDE2, EDE2/A, EDN2, EDN2/A, EDS6, EDS6/A, EDT6, EDT6/A, PKT2, PKT2/A, PKX2, PKX2/A, QA2, QA2/A, QAE2, QAE2/A, QAE6, QAE6/A, QAG, QAH2, QAH2/A, QAP2, QAP2/A, QDW9, QE, QE/A, QHB4, QHB4/A, QHQ4, QKA4, QKA4/A, QMT2, QMT2/A, QNB2, QNE2, QNE2/A, QNR2, QNR2/A, QWC, QWC/A, QXB7, QXB7/A, QXB9, QXC9, QXE4, QXE4/A, QXE6, QXE8, QXQ4, QXQ4/A, QXU, QXU/A, SE, SE/A, SE1, SE2, SHQ4, SHQ4/A, SME0, SME0/A, SMX2, SXE4, SXE4/A, SXE8, SXQ4, SXQ4/A, VA2, VDE2, VWC, VWC/A, VWE, VWE/A, VWE2, VWE2/A, VWS, VWS1, VWS1/A, VX16, VX16/A, VX8, VX8/A, VXB7, VXB9, VXE2, VXE2/A, VXE8, VXE8/A, VXE9
3	15600-Z0T-820	CAP ASSY., OIL FILLER(BLACK)·	1	1	1	1	1	-----	EDE2, EDE2/A, EDN2, EDN2/A, EDS6, EDS6/A, EDT6, EDT6/A, PKT2, PKT2/A, PKX2, PKX2/A, QA2, QA2/A, QA26, QAE2, QAE2/A, QAE6, QAE6/A, QAG, QAH2, QAH2/A, QAP2, QAP2/A, QDW9, QE, QE/A, QHB4, QHB4/A, QHQ4, QKA4, QKA4/A, QMT2, QMT2/A, QNB2, QNE2, QNE2/A, QNR2, QNR2/A, QNR6, QWC, QWC/A, QXB7, QXB7/A, QXB9, QXC4, QXC6, QXC9, QXE4, QXE4/A, QXE6, QXE8, QXQ4, QXQ4/A, QXU, QXU/A, QZA2, QZAV, QZN2, QZX4, SE, SE/A, SE1, SHQ4, SHQ4/A, SME0, SME0/A, SMX2, SXE4, SXE4/A, SXE8, SXQ4, SXQ4/A, VA2, VAD2, VC2, VDE2, VW12, VWC, VWC/A, VWE, VWE/A, VWE2, VWE2/A, VWS, VWS1, VWS1/A, VX16, VX16/A, VX8, VX8/A, VXB7, VXB9, VXE2, VXE2/A, VXE7, VXE8, VXE8/A, VXE9
4	15600-Z1C-000	CAP ASSY., OIL FILLER.....	1	1	1	1	1	-----	EDE2, EDE2/A, EDN2, EDN2/A, EDS6, EDS6/A, EDT6, EDT6/A, PKT2, PKT2/A, PKX2, PKX2/A, QA2, QA2/A, QA26, QAE2, QAE2/A, QAE6, QAE6/A, QAG, QAH2, QAH2/A, QAP2, QAP2/A, QDW9, QE, QE/A, QHB4, QHB4/A, QHQ4, QKA4, QKA4/A, QMT2, QMT2/A, QNB2, QNE2, QNE2/A, QNR2, QNR2/A, QNR6, QWC, QWC/A, QXB7, QXB7/A, QXB9, QXC4, QXC6, QXC9, QXE4, QXE4/A, QXE6, QXE8, QXQ4, QXQ4/A, QXU, QXU/A, QZA2, QZAV, QZN2, QZX4, SE, SE/A, SE1, SE2, SHQ4, SHQ4/A, SME0, SME0/A, SMX2, SXE4, SXE4/A, SXE8, SXQ4, SXQ4/A, VA2, VAD2, VC2, VDE2, VW12, VWC, VWC/A, VWE, VWE/A, VWE2, VWE2/A, VWS, VWS1, VWS1/A, VX16, VX16/A, VX8, VX8/A, VXB7, VXB9, VXE2, VXE2/A, VXE7, VXE8, VXE8/A, VXE9
5	15625-Z0T-800	PACKING, OIL FILLER CAP.....	2	2	2	2	2	-----	EDE2, EDE2/A, EDN2, EDN2/A, EDS6, EDS6/A, EDT6, EDT6/A, PKT2, PKT2/A, PKX2, PKX2/A, QA2, QA2/A, QA26, QAE2, QAE2/A, QAE6, QAE6/A, QAG, QAH2, QAH2/A, QAP2, QAP2/A, QDW9, QE, QE/A, QHB4, QHB4/A, QHQ4, QKA4, QKA4/A, QMT2, QMT2/A, QNB2, QNE2, QNE2/A, QNR2, QNR2/A, QNR6, QWC, QWC/A, QXB7, QXB7/A, QXB9, QXC4, QXC6, QXC9, QXE4, QXE4/A, QXE6, QXE8, QXQ4, QXQ4/A, QXU, QXU/A, QZA2, QZAV, QZN2, QZX4, SE, SE/A, SE1, SE2, SHQ4, SHQ4/A, SME0, SME0/A, SMX2, SXE4, SXE4/A, SXE8, SXQ4, SXQ4/A, VA2, VAD2, VC2, VDE2, VW12, VWC, VWC/A, VWE, VWE/A, VWE2, VWE2/A, VWS, VWS1, VWS1/A, VX16, VX16/A, VX8, VX8/A, VXB7, VXB9, VXE2, VXE2/A, VXE7, VXE8, VXE8/A, VXE9
6	16510-ZE3-000	GOVERNOR ASSY.	1	1	1	1	1	-----	EDE2, EDE2/A, EDN2, EDN2/A, EDS6, EDS6/A, EDT6, EDT6/A, PKT2, PKT2/A, PKX2, PKX2/A, QA2, QA2/A, QA26, QAE2, QAE2/A, QAE6, QAE6/A, QAG, QAH2, QAH2/A, QAP2, QAP2/A, QDW9, QE, QE/A, QHB4, QHB4/A, QHQ4, QKA4, QKA4/A, QMT2, QMT2/A, QNB2, QNE2, QNE2/A, QNR2, QNR2/A, QNR6, QWC, QWC/A, QXB7, QXB7/A, QXB9, QXC4, QXC6, QXC9, QXE4, QXE4/A, QXE6, QXE8, QXQ4, QXQ4/A, QXU, QXU/A, SE, SE/A, SE1, SE2, SHQ4, SHQ4/A, SME0, SME0/A, SMX2, SXE4, SXE4/A, SXE8, SXQ4, SXQ4/A, VA2, VAD2, VC2, VDE2, VW12, VWC, VWC/A, VWE, VWE/A, VWE2, VWE2/A, VWS, VWS1, VWS1/A, VX16, VX16/A, VX8, VX8/A, VXB7, VXB9, VXE2, VXE2/A, VXE7, VXE8, VXE8/A, VXE9



E-6

CRANKCASE COVER(1)

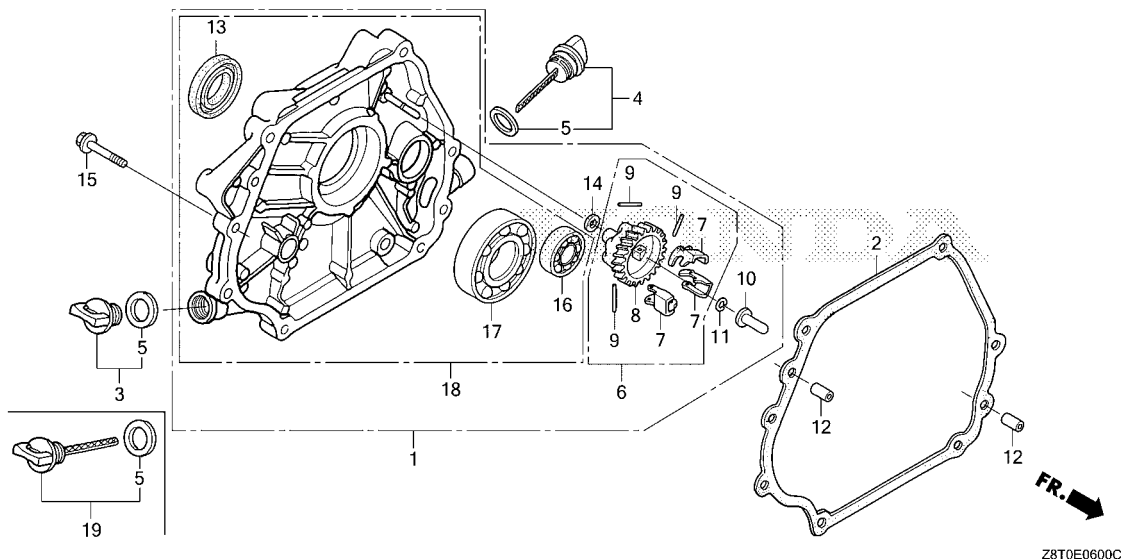

Ref. No.	Part No.	Description	Reqd. QTY					Serial No.	Parts catalogue code
			GX 340 UT1	GX 340 UT2	GX 340 RT1	GX 340 RT2	GX 340 UT2X		
7	16511-ZE8-000	WEIGHT, GOVERNOR.....	3	3	3	3	3	-----	EDE2, EDE2/A, EDN2, EDN2/A, EDS6, EDS6/A, EDT6, EDT6/A, PKT2, PKT2/A, PKX2, PKX2/A, QA2, QA2/A, QA26, QAE2, QAE2/A, QAE6, QAE6/A, QAG, QAH2, QAH2/A, QAP2, QAP2/A, QDW9, QE, QE/A, QHB4, QHB4/A, QHQ4, QKA4, QKA4/A, QMT2, QMT2/A, QNB2, QNE2, QNE2/A, QNR2, QNR2/A, QNR6, QWC, QWC/A, QXB7, QXB7/A, QXB9, QXC4, QXC6, QXC9, QXE4, QXE4/A, QXE6, QXE8, QXQ4, QXQ4/A, QXU, QXU/A, SE, SE/A, SE1, SE2, SHQ4, SHQ4/A, SME0, SME0/A, SMX2, SXE4, SXE4/A, SXE8, SXQ4, SXQ4/A, VA2, VAD2, VC2, VDE2, VW12, VWC, VWC/A, VWE, VWE/A, VWE2, VWE2/A, VWS, VWS1, VWS1/A, VX16, VX16/A, VX8, VX8/A, VXB7, VXB9, VXE2, VXE2/A, VXE7, VXE8, VXE8/A, VXE9
8	16512-ZE3-000	HOLDER, GOVERNOR WEIGHT.....	1	1	1	1	1	-----	EDE2, EDE2/A, EDN2, EDN2/A, EDS6, EDS6/A, EDT6, EDT6/A, PKT2, PKT2/A, PKX2, PKX2/A, QA2, QA2/A, QA26, QAE2, QAE2/A, QAE6, QAE6/A, QAG, QAH2, QAH2/A, QAP2, QAP2/A, QDW9, QE, QE/A, QHB4, QHB4/A, QHQ4, QKA4, QKA4/A, QMT2, QMT2/A, QNB2, QNE2, QNE2/A, QNR2, QNR2/A, QNR6, QWC, QWC/A, QXB7, QXB7/A, QXB9, QXC4, QXC6, QXC9, QXE4, QXE4/A, QXE6, QXE8, QXQ4, QXQ4/A, QXU, QXU/A, SE, SE/A, SE1, SE2, SHQ4, SHQ4/A, SME0, SME0/A, SMX2, SXE4, SXE4/A, SXE8, SXQ4, SXQ4/A, VA2, VAD2, VC2, VDE2, VW12, VWC, VWC/A, VWE, VWE/A, VWE2, VWE2/A, VWS, VWS1, VWS1/A, VX16, VX16/A, VX8, VX8/A, VXB7, VXB9, VXE2, VXE2/A, VXE7, VXE8, VXE8/A, VXE9

E-6

CRANKCASE COVER(1)

Ref. No.	Part No.	Description	Reqd. QTY					Serial No.	Parts catalogue code
			GX 340 UT1	GX 340 UT2	GX 340 RT1	GX 340 RT2	GX 340 UT2X		
9	16513-ZE2-000	PIN, GOVERNOR WEIGHT.....	3	3	3	3	3	-----	EDE2, EDE2/A, EDN2, EDN2/A, EDS6, EDS6/A, EDT6, EDT6/A, PKT2, PKT2/A, PKX2, PKX2/A, QA2, QA2/A, QA26, QAE2, QAE2/A, QAE6, QAE6/A, QAG, QAH2, QAH2/A, QAP2, QAP2/A, QDW9, QE, QE/A, QHB4, QHB4/A, QHQ4, QKA4, QKA4/A, QMT2, QMT2/A, QNB2, QNE2, QNE2/A, QNR2, QNR2/A, QNR6, QWC, QWC/A, QXB7, QXB7/A, QXB9, QXC4, QXC6, QXC9, QXE4, QXE4/A, QXE6, QXE8, QXQ4, QXQ4/A, QXU, QXU/A, SE, SE/A, SE1, SE2, SHQ4, SHQ4/A, SME0, SME0/A, SMX2, SXE4, SXE4/A, SXE8, SXQ4, SXQ4/A, VA2, VAD2, VC2, VDE2, VW12, VWC, VWC/A, VWE, VWE/A, VWE2, VWE2/A, VWS, VWS1, VWS1/A, VX16, VX16/A, VX8, VX8/A, VXB7, VXB9, VXE2, VXE2/A, VXE7, VXE8, VXE8/A, VXE9
10	16531-Z0A-000	SLIDER, GOVERNOR.....	1	1	1	1	1	-----	EDE2, EDE2/A, EDN2, EDN2/A, EDS6, EDS6/A, EDT6, EDT6/A, PKT2, PKT2/A, PKX2, PKX2/A, QA2, QA2/A, QA26, QAE2, QAE2/A, QAE6, QAE6/A, QAG, QAH2, QAH2/A, QAP2, QAP2/A, QDW9, QE, QE/A, QHB4, QHB4/A, QHQ4, QKA4, QKA4/A, QMT2, QMT2/A, QNB2, QNE2, QNE2/A, QNR2, QNR2/A, QNR6, QWC, QWC/A, QXB7, QXB7/A, QXB9, QXC4, QXC6, QXC9, QXE4, QXE4/A, QXE6, QXE8, QXQ4, QXQ4/A, QXU, QXU/A, SE, SE/A, SE1, SE2, SHQ4, SHQ4/A, SME0, SME0/A, SMX2, SXE4, SXE4/A, SXE8, SXQ4, SXQ4/A, VA2, VAD2, VC2, VDE2, VW12, VWC, VWC/A, VWE, VWE/A, VWE2, VWE2/A, VWS, VWS1, VWS1/A, VX16, VX16/A, VX8, VX8/A, VXB7, VXB9, VXE2, VXE2/A, VXE7, VXE8, VXE8/A, VXE9
11	90602-ZE1-000	CLIP, GOVERNOR HOLDER.....	1	1	1	1	1	-----	EDE2, EDE2/A, EDN2, EDN2/A, EDS6, EDS6/A, EDT6, EDT6/A, PKT2, PKT2/A, PKX2, PKX2/A, QA2, QA2/A, QA26, QAE2, QAE2/A, QAE6, QAE6/A, QAG, QAH2, QAH2/A, QAP2, QAP2/A, QDW9, QE, QE/A, QHB4, QHB4/A, QHQ4, QKA4, QKA4/A, QMT2, QMT2/A, QNB2, QNE2, QNE2/A, QNR2, QNR2/A, QNR6, QWC, QWC/A, QXB7, QXB7/A, QXB9, QXC4, QXC6, QXC9, QXE4, QXE4/A, QXE6, QXE8, QXQ4, QXQ4/A, QXU, QXU/A, SE, SE/A, SE1, SE2, SHQ4, SHQ4/A, SME0, SME0/A, SMX2, SXE4, SXE4/A, SXE8, SXQ4, SXQ4/A, VA2, VAD2, VC2, VDE2, VW12, VWC, VWC/A, VWE, VWE/A, VWE2, VWE2/A, VWS, VWS1, VWS1/A, VX16, VX16/A, VX8, VX8/A, VXB7, VXB9, VXE2, VXE2/A, VXE7, VXE8, VXE8/A, VXE9
12	90701-HC4-000	DOWEL PIN, 8X12.....	2	2	2	2	2	-----	EDE2, EDE2/A, EDN2, EDN2/A, EDS6, EDS6/A, EDT6, EDT6/A, PKT2, PKT2/A, PKX2, PKX2/A, QA2, QA2/A, QA26, QAE2, QAE2/A, QAE6, QAE6/A, QAG, QAH2, QAH2/A, QAP2, QAP2/A, QDW9, QE, QE/A, QHB4, QHB4/A, QHQ4, QKA4, QKA4/A, QMT2, QMT2/A, QNB2, QNE2, QNE2/A, QNR2, QNR2/A, QNR6, QWC, QWC/A, QXB7, QXB7/A, QXB9, QXC4, QXC6, QXC9, QXE4, QXE4/A, QXE6, QXE8, QXQ4, QXQ4/A, QXU, QXU/A, QZA2, QZAV, QZN2, QZX4, SE, SE/A, SE1, SE2, SHQ4, SHQ4/A, SME0, SME0/A, SMX2, SXE4, SXE4/A, SXE8, SXQ4, SXQ4/A, VA2, VAD2, VC2, VDE2, VW12, VWC, VWC/A, VWE, VWE/A, VWE2, VWE2/A, VWS, VWS1, VWS1/A, VX16, VX16/A, VX8, VX8/A, VXB7, VXB9, VXE2, VXE2/A, VXE7, VXE8, VXE8/A, VXE9
13	91201-Z1C-003	OIL SEAL, 35X52X8(NOK).....	1	1	1	1	1	-----	EDE2, EDE2/A, EDN2, EDN2/A, EDS6, EDS6/A, EDT6, EDT6/A, PKT2, PKT2/A, PKX2, PKX2/A, QA2, QA2/A, QA26, QAE2, QAE2/A, QAE6, QAE6/A, QAG, QAH2, QAH2/A, QAP2, QAP2/A, QDW9, QE, QE/A, QHB4, QHB4/A, QHQ4, QKA4, QKA4/A, QMT2, QMT2/A, QNB2, QNE2, QNE2/A, QNR2, QNR2/A, QNR6, QWC, QWC/A, QXB7, QXB7/A, QXB9, QXC4, QXC6, QXC9, QXE4, QXE4/A, QXE6, QXE8, QXQ4, QXQ4/A, QXU, QXU/A, QZA2, QZAV, QZN2, QZX4, SE, SE/A, SE1, SE2, SHQ4, SHQ4/A, SME0, SME0/A, SMX2, SXE4, SXE4/A, SXE8, SXQ4, SXQ4/A, VA2, VAD2, VC2, VDE2, VW12, VWC, VWC/A, VWE, VWE/A, VWE2, VWE2/A, VWS, VWS1, VWS1/A, VX16, VX16/A, VX8, VX8/A, VXB7, VXB9, VXE2, VXE2/A, VXE7, VXE8, VXE8/A, VXE9



E-6

CRANKCASE COVER(1)

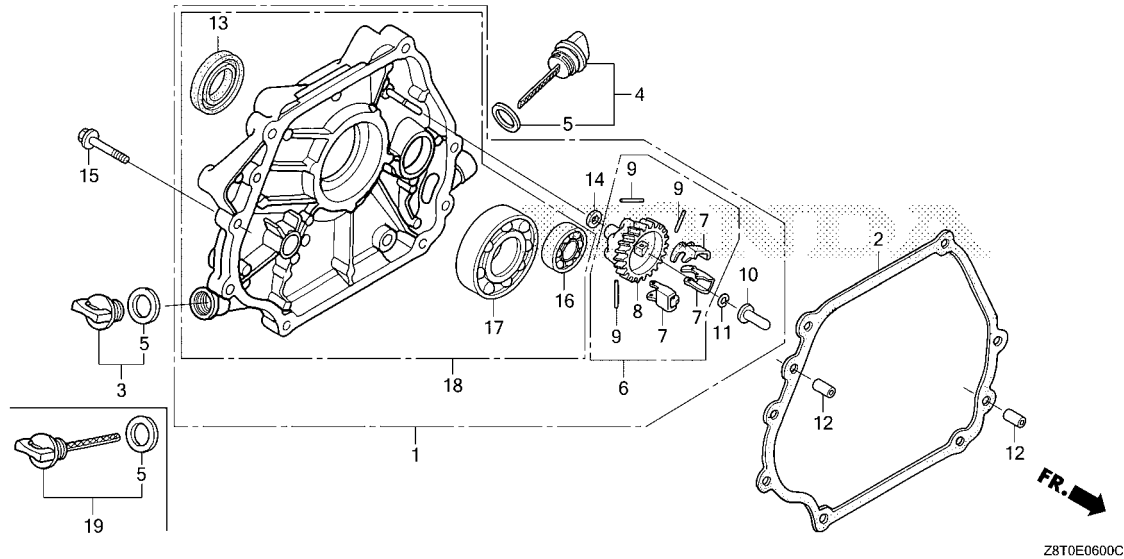

Ref. No.	Part No.	Description	Reqd. QTY					Serial No.	Parts catalogue code
			GX 340 UT1	GX 340 UT2	GX 340 RT1	GX 340 RT2	GX 340 UT2X		
14	94101-06800	WASHER, PLAIN, 6MM	1	1	1	1	1	EDE2, EDE2/A, EDN2, EDN2/A, EDS6, EDS6/A, EDT6, EDT6/A, PKT2, PKT2/A, PKX2, PKX2/A, QA2, QA2/A, QA26, QAE2, QAE2/A, QAE6, QAE6/A, QAG, QAH2, QAH2/A, QAP2, QAP2/A, QDW9, QE, QE/A, QHB4, QHB4/A, QHQ4, QKA4, QKA4/A, QMT2, QMT2/A, QNB2, QNE2, QNE2/A, QNR2, QNR2/A, QNR6, QWC, QWC/A, QXB7, QXB7/A, QXB9, QXC4, QXC6, QXC9, QXE4, QXE4/A, QXE6, QXE8, QXQ4, QXQ4/A, QXU, QXU/A, SE, SE/A, SE1, SE2, SHQ4, SHQ4/A, SME0, SME0/A, SMX2, SXE4, SXE4/A, SXE8, SXQ4, SXQ4/A, VA2, VAD2, VC2, VDE2, VW12, VWC, VWC/A, VWE, VWE/A, VWE2, VWE2/A, VWS, VWS1, VWS1/A, VX16, VX16/A, VX8, VX8/A, VXB7, VXB9, VXE2, VXE2/A, VXE7, VXE8, VXE8/A, VXE9	
15	95701-08040-00	BOLT, FLANGE, 8X40	7	7	7	7	7	EDE2, EDE2/A, EDN2, EDN2/A, EDS6, EDS6/A, EDT6, EDT6/A, PKT2, PKT2/A, PKX2, PKX2/A, QA2, QA2/A, QA26, QAE2, QAE2/A, QAE6, QAE6/A, QAG, QAH2, QAH2/A, QAP2, QAP2/A, QDW9, QE, QE/A, QHB4, QHB4/A, QHQ4, QKA4, QKA4/A, QMT2, QMT2/A, QNB2, QNE2, QNE2/A, QNR2, QNR2/A, QNR6, QWC, QWC/A, QXB7, QXB7/A, QXB9, QXC4, QXC6, QXC9, QXE4, QXE4/A, QXE6, QXE8, QXQ4, QXQ4/A, QXU, QXU/A, QZA2, QZAV, QZN2, QZX4, SE, SE/A, SE1, SE2, SHQ4, SHQ4/A, SME0, SME0/A, SMX2, SXE4, SXE4/A, SXE8, SXQ4, SXQ4/A, VA2, VAD2, VC2, VDE2, VW12, VWC, VWC/A, VWE, VWE/A, VWE2, VWE2/A, VWS, VWS1, VWS1/A, VX16, VX16/A, VX8, VX8/A, VXB7, VXB9, VXE2, VXE2/A, VXE7, VXE8, VXE8/A, VXE9	

E-6

CRANKCASE COVER(1)

Ref. No.	Part No.	Description	Reqd. QTY					Serial No.	Parts catalogue code	
			GX 340 UT1	GX 340 UT2	GX 340 RT1	GX 340 RT2	GX 340 UT2X			
16	96100-62020-00	BEARING, RADIAL BALL, 6202 ...	1	1	1	1	1	-----	EDE2, EDE2/A, EDN2, EDN2/A, EDS6, EDS6/A, EDT6, EDT6/A, PKT2, PKT2/A, PKX2, PKX2/A, QA2, QA2/A, QA26, QAE2, QAE2/A, QAE6, QAE6/A, QAG, QAH2, QAH2/A, QAP2, QAP2/A, QDW9, QE, QE/A, QHB4, QHB4/A, QHQ4, QKA4, QKA4/A, QMT2, QMT2/A, QNB2, QNE2, QNE2/A, QNR2, QNR2/A, QNR6, QWC, QWC/A, QXB7, QXB7/A, QXB9, QXC4, QXC6, QXC9, QXE4, QXE4/A, QXE6, QXE8, QXQ4, QXQ4/A, QXU, QXU/A, QZA2, QZAV, QZN2, QZX4, SE, SE/A, SE1, SE2, SHQ4, SHQ4/A, SME0, SME0/A, SMX2, SXE4, SXE4/A, SXE8, SXQ4, SXQ4/A, VA2, VAD2, VC2, VDE2, VW12, VWC, VWC/A, VWE, VWE/A, VWE2, VWE2/A, VWS, VWS1, VWS1/A, VX16, VX16/A, VX8, VX8/A, VXB7, VXB9, VXE2, VXE2/A, VXE7, VXE8, VXE8/A, VXE9	
	91004-KZR-602	BEARING, RADIAL BALL, 6202 (FUJIKOSHI)	-	1	-	-	-	2018380	-----	PKT2/A, QA2/A, QAE2/A, QAE6/A, QAH2/A, QAP2/A, QE/A, QHB4/A, QKA4/A, QMT2/A, QNE2/A, QNR2/A, QWC/A, QXB7/A, QXC9, QXE4/A, QXQ4/A, VX8/A, VXE8/A
			-	1	-	-	-	2018468	-----	PKX2/A, SE/A, SE1, SE2, SME0/A, SXE4/A, SXQ4/A
			-	-	-	1	-	2018476	-----	EDE2/A, EDN2/A, EDS6/A, EDT6/A
			-	-	-	-	1	-----	-----	PKT2, PKX2, QA2, QAE2, QAE6, QAH2, QAP2, QE, QHB4, QKA4, QMT2, QNE2, QNR2, QWC, QXB7, QXE4, QXQ4, SE, SE1, SE2, SME0, SXE4, SXQ4, VX8, VXE8
17	96100-62070-00	BEARING, RADIAL BALL, 6207 ...	1	1	1	1	1	-----	-----	EDE2, EDE2/A, EDN2, EDN2/A, EDS6, EDS6/A, EDT6, EDT6/A, PKT2, PKT2/A, PKX2, PKX2/A, QA2, QA2/A, QA26, QAE2, QAE2/A, QAE6, QAE6/A, QAG, QAH2, QAH2/A, QAP2, QAP2/A, QDW9, QE, QE/A, QHB4, QHB4/A, QHQ4, QKA4, QKA4/A, QMT2, QMT2/A, QNB2, QNE2, QNE2/A, QNR2, QNR2/A, QNR6, QWC, QWC/A, QXB7, QXB7/A, QXB9, QXC4, QXC6, QXC9, QXE4, QXE4/A, QXE6, QXE8, QXQ4, QXQ4/A, QXU, QXU/A, QZA2, QZAV, QZN2, QZX4, SE, SE/A, SE1, SE2, SHQ4, SHQ4/A, SME0, SME0/A, SMX2, SXE4, SXE4/A, SXE8, SXQ4, SXQ4/A, VA2, VAD2, VC2, VDE2, VW12, VWC, VWC/A, VWE, VWE/A, VWE2, VWE2/A, VWS, VWS1, VWS1/A, VX16, VX16/A, VX8, VX8/A, VXB7, VXB9, VXE2, VXE2/A, VXE7, VXE8, VXE8/A, VXE9
18	11300-Z5T-W10	COVER ASSY., CRANKCASE	-	1	-	-	-	-----	-----	QZA2, QZAV, QZN2, QZX4
19	15600-Z1C-000	CAP ASSY., OIL FILLER	-	1	-	-	1	-----	-----	SE2



E-6-1

CRANKCASE COVER(2)

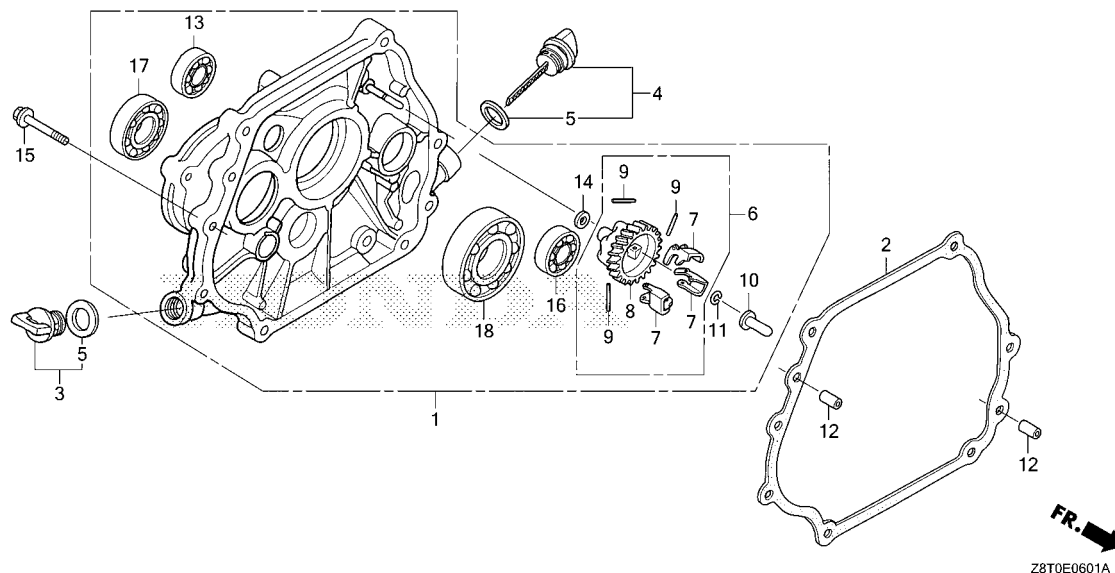

Ref. L.O.N. (Relative ref. Number) F.R.T.
No. Description

Ref. No.	Part No.	Description	Reqd. QTY					Serial No.	Parts catalogue code
			GX 340 UT1	GX 340 UT2	GX 340 RT1	GX 340 RT2	GX 340 UT2X		
1	11300-ZE3-614	COVER ASSY., CRANKCASE	1	1	-	-	-	HA2, HX26, LX2, LXE4, LXE8, LXQ4, LXU	
	11300-ZE3-615	-	1	-	-	2018427	HA2/A, HX26/A, LXQ4/A	
			-	-	-	-	2018428	HA2/A, HX26/A, LXQ4/A	
			-	-	-	-	-	HA2, HX26, LXQ4	
2	11381-ZE3-801	PACKING, CASE COVER	1	-	-	-	-	HA2, HX26, LX2, LXE4, LXE8, LXQ4, LXU	
	11381-Z5T-000	PACKING, CRANKCASE COVER	-	1	-	-	1	HA2, HA2/A, HX26, HX26/A, LX2, LXE4, LXQ4, LXQ4/A, LXU	
3	15600-Z0T-820	CAP ASSY., OIL FILLER(BLACK) ..	1	1	-	-	1	HA2, HA2/A, HX26, HX26/A, LX2, LXE4, LXE8, LXQ4, LXQ4/A, LXU	
4	15600-Z1C-000	CAP ASSY., OIL FILLER	1	1	-	-	1	HA2, HA2/A, HX26, HX26/A, LX2, LXE4, LXE8, LXQ4, LXQ4/A, LXU	
5	15625-Z0T-800	PACKING, OIL FILLER CAP	2	2	-	-	2	HA2, HA2/A, HX26, HX26/A, LX2, LXE4, LXE8, LXQ4, LXQ4/A, LXU	
6	16510-ZE3-000	GOVERNOR ASSY.	1	1	-	-	1	HA2, HA2/A, HX26, HX26/A, LX2, LXE4, LXE8, LXQ4, LXQ4/A, LXU	
7	16511-ZE8-000	WEIGHT, GOVERNOR	3	3	-	-	3	HA2, HA2/A, HX26, HX26/A, LX2, LXE4, LXE8, LXQ4, LXQ4/A, LXU	
8	16512-ZE3-000	HOLDER, GOVERNOR WEIGHT	1	1	-	-	1	HA2, HA2/A, HX26, HX26/A, LX2, LXE4, LXE8, LXQ4, LXQ4/A, LXU	
9	16513-ZE2-000	PIN, GOVERNOR WEIGHT	3	3	-	-	3	HA2, HA2/A, HX26, HX26/A, LX2, LXE4, LXE8, LXQ4, LXQ4/A, LXU	
10	16531-Z0A-000	SLIDER, GOVERNOR	1	1	-	-	1	HA2, HA2/A, HX26, HX26/A, LX2, LXE4, LXE8, LXQ4, LXQ4/A, LXU	
11	90602-ZE1-000	CLIP, GOVERNOR HOLDER	1	1	-	-	1	HA2, HA2/A, HX26, HX26/A, LX2, LXE4, LXE8, LXQ4, LXQ4/A, LXU	
12	90701-HC4-000	DOWEL PIN, 8X12	2	2	-	-	2	HA2, HA2/A, HX26, HX26/A, LX2, LXE4, LXE8, LXQ4, LXQ4/A, LXU	
13	91009-KJ1-003	BEARING, RADIAL BALL, 6202							
		(NTN)	1	1	-	-	1	HA2, HA2/A, HX26, HX26/A, LX2, LXE4, LXE8, LXQ4, LXQ4/A, LXU	
14	94101-06800	WASHER, PLAIN, 6MM	1	1	-	-	1	HA2, HA2/A, HX26, HX26/A, LX2, LXE4, LXE8, LXQ4, LXQ4/A, LXU	
15	95701-08040-00	BOLT, FLANGE, 8X40	7	7	-	-	7	HA2, HA2/A, HX26, HX26/A, LX2, LXE4, LXE8, LXQ4, LXQ4/A, LXU	
16	96100-62020-00	BEARING, RADIAL BALL, 6202 ...	1	1	-	-	1	HA2, HA2/A, HX26, HX26/A, LX2, LXE4, LXE8, LXQ4, LXQ4/A, LXU	
	91004-KZR-602	BEARING, RADIAL BALL, 6202							
		(FUJIKOSHI)	-	1	-	-	2018428	HA2/A, HX26/A, LXQ4/A	
			-	-	-	-	-	HA2, HX26, LXQ4	
17	96100-62040-00	BEARING, RADIAL BALL, 6204 ...	1	1	-	-	1	HA2, HA2/A, HX26, HX26/A, LX2, LXE4, LXE8, LXQ4, LXQ4/A, LXU	
18	96100-62070-00	BEARING, RADIAL BALL, 6207 ...	1	1	-	-	1	HA2, HA2/A, HX26, HX26/A, LX2, LXE4, LXE8, LXQ4, LXQ4/A, LXU	

CRANKSHAFT

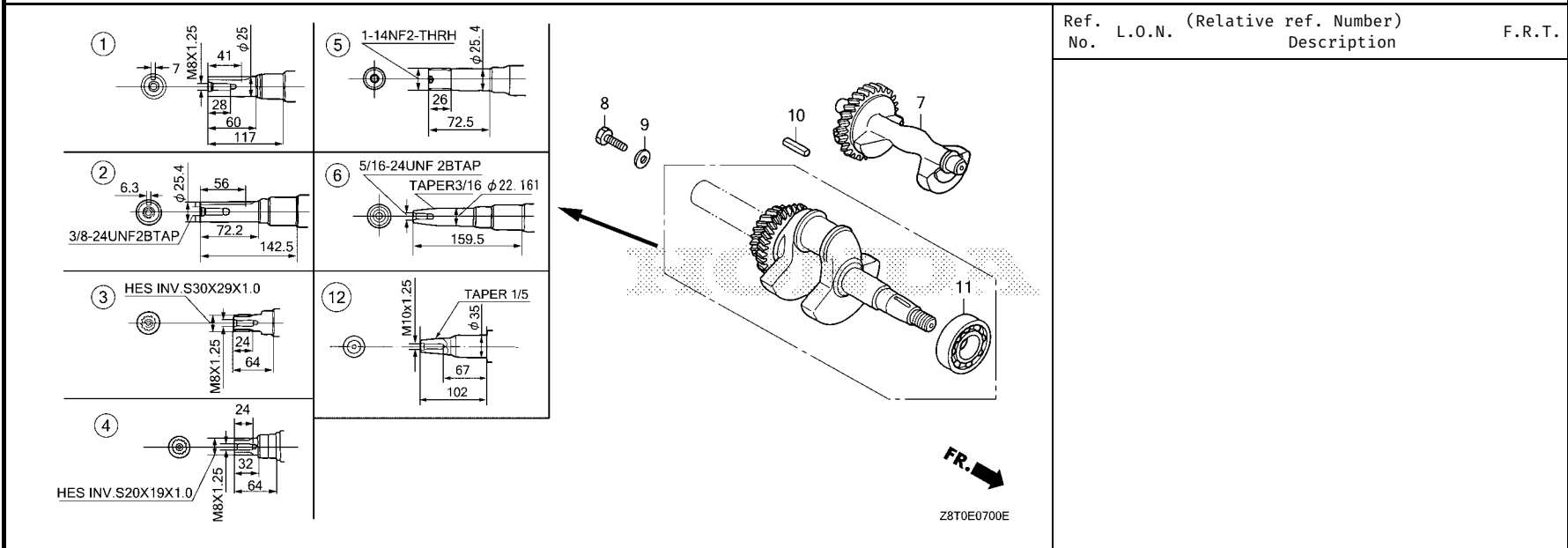

Ref. No.	L.O.N.	(Relative ref. Number) Description	F.R.T.
----------	--------	------------------------------------	--------

Ref. No.	Part No.	Description	Reqd. QTY					Serial No.	Parts catalogue code
			GX 340 UT1	GX 340 UT2	GX 340 RT1	GX 340 RT2	GX 340 UT2X		
1	13310-ZE3-020 13310-ZF6-W72	CRANKSHAFT COMP.	1	-	-	-	-	SE, SHQ4, SME0, SXE4, SXE8, SXQ4 SE, SE/A, SE1, SE2, SHQ4, SHQ4/A, SME0, SME0/A, SMX2, SXE4, SXE4/A, SXE8, SXQ4, SXQ4/A	
2	13310-ZE3-602 13310-ZK3-601 13310-ZF6-W12	CRANKSHAFT COMP.	1	-	1	-	-	QA2, QA26, QAE2, QAE6, QAG, QAH2, QAP2, QDW9, QE, QHB4, QHQ4, QKA4, QNB2, QNE2, QNR2, QNR6, QXC4, QXC6, QXC9, QXE4, QXE6, QXE8, QXQ4, QXU QXB7, QXB9 QA2, QA2/A, QAE2, QAE2/A, QAE6, QAE6/A, QAG, QAH2, QAH2/A, QAP2, QAP2/A, QDW9, QE, QE/A, QHB4, QHB4/A, QHQ4, QKA4, QKA4/A, QMT2, QMT2/A, QNB2, QNE2, QNE2/A, QNR2, QNR2/A, QWC, QWC/A, QXC9, QXE4, QXE4/A, QXE6, QXE8, QXQ4, QXQ4/A, QXU, QXU/A, QZA2, QZAV, QZN2, QZX4 QXB7, QXB7/A, QXB9	
3	13310-ZE3-612 13310-ZF6-W22	CRANKSHAFT COMP.	1	-	-	-	-	LX2, LXE4, LXE8, LXQ4, LXU LX2, LXE4, LXQ4, LXQ4/A, LXU	
4	13310-ZE3-641 13310-ZF6-W32	CRANKSHAFT COMP.	1	-	-	-	-	HA2, HX26 HA2, HA2/A, HX26, HX26/A	
5	13310-ZE3-652 13310-ZF6-W62	CRANKSHAFT COMP.	1	-	-	-	-	PKT2 PKT2, PKT2/A, PKX2, PKX2/A	
6	13310-ZE3-672 13310-ZK3-671 13310-ZF6-W42	CRANKSHAFT COMP.	1	-	1	-	-	VA2, VAD2, VC2, VDE2, VW12, VWC, VWE, VWE2, VX16, VX8, VXE2, VXE8, VXB7, VXB9, VXE7, VXE9 VA2, VDE2, VWC, VWC/A, VWE, VWE/A, VWE2, VWE2/A, VWS, VWS1, VWS1/A, VX16, VX16/A, VX8, VX8/A, VXE2, VXE2/A, VXE8, VXE8/A, VXB7, VXB9, VXE9	
7	13310-ZK6-672 13351-ZE3-010	WEIGHT, BALANCER	1	-	1	-	-		



E-7

CRANKSHAFT

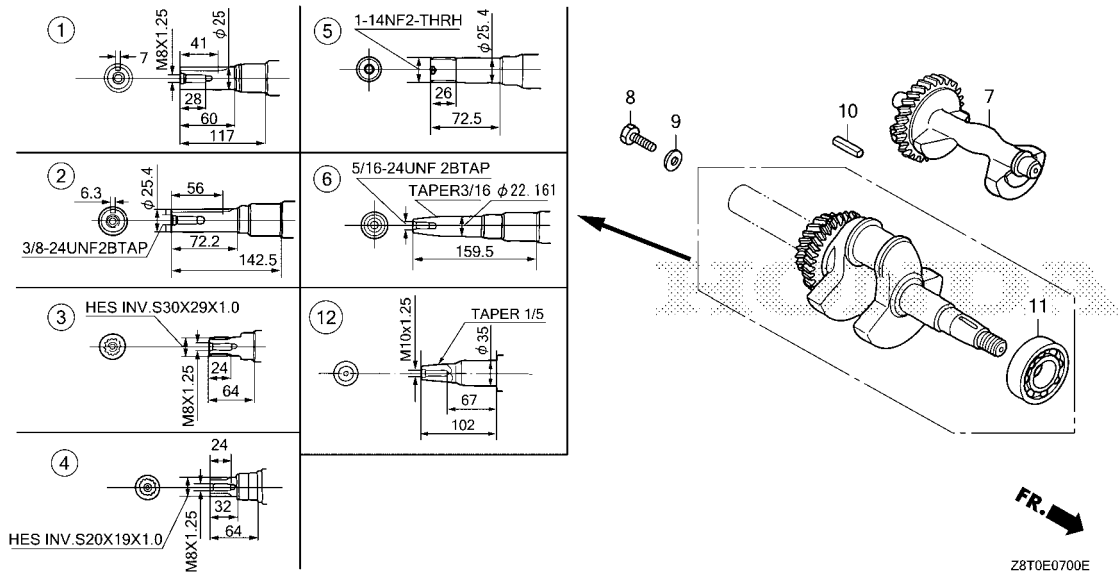

Ref. No.	Part No.	Description	Reqd. QTY					Serial No.	Parts catalogue code
			GX 340 UT1	GX 340 UT2	GX 340 RT1	GX 340 RT2	GX 340 UT2X		
(7)	13351-Z1C-900	WEIGHT, BALANCER.....	-	1	-	1	-	EDE2/A, EDN2/A, EDS6/A, EDT6/A, HA2/A, HX26/A, LXQ4/A, PKT2/A, PKX2/A, QA2/A, QAE2/A, QAE6/A, QAH2/A, QAP2/A, QE/A, QHB4/A, QKA4/A, QMT2/A, QNE2/A, QNR2/A, QWC/A, QXB7/A, QXE4/A, QXQ4/A, QXU/A, SE/A, SE1, SE2, SHQ4/A, SME0/A, SXE4/A, SXQ4/A, VVC/A, VVE/A, VWE2/A, VWS1, VWS1/A, VX16/A, VX8/A, VXE2/A, VXE8/A, HA2, HX26, LX2, LXE4, LXQ4, LXU, PKT2, PKX2, QA2, QAE2, QAE6, QAG, QAH2, QAP2, QDW9, QE, QHB4, QHQ4, QKA4, QMT2, QNE2, QNR2, QWC, QXB7, QXB9, QXC9, QXE4, QXE6, QXE8, QXQ4, QXU, QZA2, QZAV, QZN2, QZX4, SE, SHQ4, SME0, SMX2, SXE4, SXE8, SXQ4, VA2, VX16, VX8, VXB7, VXB9, VXE2, VXE8, VXE9	
	13351-ZE3-010	-	1	-	-	-	1074556	HA2, HX26, LX2, LXE4, LXQ4, LXU, PKT2, PKX2, QA2, QAE2, QAE6, QAG, QAH2, QAP2, QDW9, QE, QHB4, QHQ4, QKA4, QMT2, QNE2, QNR2, QWC, QXB7, QXB9, QXC9, QXE4, QXE6, QXE8, QXQ4, QXU, QZA2, QZAV, QZN2, QZX4, SE, SHQ4, SME0, SMX2, SXE4, SXE8, SXQ4, VA2, VX16, VX8, VXB7, VXB9, VXE2, VXE8, VXE9
	13351-Z1C-900	-	1	-	-	-	1074557	HA2, HX26, LX2, LXE4, LXQ4, LXU, PKT2, PKX2, QA2, QAE2, QAE6, QAG, QAH2, QAP2, QDW9, QE, QHB4, QHQ4, QKA4, QMT2, QNE2, QNR2, QWC, QXB7, QXB9, QXC9, QXE4, QXE6, QXE8, QXQ4, QXU, QZA2, QZAV, QZN2, QZX4, SE, SHQ4, SME0, SMX2, SXE4, SXE8, SXQ4, VA2, VX16, VX8, VXB7, VXB9, VXE2, VXE8, VXE9
	13351-ZE3-010	-	-	-	1	-	1075630	EDE2, EDN2, EDS6, EDT6, QNB2, VDE2, VVC, VVE, VWE2, VWS
	13351-Z1C-900	-	-	-	1	-	1075631	EDE2, EDN2, EDS6, EDT6, QNB2, VDE2, VVC, VWE, VWE2, VWS
	8 95701-08025-00	BOLT, FLANGE, 8X25.....	1	1	-	-	1	-	HA2, HA2/A, HX26, HX26/A
	90107-959-003	1	1	-	-	1	-	LX2, LXE4, LXE8, LXQ4, LXQ4/A, LXU
	92101-08025-0A	BOLT, HEX., 8X25.....	-	1	-	-	-	-	SMX2
	9 90473-842-000	WASHER, 8MM.....	1	1	-	-	1	-	HA2, HA2/A, HX26, HX26/A
	90473-ZE3-010	WASHER, 8.5X42X4.5.....	1	1	-	-	1	-	LX2, LXE4, LXE8, LXQ4, LXQ4/A, LXU
	90534-706-010	WASHER, LOCK, 8.5X35X4.5.....	-	1	-	-	-	-	SMX2
	10 90745-ZE2-600	KEY, 6.3X6.3X43.....	1	1	1	1	1	-	QA2, QA2/A, QA26, QAE2, QAE2/A, QAE6, QAE6/A, QAG, QAH2, QAH2/A, QAP2, QAP2/A, QDW9, QE, QE/A, QHQ4, QKA4, QKA4/A, QMT2, QMT2/A, QNB2, QNE2, QNE2/A, QNR2, QNR2/A, QNR6, QWC, QWC/A, QXB7, QXB7/A, QXB9, QXC4, QXC6, QXC9, QXE4, QXE4/A, QXE6, QXE8, QXQ4, QXQ4/A, QXU, QXU/A, QZA2, QZAV, QZN2, QZX4

E-7

CRANKSHAFT

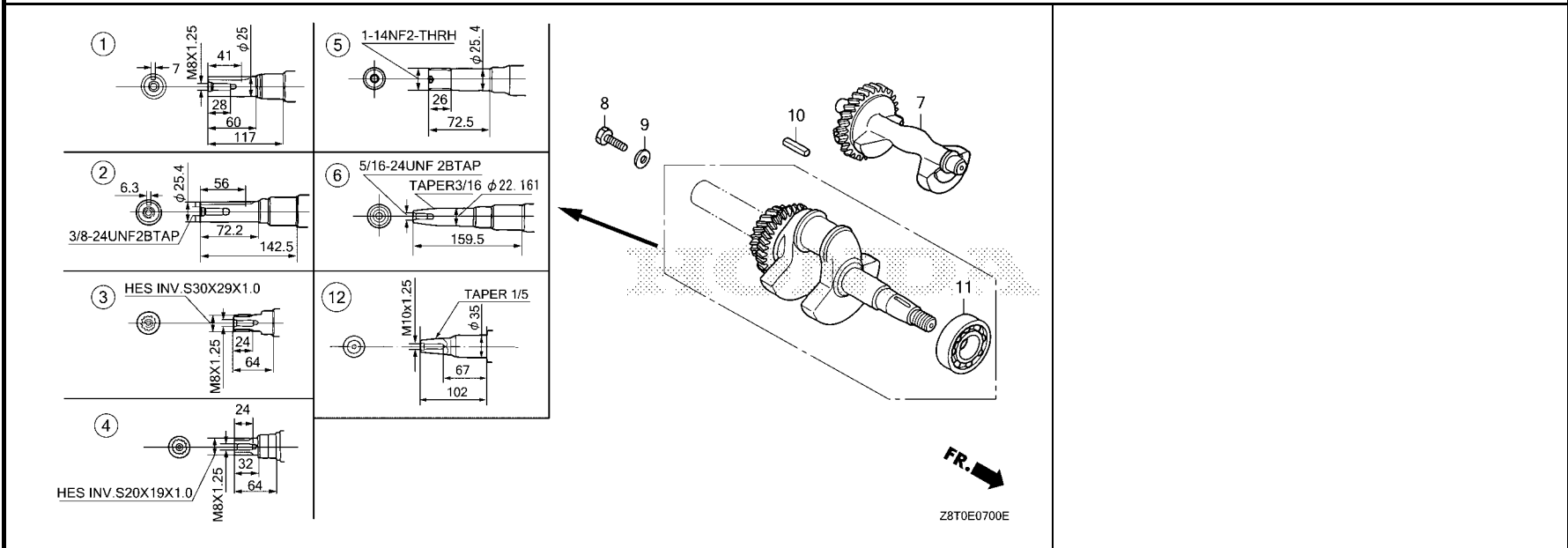

Ref. No.	Part No.	Description	Reqd. QTY					Serial No.	Parts catalogue code
			GX 340 UT1	GX 340 UT2	GX 340 RT1	GX 340 RT2	GX 340 UT2X		
10)	90741-889-810	KEY, 7X7X33(YELLOW)(O.S.).....	(1)	(1)	-	-	(1)	----- SE, SE/A, SE1, SE2, SHQ4, SHQ4/A, SME0, SME0/A, SMX2, SXE4, SXE4/A, SXE8, SXQ4, SXQ4/A	
	90741-805-000	KEY, 7X7X33.....	1	1	-	-	1	----- SE, SE/A, SE1, SE2, SHQ4, SHQ4/A, SMX2, SXE4, SXE4/A, SXE8, SXQ4, SXQ4/A	
11	96100-62070-00	BEARING, RADIAL BALL, 6207...	1	-	1	-	-		
	91001-ZF6-013	BEARING, RADIAL BALL, 6207SH...	-	1	-	1	1		
12	13310-ZF6-D42	CRANKSHAFT COMP.	-	-	-	1	-	----- EDE2, EDE2/A, EDN2, EDN2/A, EDS6, EDS6/A, EDT6, EDT6/A	



E-8

PISTON

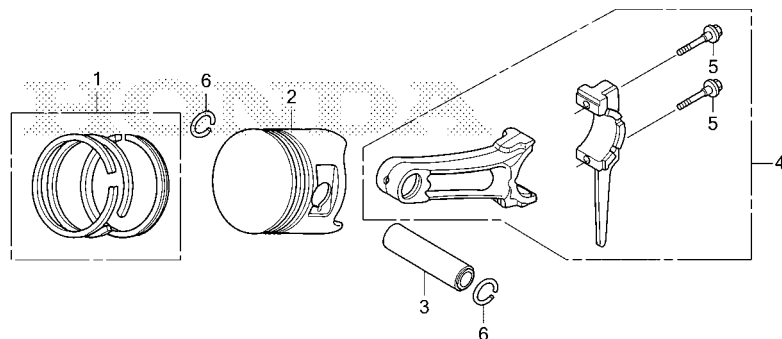

Z8T0E0800A

Ref. No. L.O.N. (Relative ref. Number) Description F.R.T.

Ref. No.	Part No.	Description	Reqd. QTY					Serial No.	Parts catalogue code
			GX 340 UT1	GX 340 UT2	GX 340 RT1	GX 340 RT2	GX 340 UT2X		
1	13010-Z5L-004	RING SET, PISTON(STD.)(TPR) ..	1	-	1	-	-		
	13011-Z5L-004	RING SET, PISTON(0.25)(TPR) ..	(1)	-	(1)	-	-		
	13012-Z5L-004	RING SET, PISTON(0.50)(TPR) ..	(1)	-	(1)	-	-		
	13013-Z5L-004	RING SET, PISTON(0.75)(TPR) ..	(1)	-	(1)	-	-		
	13010-Z5R-004	RING SET, PISTON(STD.)(TEIKOKU)	-	1	-	1	1		
	13010-Z5T-003	RING SET, PISTON(STD.)(RIKEN)	-	1	-	1	1		
	13011-Z5R-004	RING SET, PISTON(0.25)(TEIKOKU)	-	(1)	-	(1)	-	LX2, LXE4, LXU, QAG, QDW9, QHQ4, QNB2, QXB9, QXE6, QXE8, QXU, QXU/A, QZA2, QZAV, QZN2, QZX4, SHQ4, SHQ4/A, SMX2, SXE8, VA2, VDE2, VWS, VX16, VX16/A, VXB7, VXB9, VXE2, VXE2/A, VXE9	
	13011-Z5T-003	RING SET, PISTON(0.25)(RIKEN)	-	(1)	-	(1)	-	LX2, LXE4, LXU, QAG, QDW9, QHQ4, QNB2, QXB9, QXE6, QXE8, QXU, QXU/A, QZA2, QZAV, QZN2, QZX4, SHQ4, SHQ4/A, SMX2, SXE8, VA2, VDE2, VWS, VX16, VX16/A, VXB7, VXB9, VXE2, VXE2/A, VXE9	
	13012-Z5R-004	RING SET, PISTON(0.50)(TEIKOKU)	-	(1)	-	(1)	-	LX2, LXE4, LXU, QAG, QDW9, QHQ4, QNB2, QXB9, QXE6, QXE8, QXU, QXU/A, QZA2, QZAV, QZN2, QZX4, SHQ4, SHQ4/A, SMX2, SXE8, VA2, VDE2, VWS, VX16, VX16/A, VXB7, VXB9, VXE2, VXE2/A, VXE9	
	13012-Z5T-003	RING SET, PISTON(0.50)(RIKEN)	-	(1)	-	(1)	-	LX2, LXE4, LXU, QAG, QDW9, QHQ4, QNB2, QXB9, QXE6, QXE8, QXU, QXU/A, QZA2, QZAV, QZN2, QZX4, SHQ4, SHQ4/A, SMX2, SXE8, VA2, VDE2, VWS, VX16, VX16/A, VXB7, VXB9, VXE2, VXE2/A, VXE9	
	13013-Z5R-004	RING SET, PISTON(0.75)(TEIKOKU)	-	(1)	-	(1)	-	LX2, LXE4, LXU, QAG, QDW9, QHQ4, QNB2, QXB9, QXE6, QXE8, QXU, QXU/A, QZA2, QZAV, QZN2, QZX4, SHQ4, SHQ4/A, SMX2, SXE8, VA2, VDE2, VWS, VX16, VX16/A, VXB7, VXB9, VXE2, VXE2/A, VXE9	
	13013-Z5T-003	RING SET, PISTON(0.75)(RIKEN)	-	(1)	-	(1)	-	LX2, LXE4, LXU, QAG, QDW9, QHQ4, QNB2, QXB9, QXE6, QXE8, QXU, QXU/A, QZA2, QZAV, QZN2, QZX4, SHQ4, SHQ4/A, SMX2, SXE8, VA2, VDE2, VWS, VX16, VX16/A, VXB7, VXB9, VXE2, VXE2/A, VXE9	
2	13101-ZE3-W01	PISTON(STD.)	1	-	1	-	-		

E-8

PISTON

Ref. No.	Part No.	Description	Reqd. QTY					Serial No.	Parts catalogue code
			GX 340 UT1	GX 340 UT2	GX 340 RT1	GX 340 RT2	GX 340 UT2X		
(2)	13102-ZE3-W01	PISTON(0.25)	(1)	-	(1)	-	-		
	13103-ZE3-W01	PISTON(0.50)	(1)	-	(1)	-	-		
	13104-ZE3-W01	PISTON(0.75)	(1)	-	(1)	-	-		
	13101-Z1C-900	PISTON(STD.)	-	1	-	1	-	EDE2/A, EDN2/A, EDS6/A, EDT6/A, HA2/A, HX26/A, LXQ4/A, PKT2/A, PKX2/A, QA2/A, QAE2/A, QAE6/A, QAH2/A, QAP2/A, QE/A, QHB4/A, QKA4/A, QMT2/A, QNE2/A, QNR2/A, QWC/A, QXB7/A, QXE4/A, QXQ4/A, QXU/A, SE/A, SE1, SE2, SHQ4/A, SME0/A, SXE4/A, SXQ4/A, VWC/A, VWE/A, VWE2/A, VWS1, VWS1/A, VX16/A, VX8/A, VXE2/A, VXE8/A, LX2, LXE4, LXU, QAG, QDW9, QHQ4, QNB2, QXB9, QXE6, QXE8, QXU, QXU/A, QZA2, QZAV, QZN2, QZX4, SHQ4, SHQ4/A, SMX2, SXE8, VA2, VDE2, VWS, VX16, VX16/A, VXB7, VXB9, VXE2, VXE2/A, VXE9	
	13102-Z5T-800	PISTON(0.25)	-	(1)	-	(1)	-	LX2, LXE4, LXU, QAG, QDW9, QHQ4, QNB2, QXB9, QXE6, QXE8, QXU, QXU/A, QZA2, QZAV, QZN2, QZX4, SHQ4, SHQ4/A, SMX2, SXE8, VA2, VDE2, VWS, VX16, VX16/A, VXB7, VXB9, VXE2, VXE2/A, VXE9	
	13103-Z5T-800	PISTON(0.50)	-	(1)	-	(1)	-	LX2, LXE4, LXU, QAG, QDW9, QHQ4, QNB2, QXB9, QXE6, QXE8, QXU, QXU/A, QZA2, QZAV, QZN2, QZX4, SHQ4, SHQ4/A, SMX2, SXE8, VA2, VDE2, VWS, VX16, VX16/A, VXB7, VXB9, VXE2, VXE2/A, VXE9	
	13104-Z5T-800	PISTON(0.75)	-	(1)	-	(1)	-	LX2, LXE4, LXU, QAG, QDW9, QHQ4, QNB2, QXB9, QXE6, QXE8, QXU, QXU/A, QZA2, QZAV, QZN2, QZX4, SHQ4, SHQ4/A, SMX2, SXE8, VA2, VDE2, VWS, VX16, VX16/A, VXB7, VXB9, VXE2, VXE2/A, VXE9	
	13101-Z5T-800	PISTON(STD.)	-	1	-	-	-	1081996 HA2, HX26, LX2, LXE4, LXQ4, LXU, PKT2, PKX2, QA2, QAE2, QAE6, QAG, QAH2, QAP2, QDW9, QE, QHB4, QHQ4, QKA4, QMT2, QNE2, QNR2, QWC, QXB7, QXB9, QXC9, QXE4, QXE6, QXE8, QXQ4, QXU, QZA2, QZAV, QZN2, QZX4, SE, SHQ4, SME0, SMX2, SXE4, SXE8, SXQ4, VA2, VX16, VX8, VXB7, VXB9, VXE2, VXE8, VXE9	
	13101-Z1C-900	-	1	-	-	-	1081997 HA2, HX26, LX2, LXE4, LXQ4, LXU, PKT2, PKX2, QA2, QAE2, QAE6, QAG, QAH2, QAP2, QDW9, QE, QHB4, QHQ4, QKA4, QMT2, QNE2, QNR2, QWC, QXB7, QXB9, QXC9, QXE4, QXE6, QXE8, QXQ4, QXU, QZA2, QZAV, QZN2, QZX4, SE, SHQ4, SME0, SMX2, SXE4, SXE8, SXQ4, VA2, VX16, VX8, VXB7, VXB9, VXE2, VXE8, VXE9	
	13101-Z5T-800	-	-	-	1	-	1082092 EDE2, EDN2, EDS6, EDT6, QNB2, VDE2, VWC, VWE, VWE2, VWS	
	13101-Z1C-900	-	-	-	1	-	1082093 EDE2, EDN2, EDS6, EDT6, QNB2, VDE2, VWC, VWE, VWE2, VWS	
	3 13111-ZF6-000	PIN, PISTON	1	-	1	-	-		
	13111-Z5T-000	-	1	-	1	1		
4	13200-Z1C-000	ROD ASSY., CONNECTING(STD.) ..	1	-	1	-	-		
	13200-ZE3-315	ROD ASSY., CONNECTING (0.25 UNDER SIZE) ..	(1)	-	(1)	-	-		
	13200-Z1C-900	ROD ASSY., CONNECTING(STD.) ..	-	1	-	1	-	EDE2/A, EDN2/A, EDS6/A, EDT6/A, HA2/A, HX26/A, LXQ4/A, PKT2/A, PKX2/A, QA2/A, QAE2/A, QAE6/A, QAH2/A, QAP2/A, QE/A, QHB4/A, QKA4/A, QMT2/A, QNE2/A, QNR2/A, QWC/A, QXB7/A, QXE4/A, QXQ4/A, QXU/A, SE/A, SE1, SE2, SHQ4/A, SME0/A, SXE4/A, SXQ4/A, VWC/A, VWE/A, VWE2/A, VWS1, VWS1/A, VX16/A, VX8/A, VXE2/A, VXE8/A, LX2, LXE4, LXU, QAG, QDW9, QHQ4, QNB2, QXB9, QXE6, QXE8, QXU, QXU/A, QZA2, QZAV, QZN2, QZX4, SHQ4, SHQ4/A, SMX2, SXE8, VA2, VDE2, VWS, VX16, VX16/A, VXB7, VXB9, VXE2, VXE2/A, VXE9	
	13200-Z1C-305	ROD ASSY., CONNECTING (0.25 UNDER SIZE) ..	-	(1)	-	(1)	-	LX2, LXE4, LXU, QAG, QDW9, QHQ4, QNB2, QXB9, QXE6, QXE8, QXU, QXU/A, QZA2, QZAV, QZN2, QZX4, SHQ4, SHQ4/A, SMX2, SXE8, VA2, VDE2, VWS, VX16, VX16/A, VXB7, VXB9, VXE2, VXE2/A, VXE9	
	13200-Z1C-000	ROD ASSY., CONNECTING(STD.) ..	-	1	-	-	-	1081996 HA2, HX26, LX2, LXE4, LXQ4, LXU, PKT2, PKX2, QA2, QAE2, QAE6, QAG, QAH2, QAP2, QDW9, QE, QHB4, QHQ4, QKA4, QMT2, QNE2, QNR2, QWC, QXB7, QXB9, QXC9, QXE4, QXE6, QXE8, QXQ4, QXU, QZA2, QZAV, QZN2, QZX4, SE, SHQ4, SME0, SMX2, SXE4, SXE8, SXQ4, VA2, VX16, VX8, VXB7, VXB9, VXE2, VXE8, VXE9	
	13200-Z1C-900	-	1	-	-	-	1081997 HA2, HX26, LX2, LXE4, LXQ4, LXU, PKT2, PKX2, QA2, QAE2, QAE6, QAG, QAH2, QAP2, QDW9, QE, QHB4, QHQ4, QKA4, QMT2, QNE2, QNR2, QWC, QXB7, QXB9, QXC9, QXE4, QXE6, QXE8, QXQ4, QXU, QZA2, QZAV, QZN2, QZX4, SE, SHQ4, SME0, SMX2, SXE4, SXE8, SXQ4, VA2, VX16, VX8, VXB7, VXB9, VXE2, VXE8, VXE9	
	13200-Z1C-000	-	-	-	1	-	1082092 EDE2, EDN2, EDS6, EDT6, QNB2, VDE2, VWC, VWE, VWE2, VWS	
	13200-Z1C-900	-	-	-	1	-	1082093 EDE2, EDN2, EDS6, EDT6, QNB2, VDE2, VWC, VWE, VWE2, VWS	
	5 90001-ZE8-000	BOLT, CONNECTING ROD	2	2	2	2	2		
	6 90601-ZE3-000	CLIP, PISTON PIN, 20MM	2	2	2	2	2		



E-9

CAMSHAFT

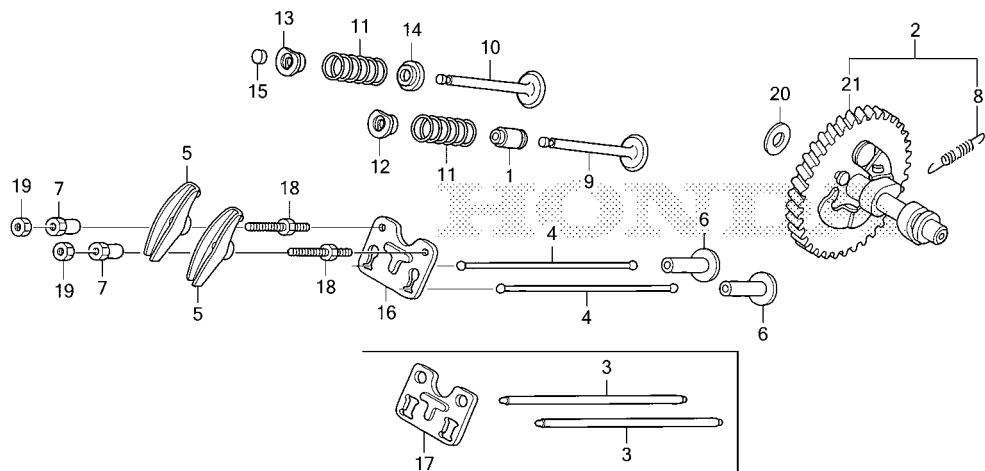

Z8T0E0900D

Ref. L.O.N. (Relative ref. Number) F.R.T.
No. Description

Ref. No.	Part No.	Description	Reqd. QTY					Serial No.	Parts catalogue code
			GX 340 UT1	GX 340 UT2	GX 340 RT1	GX 340 RT2	GX 340 UT2X		
1	12209-ZE8-003	SEAL, VALVE STEM.....	1	1	1	1	1		
2	14100-ZE3-020	CAMSHAFT ASSY.....	1	-	1	-	-	HA2, HX26, LX2, LXE4, LXE8, LXQ4, LXU, PKT2, QA2, QA26, QAE2, QAE6, QAH2, QAP2, QDW9, QE, QHB4, QHQ4, QKA4, QNB2, QNE2, QNR2, QNR6, QXC4, QXC6, QXC9, QXE4, QXE6, QXE8, QXQ4, QXU, SE, SHQ4, SME0, SXE4, SXE8, SXQ4, VA2, VAD2, VC2, VDE2, VW12, VWC, VWE, VWE2, VX16, VX8, VXE2, VXE8, QXB7, VXB7, VXE7, QXB9, VXB9, VXE9, 1014305, 1058573	
	14100-ZK3-870	1	-	-	-	-		
	14100-ZK3-880	1	-	-	-	-		
	14100-Z5K-820	-	1	-	-	-	1014305	
	14100-Z5K-810	CAMSHAFT ASSY.(MOLDING CAM) ..	-	1	-	-	-	1058573	
			-	-	-	1	-	1000707	
3	14410-ZK6-880	ROD COMP., PUSH.....	2	2	-	-	-	1059965	
4	14410-Z1C-000	ROD, PUSH.....	2	2	2	2	2	EDE2, EDN2, EDS6, EDT6, QNB2, VDE2, VWC, VWE, VWE2, VWS, QXB9, VXB9, VXE9, EDE2, EDE2/A, EDN2, EDN2/A, EDS6, EDS6/A, EDT6, EDT6/A, HA2, HA2/A, HX26, HX26/A, LX2, LXE4, LXE8, LXQ4, LXQ4/A, LXU, PKT2, PKT2/A, PKX2, PKX2/A, QA2, QA2/A, QA26, QAE2, QAE2/A, QAE6, QAE6/A, QAG, QAH2, QAH2/A, QAP2, QAP2/A, QDW9, QE, QE/A, QHB4, QHB4/A, QHQ4, QKA4, QKA4/A, QMT2, QMT2/A, QNB2, QNE2, QNE2/A, QNR2, QNR2/A, QNR6, QWC, QWC/A, QXB7, QXB7/A, QXC4, QXC6, QXC9, QXE4, QXE4/A, QXE6, QXE8, QXQ4, QXQ4/A, QXU, QXU/A, QZA2, QZAV, QZN2, QZX4, SE, SE/A, SE1, SE2, SHQ4, SHQ4/A, SME0, SME0/A, SMX2, SXE4, SXE4/A, SXE8, SXQ4, SXQ4/A, VA2, VAD2, VC2, VDE2, VW12, VWC, VWC/A, VWE, VWE/A, VWE2, VWE2/A, VWS, VWS1, VWS1/A, VX16, VX16/A, VX8, VX8/A, VXB7, VXE2, VXE2/A, VXE7, VXE8, VXE8/A	
5	14431-ZE2-010	ARM, VALVE ROCKER.....	2	2	2	2	2		
6	14441-ZE2-000	LIFTER, VALVE.....	2	2	2	2	2		

E-9

CAMSHAFT

Ref. No.	Part No.	Description	Reqd. QTY					Serial No.	Parts catalogue code
			GX 340 UT1	GX 340 UT2	GX 340 RT1	GX 340 RT2	GX 340 UT2X		
7	14451-ZE1-013 14451-Z4M-000	PIVOT, ROCKER ARM	2	-	2	-	-	-	EDE2/A, EDN2/A, EDS6/A, EDT6/A, HA2/A, HX26/A, LXQ4/A, PKT2/A, PKX2/A, QA2/A, QAE2/A, QAE6/A, QAH2/A, QAP2/A, QE/A, QHB4/A, QKA4/A, QMT2/A, QNE2/A, QNR2/A, QWC/A, QXB7/A, QXE4/A, QXQ4/A, QXU/A, SE/A, SE1, SE2, SHQ4/A, SME0/A, SXE4/A, SXQ4/A, VWC/A, VWE/A, VWE2/A, VWS1, VWS1/A, VX16/A, VX8/A, VXE2/A, VXE8/A, VXE9
	14451-ZE1-013	-	2	-	-	-	-	QAG, QZX4, VXE9
	14451-Z4M-000	-	2	-	-	1113229	-	1113229 HA2, HX26, LX2, LXE4, LXQ4, LXU, PKT2, PKX2, QA2, QAE2, QAE6, QAH2, QAP2, QDW9, QE, QHB4, QHQ4, QKA4, QMT2, QNE2, QNR2, QWC, QXB7, QXB9, QXC9, QXE4, QXE6, QXE8, QXQ4, QXU, QZA2, QZAV, QZN2, SE, SHQ4, SME0, SMX2, SXE4, SXE8, SXQ4, VA2, VX16, VX8, VXB7, VXB9, VXE2, VXE8
	14451-ZE1-013	-	-	-	2	-	-	HA2, HX26, LX2, LXE4, LXQ4, LXU, PKT2, PKX2, QA2, QAE2, QAE6, QAH2, QAP2, QDW9, QE, QHB4, QHQ4, QKA4, QMT2, QNE2, QNR2, QWC, QXB7, QXB9, QXC9, QXE4, QXE6, QXE8, QXQ4, QXU, QZA2, QZAV, QZN2, SE, SHQ4, SME0, SMX2, SXE4, SXE8, SXQ4, VA2, VX16, VX8, VXB7, VXB9, VXE2, VXE8
	14451-Z4M-000	-	-	-	2	-	1113325	1113325 EDE2, EDN2, EDS6, EDT6, VDE2, VWC, VWE, VWE2, VWS
	14451-Z4M-000	-	-	-	2	-	1113326	1113326 EDE2, EDN2, EDS6, EDT6, VDE2, VWC, VWE, VWE2, VWS
8	14568-ZE1-000	SPRING, WEIGHT RETURN	1	-	1	-	-	-	QNB2
		-	1	-	-	-	-	1014305 QXB7, QXB9, VXB7, VXB9, VXE9
		-	1	-	-	-	-	1058573 HA2, HX26, LX2, LXE4, LXQ4, LXU, PKT2, PKX2, QA2, QAE2, QAE6, QAG, QAH2, QAP2, QDW9, QE, QHB4, QHQ4, QKA4, QMT2, QNE2, QNR2, QWC, QXC9, QXE4, QXE6, QXE8, QXQ4, QXU, QZA2, QZAV, QZN2, QZX4, SE, SHQ4, SME0, SMX2, SXE4, SXE8, SXQ4, VA2, VX16, VX8, VXE2, VXE8
		-	-	-	1	-	1000707	1059965 EDE2, EDN2, EDS6, EDT6, QNB2, VDE2, VWC, VWE, VWE2, VWS
9	14711-ZE3-000 14711-Z5T-900	VALVE, IN.	1	-	1	-	-	-	EDE2/A, EDN2/A, EDS6/A, EDT6/A, HA2/A, HX26/A, LXQ4/A, PKT2/A, PKX2/A, QA2/A, QAE2/A, QAE6/A, QAH2/A, QAP2/A, QE/A, QHB4/A, QKA4/A, QMT2/A, QNE2/A, QNR2/A, QWC/A, QXB7/A, QXE4/A, QXQ4/A, QXU/A, SE/A, SE1, SE2, SHQ4/A, SME0/A, SXE4/A, SXQ4/A, VWC/A, VWE/A, VWE2/A, VWS1, VWS1/A, VX16/A, VX8/A, VXE2/A, VXE8/A, VXE9
	14711-Z5T-000	-	1	-	-	-	1074556	1074556 HA2, HX26, LX2, LXE4, LXQ4, LXU, PKT2, PKX2, QA2, QAE2, QAE6, QAG, QAH2, QAP2, QDW9, QE, QHB4, QHQ4, QKA4, QMT2, QNE2, QNR2, QWC, QXB7, QXB9, QXC9, QXE4, QXE6, QXE8, QXQ4, QXU, QZA2, QZAV, QZN2, QZX4, SE, SHQ4, SME0, SMX2, SXE4, SXE8, SXQ4, VA2, VX16, VX8, VXB7, VXB9, VXE2, VXE8, VXE9
	14711-Z5T-900	-	1	-	-	-	1074557	1074557 HA2, HX26, LX2, LXE4, LXQ4, LXU, PKT2, PKX2, QA2, QAE2, QAE6, QAG, QAH2, QAP2, QDW9, QE, QHB4, QHQ4, QKA4, QMT2, QNE2, QNR2, QWC, QXB7, QXB9, QXC9, QXE4, QXE6, QXE8, QXQ4, QXU, QZA2, QZAV, QZN2, QZX4, SE, SHQ4, SME0, SMX2, SXE4, SXE8, SXQ4, VA2, VX16, VX8, VXB7, VXB9, VXE2, VXE8, VXE9
	14711-Z5T-000	-	-	-	1	-	1075630	1075630 EDE2, EDN2, EDS6, EDT6, QNB2, VDE2, VWC, VWE, VWE2, VWS
	14711-Z5T-900	-	-	-	1	-	1075631	1075631 EDE2, EDN2, EDS6, EDT6, QNB2, VDE2, VWC, VWE, VWE2, VWS
10	14721-ZE3-000 14721-Z5T-900	VALVE, EX.	1	-	1	-	-	-	EDE2/A, EDN2/A, EDS6/A, EDT6/A, HA2/A, HX26/A, LXQ4/A, PKT2/A, PKX2/A, QA2/A, QAE2/A, QAE6/A, QAH2/A, QAP2/A, QE/A, QHB4/A, QKA4/A, QMT2/A, QNE2/A, QNR2/A, QWC/A, QXB7/A, QXE4/A, QXQ4/A, QXU/A, SE/A, SE1, SE2, SHQ4/A, SME0/A, SXE4/A, SXQ4/A, VWC/A, VWE/A, VWE2/A, VWS1, VWS1/A, VX16/A, VX8/A, VXE2/A, VXE8/A, VXE9
	14721-Z5T-000	-	1	-	-	-	1074556	1074556 HA2, HX26, LX2, LXE4, LXQ4, LXU, PKT2, PKX2, QA2, QAE2, QAE6, QAG, QAH2, QAP2, QDW9, QE, QHB4, QHQ4, QKA4, QMT2, QNE2, QNR2, QWC, QXB7, QXB9, QXC9, QXE4, QXE6, QXE8, QXQ4, QXU, QZA2, QZAV, QZN2, QZX4, SE, SHQ4, SME0, SMX2, SXE4, SXE8, SXQ4, VA2, VX16, VX8, VXB7, VXB9, VXE2, VXE8, VXE9



E-9

CAMSHAFT

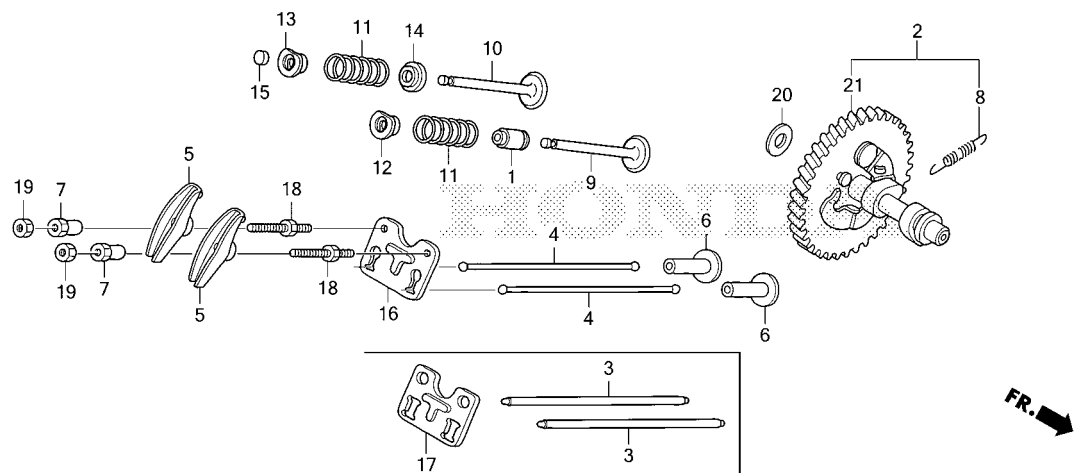

Z8T0E0900D

Ref. No.	Part No.	Description	Reqd. QTY					Serial No.	Parts catalogue code
			GX 340 UT1	GX 340 UT2	GX 340 RT1	GX 340 RT2	GX 340 UT2X		
10)	14721-Z5T-900	VALVE, EX.	-	1	-	-	-	1074557 -----	HA2, HX26, LX2, LXE4, LXQ4, LXU, PKT2, PKX2, QA2, QAE2, QAE6, QAG QAH2, QAP2, QDW9, QE, QHB4, QHQ4, QKA4, QMT2, QNE2, QNR2, QWC, QXB7 QXB9, QXC9, QXE4, QXE6, QXE8, QXQ4, QXU, QZA2, QZAV, QZN2, QZX4, SE SHQ4, SME0, SMX2, SXE4, SXE8, SXQ4, VA2, VX16, VX8, VXB7, VXB9, VXE2 VXE8, VXE9
	14721-Z5T-000	-	-	-	1	-	----- 1075630	EDE2, EDN2, EDS6, EDT6, QNB2, VDE2, VVC, VVE, VWE2, VWS
	14721-Z5T-900	-	-	-	1	-	----- 1075631	EDE2, EDN2, EDS6, EDT6, QNB2, VDE2, VVC, VVE, VWE2, VWS
			-	-	-	-	1		
11	14751-Z1C-000	SPRING, VALVE	2	2	2	2	2		
12	14771-Z8S-000	RETAINER, IN. VALVE SPRING...	1	1	1	1	1		
13	14773-Z8S-000	RETAINER, EX. VALVE SPRING...	1	-	1	-	-		
	14771-Z8S-000	RETAINER, IN. VALVE SPRING... (EXHAUST SIDE)	-	1	-	1	1		
14	14775-ZE2-010	SEAT, VALVE SPRING	1	1	1	1	1		
15	14781-ZE2-000	ROTATOR, VALVE	1	-	1	-	-		
16	14791-ZE2-010	GUIDE, PUSH ROD	1	-	-	-	-	----- 1000009	HA2, HX26, LX2, LXE4, LXE8, LXQ4, LXU, PKT2, QA2, QA26, QAE2, QAE6 QAG, QAH2, QAP2, QDW9, QE, QHB4, QHQ4, QKA4, QNE2, QNR2, QNR6, QXB7 QXC4, QXC6, QXC9, QXE4, QXE6, QXE8, QXQ4, QXU, SE, SHQ4, SME0, SXE4 SXE8, SXQ4, VA2, VX16, VX8, VXB7, VXE2, VXE7, VXE8

E-9

CAMSHAFT

Ref. No.	Part No.	Description	Reqd. QTY					Serial No.	Parts catalogue code
			GX 340 UT1	GX 340 UT2	GX 340 RT1	GX 340 RT2	GX 340 UT2X		
16)	14791-Z1D-000	GUIDE, PUSH ROD.....	1	-	-	-	-	1000010	----- HA2, HX26, LX2, LXE4, LXE8, LXQ4, LXU, PKT2, QA2, QA26, QAE2, QAE6 QAG, QAH2, QAP2, QDW9, QE, QHB4, QHQ4, QKA4, QNE2, QNR2, QNR6, QXB7 QXC4, QXC6, QXC9, QXE4, QXE6, QXE8, QXQ4, QXU, SE, SHQ4, SME0, SXE4 SXE8, SXQ4, VA2, VX16, VX8, VXB7, VXE2, VXE7, VXE8
			-	1	-	1	1	-----	----- EDE2, EDE2/A, EDN2, EDN2/A, EDS6, EDS6/A, EDT6, EDT6/A, HA2, HA2/A HX26, HX26/A, LX2, LXE4, LXQ4, LXQ4/A, LXU, PKT2, PKT2/A, PKX2 PKX2/A, QA2, QA2/A, QAE2, QAE2/A, QAE6, QAE6/A, QAG, QAH2, QAH2/A QAP2, QAP2/A, QDW9, QE, QE/A, QHB4, QHB4/A, QHQ4, QKA4, QKA4/A QMT2, QMT2/A, QNB2, QNE2, QNE2/A, QNR2, QNR2/A, QWC, QWC/A, QXB7 QXB7/A, QXC9, QXE4, QXE4/A, QXE6, QXE8, QXQ4, QXQ4/A, QXU, QXU/A QZA2, QZAV, QZN2, QZX4, SE, SE/A, SE1, SE2, SHQ4, SHQ4/A, SME0 SME0/A, SMX2, SXE4, SXE4/A, SXE8, SXQ4, SXQ4/A, VA2, VDE2, VWC VWC/A, VWE, VWE/A, VWE2, VWE2/A, VWS, VWS1, VWS1/A, VX16, VX16/A VX8, VX8/A, VXB7, VXE2, VXE2/A, VXE8, VXE8/A
	14791-ZE2-010	-	-	1	-	-	-----	1000281
	14791-Z1D-000	-	-	1	-	-	-----	1000282
17	14791-ZK6-880	GUIDE, PUSH ROD.....	1	1	-	-	-	-----	----- QXB9, VXB9, VXE9
18	90012-ZE0-010	BOLT, PIVOT, 8MM.....	2	2	2	2	2		
19	90206-ZE1-000	NUT, PIVOT ADJUSTING.....	2	2	2	2	2		
20	90413-ZK6-880	WASHER, THRUST, 16.1MM.....	1	-	-	-	-	-----	----- QXB9, VXB9, VXE9
			-	1	-	-	1	-----	----- QXB7, QXB7/A, QXB9, VXB7, VXB9, VXE9
21	14100-Z5K-910	CAMSHAFT COMP.(STD.) (PRESS FIT CAM)	-	1	-	1	-	-----	----- EDE2, EDE2/A, EDN2, EDN2/A, EDS6, EDS6/A, EDT6, EDT6/A, HA2/A HX26/A, LXQ4/A, PKT2/A, PKX2, PKX2/A, QA2/A, QAE2/A, QAE6/A QAH2/A, QAP2/A, QE/A, QHB4/A, QKA4/A, QMT2, QMT2/A, QNE2/A QNR2/A, QWC, QWC/A, QXE4/A, QXQ4/A, QXU/A, SE/A, SE1, SE2, SHQ4/A SME0/A, SMX2, SXE4/A, SXQ4/A, VWC/A, VWE/A, VWE2/A, VWS, VWS1 VWS1/A, VX16/A, VX8/A, VXE2/A, VXE8/A
			-	1	-	1	-	1013458	----- HA2, HX26, LX2, LXE4, LXQ4, LXU, PKT2, QA2, QAE2, QAE6, QAG, QAH2 QAP2, QDW9, QE, QHB4, QHQ4, QKA4, QNB2, QNE2, QNR2, QXC9, QXE4, QXE6 QXE8, QXQ4, QXU, QZA2, QZAV, QZN2, QZX4, SE, SHQ4, SME0, SXE4, SXE8 SXQ4, VA2, VDE2, VWC, VWE, VWE2, VX16, VX8, VXE2, VXE8
	14100-Z5K-920	CAMSHAFT COMP.(LOW NOISE) (PRESS FIT CAM)	-	1	-	-	-	-----	----- QXB7/A
			-	1	-	-	-	1014306	----- QXB7, QXB9, VXB7, VXB9, VXE9
	14100-Z5K-910	CAMSHAFT COMP.(STD.) (PRESS FIT CAM)	-	-	-	-	1	-----	----- HA2, HX26, LXQ4, PKT2, PKX2, QA2, QAE2, QAE6, QAH2, QAP2, QE, QHB4 QKA4, QMT2, QNE2, QNR2, QWC, QXE4, QXQ4, SE, SE1, SE2, SME0, SXE4 SXQ4, VX8, VXE8
	14100-Z5K-920	CAMSHAFT COMP.(LOW NOISE) (PRESS FIT CAM)	-	-	-	-	1	-----	----- QXB7



E-11

RECOIL STARTER(1)

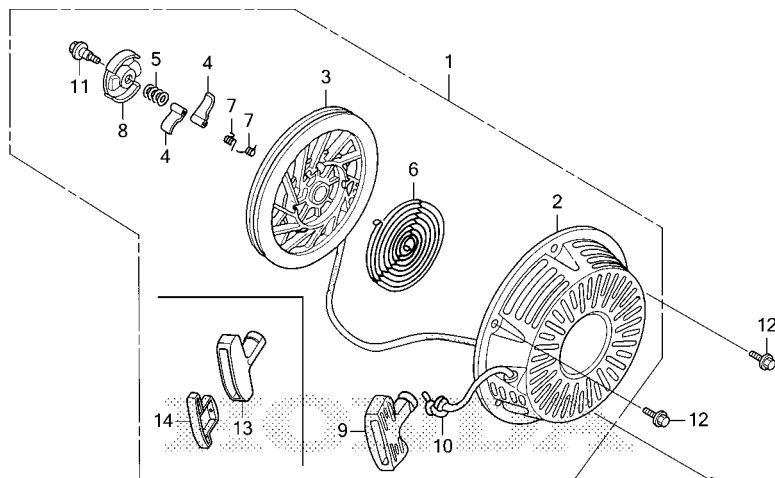

Ref. L.O.N. (Relative ref. Number) F.R.T.
No. Description

Ref. No.	Part No.	Description	Reqd. QTY					Serial No.	Parts catalogue code
			GX 340 UT1	GX 340 UT2	GX 340 RT1	GX 340 RT2	GX 340 UT2X		
1	28400-ZE3-W01ZP	STARTER ASSY., RECOIL *R280*.....POWER RED	1	-	1	-	-	-----	HA2, HX26, LX2, LXE4, LXE8, LXQ4, LXU, PKT2, QA2, QA26, QAE2, QAE6, QAG, QAH2, QAP2, QE, QHB4, QHQ4, QKA4, QNB2, QNE2, QNR2, QNR6, QXB7, QXB9, QXC4, QXC6, QXC9, QXE4, QXE6, QXE8, QXQ4, QXU, SE, SHQ4, SME0, SXE4, SXE8, SXQ4, VA2, VAD2, VC2, VDE2, VW12, VX16, VX8, VXB7, VXB9, VXE2, VXE7, VXE8, VXE9
	28400-ZE3-W01ZB	*NH1*.....BLACK	1	-	1	-	-	-----	PKT2, QA2, QAE2, QAP2, QDW9, QKA4, QNR2, QXC9, QXQ4, QXU, SHQ4, SME0, VC2
	28400-ZE3-W01ZH	*NH105*....MAT BLACK(#15-#20)	1	-	1	-	-	-----	VDE2, VW12, VWC, VWE, VWE2, VXB7, VXB9, VXE2, VXE7, VXE9
	28400-ZE3-W02ZH	*NH105*....MAT BLACK(#15-#20)	1	-	1	-	1023043	-----	VDE2, VW12, VWC, VWE, VWE2, VXB7, VXB9, VXE2, VXE7, VXE9
	28400-ZE3-W01ZE	*T41*...BARTELL BLUE METALLIC	1	-	-	-	-	-----	1009283 QA2, QA26
	28400-ZE3-W01ZC	*T34*.....SIMPSON BLUE	1	-	-	-	-	-----	1027171 QA2
	28400-ZE3-W02ZE	*T41*...BARTELL BLUE METALLIC	1	-	-	-	1009284	-----	QA2, QA26
	28400-ZE3-W02ZC	*T34*.....SIMPSON BLUE	1	-	-	-	1027172	-----	QA2
	28400-Z5T-013ZA	*R280*.....POWER RED	-	1	-	1	-	-----	EDE2, EDE2/A, EDN2, EDN2/A, EDS6, EDS6/A, EDT6, EDT6/A, HA2/A, HX26/A, LXQ4/A, PKT2/A, PKX2/A, QA2/A, QAE2/A, QAE6/A, QAH2/A, QAP2/A, QE/A, QHB4/A, QKA4/A, QMT2/A, QNE2/A, QNR2/A, QXB7/A, QXE4/A, QXQ4/A, QXU/A, SE/A, SE1, SHQ4/A, SME0/A, SXE4/A, SXQ4/A, VWS, VX16/A, VX8/A, VXE2/A, VXE8/A
	28400-Z5T-013ZB	*NH1*.....BLACK	-	1	-	1	-	-----	EDE2, EDE2/A, EDN2, EDN2/A, EDS6, EDS6/A, EDT6, EDT6/A, PKT2/A, PKX2/A, QA2/A, QAE2/A, QAP2/A, QKA4/A, QMT2/A, QNR2/A, QWC, QWC/A, QXQ4/A, QXU/A, SE/A, SE1, SE2, SHQ4/A, SME0/A, VWC/A, VWE/A, VWE2/A, VWS, VWS1, VWS1/A, VXE2/A
	28400-Z5T-305ZB	STARTER ASSY., RECOIL (FOR U.S.A.)							
		NH1.....BLACK	-	1	-	1	-	-----	EDE2, EDN2, EDS6, EDT6, PKX2, QMT2, QWC, SMX2, VWS
	28400-Z5T-305ZA	*R280*.....POWER RED	-	1	-	1	-	-----	EDE2, EDN2, EDS6, EDT6, PKX2, QMT2, SMX2, VWS

E-11

RECOIL STARTER(1)

Ref. No.	Part No.	Description	Reqd. QTY					Serial No.	Parts catalogue code
			GX 340 UT1	GX 340 UT2	GX 340 RT1	GX 340 RT2	GX 340 UT2X		
(1)	28400-Z5T-003ZA	STARTER ASSY., RECOIL *R280*.....POWER RED	-	1	-	1	-	1014917	HA2, HX26, LX2, LXE4, LXQ4, LXU, PKT2, QA2, QAE2, QAE6, QAG, QAH2, QAP2, QE, QHB4, QHQ4, QKA4, QNB2, QNE2, QNR2, QXB7, QXB9, QXC9, QXE4, QXE6, QXE8, QXQ4, QXU, SE, SHQ4, SME0, SXE4, SXE8, SXQ4, VA2, VDE2, VX16, VX8, VXB7, VXB9, VXE2, VXE8, VXE9
	28400-Z5T-003ZB	*NH1*.....BLACK	-	1	-	1	-	1014917	PKT2, QA2, QAE2, QAP2, QDW9, QKA4, QNR2, QXC9, QXQ4, QXU, SHQ4, SME0, VDE2, VWC, VWE, VWE2, VXB7, VXB9, VXE2, VXE9
	28400-Z5T-013ZA	*R280*.....POWER RED	-	1	-	1	-	1014918	HA2, HX26, LX2, LXE4, LXQ4, LXU, PKT2, QA2, QAE2, QAE6, QAG, QAH2, QAP2, QE, QHB4, QHQ4, QKA4, QNB2, QNE2, QNR2, QXB7, QXB9, QXC9, QXE4, QXE6, QXE8, QXQ4, QXU, SE, SHQ4, SME0, SXE4, SXE8, SXQ4, VA2, VDE2, VX16, VX8, VXB7, VXB9, VXE2, VXE8, VXE9
	28400-Z5T-013ZB	*NH1*.....BLACK	-	1	-	1	-	1014918	PKT2, QA2, QAE2, QAP2, QDW9, QKA4, QNR2, QXC9, QXQ4, QXU, SHQ4, SME0, VDE2, VWC, VWE, VWE2, VXB7, VXB9, VXE2, VXE9
	28400-Z5T-013ZA	*R280*.....POWER RED	-	-	-	-	1	-	HA2, HX26, LXQ4, PKT2, PKX2, QA2, QAE2, QAE6, QAH2, QAP2, QE, QHB4, QKA4, QMT2, QNE2, QNR2, QXB7, QXE4, QXQ4, SE, SE1, SME0, SXE4, SXQ4, VX8, VXE8
	28400-Z5T-013ZB	*NH1*.....BLACK	-	-	-	-	1	-	PKT2, PKX2, QA2, QAE2, QAP2, QKA4, QMT2, QNR2, QWC, QXQ4, SE, SE1, SE2, SME0
2	28410-ZE3-W01ZP	CASE COMP., RECOIL STARTER *R280*.....POWER RED	1	1	1	1	1	-	EDE2, EDE2/A, EDN2, EDN2/A, EDS6, EDS6/A, EDT6, EDT6/A, HA2, HA2/A, HX26, HX26/A, LX2, LXE4, LXE8, LXQ4, LXQ4/A, LXU, PKT2, PKT2/A, PKX2, PKX2/A, QA2, QA2/A, QA26, QAE2, QAE2/A, QAE6, QAE6/A, QAG, QAH2, QAH2/A, QAP2, QAP2/A, QE, QE/A, QHB4, QHB4/A, QHQ4, QKA4, QKA4/A, QMT2, QMT2/A, QNB2, QNE2, QNE2/A, QNR2, QNR2/A, QNR6, QXB7, QXB7/A, QXB9, QXC4, QXC6, QXC9, QXE4, QXE4/A, QXE6, QXE8, QXQ4, QXQ4/A, QXU, QXU/A, SE, SE/A, SE1, SHQ4, SHQ4/A, SME0, SME0/A, SMX2, SXE4, SXE4/A, SXE8, SXQ4, SXQ4/A, VA2, VAD2, VC2, VDE2, VW12, VWS, VX16, VX16/A, VX8, VX8/A, VXB7, VXB9, VXE2, VXE2/A, VXE7, VXE8, VXE8/A, VXE9
	28410-ZE3-W01ZB	*NH1*.....BLACK	1	-	1	-	-	-	PKT2, QA2, QAE2, QAP2, QDW9, QKA4, QNR2, QXC9, QXQ4, QXU, SHQ4, SME0, VC2
	28410-ZE3-W01ZH	*NH105*....MAT BLACK(#15-#20)	1	-	1	-	-	-	VDE2, VW12, VWC, VWE, VWE2, VXB7, VXB9, VXE2, VXE7, VXE9
	28410-ZE3-W01ZD	*T34*.....SIMPSON BLUE	1	-	-	-	-	-	QA2
	28410-ZE3-W01ZF	*T41*...BARTELL BLUE METALLIC	1	-	-	-	-	-	QA2, QA26
	28410-ZE3-W01ZB	*NH1*.....BLACK	-	1	-	-	-	-	PKT2, PKT2/A, PKX2, PKX2/A, QA2, QA2/A, QAE2, QAE2/A, QAP2, QAP2/A, QDW9, QKA4, QKA4/A, QMT2, QMT2/A, QNR2, QNR2/A, QWC, QWC/A, QXC9, QXQ4, QXQ4/A, QXU, QXU/A, SE/A, SE1, SE2, SHQ4, SHQ4/A, SME0, SME0/A, SMX2, VXB7, VXB9, VXE2, VXE2/A, VXE9
			-	-	-	1	-	-	EDE2, EDE2/A, EDN2, EDN2/A, EDS6, EDS6/A, EDT6, EDT6/A, VDE2, VWC, VWC/A, VWE, VWE/A, VWE2, VWE2/A, VWS, VWS1, VWS1/A
			-	-	-	-	1	-	PKT2, PKX2, QA2, QAE2, QAP2, QKA4, QMT2, QNR2, QWC, QXQ4, SE, SE1, SE2, SME0
3	28421-ZE3-W01	PULLEY, RECOIL STARTER.....	1	1	1	1	1	-	EDE2, EDE2/A, EDN2, EDN2/A, EDS6, EDS6/A, EDT6, EDT6/A, HA2, HA2/A, HX26, HX26/A, LX2, LXE4, LXE8, LXQ4, LXQ4/A, LXU, PKT2, PKT2/A, PKX2, PKX2/A, QA2, QA2/A, QA26, QAE2, QAE2/A, QAE6, QAE6/A, QAG, QAH2, QAH2/A, QAP2, QAP2/A, QDW9, QE, QE/A, QHB4, QHB4/A, QHQ4, QKA4, QKA4/A, QMT2, QMT2/A, QNB2, QNE2, QNE2/A, QNR2, QNR2/A, QNR6, QWC, QWC/A, QXB7, QXB7/A, QXB9, QXC4, QXC6, QXC9, QXE4, QXE4/A, QXE6, QXE8, QXQ4, QXQ4/A, QXU, QXU/A, SE, SE/A, SE1, SE2, SHQ4, SHQ4/A, SME0, SME0/A, SMX2, SXE4, SXE4/A, SXE8, SXQ4, SXQ4/A, VA2, VAD2, VC2, VDE2, VW12, VWC, VWC/A, VWE, VWE/A, VWE2, VWE2/A, VWS, VWS1, VWS1/A, VX16, VX16/A, VX8, VX8/A, VXB7, VXB9, VXE2, VXE2/A, VXE7, VXE8, VXE8/A, VXE9



E-11

RECOIL STARTER(1)

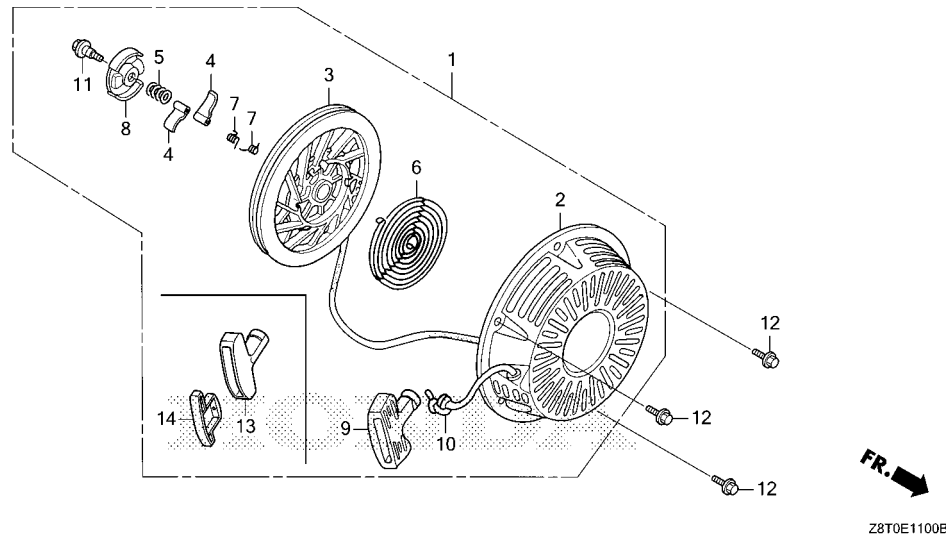

FR. →

Z8T0E1100B

Ref. No.	Part No.	Description	Reqd. QTY					Serial No.	Parts catalogue code
			GX 340 UT1	GX 340 UT2	GX 340 RT1	GX 340 RT2	GX 340 UT2X		
4	28422-ZE2-W01	RATCHET, STARTER.....	2	2	2	2	2	-----	EDE2, EDE2/A, EDN2, EDN2/A, EDS6, EDS6/A, EDT6, EDT6/A, HA2, HA2/A, HX26, HX26/A, LX2, LXE4, LXE8, LXQ4, LXQ4/A, LXU, PKT2, PKT2/A, PKX2, PKX2/A, QA2, QA2/A, QA26, QAE2, QAE2/A, QAE6, QAE6/A, QAG, QAH2, QAH2/A, QAP2, QAP2/A, QDW9, QE, QE/A, QHB4, QHB4/A, QHQ4, QKA4, QKA4/A, QMT2, QMT2/A, QNB2, QNE2, QNE2/A, QNR2, QNR2/A, QNR6, QWC, QWC/A, QXB7, QXB7/A, QXB9, QXC4, QXC6, QXC9, QXE4, QXE4/A, QXE6, QXE8, QXQ4, QXQ4/A, QXU, QXU/A, SE, SE/A, SE1, SE2, SHQ4, SHQ4/A, SME0, SME0/A, SMX2, SXE4, SXE4/A, SXE8, SXQ4, SXQ4/A, VA2, VAD2, VC2, VDE2, VW12, VWC, VWC/A, VWE, VWE/A, VWE2, VWE2/A, VWS, VWS1, VWS1/A, VX16, VX16/A, VX8, VX8/A, VXB7, VXB9, VXE2, VXE2/A, VXE7, VXE8, VXE8/A, VXE9
5	28441-ZE2-W01	SPRING, FRICTION.....	1	1	1	1	1	-----	EDE2, EDE2/A, EDN2, EDN2/A, EDS6, EDS6/A, EDT6, EDT6/A, HA2, HA2/A, HX26, HX26/A, LX2, LXE4, LXE8, LXQ4, LXQ4/A, LXU, PKT2, PKT2/A, PKX2, PKX2/A, QA2, QA2/A, QA26, QAE2, QAE2/A, QAE6, QAE6/A, QAG, QAH2, QAH2/A, QAP2, QAP2/A, QDW9, QE, QE/A, QHB4, QHB4/A, QHQ4, QKA4, QKA4/A, QMT2, QMT2/A, QNB2, QNE2, QNE2/A, QNR2, QNR2/A, QNR6, QWC, QWC/A, QXB7, QXB7/A, QXB9, QXC4, QXC6, QXC9, QXE4, QXE4/A, QXE6, QXE8, QXQ4, QXQ4/A, QXU, QXU/A, SE, SE/A, SE1, SE2, SHQ4, SHQ4/A, SME0, SME0/A, SMX2, SXE4, SXE4/A, SXE8, SXQ4, SXQ4/A, VA2, VAD2, VC2, VDE2, VW12, VWC, VWC/A, VWE, VWE/A, VWE2, VWE2/A, VWS, VWS1, VWS1/A, VX16, VX16/A, VX8, VX8/A, VXB7, VXB9, VXE2, VXE2/A, VXE7, VXE8, VXE8/A, VXE9

2

E-11

RECOIL STARTER(1)

Ref. No.	Part No.	Description	Reqd. QTY					Serial No.	Parts catalogue code
			GX 340 UT1	GX 340 UT2	GX 340 RT1	GX 340 RT2	GX 340 UT2X		
6	28442-ZE2-W01	SPRING, STARTER RETURN	1	1	1	1	1	-----	EDE2, EDE2/A, EDN2, EDN2/A, EDS6, EDS6/A, EDT6, EDT6/A, HA2, HA2/A, HX26, HX26/A, LX2, LXE4, LXE8, LXQ4, LXQ4/A, LXU, PKT2, PKT2/A, PKX2, PKX2/A, QA2, QA2/A, QA26, QAE2, QAE2/A, QAE6, QAE6/A, QAG, QAH2, QAH2/A, QAP2, QAP2/A, QDW9, QE, QE/A, QHB4, QHB4/A, QHQ4, QKA4, QKA4/A, QMT2, QMT2/A, QNB2, QNE2, QNE2/A, QNR2, QNR2/A, QNR6, QWC, QWC/A, QXB7, QXB7/A, QXB9, QXC4, QXC6, QXC9, QXE4, QXE4/A, QXE6, QXE8, QXQ4, QXQ4/A, QXU, QXU/A, SE, SE/A, SE1, SE2, SHQ4, SHQ4/A, SME0, SME0/A, SMX2, SXE4, SXE4/A, SXE8, SXQ4, SXQ4/A, VAD2, VAD2, VC2, VDE2, VW12, VWC, VWC/A, VWE, VWE/A, VWE2, VWE2/A, VWS, VWS1, VWS1/A, VX16, VX16/A, VX8, VX8/A, VXB7, VXB9, VXE2, VXE2/A, VXE7, VXE8, VXE8/A, VXE9
7	28443-ZE2-W01	SPRING, RATCHET	2	2	2	2	2	-----	EDE2, EDE2/A, EDN2, EDN2/A, EDS6, EDS6/A, EDT6, EDT6/A, HA2, HA2/A, HX26, HX26/A, LX2, LXE4, LXE8, LXQ4, LXQ4/A, LXU, PKT2, PKT2/A, PKX2, PKX2/A, QA2, QA2/A, QA26, QAE2, QAE2/A, QAE6, QAE6/A, QAG, QAH2, QAH2/A, QAP2, QAP2/A, QDW9, QE, QE/A, QHB4, QHB4/A, QHQ4, QKA4, QKA4/A, QMT2, QMT2/A, QNB2, QNE2, QNE2/A, QNR2, QNR2/A, QNR6, QWC, QWC/A, QXB7, QXB7/A, QXB9, QXC4, QXC6, QXC9, QXE4, QXE4/A, QXE6, QXE8, QXQ4, QXQ4/A, QXU, QXU/A, SE, SE/A, SE1, SE2, SHQ4, SHQ4/A, SME0, SME0/A, SMX2, SXE4, SXE4/A, SXE8, SXQ4, SXQ4/A, VAD2, VAD2, VC2, VDE2, VW12, VWC, VWC/A, VWE, VWE/A, VWE2, VWE2/A, VWS, VWS1, VWS1/A, VX16, VX16/A, VX8, VX8/A, VXB7, VXB9, VXE2, VXE2/A, VXE7, VXE8, VXE8/A, VXE9
8	28444-ZE2-W01	RETAINER, SPRING	1	1	1	1	1	-----	EDE2, EDE2/A, EDN2, EDN2/A, EDS6, EDS6/A, EDT6, EDT6/A, HA2, HA2/A, HX26, HX26/A, LX2, LXE4, LXE8, LXQ4, LXQ4/A, LXU, PKT2, PKT2/A, PKX2, PKX2/A, QA2, QA2/A, QA26, QAE2, QAE2/A, QAE6, QAE6/A, QAG, QAH2, QAH2/A, QAP2, QAP2/A, QDW9, QE, QE/A, QHB4, QHB4/A, QHQ4, QKA4, QKA4/A, QMT2, QMT2/A, QNB2, QNE2, QNE2/A, QNR2, QNR2/A, QNR6, QWC, QWC/A, QXB7, QXB7/A, QXB9, QXC4, QXC6, QXC9, QXE4, QXE4/A, QXE6, QXE8, QXQ4, QXQ4/A, QXU, QXU/A, SE, SE/A, SE1, SE2, SHQ4, SHQ4/A, SME0, SME0/A, SMX2, SXE4, SXE4/A, SXE8, SXQ4, SXQ4/A, VAD2, VAD2, VC2, VDE2, VW12, VWC, VWC/A, VWE, VWE/A, VWE2, VWE2/A, VWS, VWS1, VWS1/A, VX16, VX16/A, VX8, VX8/A, VXB7, VXB9, VXE2, VXE2/A, VXE7, VXE8, VXE8/A, VXE9
9	28461-ZE2-W02	GRIP, STARTER	1	-	1	-	-	-----	1009283
	28461-ZE2-W03	1	-	1	-	-	-----	1009284
10	28462-ZE3-W01	ROPE, RECOIL STARTER	1	1	1	1	1	-----	EDE2, EDE2/A, EDN2, EDN2/A, EDS6, EDS6/A, EDT6, EDT6/A, HA2, HA2/A, HX26, HX26/A, LX2, LXE4, LXE8, LXQ4, LXQ4/A, LXU, PKT2, PKT2/A, PKX2, PKX2/A, QA2, QA2/A, QA26, QAE2, QAE2/A, QAE6, QAE6/A, QAG, QAH2, QAH2/A, QAP2, QAP2/A, QDW9, QE, QE/A, QHB4, QHB4/A, QHQ4, QKA4, QKA4/A, QMT2, QMT2/A, QNB2, QNE2, QNE2/A, QNR2, QNR2/A, QNR6, QWC, QWC/A, QXB7, QXB7/A, QXB9, QXC4, QXC6, QXC9, QXE4, QXE4/A, QXE6, QXE8, QXQ4, QXQ4/A, QXU, QXU/A, SE, SE/A, SE1, SE2, SHQ4, SHQ4/A, SME0, SME0/A, SMX2, SXE4, SXE4/A, SXE8, SXQ4, SXQ4/A, VAD2, VAD2, VC2, VDE2, VW12, VWC, VWC/A, VWE, VWE/A, VWE2, VWE2/A, VWS, VWS1, VWS1/A, VX16, VX16/A, VX8, VX8/A, VXB7, VXB9, VXE2, VXE2/A, VXE7, VXE8, VXE8/A, VXE9
11	90004-ZE2-W01	SCREW, CENTER	1	1	1	1	1	-----	EDE2, EDE2/A, EDN2, EDN2/A, EDS6, EDS6/A, EDT6, EDT6/A, HA2, HA2/A, HX26, HX26/A, LX2, LXE4, LXE8, LXQ4, LXQ4/A, LXU, PKT2, PKT2/A, PKX2, PKX2/A, QA2, QA2/A, QA26, QAE2, QAE2/A, QAE6, QAE6/A, QAG, QAH2, QAH2/A, QAP2, QAP2/A, QDW9, QE, QE/A, QHB4, QHB4/A, QHQ4, QKA4, QKA4/A, QMT2, QMT2/A, QNB2, QNE2, QNE2/A, QNR2, QNR2/A, QNR6, QWC, QWC/A, QXB7, QXB7/A, QXB9, QXC4, QXC6, QXC9, QXE4, QXE4/A, QXE6, QXE8, QXQ4, QXQ4/A, QXU, QXU/A, SE, SE/A, SE1, SE2, SHQ4, SHQ4/A, SME0, SME0/A, SMX2, SXE4, SXE4/A, SXE8, SXQ4, SXQ4/A, VAD2, VAD2, VC2, VDE2, VW12, VWC, VWC/A, VWE, VWE/A, VWE2, VWE2/A, VWS, VWS1, VWS1/A, VX16, VX16/A, VX8, VX8/A, VXB7, VXB9, VXE2, VXE2/A, VXE7, VXE8, VXE8/A, VXE9



E-11

RECOIL STARTER(1)

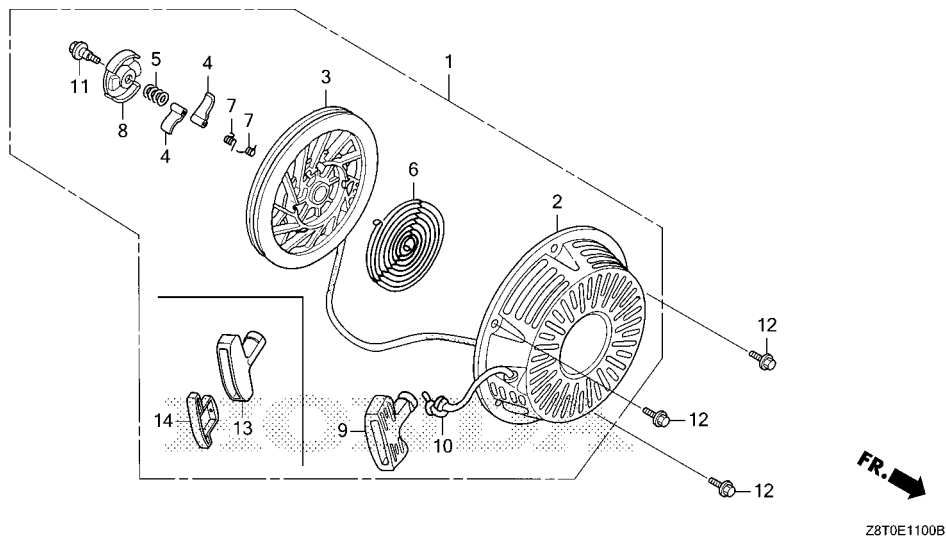

Z8T0E1100B

Ref. No.	Part No.	Description	Reqd. QTY					Serial No.	Parts catalogue code
			GX 340 UT1	GX 340 UT2	GX 340 RT1	GX 340 RT2	GX 340 UT2X		
12	90008-ZE2-003 95701-06010-00	BOLT, FLANGE, 6X10	3	-	3	-	-	EDE2/A, EDN2/A, EDS6/A, EDT6/A, HA2/A, HX26/A, LXQ4/A, PKT2/A, PKX2/A, QA2/A, QAE2/A, QAE6/A, QAH2/A, QAP2/A, QE/A, QHB4/A, QKA4/A, QMT2/A, QNE2/A, QNR2/A, QWC/A, QXB7/A, QXE4/A, QXQ4/A, QXU/A, SE/A, SE1, SE2, SHQ4/A, SME0/A, SXE4/A, SXQ4/A, VWC/A, VWE/A, VWE2/A, VWS1, VWS1/A, VX16/A, VX8/A, VXE2/A, VXE8/A	
	90008-ZE2-003		-	3	-	-	1064458	HA2, HX26, LX2, LXE4, LXQ4, LXU, PKT2, PKX2, QA2, QAE2, QAE6, QAG, QAH2, QAP2, QDW9, QE, QHB4, QHQ4, QKA4, QMT2, QNE2, QNR2, QWC, QXB7, QXB9, QXC9, QXE4, QXE6, QXE8, QXQ4, QXU, SE, SHQ4, SME0, SMX2, SXE4, SXE8, SXQ4, VA2, VX16, VX8, VXB7, VXB9, VXE2, VXE8, VXE9	
	95701-06010-00		-	3	-	-	1064459	HA2, HX26, LX2, LXE4, LXQ4, LXU, PKT2, PKX2, QA2, QAE2, QAE6, QAG, QAH2, QAP2, QDW9, QE, QHB4, QHQ4, QKA4, QMT2, QNE2, QNR2, QWC, QXB7, QXB9, QXC9, QXE4, QXE6, QXE8, QXQ4, QXU, SE, SHQ4, SME0, SMX2, SXE4, SXE8, SXQ4, VA2, VX16, VX8, VXB7, VXB9, VXE2, VXE8, VXE9	
	90008-ZE2-003 95701-06010-00		-	-	-	3	1066644	EDE2, EDN2, EDS6, EDT6, QNB2, VDE2, VWC, VWE, VWE2, VWS	
			-	-	-	3	1066645	EDE2, EDN2, EDS6, EDT6, QNB2, VDE2, VWC, VWE, VWE2, VWS	
13	28461-Z5T-003	GRIP, STARTER	-	1	-	1	-	EDE2, EDE2/A, EDN2, EDN2/A, EDS6, EDS6/A, EDT6, EDT6/A, HA2, HA2/A, HX26, HX26/A, LX2, LXE4, LXQ4, LXQ4/A, LXU, PKT2, PKT2/A, PKX2/A, QA2, QA2/A, QAE2, QAE2/A, QAE6, QAE6/A, QAG, QAH2, QAH2/A, QAP2, QAP2/A, QDW9, QE, QE/A, QHB4, QHB4/A, QHQ4, QKA4, QKA4/A, QMT2/A, QNB2, QNE2, QNE2/A, QNR2, QNR2/A, QWC, QWC/A, QXB7, QXB7/A, QXB9, QXC9, QXE4, QXE4/A, QXE6, QXE8, QXQ4, QXQ4/A, QXU, QXU/A, SE, SE/A, SE1, SE2, SHQ4, SHQ4/A, SME0, SME0/A, SXE4, SXE4/A, SXE8, SXQ4, SXQ4/A, VA2, VDE2, VWC, VWC/A, VWE, VWE/A, VWE2, VWE2/A, VWS, VWS1, VWS1/A, VX16, VX16/A, VX8, VX8/A, VXB7, VXB9, VXE2, VXE2/A, VXE8, VXE8/A, VXE9	

E-11

RECOIL STARTER(1)

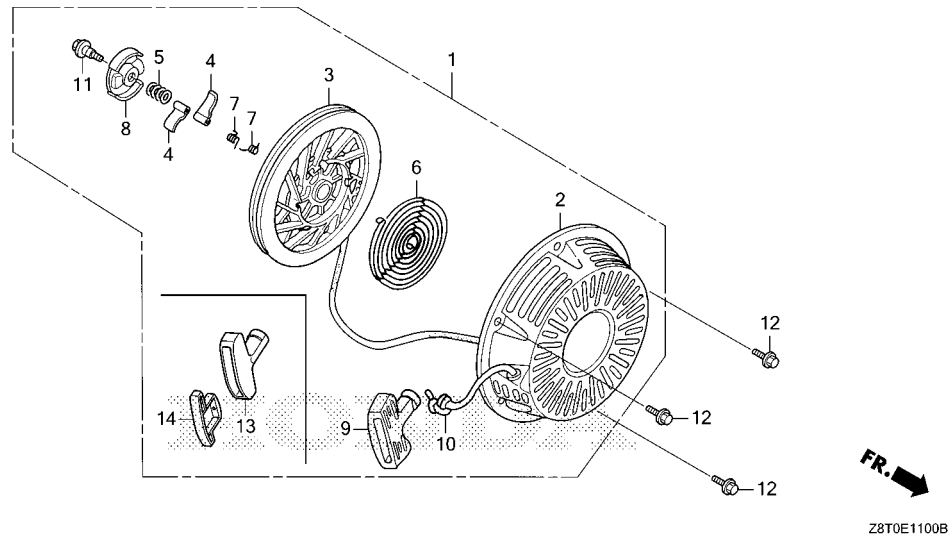

FR. →

Z8T0E1100B

Ref. No.	Part No.	Description	Reqd. QTY					Serial No.	Parts catalogue code
			GX 340 UT1	GX 340 UT2	GX 340 RT1	GX 340 RT2	GX 340 UT2X		
13)	28461-Z5T-305	GRIP, STARTER(COO)(FOR U.S.A.)	-	1	-	1	-	EDE2, EDN2, EDS6, EDT6, HA2, HX26, LX2, LXE4, LXQ4, LXU, PKT2, PKX2, QAE2, QAE6, QAG, QAH2, QAP2, QDW9, QE, QHB4, QHQ4, QKA4, QMT2, QNB2, QNE2, QNR2, QXB7, QXB9, QXC9, QXE4, QXE6, QXE8, QXQ4, QXU, SE, SHQ4, SME0, SMX2, SXE4, SXE8, SXQ4, VA2, VDE2, VWC, VWE, VWE2, VWS, VX16, VX8, VXB7, VXB9, VXE2, VXE8, VXE9	
	28461-Z5T-003	GRIP, STARTER	-	-	-	-	1		
14	28463-Z5T-013	GRIP, REINFORCEMENT	-	1	-	1	-	EDE2, EDE2/A, EDN2, EDN2/A, EDS6, EDS6/A, EDT6, EDT6/A, HA2/A, HX26/A, LXQ4/A, PKT2/A, PKX2, PKX2/A, QA2/A, QAE2/A, QAE6/A, QAH2/A, QAP2/A, QE/A, QHB4/A, QKA4/A, QMT2, QMT2/A, QNE2/A, QNR2/A, QWC, QWC/A, QXB7/A, QXE4/A, QXQ4/A, QXU/A, SE/A, SE1, SE2, SHQ4/A, SME0/A, SMX2, SXE4/A, SXQ4/A, VWC/A, VWE/A, VWE2/A, VWS, VWS1, VWS1/A, VX16/A, VX8/A, VXE2/A, VXE8/A	
	28463-Z5T-003	-	1	-	1	1014917	HA2, HX26, LX2, LXE4, LXQ4, LXU, PKT2, QA2, QAE2, QAE6, QAG, QAH2, QAP2, QDW9, QE, QHB4, QHQ4, QKA4, QNB2, QNE2, QNR2, QXB7, QXB9, QXC9, QXE4, QXE6, QXE8, QXQ4, QXU, SE, SHQ4, SME0, SXE4, SXE8, SXQ4, VA2, VDE2, VWC, VWE, VWE2, VX16, VX8, VXB7, VXB9, VXE2, VXE8, VXE9	
	28463-Z5T-013	-	1	-	1	1014918	HA2, HX26, LX2, LXE4, LXQ4, LXU, PKT2, QA2, QAE2, QAE6, QAG, QAH2, QAP2, QDW9, QE, QHB4, QHQ4, QKA4, QNB2, QNE2, QNR2, QXB7, QXB9, QXC9, QXE4, QXE6, QXE8, QXQ4, QXU, SE, SHQ4, SME0, SXE4, SXE8, SXQ4, VA2, VDE2, VWC, VWE, VWE2, VX16, VX8, VXB7, VXB9, VXE2, VXE8, VXE9	
			-	-	-	-	1		



E-11-1

RECOIL STARTER(2)

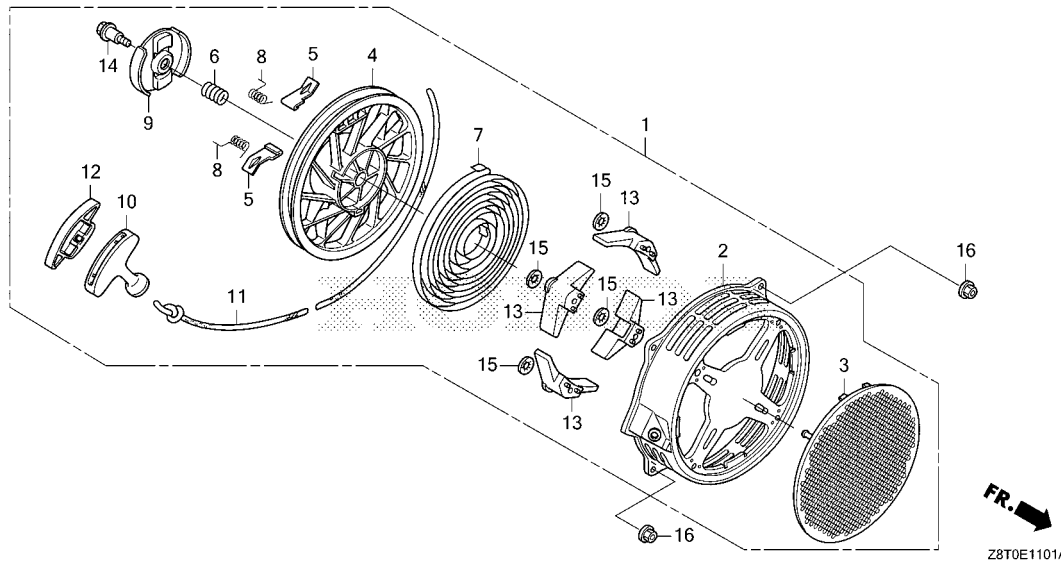

Ref. No. L.O.N. (Relative ref. Number) Description F.R.T.

Ref. No.	Part No.	Description	Reqd. QTY					Serial No.	Parts catalogue code
			GX 340 UT1	GX 340 UT2	GX 340 RT1	GX 340 RT2	GX 340 UT2X		
1	28400-Z5T-W02ZA	STARTER ASSY., RECOIL	-	-	-	-	-		
	NH1BLACK	-	1	-	-	-	1054432 QZA2, QZAV, QZN2, QZX4	
	28400-Z5T-W02ZB	*R280*.....POWER RED	-	1	-	-	-	1054432 QZA2, QZAV, QZN2, QZX4	
	28400-Z5T-W03ZA	*NH1*.....BLACK	-	1	-	-	-	1054433 QZA2, QZAV, QZN2, QZX4	
	28400-Z5T-W03ZB	*R280*.....POWER RED	-	1	-	-	-	1054433 QZA2, QZAV, QZN2, QZX4	
2	28410-Z5T-W02ZA	CASE COMP., RECOIL STARTER	-	-	-	-	-		
	NH1BLACK	-	1	-	-	-	QZA2, QZAV, QZN2, QZX4	
	28410-Z5T-W02ZB	*R280*.....POWER RED	-	1	-	-	-	QZA2, QZAV, QZN2, QZX4	
3	28411-Z5T-W01	COVER, RECOIL STARTER	-	1	-	-	-	QZA2, QZAV, QZN2, QZX4	
4	28421-Z5T-W01	PULLEY, RECOIL STARTER	-	1	-	-	-	QZA2, QZAV, QZN2, QZX4	
5	28422-ZE2-W01	RATCHET, STARTER	-	2	-	-	-	QZA2, QZAV, QZN2, QZX4	
6	28441-ZE2-W01	SPRING, FRICTION	-	1	-	-	-	QZA2, QZAV, QZN2, QZX4	
7	28442-ZE2-W01	SPRING, STARTER RETURN	-	1	-	-	-	QZA2, QZAV, QZN2, QZX4	
8	28443-ZE2-W01	SPRING, RATCHET	-	2	-	-	-	QZA2, QZAV, QZN2, QZX4	
9	28444-ZE2-W01	RETAINER, SPRING	-	1	-	-	-	QZA2, QZAV, QZN2, QZX4	
10	28461-Z5T-003	GRIP, STARTER	-	1	-	-	-	QZA2, QZAV, QZN2, QZX4	
	28461-Z5T-305	GRIP, STARTER(COO)(FOR U.S.A.)	-	1	-	-	-	QZA2, QZAV, QZN2, QZX4	
11	28462-ZE3-W01	ROPE, RECOIL STARTER	-	1	-	-	-	QZA2, QZAV, QZN2, QZX4	
12	28463-Z5T-003	GRIP, REINFORCEMENT	-	1	-	-	-	1054432 QZA2, QZAV, QZN2, QZX4	
	28463-Z5T-013	-	1	-	-	-	1054433 QZA2, QZAV, QZN2, QZX4	
13	28465-Z5T-W01	COVER, ROPE	-	4	-	-	-	QZA2, QZAV, QZN2, QZX4	
14	90004-ZE2-W01	SCREW, CENTER	-	1	-	-	-	QZA2, QZAV, QZN2, QZX4	
15	90201-Z5T-W01	NUT, PUSH	-	4	-	-	-	QZA2, QZAV, QZN2, QZX4	
16	94050-06000	NUT, FLANGE, 6MM	-	4	-	-	-	QZA2, QZAV, QZN2, QZX4	

E-12

FAN COVER(1)

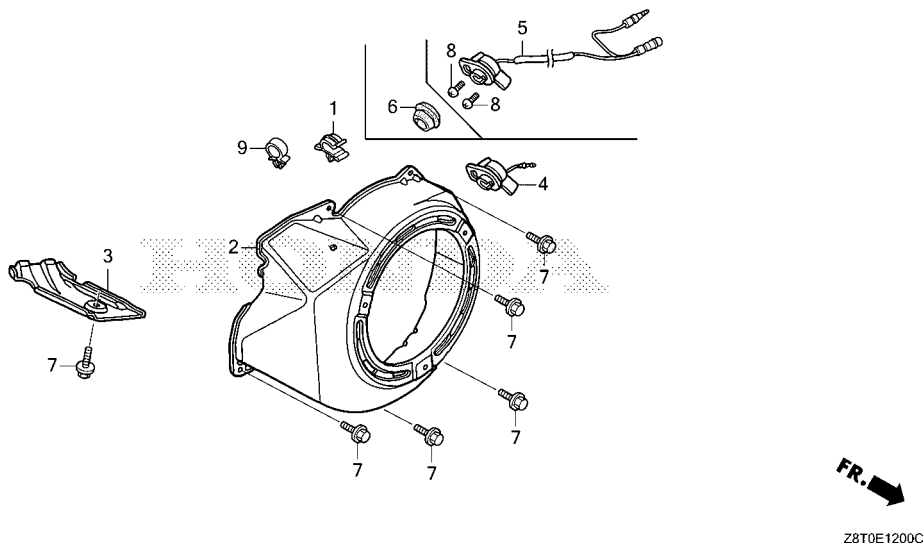

Ref. L.O.N. (Relative ref. Number) F.R.T.
No. Description

Ref. No.	Part No.	Description	Reqd. QTY					Serial No.	Parts catalogue code
			GX 340 UT1	GX 340 UT2	GX 340 RT1	GX 340 RT2	GX 340 UT2X		
1	16731-ZE2-003	CLIP, TUBE.....	1	1	1	1	1	----- HA2, HA2/A, HX26, HX26/A, LX2, LXE4, LXE8, LXQ4, LXQ4/A, LXU, PKT2, PKT2/A, PKX2, PKX2/A, QA2, QA2/A, QA26, QAE2, QAE2/A, QAE6, QAE6/A, QAG, QAH2, QAH2/A, QAP2, QAP2/A, QDW9, QE, QE/A, QHB4, QHB4/A, QHQ4, QKA4, QKA4/A, QMT2, QMT2/A, QNB2, QNE2, QNE2/A, QNR2, QNR2/A, QNR6, QWC, QWC/A, QXB7, QXB7/A, QXB9, QXC4, QXC6, QXC9, QXE4, QXE4/A, QXE6, QXE8, QXQ4, QXQ4/A, QXU, QXU/A, SE, SE/A, SE1, SE2, SHQ4, SHQ4/A, SME0, SME0/A, SMX2, SXE4, SXE4/A, SXE8, SXQ4, SXQ4/A, VA2, VAD2, VC2, VDE2, VW12, VWC, VWC/A, VWE, VWE/A, VWE2, VWE2/A, VWS1, VWS1/A, VX16, VX16/A, VX8, VX8/A, VXB7, VXB9, VXE2, VXE2/A, VXE7, VXE8, VXE8/A, VXE9	
2	19610-ZE3-010ZL	COVER COMP., FAN *R280*.....POWER RED	1	-	1	-	-	----- HA2, HX26, LX2, LXE4, LXE8, LXQ4, LXU, PKT2, QA2, QA26, QAE2, QAE6, QAG, QAH2, QAP2, QE, QHB4, QHQ4, QKA4, QNB2, QNE2, QNR2, QNR6, QXC4, QXC6, QXC9, QXE4, QXE6, QXE8, QXQ4, QXU, SE, SHQ4, SME0, SXE4, SXE8, SXQ4, VA2, VAD2, VC2, VDE2, VW12, VX16, VX8, VXE2, VXE8	
	19610-ZE3-010ZB	*NH1*.....BLACK	1	-	1	-	-	----- PKT2, QA2, QAE2, QAP2, QDW9, QKA4, QNR2, QXC9, QXQ4, QXU, SHQ4, SME0, VC2	
	19610-ZE3-010ZG	*NH105*....MAT BLACK(#15-#20)	1	-	1	-	-	----- VDE2, VW12, VWC, VWE, VWE2, VXE2	
	19610-ZE3-010ZC	*T34*.....SIMPSON BLUE	1	-	-	-	-	----- QA2	
	19610-ZE3-010ZE	*T41*...BARTELL BLUE METALLIC	1	-	-	-	-	----- QA2, QA26	
	19610-ZE3-W02ZF	*R280*.....POWER RED	1	-	-	-	-	----- QXB7, QXB9, VXB7, VXB9, VXE7, VXE9	
	19610-ZE3-W02ZE	*NH105*....MAT BLACK(#15-#20)	1	-	-	-	-	----- VXB7, VXB9, VXE7, VXE9	
	19610-Z5T-000ZA	*R280*.....POWER RED	-	1	-	1	1	----- HA2, HA2/A, HX26, HX26/A, LX2, LXE4, LXQ4, LXQ4/A, LXU, PKT2, PKT2/A, PKX2, PKX2/A, QA2, QA2/A, QAE2, QAE2/A, QAE6, QAE6/A, QAG, QAH2, QAH2/A, QAP2, QAP2/A, QE, QE/A, QHB4, QHB4/A, QHQ4, QKA4, QKA4/A, QMT2, QMT2/A, QNB2, QNE2, QNE2/A, QNR2, QNR2/A, QXC9, QXC9, QXE4/A, QXE6, QXE8, QXQ4, QXQ4/A, QXU, QXU/A, SE, SE/A, SE1, SHQ4, SHQ4/A, SME0, SME0/A, SMX2, SXE4, SXE4/A, SXE8, SXQ4, SXQ4/A, VA2, VDE2, VX16, VX16/A, VX8, VX8/A, VXE2, VXE2/A, VXE8, VXE8/A	



E-12

FAN COVER(1)

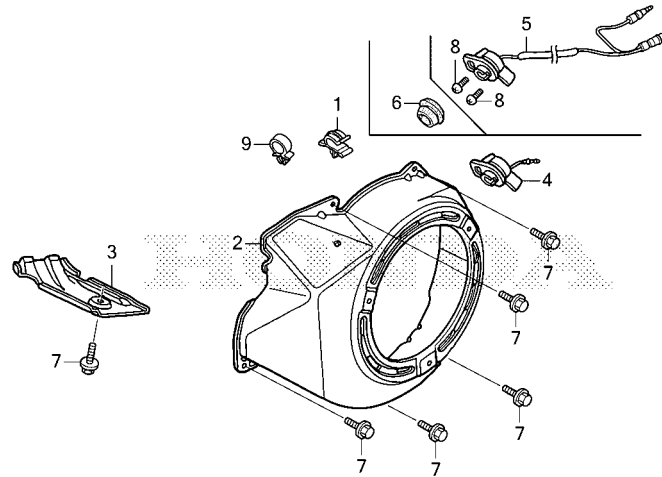

Z8T0E1200C

Ref. No.	Part No.	Description	Reqd. QTY					Serial No.	Parts catalogue code
			GX 340 UT1	GX 340 UT2	GX 340 RT1	GX 340 RT2	GX 340 UT2X		
(2)	19610-Z5T-000ZB	COVER COMP., FAN *NH1*.....BLACK	-	1	-	1	1	-----	PKT2, PKT2/A, PKX2, PKX2/A, QA2, QA2/A, QAE2, QAE2/A, QAP2, QAP2/A, QDW9, QKA4, QKA4/A, QMT2, QMT2/A, QNR2, QNR2/A, QWC, QWC/A, QXC9, QXQ4, QXQ4/A, QXU, QXU/A, SE, SE/A, SE1, SE2, SHQ4, SHQ4/A, SME0, SME0/A, SMX2, VDE2, VWC, VWC/A, VWE, VWE/A, VWE2, VWE2/A, VWS1, VWS1/A, VXE2, VXE2/A
	19610-Z5T-810ZB	*R280*.....POWER RED	-	1	-	-	1	-----	QXB7, QXB7/A, QXB9, VXB7, VXB9, VXE9
	19610-Z5T-810ZA	*NH1*.....BLACK	-	1	-	-	-	-----	VXB7, VXB9, VXE9
	19610-Z5T-800ZA	*R280*.....POWER RED	-	-	-	-	1	-----	EDE2, EDE2/A, EDN2, EDN2/A, EDS6, EDS6/A, EDT6, EDT6/A, VWS
	19610-Z5T-800ZC	*NH1*.....BLACK	-	-	-	-	1	-----	EDE2, EDE2/A, EDN2, EDN2/A, EDS6, EDS6/A, EDT6, EDT6/A, VWS
3	19631-ZE3-W00	SHROUD	1	-	1	-	-	-----	
	19631-Z5T-000		-	1	-	1	1	-----	EDE2, EDE2/A, EDN2, EDN2/A, EDS6, EDS6/A, EDT6, EDT6/A, HA2, HA2/A, HX26, HX26/A, LX2, LXE4, LXQ4, LXQ4/A, LXU, PKT2, PKT2/A, PKX2, PKX2/A, QA2, QA2/A, QAE2, QAE2/A, QAE6, QAE6/A, QAG, QAH2, QAH2/A, QAP2, QAP2/A, QDW9, QE, QE/A, QHB4, QHB4/A, QHQ4, QKA4, QKA4/A, QMT2, QMT2/A, QNB2, QNE2, QNE2/A, QNR2, QNR2/A, QWC, QWC/A, QXB7, QXB7/A, QXB9, QXC9, QXE4, QXE4/A, QXE6, QXE8, QXQ4, QXQ4/A, QXU, QXU/A, SE, SE/A, SE1, SE2, SHQ4, SHQ4/A, SME0, SME0/A, SMX2, SXE4, SXE4/A, SXE8, SXQ4, SXQ4/A, VA2, VDE2, VWC, VWC/A, VWE, VWE/A, VWE2, VWE2/A, VWS, VWS1, VWS1/A, VX16, VX16/A, VX8, VX8/A, VXB7, VXB9, VXE2, VXE2/A, VXE8, VXE8/A, VXE9
4	35120-Z0D-V81	SWITCH ASSY., ENGINE STOP	1	-	-	-	-	-----	QE, QHQ4, SE, SHQ4
5	36100-ZF6-P82	SWITCH ASSY., ENGINE STOP	1	-	1	-	-	-----	HA2, HX26, LX2, LXQ4, LXU, PKT2, QA2, QA26, QAG, QAH2, QAP2, QDW9, QKA4, QXB7, QXB9, QXC4, QXC6, QXC9, QXQ4, QXU, SXQ4, VA2, VAD2, VC2, VDE2, VW12, VX16, VX8, VXB7, VXB9

E-12

FAN COVER(1)

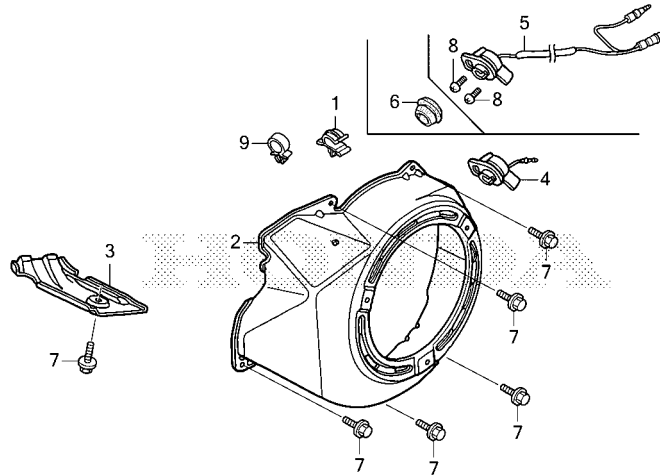

Z8T0E1200C



Ref. No.	Part No.	Description	Reqd. QTY					Serial No.	Parts catalogue code
			GX 340 UT1	GX 340 UT2	GX 340 RT1	GX 340 RT2	GX 340 UT2X		
(5)	35120-Z5T-003	SWITCH ASSY., ENGINE STOP.....	-	1	-	1	1	-----	HA2, HA2/A, HX26, HX26/A, LX2, LXQ4, LXQ4/A, LXU, PKT2, PKT2/A, PKX2, PKX2/A, QA2, QA2/A, QAG, QAH2, QAH2/A, QAP2, QAP2/A, QDW9, QE, QE/A, QHQ4, QKA4, QKA4/A, QMT2, QMT2/A, QWC, QWC/A, QXB7, QXB7/A, QXB9, QXC9, QXQ4, QXQ4/A, QXU, QXU/A, SE, SE/A, SE1, SHQ4, SHQ4/A, SMX2, SXQ4, SXQ4/A, VA2, VDE2, VX16, VX16/A, VX8, VX8/A, VXB7, VXB9
6	81329-567-020	GROMMET, DRAIN HOLE.....	1	1	1	1	1	-----	EDE2, EDE2/A, EDN2, EDN2/A, EDS6, EDS6/A, EDT6, EDT6/A, LXE4, LXE8, QAE2, QAE2/A, QAE6, QAE6/A, QHB4, QHB4/A, QNB2, QNE2, QNE2/A, QNR2, QNR2/A, QNR6, QXE4, QXE4/A, QXE6, QXE8, SE2, SME0, SME0/A, SXE4, SXE4/A, SXE8, VWC, VWC/A, VWE, VWE/A, VWE2, VWE2/A, VWS, VWS1, VXS1/A, VXE2, VXE2/A, VXE7, VXE8, VXE8/A, VXE9
7	90013-883-000	BOLT, FLANGE, 6X12(CT200).....	6	6	6	6	6	-----	EDE2, EDE2/A, EDN2, EDN2/A, EDS6, EDS6/A, EDT6, EDT6/A, HA2, HA2/A, HX26, HX26/A, LX2, LXE4, LXE8, LXQ4, LXQ4/A, LXU, PKT2, PKT2/A, PKX2, PKX2/A, QA2, QA2/A, QA26, QAE2, QAE2/A, QAE6, QAE6/A, QAG, QAH2, QAH2/A, QAP2, QAP2/A, QDW9, QE, QE/A, QHB4, QHB4/A, QHQ4, QKA4, QKA4/A, QMT2, QMT2/A, QNB2, QNE2, QNE2/A, QNR2, QNR2/A, QNR6, QWC, QWC/A, QXB7, QXB7/A, QXB9, QXC4, QXC6, QXC9, QXE4, QXE4/A, QXE6, QXE8, QXQ4, QXQ4/A, QXU, QXU/A, SE, SE/A, SE1, SE2, SHQ4, SHQ4/A, SME0, SME0/A, SMX2, SXE4, SXE4/A, SXE8, SXQ4, SXQ4/A, VA2, VAD2, VC2, VDE2, VW12, VWC, VWC/A, VWE, VWE/A, VWE2, VWE2/A, VWS, VWS1, VWS1/A, VX16, VX16/A, VX8, VX8/A, VXB7, VXB9, VXE2, VXE2/A, VXE7, VXE8, VXE8/A, VXE9
8	90004-Z5T-000	SCREW, TAPPING, 3X6(PO).....	-	2	-	2	2	-----	HA2, HA2/A, HX26, HX26/A, LX2, LXQ4, LXQ4/A, LXU, PKT2, PKT2/A, PKX2, PKX2/A, QA2, QA2/A, QAG, QAH2, QAH2/A, QAP2, QAP2/A, QDW9, QE, QE/A, QHQ4, QKA4, QKA4/A, QMT2, QMT2/A, QWC, QWC/A, QXB7, QXB7/A, QXB9, QXC9, QXQ4, QXQ4/A, QXU, QXU/A, SE, SE/A, SE1, SHQ4, SHQ4/A, SMX2, SXQ4, SXQ4/A, VA2, VDE2, VX16, VX16/A, VX8, VX8/A, VXB7, VXB9
9	90654-SA4-003	CLIP, WIRE HARNESS, 6MM(WHITE)	-	-	-	2	-	-----	EDE2, EDE2/A, EDN2, EDN2/A, EDS6, EDS6/A, EDT6, EDT6/A, VWS

E-12-1

FAN COVER(2)

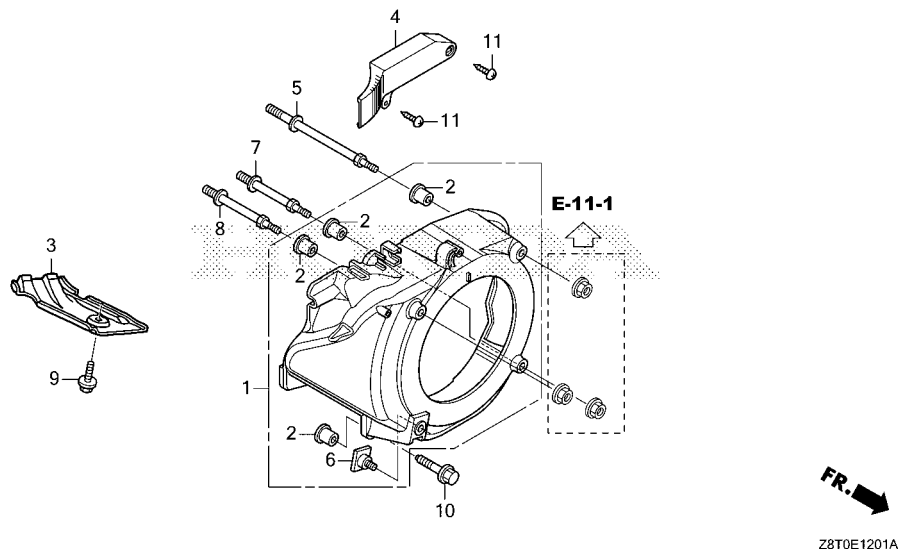

Ref. L.O.N. (Relative ref. Number) F.R.T.
 No. Description

Ref. No.	Part No.	Description	Reqd. QTY					Serial No.	Parts catalogue code
			GX 340 UT1	GX 340 UT2	GX 340 RT1	GX 340 RT2	GX 340 UT2X		
1	19610-Z5T-W00ZA	COVER COMP., FAN	-	-	-	-	-	-	-
		NH1.....BLACK	-	1	-	-	-	-	QZA2, QZAV, QZN2, QZX4
	19610-Z5T-W00ZB	*R280*.....POWER RED	-	1	-	-	-	-	QZA2, QZAV, QZN2, QZX4
2	19619-ZL8-300	COLLAR, FAN COVER.....	-	4	-	-	-	-	QZA2, QZAV, QZN2, QZX4
3	19631-Z5T-000	SHROUD.....	-	1	-	-	-	-	QZA2, QZAV, QZN2, QZX4
4	30421-Z5T-W00	COVER, ELECTRONIC PARTS.....	-	1	-	-	-	-	QZA2, QZAV, QZN2, QZX4
5	90002-Z5T-W00	BOLT, STUD(SEL).....	-	1	-	-	-	-	QZA2, QZAV, QZN2, QZX4
6	90003-Z2E-000	BOLT, SPECIAL, 6MM.....	-	1	-	-	-	-	QZA2, QZAV, QZN2, QZX4
7	90003-Z5T-W00	BOLT, STUD.....	-	1	-	-	-	-	QZA2, QZAV, QZN2, QZX4
8	90007-Z5T-W00	BOLT B, STUD.....	-	1	-	-	-	-	QZA2, QZAV, QZN2, QZX4
9	90013-883-000	BOLT, FLANGE, 6X12(CT200)....	-	1	-	-	-	-	QZA2, QZAV, QZN2, QZX4
10	90121-952-000	BOLT, FLANGE, 6X25(CT200)....	-	1	-	-	-	-	QZA2, QZAV, QZN2, QZX4
11	93913-25580	SCREW, TAPPING, 5X20.....	-	2	-	-	-	-	QZA2, QZAV, QZN2, QZX4

E-14

CARBURETOR(1)

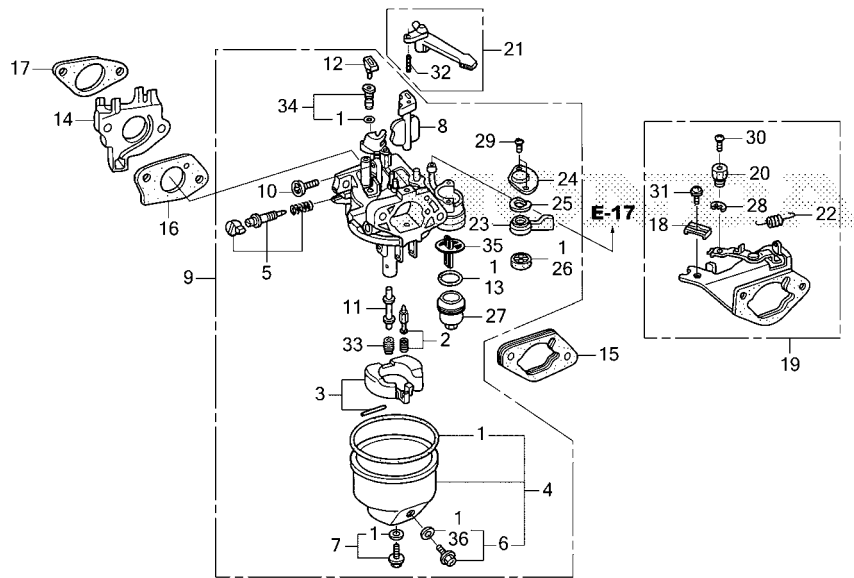

Ref. L.O.N. (Relative ref. Number) F.R.T.
 No. Description

Ref. No.	Part No.	Description	Reqd. QTY					Serial No.	Parts catalogue code
			GX 340 UT1	GX 340 UT2	GX 340 RT1	GX 340 RT2	GX 340 UT2X		
1	16010-ZE2-812	GASKET SET	1	1	1	1	1	-----	HA2, HA2/A, HX26, HX26/A, LX2, LXE4, LXE8, LXQ4, LXQ4/A, LXU, PKT2, PKT2/A, PKX2, PKX2/A, QA2, QA2/A, QA26, QAE2, QAE2/A, QAE6, QAE6/A, QAG, QAH2, QAH2/A, QAP2, QAP2/A, QDW9, QE, QE/A, QHB4, QHB4/A, QHQ4, QKA4, QKA4/A, QMT2, QMT2/A, QNB2, QNE2, QNE2/A, QNR2, QNR2/A, QNR6, QWC, QWC/A, QXB7, QXB7/A, QXB9, QXC4, QXC6, QXC9, QXE4, QXE4/A, QXE6, QXE8, QXQ4, QXQ4/A, QXU, QXU/A, SE, SE/A, SE1, SE2, SHQ4, SHQ4/A, SME0, SME0/A, SMX2, SXE4, SXE4/A, SXE8, SXQ4, SXQ4/A, VA2, VAD2, VDE2, VW12, VWE2, VWE2/A, VX16, VX16/A, VX8, VX8/A, VXB7, VXB9, VXE2, VXE2/A, VXE7, VXE8, VXE8/A, VXE9
2	16011-ZA0-931	VALVE SET, FLOAT	1	1	1	1	1	-----	HA2, HA2/A, HX26, HX26/A, LX2, LXE4, LXE8, LXQ4, LXQ4/A, LXU, PKT2, PKT2/A, PKX2, PKX2/A, QA2, QA2/A, QA26, QAE2, QAE2/A, QAE6, QAE6/A, QAG, QAH2, QAH2/A, QAP2, QAP2/A, QDW9, QE, QE/A, QHB4, QHB4/A, QHQ4, QKA4, QKA4/A, QMT2, QMT2/A, QNB2, QNE2, QNE2/A, QNR2, QNR2/A, QNR6, QWC, QWC/A, QXB7, QXB7/A, QXB9, QXC4, QXC6, QXC9, QXE4, QXE4/A, QXE6, QXE8, QXQ4, QXQ4/A, QXU, QXU/A, SE, SE/A, SE1, SE2, SHQ4, SHQ4/A, SME0, SME0/A, SMX2, SXE4, SXE4/A, SXE8, SXQ4, SXQ4/A, VA2, VAD2, VDE2, VW12, VWE2, VWE2/A, VX16, VX16/A, VX8, VX8/A, VXB7, VXB9, VXE2, VXE2/A, VXE7, VXE8, VXE8/A, VXE9
3	16013-Z1C-003	FLOAT SET	1	-	1	-	-	-----	HA2, HX26, LX2, LXE4, LXE8, LXQ4, LXU, PKT2, QA2, QA26, QAE2, QAE6, QAG, QAH2, QAP2, QDW9, QE, QHB4, QHQ4, QKA4, QNB2, QNE2, QNR2, QNR6, QXB7, QXB9, QXC4, QXC6, QXC9, QXE4, QXE6, QXE8, QXQ4, QXU, SE, SHQ4, SME0, SXE4, SXE8, SXQ4, VA2, VX16, VX8, VXB7, VXB9, VXE2, VXE7, VXE8, VXE9



E-14

CARBURETOR(1)

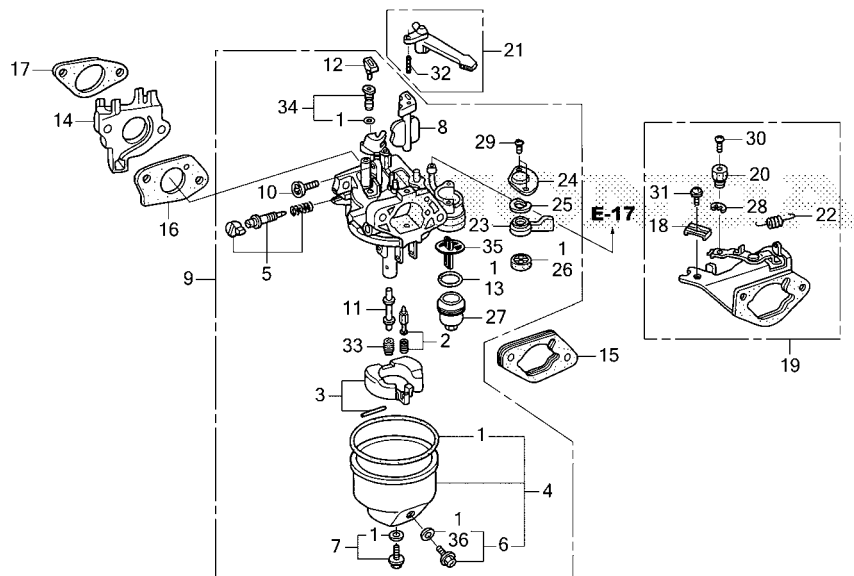

FR. →
Z8T0E1400C

Ref. No.	Part No.	Description	Reqd. QTY					Serial No.	Parts catalogue code
			GX 340 UT1	GX 340 UT2	GX 340 RT1	GX 340 RT2	GX 340 UT2X		
(3)	16013-ZA0-931	FLOAT SET	-	1	1	-	-	HA2, HA2/A, HX26, HX26/A, LX2, LXE4, LXQ4, LXQ4/A, LXU, PKT2, PKT2/A, PKX2, PKX2/A, QA2, QA2/A, QAE2, QAE2/A, QAE6, QAE6/A, QAG, QAH2, QAH2/A, QAP2, QAP2/A, QE, QE/A, QHB4, QHB4/A, QHQ4, QKA4, QKA4/A, QMT2, QMT2/A, QNE2, QNE2/A, QNR2, QNR2/A, QWC, QWC/A, QXB7, QXB7/A, QXB9, QXE4, QXE4/A, QXE6, QXE8, QXQ4, QXQ4/A, QXU, QXU/A, SE, SE/A, SE1, SE2, SHQ4, SHQ4/A, SME0, SME0/A, SMX2, SXE4, SXE4/A, SXE8, SXQ4, SXQ4/A, VA2, VAD2, VDE2, VW12, VWE2, VX16, VX8, VX8/A, VX8/A, VXB7, VXB9, VXE2, VXE2/A, VXE8, VXE8/A, VXE9	
	16013-Z1C-003	-	1	-	-	-	QDW9, QXC9	
	16013-ZA0-931	-	-	-	1	-	QNB2, VDE2, VWE2, VWE2/A	
	16013-Z1C-003	-	-	-	-	1	HA2, HX26, LXQ4, PKT2, PKX2, QAE2, QAE6, QAH2, QAP2, QE, QHB4, QKA4, QMT2, QNR2, QWC, QXB7, QXE4, QXQ4, SE, SE1, SE2, SME0, SXE4, SXQ4, VX8, VXE8	
	16013-ZA0-931	-	-	-	-	1	QA2, QNE2	
4	16015-ZE8-005	CHAMBER SET, FLOAT	1	-	1	-	-	HA2, HX26, LX2, LXE4, LXE8, LXQ4, LXU, PKT2, QA2, QA26, QAE2, QAE6, QAG, QAH2, QAP2, QDW9, QE, QHB4, QHQ4, QKA4, QNB2, QNE2, QNR2, QNR6, QXB7, QXB9, QXC4, QXC6, QXC9, QXE4, QXE6, QXE8, QXQ4, QXU, SE, SHQ4, SME0, SXE4, SXE8, SXQ4, VA2, VAD2, VDE2, VW12, VWE2, VX16, VX8, VXB7, VXB9, VXE2, VXE7, VXE8, VXE9	
	16015-Z5T-901	-	1	-	1	1	HA2, HA2/A, HX26, HX26/A, LX2, LXE4, LXQ4, LXQ4/A, LXU, PKT2, PKT2/A, PKX2, PKX2/A, QA2, QA2/A, QAE2, QAE2/A, QAE6, QAE6/A, QAG, QAH2, QAH2/A, QAP2, QAP2/A, QDW9, QE, QE/A, QHB4, QHB4/A, QHQ4, QKA4, QKA4/A, QMT2, QMT2/A, QNB2, QNE2, QNE2/A, QNR2, QNR2/A, QWC, QWC/A, QXB7, QXB7/A, QXB9, QXC9, QXE4, QXE4/A, QXE6, QXE8, QXQ4, QXQ4/A, QXU, QXU/A, SE, SE/A, SE1, SE2, SHQ4, SHQ4/A, SME0, SME0/A, SMX2, SXE4, SXE4/A, SXE8, SXQ4, SXQ4/A, VA2, VDE2, VWE2, VWE2/A, VX16, VX16/A, VX8, VX8/A, VXB7, VXB9, VXE2, VXE2/A, VXE8, VXE8/A, VXE9	

E-14

CARBURETOR(1)

Ref. No.	Part No.	Description	Reqd. QTY					Serial No.	Parts catalogue code
			GX 340 UT1	GX 340 UT2	GX 340 RT1	GX 340 RT2	GX 340 UT2X		
5	16016-ZH7-W01	SCREW SET, PILOT.....	1	1	1	1	1	-----	HA2, HA2/A, HX26, HX26/A, LX2, LXE4, LXE8, LXQ4, LXQ4/A, LXU, PKT2, PKT2/A, PKX2, PKX2/A, QA2, QA2/A, QA26, QAE2, QAE2/A, QAE6, QAE6/A, QAG, QAH2, QAH2/A, QAP2, QAP2/A, QDW9, QE, QE/A, QHB4, QHB4/A, QHQ4, QKA4, QKA4/A, QMT2, QMT2/A, QNB2, QNE2, QNE2/A, QNR2, QNR2/A, QNR6, QWC, QWC/A, QXB7, QXB7/A, QXB9, QXC4, QXC6, QXC9, QXE4, QXE4/A, QXE6, QXE8, QXQ4, QXQ4/A, QXU, QXU/A, SE, SE/A, SE1, SE2, SHQ4, SHQ4/A, SME0, SME0/A, SMX2, SXE4, SXE4/A, SXE8, SXQ4, SXQ4/A, VA2, VAD2, VDE2, VW12, VWE2, VWE2/A, VX16, VX16/A, VX8, VX8/A, VXB7, VXB9, VXE2, VXE2/A, VXE7, VXE8, VXE8/A, VXE9
6	16024-ZE1-811	SCREW SET, DRAIN.....	1	-	1	-	-	-----	HA2, HX26, LX2, LXE4, LXE8, LXQ4, LXU, PKT2, QA2, QA26, QAE2, QAE6, QAG, QAH2, QAP2, QDW9, QE, QHB4, QHQ4, QKA4, QNB2, QNE2, QNR2, QNR6, QXB7, QXB9, QXC4, QXC6, QXC9, QXE4, QXE6, QXE8, QXQ4, QXU, SE, SHQ4, SME0, SXE4, SXE8, SXQ4, VA2, VAD2, VDE2, VW12, VWE2, VX16, VX8, VXB7, VXB9, VXE2, VXE7, VXE8, VXE9
	16024-Z5T-901	-	1	-	1	1	-----	HA2, HA2/A, HX26, HX26/A, LX2, LXE4, LXQ4, LXQ4/A, LXU, PKT2, PKT2/A, PKX2, PKX2/A, QA2, QA2/A, QAE2, QAE2/A, QAE6, QAE6/A, QAG, QAH2, QAH2/A, QAP2, QAP2/A, QDW9, QE, QE/A, QHB4, QHB4/A, QHQ4, QKA4, QKA4/A, QMT2, QMT2/A, QNB2, QNE2, QNE2/A, QNR2, QNR2/A, QWC, QWC/A, QXB7, QXB7/A, QXB9, QXC9, QXE4, QXE4/A, QXE6, QXE8, QXQ4, QXQ4/A, QXU, QXU/A, SE, SE/A, SE1, SE2, SHQ4, SHQ4/A, SME0, SME0/A, SMX2, SXE4, SXE4/A, SXE8, SXQ4, SXQ4/A, VA2, VDE2, VWE2, VWE2/A, VX16, VX16/A, VX8, VX8/A, VXB7, VXB9, VXE2, VXE2/A, VXE8, VXE8/A, VXE9
7	16028-ZE0-005	SCREW SET.....	1	-	1	-	-	-----	HA2, HX26, LX2, LXE4, LXE8, LXQ4, LXU, PKT2, QA2, QA26, QAE2, QAE6, QAG, QAH2, QAP2, QDW9, QE, QHB4, QHQ4, QKA4, QNB2, QNE2, QNR2, QNR6, QXB7, QXB9, QXC4, QXC6, QXC9, QXE4, QXE6, QXE8, QXQ4, QXU, SE, SHQ4, SME0, SXE4, SXE8, SXQ4, VA2, VAD2, VDE2, VW12, VWE2, VX16, VX8, VXB7, VXB9, VXE2, VXE7, VXE8, VXE9
	16028-Z5T-901	-	1	-	1	1	-----	HA2, HA2/A, HX26, HX26/A, LX2, LXE4, LXQ4, LXQ4/A, LXU, PKT2, PKT2/A, PKX2, PKX2/A, QA2, QA2/A, QAE2, QAE2/A, QAE6, QAE6/A, QAG, QAH2, QAH2/A, QAP2, QAP2/A, QDW9, QE, QE/A, QHB4, QHB4/A, QHQ4, QKA4, QKA4/A, QMT2, QMT2/A, QNB2, QNE2, QNE2/A, QNR2, QNR2/A, QWC, QWC/A, QXB7, QXB7/A, QXB9, QXC9, QXE4, QXE4/A, QXE6, QXE8, QXQ4, QXQ4/A, QXU, QXU/A, SE, SE/A, SE1, SE2, SHQ4, SHQ4/A, SME0, SME0/A, SMX2, SXE4, SXE4/A, SXE8, SXQ4, SXQ4/A, VA2, VDE2, VWE2, VWE2/A, VX16, VX16/A, VX8, VX8/A, VXB7, VXB9, VXE2, VXE2/A, VXE8, VXE8/A, VXE9
	16028-ZE0-005	-	1	-	-	-	-----	QDW9, QXC9
8	16044-ZE3-811	CHOKE SET.....	1	-	1	1	-	-----	HA2, HX26, LX2, LXE4, LXE8, LXQ4, LXU, PKT2, QA2, QA26, QAE2, QAE6, QAG, QAH2, QAP2, QDW9, QE, QHB4, QHQ4, QNB2, QNE2, QNR2, QNR6, QXB7, QXB9, QXC6, QXC9, QXE4, QXE6, QXE8, QXQ4, QXU, SE, SHQ4, SME0, SXE4, SXE8, SXQ4, VA2, VAD2, VDE2, VW12, VWE2, VWE2/A, VX16, VX8, VXB7, VXB9, VXE2, VXE7, VXE8, VXE9
	16044-ZE3-W20	1	-	-	-	-	-----	QKA4, QXC4
	16044-ZE3-811	-	1	-	-	1	-----	HA2, HA2/A, HX26, HX26/A, LX2, LXE4, LXQ4, LXQ4/A, LXU, PKT2, PKT2/A, PKX2, PKX2/A, QA2, QA2/A, QAE2, QAE2/A, QAE6, QAE6/A, QAG, QAH2, QAH2/A, QAP2, QAP2/A, QDW9, QE, QE/A, QHB4, QHB4/A, QHQ4, QKA4, QKA4/A, QMT2, QMT2/A, QNE2, QNE2/A, QNR2, QNR2/A, QWC, QWC/A, QXB7, QXB7/A, QXB9, QXC9, QXE4, QXE4/A, QXE6, QXE8, QXQ4, QXQ4/A, QXU, QXU/A, SE, SE/A, SE1, SE2, SHQ4, SHQ4/A, SME0, SME0/A, SMX2, SXE4, SXE4/A, SXE8, SXQ4, SXQ4/A, VA2, VX16, VX16/A, VX8, VX8/A, VXB7, VXB9, VXE2, VXE2/A, VXE8, VXE8/A, VXE9
9	16100-Z8T-811	CARBURETOR ASSY.(BE80J A)....	1	-	1	-	-	-----	HA2, HX26, LX2, LXE4, LXE8, LXQ4, LXU, PKT2, QA2, QA26, QAE2, QAE6, QAG, QAH2, QAP2, QE, QHB4, QHQ4, QNB2, QNE2, QNR2, QNR6, QXB7, QXB9, QXE4, QXE6, QXE8, QXQ4, QXU, SE, SHQ4, SME0, SXE4, SXE8, SXQ4, VX16, QDW9, QXC6, QXC9, QKA4
	16100-Z8T-821	CARBURETOR ASSY.(BE80L A)....	1	-	-	-	-	-----	
	16100-Z8T-831	CARBURETOR ASSY.(BE94C A)....	1	-	-	-	-	-----	



E-14

CARBURETOR(1)

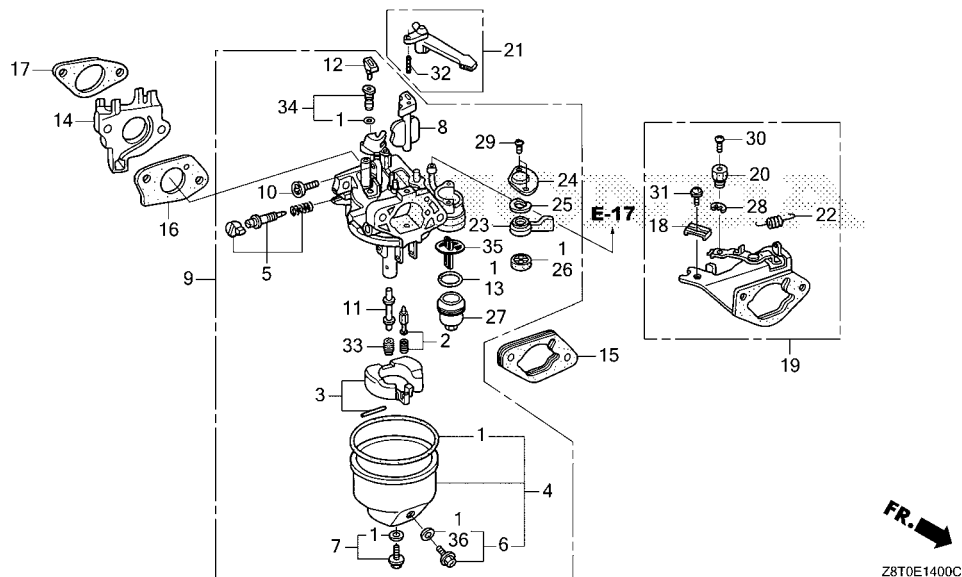

Ref. No.	Part No.	Description	Reqd. QTY					Serial No.	Parts catalogue code
			GX 340 UT1	GX 340 UT2	GX 340 RT1	GX 340 RT2	GX 340 UT2X		
(9)	16100-Z8T-W11	CARBURETOR ASSY.(BE94D A)	1	-	-	-	-	-----	QXC4
	16100-Z8T-801	CARBURETOR ASSY.(BE80K A)	1	-	-	-	-	-----	VA2, VX8, VXB7, VXB9, VXE2, VXE7, VXE8, VXE9
	16100-Z8T-901	CARBURETOR ASSY.(BE80N A)	-	1	-	1	-	1024633	VA2, VDE2, VWE2, VX8, VXB7, VXB9, VXE2, VXE8, VXE9
	16100-Z8T-902	CARBURETOR ASSY.(BE80N B)	-	1	-	1	-	1024634	VA2, VDE2, VWE2, VX8, VXB7, VXB9, VXE2, VXE8, VXE9
	16100-Z8T-911	CARBURETOR ASSY.(BE80M A)	-	1	-	-	-	-----	HA2, HX26, LX2, LXE4, LXQ4, LXU, PKT2, PKX2, QA2, QAE2, QAE6, QAG QAH2, QAP2, QE, QHB4, QHQ4, QMT2, QNE2, QNR2, QWC, QXB7, QXB9, QXE4 QXE6, QXE8, QXQ4, QXU, QXU/A, SE, SHQ4, SME0, SMX2, SXE4, SXE8, SXQ4 VX16
	16100-Z8T-932	CARBURETOR ASSY.(BE80Z A)	-	1	-	-	-	-----	HA2/A, HX26/A, LXQ4/A, PKT2/A, PKX2/A, QA2/A, QAE2/A, QAE6/A QAH2/A, QAP2/A, QE/A, QHB4/A, QKA4/A, QMT2/A, QNE2/A, QNR2/A QWC/A, QXB7/A, QXE4/A, QXQ4/A, SE/A, SE1, SE2, SHQ4/A, SME0/A SXE4/A, SXQ4/A, VX16/A, VX8/A, VXE8/A
	16100-Z8T-922	CARBURETOR ASSY.(BE80Q A)	-	1	-	-	-	-----	QDW9, QXC9
	16100-Z8T-931	CARBURETOR ASSY.(BE80P A)	-	1	-	-	-	-----	QKA4
	16100-Z8T-902	CARBURETOR ASSY.(BE80N B)	-	1	-	-	-	-----	VXE2/A
	16100-ZE3-F31	CARBURETOR ASSY.(BE80D B/C) ..	-	-	1	-	-	-----	VAD2, VDE2, VW12, VWE2
	16100-Z9H-802	CARBURETOR ASSY.(BE80W A/B) ..	-	-	-	1	-	-----	VWE2/A
	16100-Z8T-911	CARBURETOR ASSY.(BE80M A)	-	-	-	1	-	1079912	QNB2
	16100-Z9H-811	CARBURETOR ASSY.(BE80Y A)	-	-	-	1	-	1079913	QNB2
	16100-Z8T-932	CARBURETOR ASSY.(BE80Z A)	-	-	-	-	1	-----	
10	16124-ZE0-005	SCREW, THROTTLE STOP	1	1	1	1	1	-----	HA2, HA2/A, HX26, HX26/A, LX2, LXE4, LXE8, LXQ4, LXQ4/A, LXU, PKT2 PKT2/A, PKX2, PKX2/A, QA2, QA2/A, QA26, QAE2, QAE2/A, QAE6, QAE6/A QAG, QAH2, QAH2/A, QAP2, QAP2/A, QDW9, QE, QE/A, QHB4, QHB4/A, QHQ4 QKA4, QKA4/A, QMT2, QMT2/A, QNB2, QNE2, QNE2/A, QNR2, QNR2/A, QNR6 QWC, QWC/A, QXB7, QXB7/A, QXB9, QXC4, QXC6, QXC9, QXE4, QXE4/A QXE6, QXE8, QXQ4, QXQ4/A, QXU, QXU/A, SE, SE/A, SE1, SE2, SHQ4 SHQ4/A, SME0, SME0/A, SMX2, SXE4, SXE4/A, SXE8, SXQ4, SXQ4/A, VA2 VAD2, VDE2, VW12, VWE2, VWE2/A, VX16, VX16/A, VX8, VX8/A, VXB7 VXB9, VXE2, VXE2/A, VXE7, VXE8, VXE8/A, VXE9

E-14

CARBURETOR(1)

Ref. No.	Part No.	Description	Reqd. QTY					Serial No.	Parts catalogue code
			GX 340 UT1	GX 340 UT2	GX 340 RT1	GX 340 RT2	GX 340 UT2X		
11	16166-ZE3-W50	NOZZLE, MAIN	1	-	1	-	-	HA2, HX26, LX2, LXE4, LXE8, LXQ4, LXU, PKT2, QA2, QA26, QAE2, QAE6 QAG, QAH2, QAP2, QDW9, QE, QHB4, QHQ4, QNB2, QNE2, QNR2, QNR6, QXB7 QXB9, QXC6, QXC9, QXE4, QXE6, QXE8, QXQ4, QXU, SE, SHQ4, SME0, SXE4 SXE8, SXQ4, VX16	
	16166-ZE3-F30	1	-	1	-	-	VA2, VAD2, VDE2, VW12, VWE2, VX8, VXB7, VXB9, VXE2, VXE7, VXE8, VXE9	
	16166-ZE3-W20	1	-	-	-	-	QKA4	
	16166-ZE3-W10	1	-	-	-	-	QXC4	
	16166-Z8T-911	-	1	-	1	-	HA2, HX26, LX2, LXE4, LXQ4, LXU, PKT2, PKX2, QA2, QAE2, QAE6, QAG QAH2, QAP2, QE, QHB4, QHQ4, QKA4, QMT2, QNB2, QNE2, QNR2, QWC, QXB7 QXB9, QXE4, QXE6, QXE8, QXQ4, QXU, QXU/A, SE, SHQ4, SME0, SMX2, SXE4 SXE8, SXQ4, VA2, VDE2, VWE2, VX16, VX8, VXB7, VXB9, VXE2, VXE2/A VXE8, VXE9	
	16166-Z8T-WB1	-	1	-	1	-	HA2/A, HX26/A, LXQ4/A, PKT2/A, PKX2/A, QA2/A, QAE2/A, QAE6/A QAH2/A, QAP2/A, QE/A, QHB4/A, QKA4/A, QMT2/A, QNE2/A, QNR2/A QWC/A, QXB7/A, QXE4/A, QXQ4/A, SE/A, SE1, SE2, SHQ4/A, SME0/A SXE4/A, SXQ4/A, VWE2/A, VX16/A, VX8/A, VXE8/A	
	16166-Z8T-921	-	1	-	-	-	QDW9, QXC9	
	16166-Z8T-WB1	-	-	-	-	1		
12	16172-ZE3-W10	COLLAR, SETTING	1	-	1	1	-	HA2, HX26, LX2, LXE4, LXE8, LXQ4, LXU, PKT2, QA2, QA26, QAE2, QAE6 QAG, QAH2, QAP2, QDW9, QE, QHB4, QHQ4, QNB2, QNE2, QNR2, QNR6, QXB7 QXB9, QXC4, QXC6, QXC9, QXE4, QXE6, QXE8, QXQ4, QXU, SE, SHQ4, SME0 SXE4, SXE8, SXQ4, VA2, VAD2, VDE2, VW12, VWE2, VWE2/A, VX16, VX8 VXB7, VXB9, VXE2, VXE7, VXE8, VXE9	
			-	1	-	-	1	HA2, HA2/A, HX26, HX26/A, LX2, LXE4, LXE8, LXQ4, LXQ4/A, LXU, PKT2 PKT2/A, PKX2, PKX2/A, QA2, QA2/A, QAE2, QAE2/A, QAE6, QAE6/A, QAG QAH2, QAH2/A, QAP2, QAP2/A, QDW9, QE, QE/A, QHB4, QHB4/A, QHQ4 QKA4, QKA4/A, QMT2, QMT2/A, QNE2, QNE2/A, QNR2, QNR2/A, QWC, QWC/A QXB7, QXB7/A, QXB9, QXC9, QXE4, QXE4/A, QXE6, QXE8, QXQ4, QXQ4/A QXU, QXU/A, SE, SE/A, SE1, SE2, SHQ4, SHQ4/A, SME0, SME0/A, SMX2 SXE4, SXE4/A, SXE8, SXQ4, SXQ4/A, VA2, VX16, VX16/A, VX8, VX8/A VXB7, VXB9, VXE2, VXE2/A, VXE8, VXE8/A, VXE9	
13	16173-001-004	O-RING	1	1	1	1	1	HA2, HA2/A, HX26, HX26/A, LX2, LXE4, LXE8, LXQ4, LXQ4/A, LXU, PKT2 PKT2/A, PKX2, PKX2/A, QA2, QA2/A, QA26, QAE2, QAE2/A, QAE6, QAE6/A, QAG QAH2, QAH2/A, QAP2, QAP2/A, QDW9, QE, QE/A, QHB4, QHB4/A, QHQ4 QKA4, QKA4/A, QMT2, QMT2/A, QNB2, QNE2, QNE2/A, QNR2, QNR2/A, QNR6 QWC, QWC/A, QXB7, QXB7/A, QXB9, QXC4, QXC6, QXC9, QXE4, QXE4/A QXE6, QXE8, QXQ4, QXQ4/A, QXU, QXU/A, SE, SE/A, SE1, SE2, SHQ4, SHQ4/A, SME0, SME0/A, SMX2, SXE4, SXE4/A, SXE8, SXQ4, SXQ4/A, VA2 VAD2, VDE2, VW12, VWE2, VWE2/A, VX16, VX16/A, VX8, VX8/A, VXB7 VXB9, VXE2, VXE2/A, VXE7, VXE8, VXE8/A, VXE9	
14	16211-ZE3-000	INSULATOR, CARBURETOR	1	-	1	-	-	HA2, HX26, LX2, LXE4, LXE8, LXQ4, LXU, PKT2, QA2, QA26, QAE2, QAE6 QAG, QAH2, QAP2, QDW9, QE, QHB4, QHQ4, QNB2, QNE2, QNR2, QNR6, QXB7 QXB9, QXC6, QXC9, QXE4, QXE6, QXE8, QXQ4, QXU, SE, SHQ4, SME0, SXE4 SXE8, SXQ4, VA2, VAD2, VDE2, VW12, VWE2, VX16, VX8, VXB7, VXB9, VXE2 VXE7, VXE8, VXE9	
	16211-ZF6-000	1	-	-	-	-	QKA4, QXC4	
	16211-Z8T-000	-	1	-	1	1	HA2, HA2/A, HX26, HX26/A, LX2, LXE4, LXQ4, LXQ4/A, LXU, PKT2 PKT2/A, PKX2, PKX2/A, QA2, QA2/A, QAE2, QAE2/A, QAE6, QAE6/A, QAG QAH2, QAH2/A, QAP2, QAP2/A, QDW9, QE, QE/A, QHB4, QHB4/A, QHQ4 QKA4, QKA4/A, QMT2, QMT2/A, QNB2, QNE2, QNE2/A, QNR2, QNR2/A, QWC QWC/A, QXB7, QXB7/A, QXB9, QXC9, QXE4, QXE4/A, QXE6, QXE8, QXQ4 QXQ4/A, QXU, QXU/A, SE, SE/A, SE1, SE2, SHQ4, SHQ4/A, SME0, SME0/A SMX2, SXE4, SXE4/A, SXE8, SXQ4, SXQ4/A, VA2, VDE2, VWE2, VWE2/A VX16, VX16/A, VX8, VX8/A, VXB7, VXB9, VXE2, VXE2/A, VXE8, VXE8/A VXE9	



E-14

CARBURETOR(1)

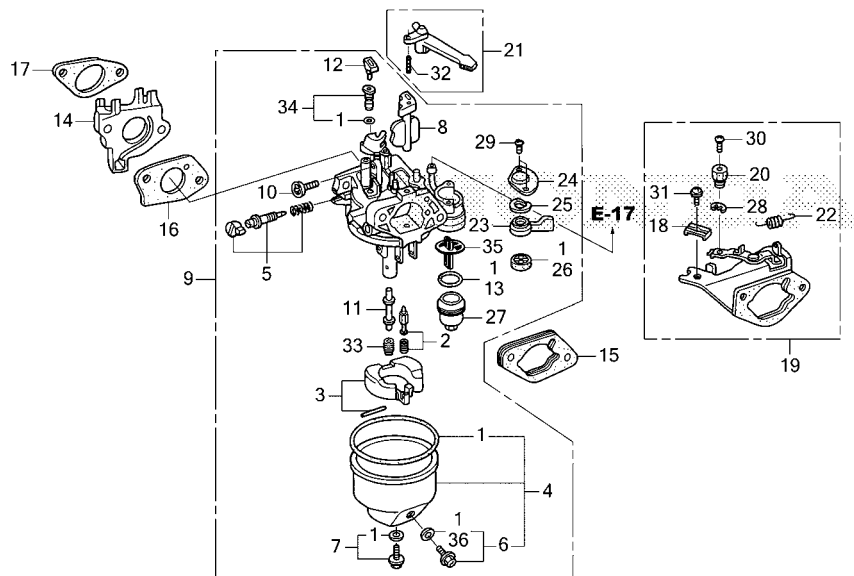

FR. →
Z8T0E1400C

Ref. No.	Part No.	Description	Reqd. QTY					Serial No.	Parts catalogue code
			GX 340 UT1	GX 340 UT2	GX 340 RT1	GX 340 RT2	GX 340 UT2X		
15	16220-ZA0-702	SPACER COMP., CARBURETOR.....	1	1	1	1	1	HA2, HA2/A, HX26, HX26/A, LX2, LXE4, LXE8, LXQ4, LXQ4/A, LXU, PKT2, PKT2/A, PKX2, PKX2/A, QA2, QA2/A, QA26, QAE2, QAE2/A, QAE6, QAE6/A, QAG, QAH2, QAH2/A, QAP2, QAP2/A, QDW9, QE, QE/A, QHB4, QHB4/A, QHQ4, QKA4, QKA4/A, QMT2, QMT2/A, QNE2, QNE2/A, QNR2, QNR2/A, QNR6, QWC, QWC/A, QXB7, QXB7/A, QXB9, QXC4, QXC6, QXC9, QXE4, QXE4/A, QXE6, QXE8, QXQ4, QXQ4/A, QXU, QXU/A, SE, SE/A, SE1, SE2, SHQ4, SHQ4/A, SME0, SME0/A, SMX2, SXE4, SXE4/A, SXE8, SXQ4, SXQ4/A, VA2, VAD2, VDE2, VW12, VWE2, VWE2/A, VX16, VX16/A, VX8, VX8/A, VXB7, VXB9, VXE2, VXE2/A, VXE7, VXE8, VXE8/A, VXE9	
16	16221-ZE3-800	PACKING, CARBURETOR.....	1	-	1	-	-	1019543	HA2, HX26, LX2, LXE4, LXE8, LXQ4, LXU, PKT2, QA2, QA26, QAE2, QAE6, QAG, QAH2, QAP2, QDW9, QE, QHB4, QHQ4, QNB2, QNE2, QNR2, QNR6, QXB7, QXB9, QXC6, QXC9, QXE4, QXE6, QXE8, QXQ4, QXU, SE, SHQ4, SME0, SXE4, SXE8, SXQ4, VA2, VAD2, VDE2, VW12, VWE2, VX16, VX8, VXB7, VXB9, VXE2, VXE7, VXE8, VXE9
	16221-Z8T-000	1	-	1	-	-	1019544	HA2, HX26, LX2, LXE4, LXE8, LXQ4, LXU, PKT2, QA2, QA26, QAE2, QAE6, QAG, QAH2, QAP2, QDW9, QE, QHB4, QHQ4, QNB2, QNE2, QNR2, QNR6, QXB7, QXB9, QXC6, QXC9, QXE4, QXE6, QXE8, QXQ4, QXU, SE, SHQ4, SME0, SXE4, SXE8, SXQ4, VA2, VAD2, VDE2, VW12, VWE2, VX16, VX8, VXB7, VXB9, VXE2, VXE7, VXE8, VXE9
	16221-ZF6-800	1	-	-	-	-	-	QKA4, QXC4
	16221-Z8T-800	-	1	-	1	-	-	HA2/A, HX26/A, LXQ4/A, PKT2/A, PKX2/A, QA2/A, QAE2/A, QAE6/A, QAH2/A, QAP2/A, QE/A, QHB4/A, QKA4/A, QMT2/A, QNE2/A, QNR2/A, QNR6/A, QWC/A, QXB7/A, QXE4/A, QXQ4/A, QXU/A, SE/A, SE1, SE2, SHQ4/A, SME0/A, SXE4/A, SXQ4/A, VWE2/A, VX16/A, VX8/A, VXE2/A, VXE8/A

E-14

CARBURETOR(1)

Ref. No.	Part No.	Description	Reqd. QTY					Serial No.	Parts catalogue code
			GX 340 UT1	GX 340 UT2	GX RT1	GX 340 RT2	GX 340 UT2X		
16)	16221-Z8T-000	PACKING, CARBURETOR.....	-	1	-	1	-	-----	QAG, QNB2, VXE9
			-	1	-	1	-	-----	1145717 HA2, HX26, LX2, LXE4, LXQ4, LXU, PKT2, PKX2, QA2, QAE2, QAE6, QAH2 QAP2, QDW9, QE, QHB4, QHQ4, QKA4, QMT2, QNE2, QNR2, QWC, QXB7, QXB9 QXC9, QXE4, QXE6, QXE8, QXQ4, QXU, SE, SHQ4, SME0, SMX2, SXE4, SXE8 SXQ4, VA2, VDE2, VWE2, VX16, VX8, VXB7, VXB9, VXE2, VXE8
	16221-Z8T-800	-	1	-	1	-	-----	1145718 HA2, HX26, LX2, LXE4, LXQ4, LXU, PKT2, PKX2, QA2, QAE2, QAE6, QAH2 QAP2, QDW9, QE, QHB4, QHQ4, QKA4, QMT2, QNE2, QNR2, QWC, QXB7, QXB9 QXC9, QXE4, QXE6, QXE8, QXQ4, QXU, SE, SHQ4, SME0, SMX2, SXE4, SXE8 SXQ4, VA2, VDE2, VWE2, VX16, VX8, VXB7, VXB9, VXE2, VXE8
17	16223-ZE3-800	PACKING, INSULATOR.....	-	-	-	-	-	-----	1 HA2, HX26, LX2, LXE4, LXE8, LXQ4, LXU, PKT2, QA2, QA26, QAE2, QAE6 QAG, QAH2, QAP2, QDW9, QE, QHB4, QHQ4, QNB2, QNE2, QNR2, QNR6, QXB7 QXB9, QXC6, QXC9, QXE4, QXE6, QXE8, QXQ4, QXU, SE, SHQ4, SME0, SXE4 SXE8, SXQ4, VA2, VAD2, VDE2, VW12, VWE2, VX16, VX8, VXB7, VXB9, VXE2 VXE7, VXE8, VXE9
	16223-ZE3-W00	1	-	-	-	-	-----	QKA4, QXC4
	16212-Z5T-000	PACKING, CARBURETOR INSULATOR	-	1	-	1	1	-----	HA2, HA2/A, HX26, HX26/A, LX2, LXE4, LXQ4, LXQ4/A, LXU, PKT2 PKT2/A, PKX2, PKX2/A, QA2, QA2/A, QAE2, QAE2/A, QAE6, QAE6/A, QAG QAH2, QAH2/A, QAP2, QAP2/A, QDW9, QE, QE/A, QHB4, QHB4/A, QHQ4 QKA4, QKA4/A, QMT2, QMT2/A, QNB2, QNE2, QNE2/A, QNR2, QNR2/A, QWC QWC/A, QXB7, QXB7/A, QXB9, QXC9, QXE4, QXE4/A, QXE6, QXE6, QXQ4 QXQ4/A, QXU, QXU/A, SE, SE/A, SE1, SE2, SHQ4, SHQ4/A, SME0, SME0/A SMX2, SXE4, SXE4/A, SXE8, SXQ4, SXQ4/A, VA2, VDE2, VWE2, VWE2/A VX16, VX16/A, VX8, VX8/A, VXB7, VXB9, VXE2, VXE2/A, VXE8, VXE8/A VXE9
18	16576-891-000	HOLDER, CABLE.....	-	-	1	1	-	-----	QNB2
19	16590-ZE2-812	STAY ASSY., CHOKE CONTROL (REMOTE)	-	-	1	1	-	-----	QNB2
20	16594-883-010	HOLDER, WIRE.....	-	-	1	1	-	-----	QNB2
21	16610-ZE1-000	LEVER COMP., CHOKE(STD.).....	1	1	1	1	1	-----	HA2, HA2/A, HX26, HX26/A, LX2, LXE4, LXE8, LXQ4, LXQ4/A, LXU, PKT2 PKT2/A, PKX2, PKX2/A, QA2, QA2/A, QA26, QAE2, QAE2/A, QAE6, QAE6/A QAG, QAH2, QAH2/A, QAP2, QAP2/A, QDW9, QE, QE/A, QHB4, QHB4/A, QHQ4 QKA4, QKA4/A, QMT2, QMT2/A, QNB2, QNE2, QNE2/A, QNR2, QNR2/A, QNR6, QWC QWC/A, QXB7, QXB7/A, QXB9, QXC4, QXC6, QXC9, QXE4, QXE4/A, QXE6 QXE8, QXQ4, QXQ4/A, QXU, QXU/A, SE, SE/A, SE1, SE2, SHQ4, SHQ4/A SME0, SME0/A, SMX2, SXE4, SXE4/A, SXE8, SXQ4, SXQ4/A, VA2, VAD2 VDE2, VW12, VWE2, VWE2/A, VX16, VX16/A, VX8, VX8/A, VXB7, VXB9 VXE2, VXE2/A, VXE7, VXE8, VXE8/A, VXE9
22	16615-ZE2-810	SPRING, RETURN.....	-	-	1	1	-	-----	QNB2
23	16953-ZE1-812	LEVER, COCK.....	1	1	1	1	1	-----	HA2, HA2/A, HX26, HX26/A, LX2, LXE4, LXE8, LXQ4, LXQ4/A, LXU, PKT2 PKT2/A, PKX2, PKX2/A, QA2, QA2/A, QA26, QAE2, QAE2/A, QAE6, QAE6/A QAG, QAH2, QAH2/A, QAP2, QAP2/A, QDW9, QE, QE/A, QHB4, QHB4/A, QHQ4 QKA4, QKA4/A, QMT2, QMT2/A, QNB2, QNE2, QNE2/A, QNR2, QNR2/A, QNR6 QWC, QWC/A, QXB7, QXB7/A, QXB9, QXC4, QXC6, QXC9, QXE4, QXE4/A QXE6, QXE8, QXQ4, QXQ4/A, QXU, QXU/A, SE, SE/A, SE1, SE2, SHQ4 SHQ4/A, SME0, SME0/A, SMX2, SXE4, SXE4/A, SXE8, SXQ4, SXQ4/A, VA2 VAD2, VDE2, VW12, VWE2, VWE2/A, VX16, VX16/A, VX8, VX8/A, VXB7 VXB9, VXE2, VXE2/A, VXE7, VXE8, VXE8/A, VXE9
24	16954-ZE1-812	PLATE, LEVER SETTING.....	1	1	1	1	1	-----	HA2, HA2/A, HX26, HX26/A, LX2, LXE4, LXE8, LXQ4, LXQ4/A, LXU, PKT2 PKT2/A, PKX2, PKX2/A, QA2, QA2/A, QA26, QAE2, QAE2/A, QAE6, QAE6/A QAG, QAH2, QAH2/A, QAP2, QAP2/A, QDW9, QE, QE/A, QHB4, QHB4/A, QHQ4 QKA4, QKA4/A, QMT2, QMT2/A, QNB2, QNE2, QNE2/A, QNR2, QNR2/A, QNR6 QWC, QWC/A, QXB7, QXB7/A, QXB9, QXC4, QXC6, QXC9, QXE4, QXE4/A QXE6, QXE8, QXQ4, QXQ4/A, QXU, QXU/A, SE, SE/A, SE1, SE2, SHQ4 SHQ4/A, SME0, SME0/A, SMX2, SXE4, SXE4/A, SXE8, SXQ4, SXQ4/A, VA2 VAD2, VDE2, VW12, VWE2, VWE2/A, VX16, VX16/A, VX8, VX8/A, VXB7 VXB9, VXE2, VXE2/A, VXE7, VXE8, VXE8/A, VXE9



E-14

CARBURETOR(1)

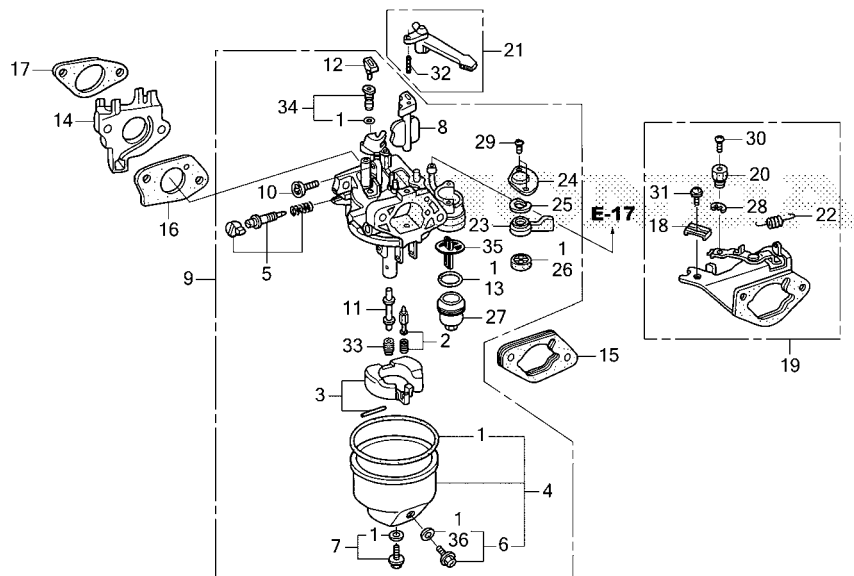

FR. →
Z8T0E1400C

Ref. No.	Part No.	Description	Reqd. QTY					Serial No.	Parts catalogue code
			GX 340 UT1	GX 340 UT2	GX 340 RT1	GX 340 RT2	GX 340 UT2X		
25	16956-ZE1-811	SPRING, COCK LEVER.....	1	1	1	1	1	HA2, HA2/A, HX26, HX26/A, LX2, LXE4, LXE8, LXQ4, LXQ4/A, LXU, PKT2, PKT2/A, PKX2, PKX2/A, QA2, QA2/A, QA26, QAE2, QAE2/A, QAE6, QAE6/A, QAG, QAH2, QAH2/A, QAP2, QAP2/A, QDW9, QE, QE/A, QHB4, QHB4/A, QHQ4, QKA4, QKA4/A, QMT2, QMT2/A, QNB2, QNE2, QNE2/A, QNR2, QNR2/A, QNR6, QWC, QWC/A, QXB7, QXB7/A, QXB9, QXC4, QXC6, QXC9, QXE4, QXE4/A, QXE6, QXE8, QXQ4, QXQ4/A, QXU, QXU/A, SE, SE/A, SE1, SE2, SHQ4, SHQ4/A, SME0, SME0/A, SMX2, SXE4, SXE4/A, SXE8, SXQ4, SXQ4/A, VA2, VAD2, VDE2, VW12, VWE2, VWE2/A, VX16, VX16/A, VX8, VX8/A, VXB7, VXB9, VXE2, VXE2/A, VXE7, VXE8, VXE8/A, VXE9	
26	16957-ZE1-812	PACKING, FUEL COCK.....	1	1	1	1	1	HA2, HA2/A, HX26, HX26/A, LX2, LXE4, LXE8, LXQ4, LXQ4/A, LXU, PKT2, PKT2/A, PKX2, PKX2/A, QA2, QA2/A, QA26, QAE2, QAE2/A, QAE6, QAE6/A, QAG, QAH2, QAH2/A, QAP2, QAP2/A, QDW9, QE, QE/A, QHB4, QHB4/A, QHQ4, QKA4, QKA4/A, QMT2, QMT2/A, QNB2, QNE2, QNE2/A, QNR2, QNR2/A, QNR6, QWC, QWC/A, QXB7, QXB7/A, QXB9, QXC4, QXC6, QXC9, QXE4, QXE4/A, QXE6, QXE8, QXQ4, QXQ4/A, QXU, QXU/A, SE, SE/A, SE1, SE2, SHQ4, SHQ4/A, SME0, SME0/A, SMX2, SXE4, SXE4/A, SXE8, SXQ4, SXQ4/A, VA2, VAD2, VDE2, VW12, VWE2, VWE2/A, VX16, VX16/A, VX8, VX8/A, VXB7, VXB9, VXE2, VXE2/A, VXE7, VXE8, VXE8/A, VXE9	
27	16967-ZE0-811	CUP, FUEL STRAINER.....	1	1	1	1	1	HA2, HA2/A, HX26, HX26/A, LX2, LXE4, LXE8, LXQ4, LXQ4/A, LXU, PKT2, PKT2/A, PKX2, PKX2/A, QA2, QA2/A, QA26, QAE2, QAE2/A, QAE6, QAE6/A, QAG, QAH2, QAH2/A, QAP2, QAP2/A, QDW9, QE, QE/A, QHB4, QHB4/A, QHQ4, QKA4, QKA4/A, QMT2, QMT2/A, QNB2, QNE2, QNE2/A, QNR2, QNR2/A, QNR6, QWC, QWC/A, QXB7, QXB7/A, QXB9, QXC4, QXC6, QXC9, QXE4, QXE4/A, QXE6, QXE8, QXQ4, QXQ4/A, QXU, QXU/A, SE, SE/A, SE1, SE2, SHQ4, SHQ4/A, SME0, SME0/A, SMX2, SXE4, SXE4/A, SXE8, SXQ4, SXQ4/A, VA2, VAD2, VDE2, VW12, VWE2, VWE2/A, VX16, VX16/A, VX8, VX8/A, VXB7, VXB9, VXE2, VXE2/A, VXE7, VXE8, VXE8/A, VXE9	
28	90605-230-000	CIRCLIP, 5MM.....	-	-	1	1	-	QNB2	

E-14

CARBURETOR(1)

Ref. No.	Part No.	Description	Reqd. QTY					Serial No.	Parts catalogue code
			GX 340 UT1	GX 340 UT2	GX 340 RT1	GX 340 RT2	GX 340 UT2X		
29	93500-03006-1H	SCREW, PAN, 3X6	2	2	2	2	2	HA2, HA2/A, HX26, HX26/A, LX2, LXE4, LXE8, LXQ4, LXQ4/A, LXU, PKT2, PKT2/A, PKX2, PKX2/A, QA2, QA2/A, QA26, QAE2, QAE2/A, QAE6, QAE6/A, QAG, QAH2, QAH2/A, QAP2, QAP2/A, QDW9, QE, QE/A, QHB4, QHB4/A, QHQ4, QKA4, QKA4/A, QMT2, QMT2/A, QNB2, QNE2, QNE2/A, QNR2, QNR2/A, QNR6, QWC, QWC/A, QXB7, QXB7/A, QXB9, QXC4, QXC6, QXC9, QXE4, QXE4/A, QXE6, QXE8, QXQ4, QXQ4/A, QXU, QXU/A, SE, SE/A, SE1, SE2, SHQ4, SHQ4/A, SME0, SME0/A, SMX2, SXE4, SXE4/A, SXE8, SXQ4, SXQ4/A, VA2, VAD2, VDE2, VW12, VWE2, VWE2/A, VX16, VX16/A, VX8, VX8/A, VXB7, VXB9, VXE2, VXE2/A, VXE7, VXE8, VXE8/A, VXE9, QNB2	
30	93500-04006-0H	SCREW, PAN, 4X6	-	-	1	1	-	QNB2	
31	93893-05016-00	SCREW-WASHER, 5X16	-	-	1	1	-	QNB2	
32	94305-20122	PIN, SPRING, 2X12	1	1	1	1	1	HA2, HA2/A, HX26, HX26/A, LX2, LXE4, LXE8, LXQ4, LXQ4/A, LXU, PKT2, PKT2/A, PKX2, PKX2/A, QA2, QA2/A, QA26, QAE2, QAE2/A, QAE6, QAE6/A, QAG, QAH2, QAH2/A, QAP2, QAP2/A, QDW9, QE, QE/A, QHB4, QHB4/A, QHQ4, QKA4, QKA4/A, QMT2, QMT2/A, QNE2, QNE2/A, QNR2, QNR2/A, QNR6, QWC, QWC/A, QXB7, QXB7/A, QXB9, QXC4, QXC6, QXC9, QXE4, QXE4/A, QXE6, QXE8, QXQ4, QXQ4/A, QXU, QXU/A, SE, SE/A, SE1, SE2, SHQ4, SHQ4/A, SME0, SME0/A, SMX2, SXE4, SXE4/A, SXE8, SXQ4, SXQ4/A, VA2, VAD2, VDE2, VW12, VWE2, VWE2/A, VX16, VX16/A, VX8, VX8/A, VXB7, VXB9, VXE2, VXE2/A, VXE7, VXE8, VXE8/A, VXE9	
33	99101-ZH8-0900	JET, MAIN, #90	(1)	-	(1)	(1)	-	HA2, HX26, LX2, LXE4, LXE8, LXQ4, LXU, PKT2, QA2, QA26, QAE2, QAE6, QAG, QAH2, QAP2, QE, QHB4, QHQ4, QNB2, QNE2, QNR2, QNR6, QXB7, QXB9, QXE4, QXE6, QXE8, QXQ4, QXU, SE, SHQ4, SME0, SXE4, SXE8, SXQ4, VA2, VAD2, VDE2, VW12, VWE2, VX16, VX8, VXB7, VXB9, VXE2, VXE7, VXE8, VXE9	
	99101-ZH8-0880	JET, MAIN, #88	(1)	-	(1)	-	-	HA2, HX26, LX2, LXE4, LXE8, LXQ4, LXU, PKT2, QA2, QA26, QAE2, QAE6, QAG, QAH2, QAP2, QE, QHB4, QHQ4, QNB2, QNE2, QNR2, QNR6, QXB7, QXB9, QXE4, QXE6, QXE8, QXQ4, QXU, SE, SHQ4, SME0, SXE4, SXE8, SXQ4, VX16	
	99101-ZH8-0920	JET, MAIN, #92	1	-	1	-	-	HA2, HX26, LX2, LXE4, LXE8, LXQ4, LXU, PKT2, QA2, QA26, QAE2, QAE6, QAG, QAH2, QAP2, QE, QHB4, QHQ4, QNB2, QNE2, QNR2, QNR6, QXB7, QXB9, QXE4, QXE6, QXE8, QXQ4, QXU, SE, SHQ4, SME0, SXE4, SXE8, SXQ4, VX16	
			(1)	-	(1)	-	-	QKA4, VA2, VAD2, VDE2, VW12, VWE2, VX8, VXB7, VXB9, VXE2, VXE7, VXE8, VXE9	
	99101-ZH8-0950	JET, MAIN, #95	1	-	1	-	-	VA2, VAD2, VDE2, VW12, VWE2, VX8, VXB7, VXB9, VXE2, VXE7, VXE8, VXE9	
			(1)	-	-	(1)	-	QDW9, QKA4, QNB2, QXC6, QXC9, VDE2, VWE2, VWE2/A	
	99101-ZH8-1000	JET, MAIN, #100	1	-	-	1	-	QDW9, QXC6, QXC9, VWE2/A	
	99101-ZH8-0980	JET, MAIN, #98	1	-	-	1	-	QKA4, QNB2, VDE2, VWE2	
			(1)	-	-	-	-	QDW9, QXC6, QXC9	
	99101-ZH8-1020	JET, MAIN, #102	(1)	-	-	-	-	QXC4	
	99101-ZH8-1050	JET, MAIN, #105	(1)	-	-	-	-	QXC4	
	99101-ZH8-1080	JET, MAIN, #108	1	-	-	-	-	QXC4	
	99101-ZH8-0950	JET, MAIN, #95	-	(1)	-	-	(1)	HA2, HA2/A, HX26, HX26/A, LX2, LXE4, LXQ4, LXQ4/A, LXU, PKT2, PKT2/A, PKX2, PKX2/A, QA2, QA2/A, QAE2, QAE2/A, QAE6, QAE6/A, QAG, QAH2, QAH2/A, QAP2, QAP2/A, QDW9, QE, QE/A, QHB4, QHB4/A, QHQ4, QKA4, QKA4/A, QMT2, QMT2/A, QNE2, QNE2/A, QNR2, QNR2/A, QNR6, QWC, QWC/A, QXB7, QXB7/A, QXB9, QXC9, QXE4, QXE4/A, QXE6, QXE8, QXQ4, QXQ4/A, QXU, QXU/A, SE, SE/A, SE1, SE2, SHQ4, SHQ4/A, SME0, SME0/A, SMX2, SXE4, SXE4/A, SXE8, SXQ4, SXQ4/A, VA2, VX16, VX16/A, VX8, VX8/A, VXB7, VXB9, VXE2, VXE2/A, VXE8, VXE8/A, VXE9	
	99101-ZH8-0900	JET, MAIN, #90	-	(1)	-	-	-	HA2, HX26, LX2, LXE4, LXQ4, LXU, PKT2, PKX2, QA2, QAE2, QAE6, QAG, QAH2, QAP2, QE, QHB4, QHQ4, QKA4, QMT2, QNE2, QNR2, QNR6, QXB7, QXB9, QXE4, QXE6, QXE8, QXQ4, QXU, QXU/A, SE, SHQ4, SME0, SMX2, SXE4, SXE8, SXQ4, VA2, VX16, VX8, VXB7, VXB9, VXE2, VXE2/A, VXE8, VXE9	
	99101-ZH8-0980	JET, MAIN, #98	-	1	-	-	-	HA2, HX26, LX2, LXE4, LXQ4, LXU, PKT2, PKX2, QA2, QAE2, QAE6, QAG, QAH2, QAP2, QE, QHB4, QHQ4, QKA4, QMT2, QNE2, QNR2, QNR6, QXB7, QXB9, QXE4, QXE6, QXE8, QXQ4, QXU, QXU/A, SE, SHQ4, SME0, SMX2, SXE4, SXE8, SXQ4, VA2, VX16, VX8, VXB7, VXB9, VXE2, VXE2/A, VXE8, VXE9	



E-14

CARBURETOR(1)

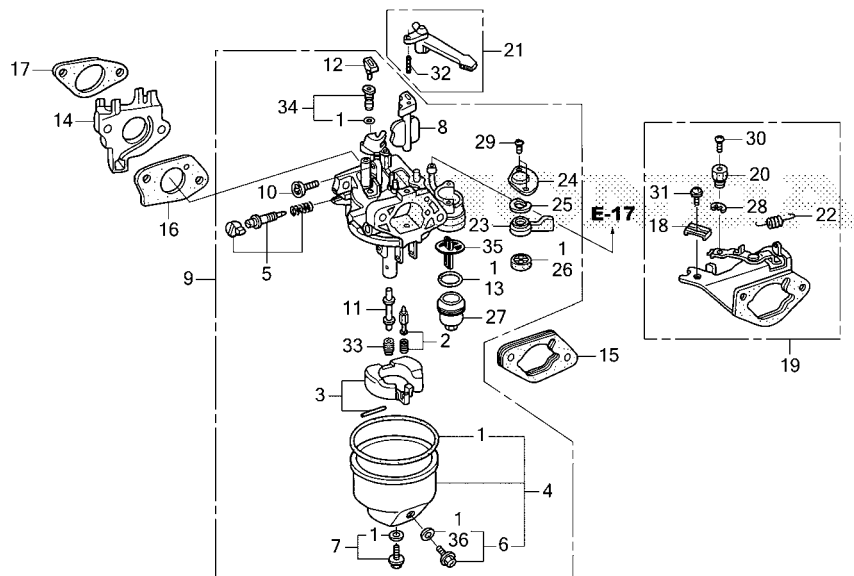

Ref. No.	Part No.	Description	Reqd. QTY					Serial No.	Parts catalogue code
			GX 340 UT1	GX 340 UT2	GX 340 RT1	GX 340 RT2	GX 340 UT2X		
33)	99101-ZH8-0920	JET, MAIN, #92	-	(1)	-	-	-	HA2/A, HX26/A, LXQ4/A, PKT2/A, PKX2/A, QA2/A, QAE2/A, QAE6/A, QAH2/A, QAP2/A, QE/A, QHB4/A, QKA4/A, QMT2/A, QNE2/A, QNR2/A, QWC/A, QXB7/A, QXE4/A, QXQ4/A, SE/A, SE1, SE2, SHQ4/A, SME0/A, SXE4/A, SXQ4/A, VX16/A, VX8/A, VXE8/A	
	99101-ZH8-1000	JET, MAIN, #100	-	1	-	-	-	HA2/A, HX26/A, LXQ4/A, PKT2/A, PKX2/A, QA2/A, QAE2/A, QAE6/A, QAH2/A, QAP2/A, QE/A, QHB4/A, QKA4/A, QMT2/A, QNE2/A, QNR2/A, QWC/A, QXB7/A, QXE4/A, QXQ4/A, SE/A, SE1, SE2, SHQ4/A, SME0/A, SXE4/A, SXQ4/A, VX16/A, VX8/A, VXE8/A	
	99101-ZH8-1020	JET, MAIN, #102	-	(1)	-	-	-	QDW9, QXC9	
	99101-ZH8-0920	JET, MAIN, #92	-	-	-	(1)	-	QDW9, QXC9	
	99101-ZH8-1000	JET, MAIN, #100	-	-	-	(1)	-	VWE2/A	
34	99204-ZE0-0350	JET SET, PILOT, #35	1	-	1	-	-	HA2, HX26, LX2, LXE4, LXE8, LXQ4, LXU, PKT2, QA2, QA26, QAE2, QAE6, QAG, QAH2, QAP2, QDW9, QE, QHB4, QHQ4, QNB2, QNE2, QNR2, QNR6, QXB7, QXB9, QXC6, QXC9, QXE4, QXE6, QXE8, QXQ4, QXU, SE, SHQ4, SME0, SXE4, SXE8, SXQ4, VA2, VAD2, VDE2, VW12, VWE2, VX16, VX8, VXB7, VXB9, VXE2, VXE7, VXE8, VXE9	
	99204-ZE0-0450	JET SET, PILOT, #45	1	-	-	-	-	QKA4	
	99204-ZA0-0400	JET SET, PILOT, #40	1	-	-	-	-	QXC4	
	99204-ZE0-0380	JET SET, PILOT, #38	-	1	-	1	-	HA2, HX26, LX2, LXE4, LXQ4, LXU, PKT2, PKX2, QA2, QAE2, QAE6, QAG, QAH2, QAP2, QE, QHB4, QHQ4, QKA4, QMT2, QNB2, QNE2, QNR2, QWC, QXB7, QXB9, QXE4, QXE6, QXE8, QXQ4, QXU, QXU/A, SE, SHQ4, SME0, SMX2, SXE4, SXE8, SXQ4, VA2, VDE2, VWE2, VX16, VX8, VXB7, VXB9, VXE2, VXE2/A, VXE8, VXE9	
	99204-ZE2-0400	JET SET, PILOT, #40	-	1	-	1	-	HA2/A, HX26/A, LXQ4/A, PKT2/A, PKX2/A, QA2/A, QAE2/A, QAE6/A, QAH2/A, QAP2/A, QE/A, QHB4/A, QKA4/A, QMT2/A, QNE2/A, QNR2/A, QWC/A, QXB7/A, QXE4/A, QXQ4/A, SE/A, SE1, SE2, SHQ4/A, SME0/A, SXE4/A, SXQ4/A, VWE2/A, VX16/A, VX8/A, VXE8/A	



E-14

CARBURETOR(1)

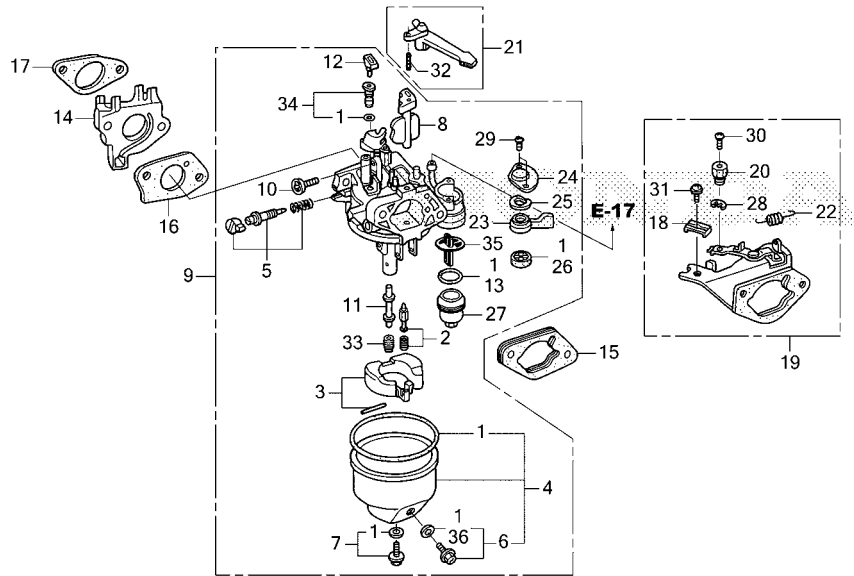

Ref. No.	Part No.	Description	Reqd. QTY					Serial No.	Parts catalogue code
			GX 340 UT1	GX 340 UT2	GX 340 RT1	GX 340 RT2	GX 340 UT2X		
34)	99204-ZE0-0350	JET SET, PILOT, #35	-	1	-	-	-	-----	QDW9,QXC9
	99204-ZE2-0400	JET SET, PILOT, #40	-	-	-	-	1	-----	
35	16959-Z5T-901	FILTER, CUP	-	1	-	1	1	-----	HA2, HA2/A, HX26, HX26/A, LX2, LXE4, LXQ4, LXQ4/A, LXU, PKT2, PKT2/A, PKX2, PKX2/A, QA2, QA2/A, QAE2, QAE2/A, QAE6, QAE6/A, QAG, QAH2, QAH2/A, QAP2, QAP2/A, QDW9, QE, QE/A, QHB4, QHB4/A, QHQ4, QKA4, QKA4/A, QMT2, QMT2/A, QNB2, QNE2, QNE2/A, QNR2, QNR2/A, QWC, QWC/A, QXB7, QXB7/A, QXB9, QXC9, QXE4, QXE4/A, QXE6, QXE8, QXQ4, QXQ4/A, QXU, QXU/A, SE, SE/A, SE1, SE2, SHQ4, SHQ4/A, SME0, SME0/A, SMX2, SXE4, SXE4/A, SXE8, SXQ4, SXQ4/A, VA2, VDE2, VWE2, VWE2/A, VX16, VX16/A, VX8, VX8/A, VXB7, VXB9, VXE2, VXE2/A, VXE8, VXE8/A, VXE9
36	16141-Z0S-003	WASHER, PLAIN(6.2X10.7 DRAIN)	-	1	-	1	1	-----	HA2, HA2/A, HX26, HX26/A, LX2, LXQ4, LXQ4/A, LXU, PKT2, PKT2/A, PKX2, PKX2/A, QA2, QA2/A, QAE2, QAE2/A, QAE6, QAE6/A, QAG, QAH2, QAH2/A, QAP2, QAP2/A, QDW9, QE, QE/A, QHB4, QHB4/A, QHQ4, QKA4, QKA4/A, QMT2, QMT2/A, QNB2, QNE2, QNE2/A, QNR2, QNR2/A, QWC, QWC/A, QXB7, QXB7/A, QXB9, QXC9, QXE4, QXE4/A, QXE6, QXE8, QXQ4, QXQ4/A, QXU, QXU/A, SE, SE/A, SE1, SE2, SHQ4, SHQ4/A, SME0, SME0/A, SMX2, SXE4, SXE4/A, SXE8, SXQ4, SXQ4/A, VA2, VDE2, VWE2, VWE2/A, VX16, VX16/A, VX8, VX8/A, VXB7, VXB9, VXE2, VXE2/A, VXE8, VXE8/A, VXE9



E-14-1

CARBURETOR(2)

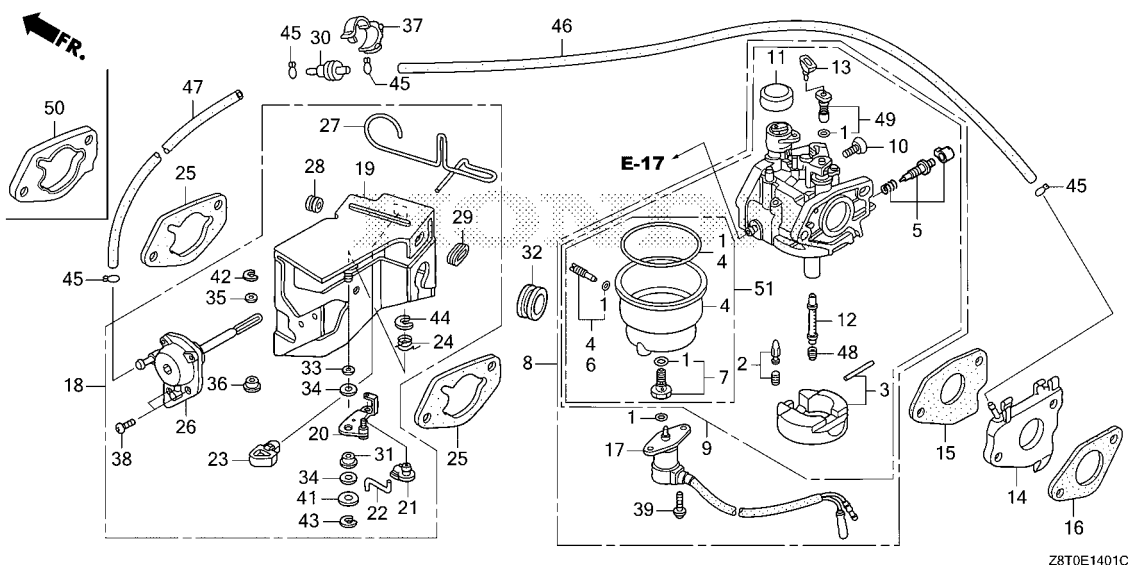

Ref. L.O.N. (Relative ref. Number) F.R.T.
 No. Description

Ref. No.	Part No.	Description	Reqd. QTY					Serial No.	Parts catalogue code
			GX 340 UT1	GX 340 UT2	GX 340 RT1	GX 340 RT2	GX 340 UT2X		
1	16010-ZE3-701	GASKET SET	-	-	1	1	-	EDE2, EDE2/A, EDN2, EDN2/A, EDS6, EDS6/A, EDT6, EDT6/A, VWC, VWC/A, VWE, VWE/A, VWS, VWS1, VWS1/A	
	16010-ZA0-921	-	-	1	-	-	VC2	
2	16011-ZA0-931	VALVE SET, FLOAT	-	-	1	1	-	EDE2, EDE2/A, EDN2, EDN2/A, EDS6, EDS6/A, EDT6, EDT6/A, VC2, VWC, VWC/A, VWE, VWE/A, VWS, VWS1, VWS1/A	
3	16013-Z1C-003	FLOAT SET	-	-	1	-	-	VC2	
	16013-ZA0-931	-	-	1	-	-	VWC, VWE	
	16013-Z1C-003	-	-	-	1	-	EDE2, EDE2/A, EDN2, EDN2/A, EDS6, EDS6/A, EDT6, EDT6/A, VWC, VWC/A, VWE, VWE/A, VWS, VWS1, VWS1/A	
4	16015-ZA0-931	CHAMBER SET, FLOAT	-	-	1	1	-	EDE2, EDE2/A, EDN2, EDN2/A, EDS6, EDS6/A, EDT6, EDT6/A, VWC, VWC/A, VWE, VWE/A, VWS, VWS1, VWS1/A	
5	16016-ZH7-W01	SCREW SET, PILOT	-	-	1	1	-	EDE2, EDN2, EDS6, EDT6, VC2, VWC, VWE, VWS, VWS1	
	16016-Z1E-V21	SCREW SET	-	-	-	1	-	EDE2/A, EDN2/A, EDS6/A, EDT6/A, VWC/A, VWE/A, VWS1/A	
6	16024-124-760	SCREW SET, DRAIN	-	-	1	1	-	EDE2, EDE2/A, EDN2, EDN2/A, EDS6, EDS6/A, EDT6, EDT6/A, VC2, VWC, VWC/A, VWE, VWE/A, VWS, VWS1, VWS1/A	
7	16028-ZA0-931	SCREW SET	-	-	1	1	-	EDE2, EDN2, EDS6, EDT6, VWC, VWE, VWS	
	16028-Z7E-E61	-	-	-	1	-	EDE2/A, EDN2/A, EDS6/A, EDT6/A, VWC/A, VWE/A, VWS1, VWS1/A	
8	16100-Z5L-F12	CARBURETOR ASSY. (BE82M B)	-	-	1	-	-	VWC, VWE	
	16100-Z9H-702	CARBURETOR ASSY. (BE82V A)	-	-	-	1	-	EDE2, EDN2, EDS6, EDT6, VWC, VWE, VWS	
	16100-Z9H-WA1	CARBURETOR ASSY. (BEA5C B)	-	-	-	1	-	EDE2/A, EDN2/A, EDS6/A, EDT6/A, VWC/A, VWE/A, VWS1/A	
	16100-Z9H-822	CARBURETOR ASSY. (BEA5B B)	-	-	-	1	-	VWS1	
	16100-Z9H-S61	CARBURETOR ASSY. (BE82T A)	-	-	1	-	-	VC2	
10	16124-ZE0-005	SCREW, THROTTLE STOP	-	-	1	1	-	EDE2, EDE2/A, EDN2, EDN2/A, EDS6, EDS6/A, EDT6, EDT6/A, VC2, VWC, VWC/A, VWE, VWE/A, VWS, VWS1, VWS1/A	
11	16148-141-881	CAP, CHOKE DUST	-	-	1	1	-	EDE2, EDE2/A, EDN2, EDN2/A, EDS6, EDS6/A, EDT6, EDT6/A, VC2, VWC, VWC/A, VWE, VWE/A, VWS, VWS1, VWS1/A	
12	16166-ZE3-F10	NOZZLE, MAIN	-	-	1	1	-	EDE2, EDN2, EDS6, EDT6, VC2, VWC, VWE, VWS, VWS1	

E-14-1

CARBURETOR(2)

Ref. No.	Part No.	Description	Reqd. QTY					Serial No.	Parts catalogue code
			GX 340 UT1	GX 340 UT2	GX 340 RT1	GX 340 RT2	GX 340 UT2X		
12)	16166-Z9H-WA1	NOZZLE, MAIN	-	-	-	1	-	EDE2/A, EDN2/A, EDS6/A, EDT6/A, VWC/A, VWE/A, VWS1/A	
13	16172-ZE3-W10	COLLAR, SETTING	-	-	1	1	-	EDE2, EDE2/A, EDN2, EDN2/A, EDS6, EDS6/A, EDT6, EDT6/A, VC2, VWC VWC/A, VWE, VWE/A, VWS, VWS1, VWS1/A	
14	16211-ZE3-700	INSULATOR, CARBURETOR	-	-	1	-	-	VC2, VWC, VWE	
	16211-Z9H-700		-	-	-	1	-	EDE2, EDE2/A, EDN2, EDN2/A, EDS6, EDS6/A, EDT6, EDT6/A, VWC, VWC/A VWE, VWE/A, VWS, VWS1, VWS1/A	
15	16221-ZE3-800	PACKING, CARBURETOR	-	-	1	-	1019543	VC2, VWC, VWE	
	16221-Z8T-000		-	-	1	-	1019544	VC2, VWC, VWE	
	16221-Z8T-800		-	-	-	1	-	EDE2/A, EDN2/A, EDS6/A, EDT6/A, VWC/A, VWE/A, VWS1, VWS1/A	
	16221-Z8T-000		-	-	-	1	1145717	EDE2, EDN2, EDS6, EDT6, VWC, VWE, VWS	
	16221-Z8T-800		-	-	-	1	1145718	EDE2, EDN2, EDS6, EDT6, VWC, VWE, VWS	
16	16223-ZE3-800	PACKING, INSULATOR	-	-	1	-	-	VC2, VWC, VWE	
	16212-Z5T-000	PACKING, CARBURETOR INSULATOR	-	-	-	1	-	EDE2, EDE2/A, EDN2, EDN2/A, EDS6, EDS6/A, EDT6, EDT6/A, VWC, VWC/A VWE, VWE/A, VWS, VWS1, VWS1/A	
17	16230-ZE3-702	VALVE ASSY., SOLENOID	-	-	1	1	-	EDE2, EDE2/A, EDN2, EDN2/A, EDS6, EDS6/A, EDT6, EDT6/A, VWC, VWC/A VWE, VWE/A, VWS, VWS1, VWS1/A	
18	16260-ZE3-D22	STAY ASSY., MANUAL CHOKE	-	-	1	1	-	EDE2, EDE2/A, EDN2, EDN2/A, EDS6, EDS6/A, EDT6, EDT6/A, VWC, VWC/A VWE, VWE/A, VWS, VWS1, VWS1/A	
	16260-ZE2-723		-	-	1	-	-	VC2	
19	16261-ZE2-702	STAY COMP., SOLENOID	-	-	1	1	-	EDE2, EDE2/A, EDN2, EDN2/A, EDS6, EDS6/A, EDT6, EDT6/A, VC2, VWC VWC/A, VWE, VWE/A, VWS, VWS1, VWS1/A	
20	16262-ZE2-711	LEVER, CHOKE	-	-	1	1	-	EDE2, EDE2/A, EDN2, EDN2/A, EDS6, EDS6/A, EDT6, EDT6/A, VC2, VWC VWC/A, VWE, VWE/A, VWS, VWS1, VWS1/A	
21	16263-ZA0-000	JOINT, ROD	-	-	1	1	-	EDE2, EDE2/A, EDN2, EDN2/A, EDS6, EDS6/A, EDT6, EDT6/A, VC2, VWC VWC/A, VWE, VWE/A, VWS, VWS1, VWS1/A	
22	16264-ZE2-701	ROD, CHOKE	-	-	1	1	-	EDE2, EDE2/A, EDN2, EDN2/A, EDS6, EDS6/A, EDT6, EDT6/A, VC2, VWC VWC/A, VWE, VWE/A, VWS, VWS1, VWS1/A	
23	16265-ZE2-721	STOPPER, CHOKE ROD	-	-	1	1	-	EDE2, EDE2/A, EDN2, EDN2/A, EDS6, EDS6/A, EDT6, EDT6/A, VC2, VWC VWC/A, VWE, VWE/A, VWS, VWS1, VWS1/A	
24	16268-ZE2-721	SPRING, MANUAL CHOKE	-	-	1	1	-	EDE2, EDE2/A, EDN2, EDN2/A, EDS6, EDS6/A, EDT6, EDT6/A, VC2, VWC VWC/A, VWE, VWE/A, VWS, VWS1, VWS1/A	
25	16269-ZA0-800	PACKING, AIR CLEANER	-	-	2	-	-	VC2, VWC, VWE	
	17228-Z5T-000		-	-	-	1	-	EDE2, EDE2/A, EDN2, EDN2/A, EDS6, EDS6/A, EDT6, EDT6/A, VWC/A VWE/A, VWS, VWS1, VWS1/A	
	16269-ZA0-800		-	-	-	1	1004411	VWC, VWE	
	17228-Z5T-000		-	-	-	1	1004412	VWC, VWE	
26	16400-ZE2-704	DIAPHRAGM ASSY.	-	-	1	1	-	EDE2, EDE2/A, EDN2, EDN2/A, EDS6, EDS6/A, EDT6, EDT6/A, VC2, VWC VWC/A, VWE, VWE/A, VWS, VWS1, VWS1/A	
27	16611-ZE3-D21	ROD, CHOKE CONTROL	-	-	1	1	-	EDE2, EDE2/A, EDN2, EDN2/A, EDS6, EDS6/A, EDT6, EDT6/A, VWC, VWC/A VWE, VWE/A, VWS, VWS1, VWS1/A	
	16611-ZE2-711		-	-	1	-	-	VC2	
28	16613-893-000	GROMMET, CHOKE ROD	-	-	1	1	-	EDE2, EDE2/A, EDN2, EDN2/A, EDS6, EDS6/A, EDT6, EDT6/A, VC2, VWC VWC/A, VWE, VWE/A, VWS, VWS1, VWS1/A	
29	16615-893-000	GUIDE, CHOKE ROD	-	-	1	1	-	EDE2, EDE2/A, EDN2, EDN2/A, EDS6, EDS6/A, EDT6, EDT6/A, VC2, VWC VWC/A, VWE, VWE/A, VWS, VWS1, VWS1/A	
30	36135-ZF6-D41	VALVE, DASHPOT CHECK	-	-	1	1	-	EDE2, EDE2/A, EDN2, EDN2/A, EDS6, EDS6/A, EDT6, EDT6/A, VC2, VWC VWC/A, VWE, VWE/A, VWS, VWS1, VWS1/A	
31	53149-964-003	BUSH, ARM PIVOT	-	-	1	1	-	EDE2, EDE2/A, EDN2, EDN2/A, EDS6, EDS6/A, EDT6, EDT6/A, VC2, VWC VWC/A, VWE, VWE/A, VWS, VWS1, VWS1/A	
32	88911-MJ3-000	GROMMET, FENDER	-	-	1	1	-	EDE2, EDE2/A, EDN2, EDN2/A, EDS6, EDS6/A, EDT6, EDT6/A, VC2, VWC VWC/A, VWE, VWE/A, VWS, VWS1, VWS1/A	
33	90431-ZE2-700	WASHER, CHOKE LEVER	-	-	1	1	-	EDE2, EDE2/A, EDN2, EDN2/A, EDS6, EDS6/A, EDT6, EDT6/A, VC2, VWC VWC/A, VWE, VWE/A, VWS, VWS1, VWS1/A	

E-14-1

CARBURETOR(2)

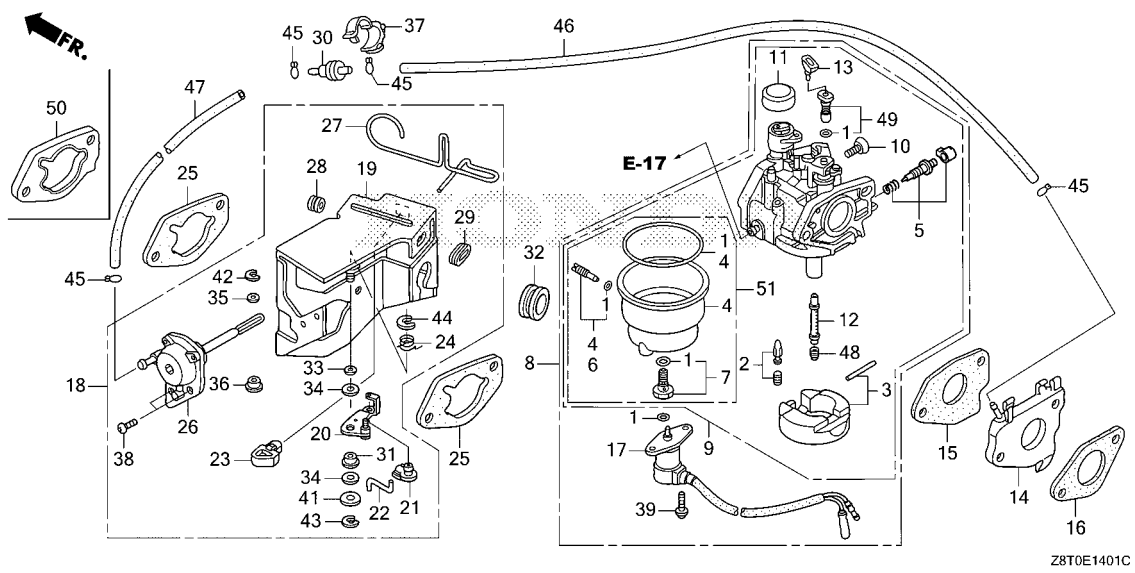

Z8T0E1401C

Ref. No.	Part No.	Description	Reqd. QTY					Serial No.	Parts catalogue code
			GX 340 UT1	GX 340 UT2	GX 340 RT1	GX 340 RT2	GX 340 UT2X		
34	90432-ZE2-700	SEAL, CHOKE LEVER	-	-	2	2	-	EDE2, EDE2/A, EDN2, EDN2/A, EDS6, EDS6/A, EDT6, EDT6/A, VC2, VWC VWC/A, VWE, VWE/A, VWS, VWS1, VWS1/A	
35	90433-ZE2-700	WASHER, THRUST, 2.7X8	-	-	1	1	-	EDE2, EDE2/A, EDN2, EDN2/A, EDS6, EDS6/A, EDT6, EDT6/A, VC2, VWC VWC/A, VWE, VWE/A, VWS, VWS1, VWS1/A	
36	90434-ZE2-700	COLLAR, LEVER	-	-	1	1	-	EDE2, EDE2/A, EDN2, EDN2/A, EDS6, EDS6/A, EDT6, EDT6/A, VC2, VWC VWC/A, VWE, VWE/A, VWS, VWS1, VWS1/A	
37	90650-SD9-003	CLIP, WIRE HARNESS	-	-	1	1	-	EDE2, EDE2/A, EDN2, EDN2/A, EDS6, EDS6/A, EDT6, EDT6/A, VC2, VWC VWC/A, VWE, VWE/A, VWS, VWS1, VWS1/A	
38	93500-05012-0A	SCREW, PAN, 5X12	-	-	2	2	-	EDE2, EDE2/A, EDN2, EDN2/A, EDS6, EDS6/A, EDT6, EDT6/A, VC2, VWC VWC/A, VWE, VWE/A, VWS, VWS1, VWS1/A	
39	93892-05012-18	SCREW-WASHER, 5X12	-	-	2	2	-	EDE2, EDE2/A, EDN2, EDN2/A, EDS6, EDS6/A, EDT6, EDT6/A, VWC, VWC/A VWE, VWE/A, VWS, VWS1, VWS1/A	
41	94103-05000	WASHER, PLAIN, 5MM	-	-	1	1	-	EDE2, EDE2/A, EDN2, EDN2/A, EDS6, EDS6/A, EDT6, EDT6/A, VC2, VWC VWC/A, VWE, VWE/A, VWS, VWS1, VWS1/A	
42	94540-02010	E-RING, 2MM	-	-	1	1	-	EDE2, EDE2/A, EDN2, EDN2/A, EDS6, EDS6/A, EDT6, EDT6/A, VC2, VWC VWC/A, VWE, VWE/A, VWS, VWS1, VWS1/A	
43	94540-04010	E-RING, 4MM	-	-	1	1	-	EDE2, EDE2/A, EDN2, EDN2/A, EDS6, EDS6/A, EDT6, EDT6/A, VC2, VWC VWC/A, VWE, VWE/A, VWS, VWS1, VWS1/A	
44	94540-07010	E-RING, 7MM	-	-	1	1	-	EDE2, EDE2/A, EDN2, EDN2/A, EDS6, EDS6/A, EDT6, EDT6/A, VC2, VWC VWC/A, VWE, VWE/A, VWS, VWS1, VWS1/A	
45	95002-02070	CLIP, TUBE(B7)	-	-	4	4	-	EDE2, EDE2/A, EDN2, EDN2/A, EDS6, EDS6/A, EDT6, EDT6/A, VC2, VWC VWC/A, VWE, VWE/A, VWS, VWS1, VWS1/A	
46	95005-35075-10	TUBE, 3.5X75(95005-35001-10M)	-	-	1	1	-	EDE2, EDE2/A, EDN2, EDN2/A, EDS6, EDS6/A, EDT6, EDT6/A, VC2, VWC VWC/A, VWE, VWE/A, VWS, VWS1, VWS1/A	
47	95005-35130-10	TUBE, 3.5X130(95005-35001-10M)	-	-	1	1	-	EDE2, EDE2/A, EDN2, EDN2/A, EDS6, EDS6/A, EDT6, EDT6/A, VC2, VWC VWC/A, VWE, VWE/A, VWS, VWS1, VWS1/A	

E-14-1

CARBURETOR(2)

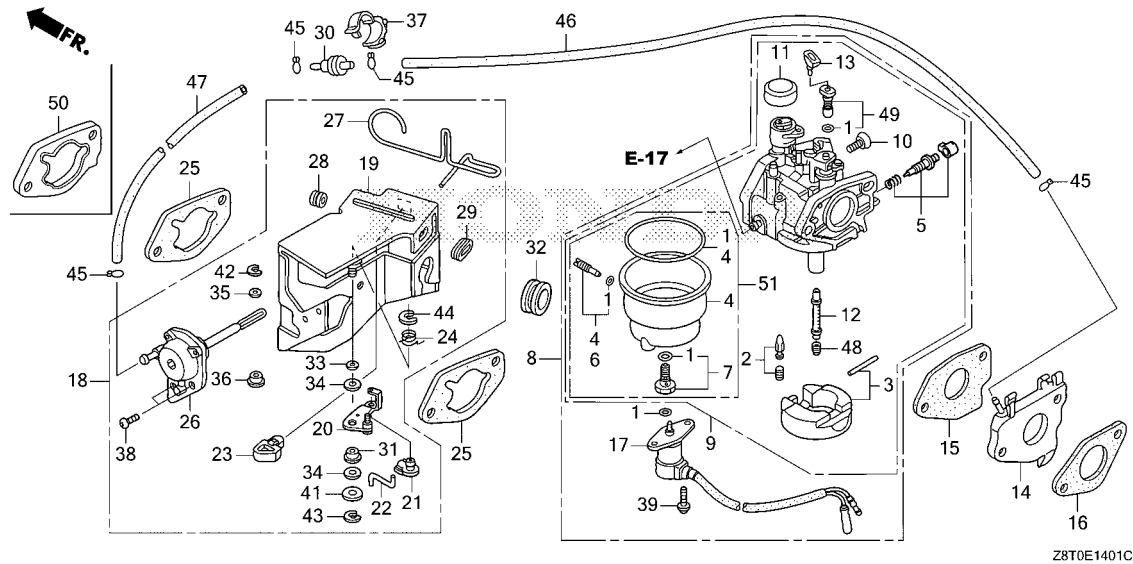

Ref. No.	Part No.	Description	Reqd. QTY					Serial No.	Parts catalogue code
			GX 340 UT1	GX 340 UT2	GX 340 RT1	GX 340 RT2	GX 340 UT2X		
48	99101-ZH8-0950	JET, MAIN, #95	-	-	(1)	(1)	-	EDE2, EDE2/A, EDN2, EDN2/A, EDS6, EDS6/A, EDT6, EDT6/A, VC2, VWC/VWC/A, VWE, VWE/A, VWS, VWS1, VWS1/A	
	99101-ZH8-0980	JET, MAIN, #98	-	-	(1)	(1)	-	EDE2, EDE2/A, EDN2, EDN2/A, EDS6, EDS6/A, EDT6, EDT6/A, VC2, VWC/VWC/A, VWE, VWE/A, VWS, VWS1, VWS1/A	
	99101-ZH8-1000	JET, MAIN, #100	-	-	1	1	-	EDE2, EDN2, EDS6, EDT6, VC2, VWC, VWE, VWS, VWS1	
	99101-ZH8-1020	JET, MAIN, #102	-	-	-	1	-	EDE2/A, EDN2/A, EDS6/A, EDT6/A, VWC/A, VWE/A, VWS1/A	
49	99204-ZE0-0350	JET SET, PILOT, #35	-	-	1	-	-	VC2, VWC, VWE	
	99204-ZE0-0380	JET SET, PILOT, #38	-	-	-	1	-	EDE2, EDE2/A, EDN2, EDN2/A, EDS6, EDS6/A, EDT6, EDT6/A, VWC, VWC/A, VWE, VWE/A, VWS, VWS1, VWS1/A	
50	16220-ZA0-702	SPACER COMP., CARBURETOR	-	-	-	1	-	EDE2, EDE2/A, EDN2, EDN2/A, EDS6, EDS6/A, EDT6, EDT6/A, VWC, VWC/A, VWE, VWE/A, VWS, VWS1, VWS1/A	
51	06160-Z1C-305	BOLT KIT, FUEL CHAMBER	-	-	1	-	-	VC2	



E-14-2

CARBURETOR(3)

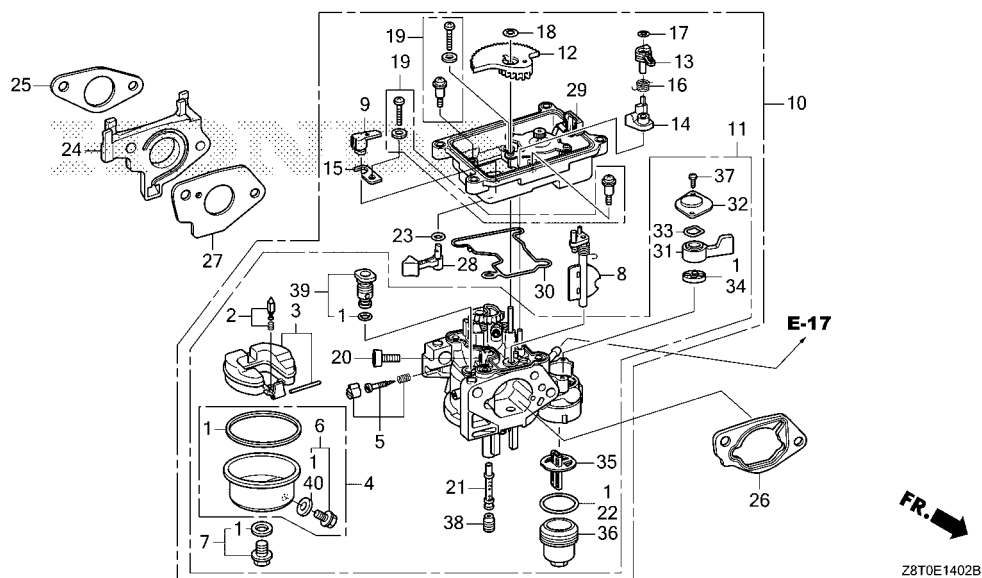

Ref. L.O.N. (Relative ref. Number) F.R.T.
 No. Description

Ref. No.	Part No.	Description	Reqd. QTY					Serial No.	Parts catalogue code
			GX 340 UT1	GX 340 UT2	GX 340 RT1	GX 340 RT2	GX 340 UT2X		
1	16010-ZE2-812	GASKET SET	-	1	-	-	-	-----	QZA2, QZAV, QZN2, QZX4
2	16011-ZA0-931	VALVE SET, FLOAT	-	1	-	-	-	-----	QZA2, QZAV, QZN2, QZX4
3	16013-Z1C-003	FLOAT SET	-	1	-	-	-	-----	QZA2, QZAV, QZN2, QZX4
4	16015-Z5T-901	CHAMBER SET, FLOAT	-	1	-	-	-	-----	QZA2, QZAV, QZN2, QZX4
5	16016-ZH7-W01	SCREW SET, PILOT	-	1	-	-	-	-----	QZA2, QZAV, QZN2, QZX4
6	16024-Z5T-901	SCREW SET, DRAIN	-	1	-	-	-	-----	QZA2, QZAV, QZN2, QZX4
7	16028-Z5T-901	SCREW SET	-	1	-	-	-	-----	QZA2, QZAV, QZN2, QZX4
8	16044-Z8T-W01	CHOKE SET	-	1	-	-	-	-----	QZA2, QZAV, QZN2, QZX4
9	16045-Z5T-W01	ARM, MANUAL START	-	1	-	-	-	-----	QZA2, QZAV, QZN2, QZX4
10	16100-Z8T-W01	CARBURETOR ASSY.(BE91A A)	-	1	-	-	-	1010607	QZA2, QZAV, QZN2, QZX4
	16100-Z8T-W02		-	1	-	-	-	1010608	QZA2, QZAV, QZN2, QZX4
11	16110-Z8T-W01	CARBURETOR SET	-	1	-	-	-	1010607	QZA2, QZAV, QZN2, QZX4
	16110-Z8T-W02		-	1	-	-	-	1010608	QZA2, QZAV, QZN2, QZX4
12	16111-Z5T-W01	GEAR, MIDDLE	-	1	-	-	-	-----	QZA2, QZAV, QZN2, QZX4
13	16112-Z5T-W01	ARM, CHOKE	-	1	-	-	-	-----	QZA2, QZAV, QZN2, QZX4
14	16113-Z5T-W01	LEVER, CHOKE CONTROL	-	1	-	-	-	-----	QZA2, QZAV, QZN2, QZX4
15	16115-Z5T-W01	PLATE	-	1	-	-	-	-----	QZA2, QZAV, QZN2, QZX4
16	16116-Z5T-W01	SPRING, TORSION COIL	-	1	-	-	-	-----	QZA2, QZAV, QZN2, QZX4
17	16117-Z5T-W01	CLIP, SPECIAL	-	1	-	-	-	-----	QZA2, QZAV, QZN2, QZX4
18	16118-Z5T-W01	CLIP, SPECIAL	-	1	-	-	-	-----	QZA2, QZAV, QZN2, QZX4
19	16119-Z5T-W01	SCREW SET	-	2	-	-	-	-----	QZA2, QZAV, QZN2, QZX4
20	16124-Z5T-W01	SCREW, STOP	-	1	-	-	-	-----	QZA2, QZAV, QZN2, QZX4
21	16166-Z8T-W01	NOZZLE, MAIN	-	1	-	-	-	-----	QZA2, QZAV, QZN2, QZX4
22	16173-001-004	O-RING	-	1	-	-	-	-----	QZA2, QZAV, QZN2, QZX4
23	16178-ZJ0-911	O-RING, 4.8X1.9	-	1	-	-	-	-----	QZA2, QZAV, QZN2, QZX4

E-14-2

CARBURETOR(3)

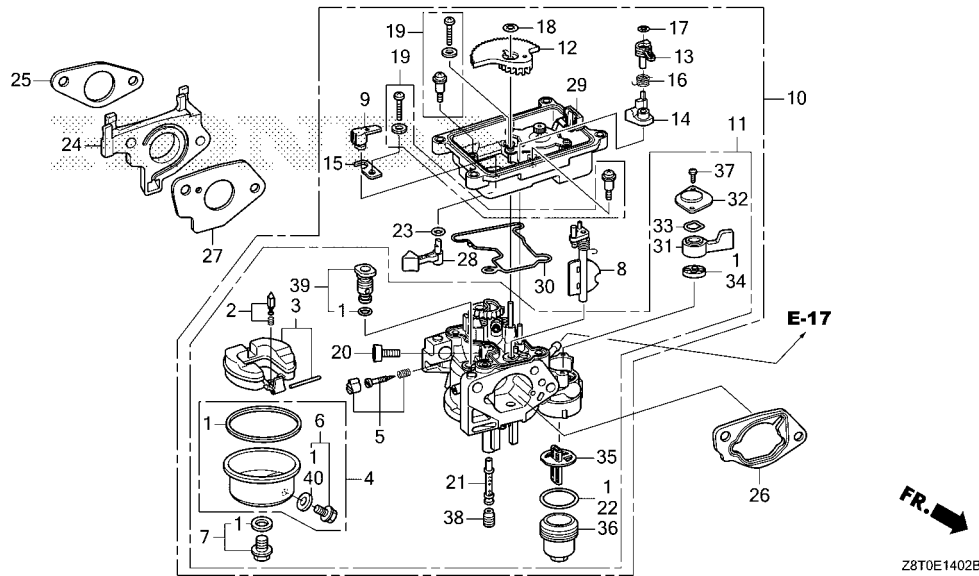

Ref. No.	Part No.	Description	Reqd. QTY					Serial No.	Parts catalogue code
			GX 340 UT1	GX 340 UT2	GX 340 RT1	GX 340 RT2	GX 340 UT2X		
24	16211-Z8T-W00	INSULATOR, CARBURETOR	-	1	-	-	-	----- QZA2, QZAV, QZN2, QZX4	
25	16212-Z5T-000	PACKING, CARBURETOR INSULATOR	-	1	-	-	-	----- QZA2, QZAV, QZN2, QZX4	
26	16220-ZA0-702	SPACER COMP., CARBURETOR	-	1	-	-	-	----- QZA2, QZAV, QZN2, QZX4	
27	16221-Z8T-000	PACKING, CARBURETOR	-	1	-	-	-	----- QZA2, QZAV, QZN2, QZX4	
28	16612-Z5T-W01	LEVER, MANUAL START	-	1	-	-	-	----- QZA2, QZAV, QZN2, QZX4	
29	16646-Z5T-W01	CASE COMP., MOTOR	-	1	-	-	-	----- QZA2, QZAV, QZN2, QZX4	
30	16648-Z5T-W01	U-RING	-	1	-	-	-	----- QZA2, QZAV, QZN2, QZX4	
31	16953-ZE1-812	LEVER, COCK	-	1	-	-	-	----- QZA2, QZAV, QZN2, QZX4	
32	16954-ZE1-812	PLATE, LEVER SETTING	-	1	-	-	-	----- QZA2, QZAV, QZN2, QZX4	
33	16956-ZE1-811	SPRING, COCK LEVER	-	1	-	-	-	----- QZA2, QZAV, QZN2, QZX4	
34	16957-ZE1-812	PACKING, FUEL COCK	-	1	-	-	-	----- QZA2, QZAV, QZN2, QZX4	
35	16959-Z5T-901	FILTER, CUP	-	1	-	-	-	----- QZA2, QZAV, QZN2, QZX4	
36	16967-ZE0-811	CUP, FUEL STRAINER	-	1	-	-	-	----- QZA2, QZAV, QZN2, QZX4	
37	93500-03006-1H	SCREW, PAN, 3X6	-	2	-	-	-	----- QZA2, QZAV, QZN2, QZX4	
38	99101-ZH8-0880	JET, MAIN, #88	-	(1)	-	-	-	----- QZA2, QZAV, QZN2, QZX4	
	99101-ZH8-0920	JET, MAIN, #92	-	(1)	-	-	-	----- QZA2, QZAV, QZN2, QZX4	
	99101-ZH8-0980	JET, MAIN, #98	-	1	-	-	1010607	----- QZA2, QZAV, QZN2, QZX4	
	99101-ZH8-0950	JET, MAIN, #95	-	1	-	-	1010608	----- QZA2, QZAV, QZN2, QZX4	
39	99204-ZE2-0380	JET SET, PILOT, #38	-	1	-	-	-	----- QZA2, QZAV, QZN2, QZX4	
40	16141-Z0S-003	WASHER, PLAIN(6.2X10.7 DRAIN)	-	1	-	-	-	----- QZA2, QZAV, QZN2, QZX4	



E-15

AIR CLEANER(1)

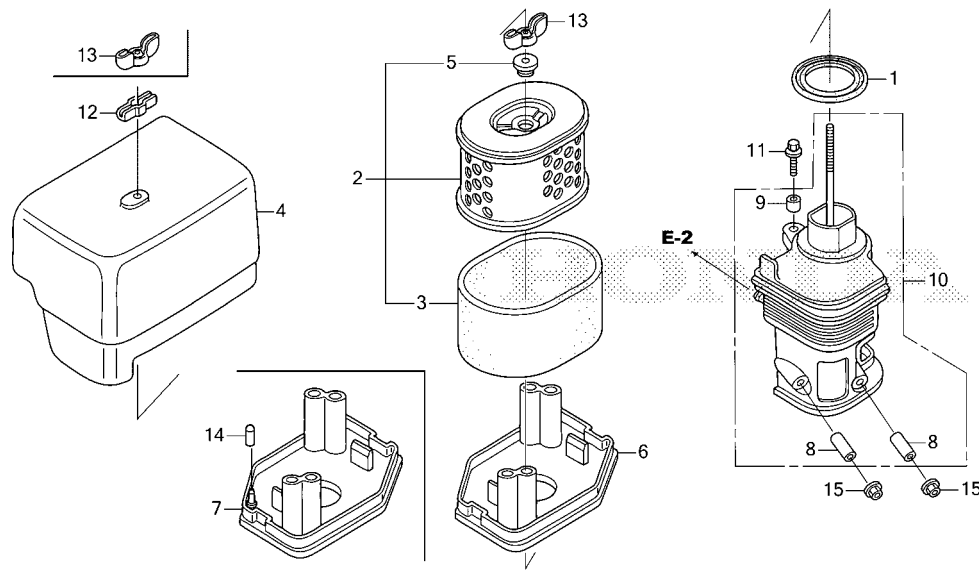

Ref. L.O.N. (Relative ref. Number) F.R.T.
 No. Description

Ref. No.	Part No.	Description	Reqd. QTY					Serial No.	Parts catalogue code
			GX 340 UT1	GX 340 UT2	GX 340 RT1	GX 340 RT2	GX 340 UT2X		
1	16271-ZE2-010	PACKING, ELBOW	1	-	1	-	-	HA2, HX26, LX2, LXE4, LXE8, LXQ4, LXU, PKT2, QA2, QA26, QAE2, QAE6 QAG, QAH2, QAP2, QE, QHB4, QHQ4, QKA4, QNB2, QNE2, QNR2, QNR6, QXB7 QXB9, QXE4, QXE6, QXE8, QXQ4, QXU, SE, SHQ4, SME0, SXE4, SXE8, SXQ4 VA2, VAD2, VDE2, VW12, VWE2, VX16, VX8, VXB7, VXB9, VXE2, VXE7, VXE8 VXE9	
2	17210-ZE3-010	ELEMENT, AIR CLEANER	1	-	1	-	-	HA2, HX26, LX2, LXE4, LXE8, LXQ4, LXU, PKT2, QA2, QA26, QAE2, QAE6 QAG, QAH2, QAP2, QE, QHB4, QHQ4, QKA4, QNB2, QNE2, QNR2, QNR6, QXB7 QXB9, QXE4, QXE6, QXE8, QXQ4, QXU, SE, SHQ4, SME0, SXE4, SXE8, SXQ4 VA2, VAD2, VDE2, VW12, VWE2, VX16, VX8, VXB7, VXB9, VXE2, VXE7, VXE8 VXE9	
3	17218-ZE3-000	FILTER, OUTER	1	-	1	-	-	HA2, HX26, LX2, LXE4, LXE8, LXQ4, LXU, PKT2, QA2, QA26, QAE2, QAE6 QAG, QAH2, QAP2, QE, QHB4, QHQ4, QKA4, QNB2, QNE2, QNR2, QNR6, QXB7 QXB9, QXE4, QXE6, QXE8, QXQ4, QXU, SE, SHQ4, SME0, SXE4, SXE8, SXQ4 VA2, VAD2, VDE2, VW12, VWE2, VX16, VX8, VXB7, VXB9, VXE2, VXE7, VXE8 VXE9	
4	17231-ZE3-W01	COVER, AIR CLEANER	1	-	1	-	-	HA2, HX26, LX2, LXE4, LXE8, LXQ4, LXU, PKT2, QA2, QA26, QAE2, QAE6 QAG, QAH2, QAP2, QE, QHB4, QHQ4, QKA4, QNB2, QNE2, QNR2, QNR6, QXB7 QXB9, QXE4, QXE6, QXE8, QXQ4, QXU, SE, SHQ4, SME0, SXE4, SXE8, SXQ4 VA2, VAD2, VDE2, VW12, VWE2, VX16, VX8, VXB7, VXB9, VXE2, VXE7, VXE8 VXE9	
5	17232-891-000	GROMMET, AIR CLEANER	1	-	1	-	-	HA2, HX26, LX2, LXE4, LXE8, LXQ4, LXU, PKT2, QA2, QA26, QAE2, QAE6 QAG, QAH2, QAP2, QE, QHB4, QHQ4, QKA4, QNB2, QNE2, QNR2, QNR6, QXB7 QXB9, QXE4, QXE6, QXE8, QXQ4, QXU, SE, SHQ4, SME0, SXE4, SXE8, SXQ4 VA2, VAD2, VDE2, VW12, VWE2, VX16, VX8, VXB7, VXB9, VXE2, VXE7, VXE8 VXE9	

E-15

AIR CLEANER(1)

Ref. No.	Part No.	Description	Reqd. QTY					Serial No.	Parts catalogue code
			GX 340 UT1	GX 340 UT2	GX 340 RT1	GX 340 RT2	GX 340 UT2X		
6	17235-ZH9-N01	NOSE, SILENCER	1	-	-	-	-	HA2, HX26, LX2, LXE4, LXE8, LXQ4, LXU, PKT2, QA2, QA26, QAE2, QAE6 QAG, QAH2, QAP2, QE, QHB4, QHQ4, QKA4, QNE2, QNR2, QNR6, QXB7, QXB9 QXE4, QXE6, QXE8, QXQ4, QXU, SE, SHQ4, SME0, SXE4, SXE8, SXQ4, VA2 VX16, VX8, VXB7, VXB9, VXE2, VXE7, VXE8, VXE9	
7	17235-Z5R-800	NOSE, SILENCER	-	-	1	-	-	QNB2, VAD2, VDE2, VW12, VWE2	
8	17238-ZE2-310	COLLAR, AIR CLEANER	2	-	2	-	-	HA2, HX26, LX2, LXE4, LXE8, LXQ4, LXU, PKT2, QA2, QA26, QAE2, QAE6 QAG, QAH2, QAP2, QE, QHB4, QHQ4, QKA4, QNB2, QNE2, QNR2, QNR6, QXB7 QXB9, QXE4, QXE6, QXE8, QXQ4, QXU, SE, SHQ4, SME0, SXE4, SXE8, SXQ4 VA2, VAD2, VDE2, VW12, VWE2, VX16, VX8, VXB7, VXB9, VXE2, VXE7, VXE8 VXE9	
9	17239-ZE1-000	COLLAR B, AIR CLEANER	1	-	1	-	-	HA2, HX26, LX2, LXE4, LXE8, LXQ4, LXU, PKT2, QA2, QA26, QAE2, QAE6 QAG, QAH2, QAP2, QE, QHB4, QHQ4, QKA4, QNB2, QNE2, QNR2, QNR6, QXB7 QXB9, QXE4, QXE6, QXE8, QXQ4, QXU, SE, SHQ4, SME0, SXE4, SXE8, SXQ4 VA2, VAD2, VDE2, VW12, VWE2, VX16, VX8, VXB7, VXB9, VXE2, VXE7, VXE8 VXE9	
10	17410-ZH9-N00	ELBOW COMP., AIR CLEANER	1	-	1	-	-	HA2, HX26, LX2, LXE4, LXE8, LXQ4, LXU, PKT2, QA2, QA26, QAE2, QAE6 QAG, QAH2, QAP2, QE, QHB4, QHQ4, QKA4, QNB2, QNE2, QNR2, QNR6, QXB7 QXB9, QXE4, QXE6, QXE8, QXQ4, QXU, SE, SHQ4, SME0, SXE4, SXE8, SXQ4 VA2, VAD2, VDE2, VW12, VWE2, VX16, VX8, VXB7, VXB9, VXE2, VXE7, VXE8 VXE9	
11	90009-ZE2-003	BOLT-WASHER, 6X22	1	-	-	-	-	1000009 HA2, HX26, LX2, LXE4, LXE8, LXQ4, LXU, PKT2, QA2, QA26, QAE2, QAE6 QAG, QAH2, QAP2, QE, QHB4, QHQ4, QKA4, QNE2, QNR2, QNR6, QXB7, QXB9 QXE4, QXE6, QXE8, QXQ4, QXU, SE, SHQ4, SME0, SXE4, SXE8, SXQ4, VA2 VX16, VX8, VXB7, VXB9, VXE2, VXE7, VXE8, VXE9	
	90009-Z1C-000	1	-	-	-	-	1000010 HA2, HX26, LX2, LXE4, LXE8, LXQ4, LXU, PKT2, QA2, QA26, QAE2, QAE6 QAG, QAH2, QAP2, QE, QHB4, QHQ4, QKA4, QNE2, QNR2, QNR6, QXB7, QXB9 QXE4, QXE6, QXE8, QXQ4, QXU, SE, SHQ4, SME0, SXE4, SXE8, SXQ4, VA2 VX16, VX8, VXB7, VXB9, VXE2, VXE7, VXE8, VXE9	
	90009-ZE2-003	-	-	1	-	-	1000737 QNB2, VAD2, VDE2, VW12, VWE2	
	90009-Z1C-000	-	-	1	-	-	1000738 QNB2, VAD2, VDE2, VW12, VWE2	
12	90203-ZA0-800	NUT, WING, 6MM(BLACK)	1	-	-	-	-	HA2, HX26, LX2, QA2, QA26, QAE2, QAE6, QAG, QAH2, QAP2, QNE2, QXE6 VA2, VXE2	
13	90325-044-000	NUT, TOOL BOX SETTING	1	-	-	-	-	HA2, HX26, LX2, QA2, QA26, QAE2, QAE6, QAG, QAH2, QAP2, QNE2, QXE6 VA2, VXE2	
			2	-	-	-	-	LXE4, LXE8, LXQ4, LXU, PKT2, QE, QHB4, QHQ4, QKA4, QNR2, QNR6, QXB7 QXB9, QXE4, QXE8, QXQ4, QXU, SE, SHQ4, SME0, SXE4, SXE8, SXQ4, VX16 VX8, VXB7, VXB9, VXE7, VXE8, VXE9	
			-	-	2	-	-	QNB2, VAD2, VDE2, VW12, VWE2	
14	90634-ZL8-H00	CAP, SEALING	-	-	1	-	-	QNB2, VAD2, VDE2, VW12, VWE2	
15	94050-06000	NUT, FLANGE, 6MM	2	-	2	-	-	HA2, HX26, LX2, LXE4, LXE8, LXQ4, LXU, PKT2, QA2, QA26, QAE2, QAE6 QAG, QAH2, QAP2, QE, QHB4, QHQ4, QKA4, QNB2, QNE2, QNR2, QNR6, QXB7 QXB9, QXE4, QXE6, QXE8, QXQ4, QXU, SE, SHQ4, SME0, SXE4, SXE8, SXQ4 VA2, VAD2, VDE2, VW12, VWE2, VX16, VX8, VXB7, VXB9, VXE2, VXE7, VXE8 VXE9	



E-15-1

AIR CLEANER(2)

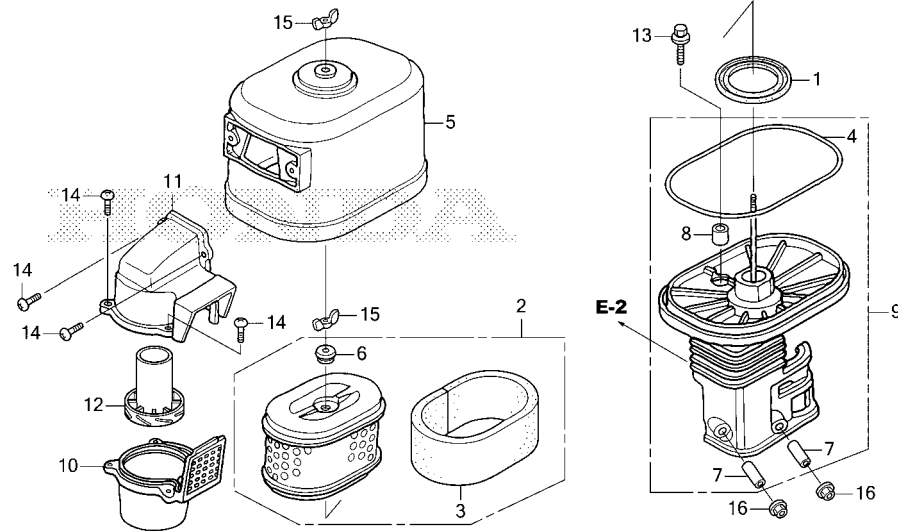

FR. →
Z8T0E1501A

Ref. No. L.O.N. (Relative ref. Number) Description F.R.T.

Ref. No.	Part No.	Description	Reqd. QTY					Serial No.	Parts catalogue code	
			GX 340 UT1	GX 340 UT2	GX 340 RT1	GX 340 RT2	GX 340 UT2X			
1	16271-ZE2-010	PACKING, ELBOW.....	1	1	-	-	-	-----	QDW9, QXC4, QXC6, QXC9	
2	17210-ZE3-010	ELEMENT, AIR CLEANER.....	1	1	-	-	-	-----	QDW9, QXC4, QXC6, QXC9	
3	17218-ZE3-000	FILTER, OUTER.....	1	1	-	-	-	-----	QDW9, QXC4, QXC6, QXC9	
4	17219-ZE3-840	PACKING, AIR CLEANER COVER...	1	1	-	-	-	-----	QDW9, QXC4, QXC6, QXC9	
5	17230-ZE3-841	COVER COMP., AIR CLEANER (CYCLONE)	1	1	-	-	-	-----	QDW9, QXC4, QXC6, QXC9	
6	17232-891-000	GROMMET, AIR CLEANER.....	1	1	-	-	-	-----	QDW9, QXC4, QXC6, QXC9	
7	17238-ZE2-310	COLLAR, AIR CLEANER.....	2	2	-	-	-	-----	QDW9, QXC4, QXC6, QXC9	
8	17239-ZE3-840	COLLAR B, AIR CLEANER.....	1	1	-	-	-	-----	QDW9, QXC4, QXC6, QXC9	
9	17410-ZE3-840	ELBOW COMP., AIR CLEANER.....	1	-	-	-	-	-----	QDW9, QXC4, QXC6, QXC9	
	17410-ZE3-841	-	1	-	-	-	-----	QDW9, QXC9	
10	17470-ZE3-842	CASE COMP., PRE AIR CLEANER..	1	1	-	-	-	-----	QDW9, QXC4, QXC6, QXC9	
11	17475-ZE3-841	CAP, PRE AIR CLEANER.....	1	1	-	-	-	-----	QDW9, QXC4, QXC6, QXC9	
12	17476-ZE3-841	GUIDE, PRE AIR CLEANER.....	1	1	-	-	-	-----	QDW9, QXC4, QXC6, QXC9	
13	90009-ZE2-003	BOLT-WASHER, 6X22.....	1	-	-	-	-	1000009	-----	QDW9, QXC4, QXC6, QXC9
	90009-Z1C-000	1	-	-	-	-	1000010	-----	QDW9, QXC4, QXC6, QXC9
			-	1	-	-	-	-	-----	QDW9, QXC9
14	90142-MB0-000	SCREW, PAN, 5X16.5.....	5	5	-	-	-	-----	QDW9, QXC4, QXC6, QXC9	
15	90325-044-000	NUT, TOOL BOX SETTING.....	2	2	-	-	-	-----	QDW9, QXC4, QXC6, QXC9	
16	94050-06000	NUT, FLANGE, 6MM.....	2	2	-	-	-	-----	QDW9, QXC4, QXC6, QXC9	

E-15-2

AIR CLEANER(3)

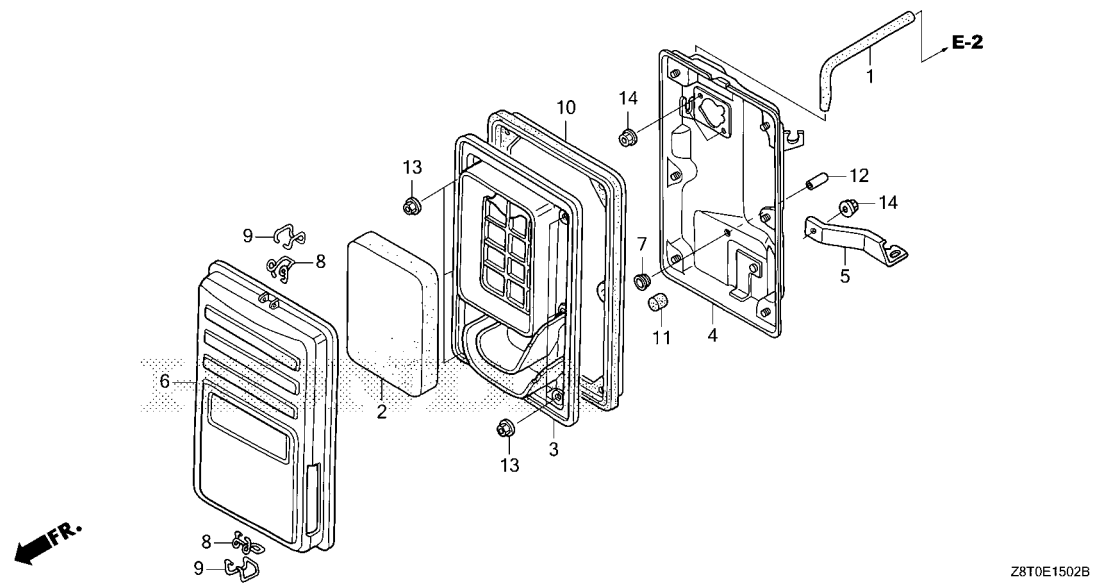

Ref. L.O.N. (Relative ref. Number) F.R.T.
 No. Description

Ref. No.	Part No.	Description	Reqd. QTY					Serial No.	Parts catalogue code
			GX 340 UT1	GX 340 UT2	GX 340 RT1	GX 340 RT2	GX 340 UT2X		
1	15721-ZB4-000	TUBE, BREATHER	-	-	1	-	-	VC2, VWC, VWE	
2	17211-899-000	ELEMENT, AIR CLEANER	-	-	1	-	-	VC2, VWC, VWE	
3	17212-Z5R-000	SEPARATOR, AIR CLEANER	-	-	1	-	-	VC2, VWC, VWE	
4	17220-Z5R-000	CASE COMP., AIR CLEANER	-	-	1	-	-	VC2, VWC, VWE	
5	17222-ZC2-000	STAY, AIR CLEANER	-	-	1	-	-	VC2, VWC, VWE	
6	17231-899-000	COVER COMP., AIR CLEANER	-	-	1	-	-	VC2, VWC, VWE	
7	17232-898-000	GROMMET, AIR CLEANER	-	-	1	-	-	VC2, VWC, VWE	
8	17235-899-000	CLIP A, AIR CLEANER WIRE	-	-	2	-	-	VC2, VWC, VWE	
9	17236-899-000	CLIP B, AIR CLEANER WIRE	-	-	2	-	-	VC2, VWC, VWE	
10	17252-899-000	SEAL, AIR CLEANER	-	-	1	-	-	VC2, VWC, VWE	
11	17367-413-690	FILTER, DRAIN TUBE	-	-	1	-	-	VC2, VWC, VWE	
12	90634-ZL8-H00	CAP, SEALING	-	-	1	-	-	VC2, VWC, VWE	
13	94050-05000	NUT, FLANGE, 5MM	-	-	6	-	-	VC2, VWC, VWE	
14	94050-06000	NUT, FLANGE, 6MM	-	-	3	-	-	VC2, VWC, VWE	



E-15-3

AIR CLEANER(4)

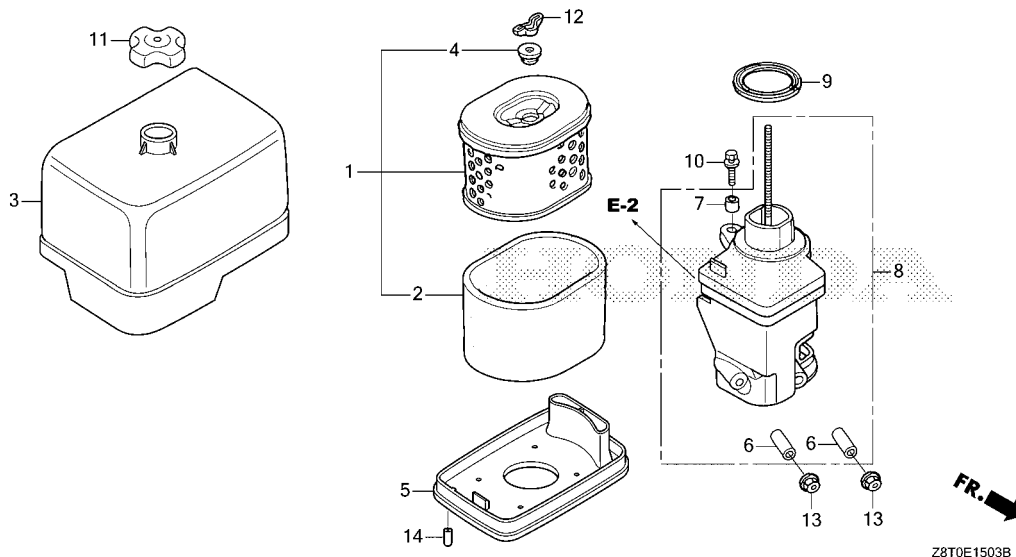

Ref. L.O.N. (Relative ref. Number) F.R.T.
No. Description

Ref. No.	Part No.	Description	Reqd. QTY					Serial No.	Parts catalogue code
			GX 340 UT1	GX 340 UT2	GX 340 RT1	GX 340 RT2	GX 340 UT2X		
1	17210-ZE3-010	ELEMENT, AIR CLEANER.....	-	1	-	1	1	-----	HA2, HA2/A, HX26, HX26/A, LX2, LXE4, LXQ4, LXQ4/A, LXU, PKT2, PKT2/A, PKX2, PKX2/A, QA2, QA2/A, QAE2, QAE2/A, QAE6, QAE6/A, QAG, QAH2, QAH2/A, QAP2, QAP2/A, QE, QE/A, QHB4, QHB4/A, QHQ4, QKA4, QKA4/A, QMT2, QMT2/A, QNB2, QNE2, QNE2/A, QNR2, QNR2/A, QWC, QWC/A, QXB7, QXB7/A, QXB9, QXE4, QXE4/A, QXE6, QXE8, QXQ4, QXQ4/A, QXU, QXU/A, SE, SE/A, SE1, SE2, SHQ4, SHQ4/A, SME0, SME0/A, SMX2, SXE4, SXE4/A, SXE8, SXQ4, SXQ4/A, VA2, VDE2, VWE2, VWE2/A, VX16, VX16/A, VX8, VX8/A, VXB7, VXB9, VXE2, VXE2/A, VXE8, VXE8/A, VXE9
	17210-Z5T-W00	ELEMENT COMP., AIR CLEANER...	-	1	-	-	-	-----	QZA2, QZAV, QZN2, QZX4
2	17218-ZE3-000	FILTER, OUTER.....	-	1	-	1	1	-----	HA2, HA2/A, HX26, HX26/A, LX2, LXE4, LXQ4, LXQ4/A, LXU, PKT2, PKT2/A, PKX2, PKX2/A, QA2, QA2/A, QAE2, QAE2/A, QAE6, QAE6/A, QAG, QAH2, QAH2/A, QAP2, QAP2/A, QE, QE/A, QHB4, QHB4/A, QHQ4, QKA4, QKA4/A, QMT2, QMT2/A, QNB2, QNE2, QNE2/A, QNR2, QNR2/A, QWC, QWC/A, QXB7, QXB7/A, QXB9, QXE4, QXE4/A, QXE6, QXE8, QXQ4, QXQ4/A, QXU, QXU/A, QZA2, QZAV, QZN2, QZX4, SE, SE/A, SE1, SE2, SHQ4, SHQ4/A, SME0, SME0/A, SMX2, SXE4, SXE4/A, SXE8, SXQ4, SXQ4/A, VA2, VDE2, VWE2, VWE2/A, VX16, VX16/A, VX8, VX8/A, VXB7, VXB9, VXE2, VXE2/A, VXE8, VXE8/A, VXE9
3	17231-Z5T-000	COVER, AIR CLEANER CASE.....	-	1	-	1	1	-----	HA2, HA2/A, HX26, HX26/A, LX2, LXE4, LXQ4, LXQ4/A, LXU, PKT2, PKT2/A, PKX2, PKX2/A, QA2, QA2/A, QAE2, QAE2/A, QAE6, QAE6/A, QAG, QAH2, QAH2/A, QAP2, QAP2/A, QE, QE/A, QHB4, QHB4/A, QHQ4, QKA4, QKA4/A, QMT2, QMT2/A, QNB2, QNE2, QNE2/A, QNR2, QNR2/A, QWC, QWC/A, QXB7, QXB7/A, QXB9, QXE4, QXE4/A, QXE6, QXE8, QXQ4, QXQ4/A, QXU, QXU/A, QZA2, QZAV, QZN2, QZX4, SE, SE/A, SE1, SE2, SHQ4, SHQ4/A, SME0, SME0/A, SMX2, SXE4, SXE4/A, SXE8, SXQ4, SXQ4/A, VA2, VDE2, VWE2, VWE2/A, VX16, VX16/A, VX8, VX8/A, VXB7, VXB9, VXE2, VXE2/A, VXE8, VXE8/A, VXE9

E-15-3

AIR CLEANER(4)

Ref. No.	Part No.	Description	Reqd. QTY					Serial No.	Parts catalogue code
			GX 340 UT1	GX 340 UT2	GX 340 RT1	GX 340 RT2	GX 340 UT2X		
4	17232-891-000	GROMMET, AIR CLEANER.....	-	1	-	1	1	-----	HA2, HA2/A, HX26, HX26/A, LX2, LXE4, LXQ4, LXQ4/A, LXU, PKT2, PKT2/A, PKX2, PKX2/A, QA2, QA2/A, QAE2, QAE2/A, QAE6, QAE6/A, QAG, QAH2, QAH2/A, QAP2, QAP2/A, QE, QE/A, QHB4, QHB4/A, QHQ4, QKA4, QKA4/A, QMT2, QMT2/A, QNB2, QNE2, QNE2/A, QNR2, QNR2/A, QWC, QWC/A, QXB7, QXB7/A, QXB9, QXE4, QXE4/A, QXE6, QXE8, QXQ4, QXQ4/A, QXU, QXU/A, QZA2, QZAV, QZN2, QZX4, SE, SE/A, SE1, SE2, SHQ4, SHQ4/A, SME0, SME0/A, SMX2, SXE4, SXE4/A, SXE8, SXQ4, SXQ4/A, VA2, VDE2, VWE2, VWE2/A, VX16, VX16/A, VX8, VX8/A, VXB7, VXB9, VXE2, VXE2/A, VXE8, VXE8/A, VXE9
5	17235-Z5T-000	NOSE, SILENCER.....	-	1	-	-	1	-----	HA2, HA2/A, HX26, HX26/A, LX2, LXE4, LXQ4, LXQ4/A, LXU, PKT2, PKT2/A, PKX2, PKX2/A, QA2, QA2/A, QAE2, QAE2/A, QAE6, QAE6/A, QAG, QAH2, QAH2/A, QAP2, QAP2/A, QE, QE/A, QHB4, QHB4/A, QHQ4, QKA4, QKA4/A, QMT2, QMT2/A, QNE2, QNE2/A, QNR2, QNR2/A, QWC, QWC/A, QXB7, QXB7/A, QXB9, QXE4, QXE4/A, QXE6, QXE8, QXQ4, QXQ4/A, QXU, QXU/A, QZA2, QZAV, QZN2, QZX4, SE, SE/A, SE1, SE2, SHQ4, SHQ4/A, SME0, SME0/A, SMX2, SXE4, SXE4/A, SXE8, SXQ4, SXQ4/A, VA2, VX16, VX16/A, VX8, VX8/A, VXB7, VXB9, VXE2, VXE2/A, VXE8, VXE8/A, VXE9
	17235-Z5T-800	-	-	-	1	-	-----	QNB2, VDE2, VWE2, VWE2/A
6	17238-ZE2-310	COLLAR, AIR CLEANER.....	-	2	-	2	2	-----	HA2, HA2/A, HX26, HX26/A, LX2, LXE4, LXQ4, LXQ4/A, LXU, PKT2, PKT2/A, PKX2, PKX2/A, QA2, QA2/A, QAE2, QAE2/A, QAE6, QAE6/A, QAG, QAH2, QAH2/A, QAP2, QAP2/A, QE, QE/A, QHB4, QHB4/A, QHQ4, QKA4, QKA4/A, QMT2, QMT2/A, QNB2, QNE2, QNE2/A, QNR2, QNR2/A, QWC, QWC/A, QXB7, QXB7/A, QXB9, QXE4, QXE4/A, QXE6, QXE8, QXQ4, QXQ4/A, QXU, QXU/A, QZA2, QZAV, QZN2, QZX4, SE, SE/A, SE1, SE2, SHQ4, SHQ4/A, SME0, SME0/A, SMX2, SXE4, SXE4/A, SXE8, SXQ4, SXQ4/A, VA2, VDE2, VWE2, VWE2/A, VX16, VX16/A, VX8, VX8/A, VXB7, VXB9, VXE2, VXE2/A, VXE8, VXE8/A, VXE9
7	17239-ZE1-000	COLLAR B, AIR CLEANER.....	-	1	-	1	1	-----	HA2, HA2/A, HX26, HX26/A, LX2, LXE4, LXQ4, LXQ4/A, LXU, PKT2, PKT2/A, PKX2, PKX2/A, QA2, QA2/A, QAE2, QAE2/A, QAE6, QAE6/A, QAG, QAH2, QAH2/A, QAP2, QAP2/A, QE, QE/A, QHB4, QHB4/A, QHQ4, QKA4, QKA4/A, QMT2, QMT2/A, QNB2, QNE2, QNE2/A, QNR2, QNR2/A, QWC, QWC/A, QXB7, QXB7/A, QXB9, QXE4, QXE4/A, QXE6, QXE8, QXQ4, QXQ4/A, QXU, QXU/A, QZA2, QZAV, QZN2, QZX4, SE, SE/A, SE1, SE2, SHQ4, SHQ4/A, SME0, SME0/A, SMX2, SXE4, SXE4/A, SXE8, SXQ4, SXQ4/A, VA2, VDE2, VWE2, VWE2/A, VX16, VX16/A, VX8, VX8/A, VXB7, VXB9, VXE2, VXE2/A, VXE8, VXE8/A, VXE9
8	17410-Z5T-020	ELBOW COMP., AIR CLEANER.....	-	1	-	1	1	-----	HA2, HA2/A, HX26, HX26/A, LX2, LXE4, LXQ4, LXQ4/A, LXU, PKT2, PKT2/A, PKX2, PKX2/A, QA2, QA2/A, QAE2, QAE2/A, QAE6, QAE6/A, QAG, QAH2, QAH2/A, QAP2, QAP2/A, QE, QE/A, QHB4, QHB4/A, QHQ4, QKA4, QKA4/A, QMT2, QMT2/A, QNB2, QNE2, QNE2/A, QNR2, QNR2/A, QWC, QWC/A, QXB7, QXB7/A, QXB9, QXE4, QXE4/A, QXE6, QXE8, QXQ4, QXQ4/A, QXU, QXU/A, SE, SE/A, SE1, SE2, SHQ4, SHQ4/A, SME0, SME0/A, SMX2, SXE4, SXE4/A, SXE8, SXQ4, SXQ4/A, VA2, VDE2, VWE2, VWE2/A, VX16, VX16/A, VX8, VX8/A, VXB7, VXB9, VXE2, VXE2/A, VXE8, VXE8/A, VXE9
	17410-Z5T-W00	-	1	-	-	-	-----	QZA2, QZAV, QZN2, QZX4
9	17417-Z5T-000	PACKING, AIR CLEANER CASE.....	-	1	-	1	1	-----	HA2, HA2/A, HX26, HX26/A, LX2, LXE4, LXQ4, LXQ4/A, LXU, PKT2, PKT2/A, PKX2, PKX2/A, QA2, QA2/A, QAE2, QAE2/A, QAE6, QAE6/A, QAG, QAH2, QAH2/A, QAP2, QAP2/A, QE, QE/A, QHB4, QHB4/A, QHQ4, QKA4, QKA4/A, QMT2, QMT2/A, QNB2, QNE2, QNE2/A, QNR2, QNR2/A, QWC, QWC/A, QXB7, QXB7/A, QXB9, QXE4, QXE4/A, QXE6, QXE8, QXQ4, QXQ4/A, QXU, QXU/A, QZA2, QZAV, QZN2, QZX4, SE, SE/A, SE1, SE2, SHQ4, SHQ4/A, SME0, SME0/A, SMX2, SXE4, SXE4/A, SXE8, SXQ4, SXQ4/A, VA2, VDE2, VWE2, VWE2/A, VX16, VX16/A, VX8, VX8/A, VXB7, VXB9, VXE2, VXE2/A, VXE8, VXE8/A, VXE9



E-15-3

AIR CLEANER(4)

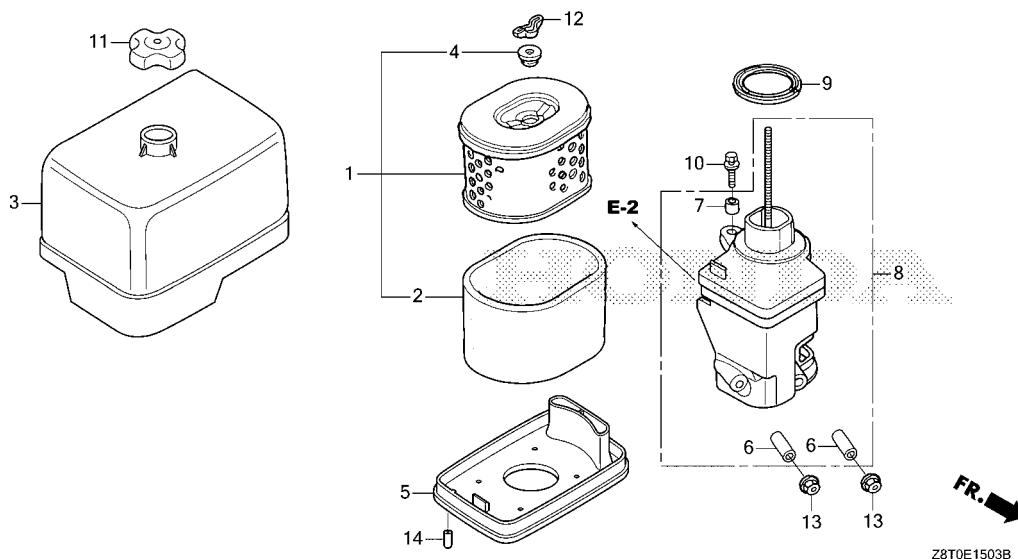

Ref. No.	Part No.	Description	Reqd. QTY					Serial No.	Parts catalogue code
			GX 340 UT1	GX 340 UT2	GX 340 RT1	GX 340 RT2	GX 340 UT2X		
10	90009-Z1C-000	BOLT-WASHER, 6X22	-	1	-	1	1	-----	HA2, HA2/A, HX26, HX26/A, LX2, LXE4, LXQ4, LXQ4/A, LXU, PKT2, PKT2/A, PKX2, PKX2/A, QA2, QA2/A, QAE2, QAE2/A, QAE6, QAE6/A, QAG, QAH2, QAH2/A, QAP2, QAP2/A, QE, QE/A, QHB4, QHB4/A, QHQ4, QKA4, QKA4/A, QMT2, QMT2/A, QNB2, QNE2, QNE2/A, QNR2, QNR2/A, QWC, QWC/A, QXB7, QXB7/A, QXB9, QXE4, QXE4/A, QXE6, QXE8, QXQ4, QXQ4/A, QXU, QXU/A, SE, SE/A, SE1, SE2, SHQ4, SHQ4/A, SME0, SME0/A, SMX2, SXE4/A, SXE8, SXQ4, SXQ4/A, VA2, VDE2, VWE2, VWE2/A, VX16, VX16/A, VX8, VX8/A, VXB7, VXB9, VXE2, VXE2/A, VXE8, VXE8/A, VXE9, QZA2, QZAV, QZN2, QZX4
	90009-Z5T-W00	BOLT-WASHER, 6X18	-	1	-	-	-	-----	
11	90202-Z2E-000	NUT, AIR CLEANER COVER	-	1	-	1	1	-----	HA2, HA2/A, HX26, HX26/A, LX2, LXE4, LXQ4, LXQ4/A, LXU, PKT2, PKT2/A, PKX2, PKX2/A, QA2, QA2/A, QAE2, QAE2/A, QAE6, QAE6/A, QAG, QAH2, QAH2/A, QAP2, QAP2/A, QE, QE/A, QHB4, QHB4/A, QHQ4, QKA4, QKA4/A, QMT2, QMT2/A, QNB2, QNE2, QNE2/A, QNR2, QNR2/A, QWC, QWC/A, QXB7, QXB7/A, QXB9, QXE4, QXE4/A, QXE6, QXE8, QXQ4, QXQ4/A, QXU, QXU/A, QZA2, QZAV, QZN2, QZX4, SE, SE/A, SE1, SE2, SHQ4, SHQ4/A, SME0, SME0/A, SMX2, SXE4, SXE4/A, SXE8, SXQ4, SXQ4/A, VA2, VDE2, VWE2, VWE2/A, VX16, VX16/A, VX8, VX8/A, VXB7, VXB9, VXE2, VXE2/A, VXE8, VXE8/A, VXE9
12	90325-044-000	NUT, TOOL BOX SETTING	-	1	-	1	1	-----	HA2, HA2/A, HX26, HX26/A, LX2, LXE4, LXQ4, LXQ4/A, LXU, PKT2, PKT2/A, PKX2, PKX2/A, QA2, QA2/A, QAE2, QAE2/A, QAE6, QAE6/A, QAG, QAH2, QAH2/A, QAP2, QAP2/A, QE, QE/A, QHB4, QHB4/A, QHQ4, QKA4, QKA4/A, QMT2, QMT2/A, QNB2, QNE2, QNE2/A, QNR2, QNR2/A, QWC, QWC/A, QXB7, QXB7/A, QXB9, QXE4, QXE4/A, QXE6, QXE8, QXQ4, QXQ4/A, QXU, QXU/A, QZA2, QZAV, QZN2, QZX4, SE, SE/A, SE1, SE2, SHQ4, SHQ4/A, SME0, SME0/A, SMX2, SXE4, SXE4/A, SXE8, SXQ4, SXQ4/A, VA2, VDE2, VWE2, VWE2/A, VX16, VX16/A, VX8, VX8/A, VXB7, VXB9, VXE2, VXE2/A, VXE8, VXE8/A, VXE9

E-15-3

AIR CLEANER(4)

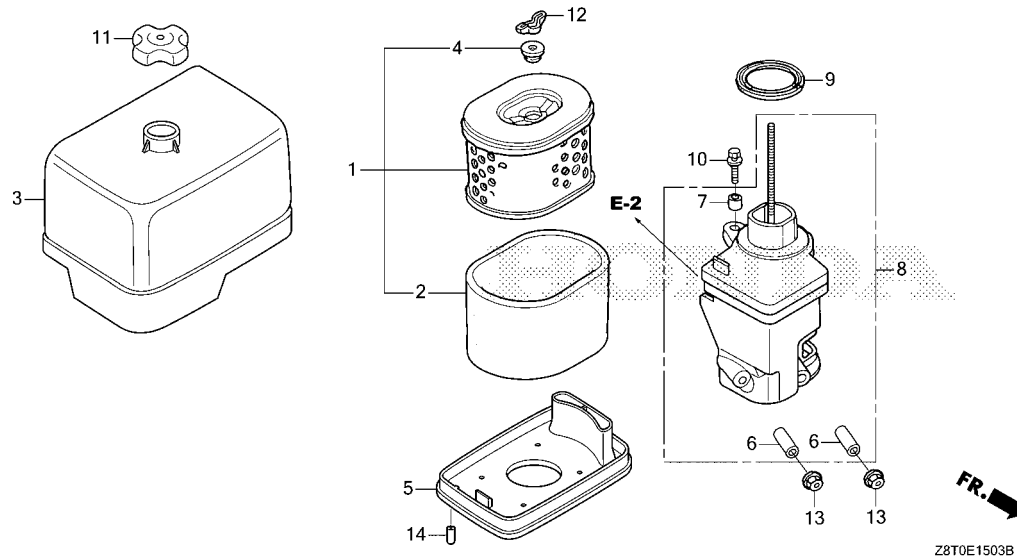

Ref. No.	Part No.	Description	Reqd. QTY					Serial No.	Parts catalogue code
			GX 340 UT1	GX 340 UT2	GX 340 RT1	GX 340 RT2	GX 340 UT2X		
13	94050-06000	NUT, FLANGE, 6MM.....	-	2	-	2	2	-----	HA2, HA2/A, HX26, HX26/A, LX2, LXE4, LXQ4, LXQ4/A, LXU, PKT2, PKT2/A, PKX2, PKX2/A, QA2, QA2/A, QAE2, QAE2/A, QAE6, QAE6/A, QAG, QAH2, QAH2/A, QAP2, QAP2/A, QE, QE/A, QHB4, QHB4/A, QHQ4, QKA4, QKA4/A, QMT2, QMT2/A, QNB2, QNE2, QNE2/A, QNR2, QNR2/A, QWC, QWC/A, QXB7, QXB7/A, QXB9, QXE4, QXE4/A, QXE6, QXE8, QXQ4, QXQ4/A, QXU, QXU/A, QZA2, QZAV, QZN2, QZX4, SE, SE/A, SE1, SE2, SHQ4, SHQ4/A, SME0, SME0/A, SMX2, SXE4, SXE4/A, SXE8, SXQ4, SXQ4/A, VA2, VDE2, VWE2, VWE2/A, VX16, VX16/A, VX8, VX8/A, VXB7, VXB9, VXE2, VXE2/A, VXE8, VXE8/A, VXE9
14	90634-ZL8-H00	CAP, SEALING.....	-	-	-	1	-	-----	QNB2, VDE2, VWE2, VWE2/A



E-15-4

AIR CLEANER(5)

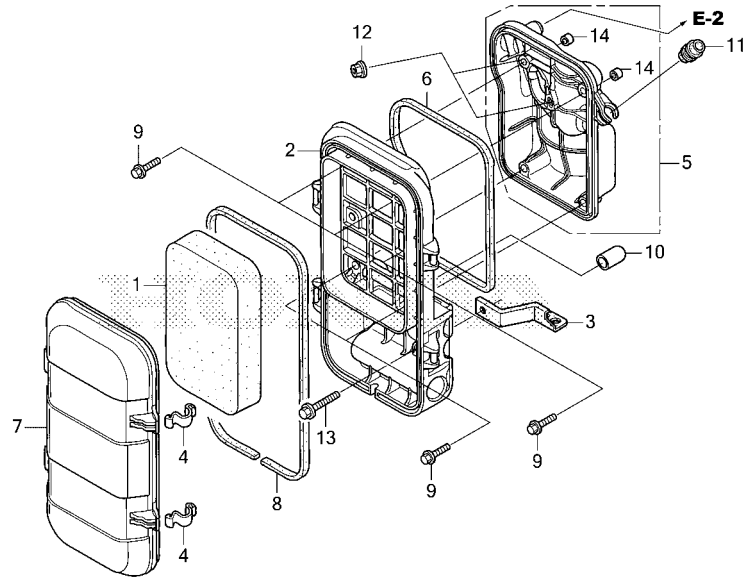

Z8T0E1504B

Ref. No. L.O.N. (Relative ref. Number) Description F.R.T.

Ref. No.	Part No.	Description	Reqd. QTY					Serial No.	Parts catalogue code
			GX 340 UT1	GX 340 UT2	GX 340 RT1	GX 340 RT2	GX 340 UT2X		
1	17211-899-000	ELEMENT, AIR CLEANER.....	-	-	-	1	-	VWC, VWC/A, VWE, VWE/A, VWS1, VWS1/A	
2	17220-Z23-S30	CASE COMP., AIR CLEANER.....	-	-	-	1	-	VWC, VWC/A, VWE, VWE/A, VWS1, VWS1/A	
3	17222-Z23-H60	STAY, AIR CLEANER.....	-	-	-	1	-	VWC, VWC/A, VWE, VWE/A, VWS1, VWS1/A	
4	17223-Z23-000	SPRING, AIR CLEANER CASE LID.....	-	-	-	2	-	VWC, VWC/A, VWE, VWE/A, VWS1, VWS1/A	
5	17223-ZBH-000	BASE COMP., AIR CLEANER.....	-	-	-	1	-	VWC/A, VWE/A, VWS1, VWS1/A	
	17223-Z23-S30	-	-	-	1	1075630	VWC, VWE	
	17223-ZBH-000	-	-	-	1	1075631	VWC, VWE	
6	17229-Z23-H60	SEAL, AIR CLEANER CASE.....	-	-	-	1	-	VWC, VWC/A, VWE, VWE/A, VWS1, VWS1/A	
7	17231-ZBH-000	COVER, AIR CLEANER.....	-	-	-	1	-	VWC/A, VWE/A, VWS1, VWS1/A	
	17231-Z23-H60	-	-	-	1	1013457	VWC, VWE	
	17231-ZBH-000	-	-	-	1	1013458	VWC, VWE	
8	17233-Z23-H60	SEAL, AIR CLEANER COVER.....	-	-	-	1	-	VWC, VWC/A, VWE, VWE/A, VWS1, VWS1/A	
9	90005-ZM3-000	BOLT, FLANGE, 5X18.....	-	-	-	4	-	VWC, VWC/A, VWE, VWE/A, VWS1, VWS1/A	
10	90802-Z6L-000	CAP, SEALING.....	-	-	-	1	-	VWC, VWC/A, VWE, VWE/A, VWS1, VWS1/A	
11	90854-ZB3-000	RUBBER, FUEL(9X15X20).....	-	-	-	1	-	VWC, VWC/A, VWE, VWE/A, VWS1, VWS1/A	
12	94050-06000	NUT, FLANGE, 6MM.....	-	-	-	2	-	VWC, VWC/A, VWE, VWE/A, VWS1, VWS1/A	
13	95701-06032-08	BOLT, FLANGE, 6X32.....	-	-	-	1	-	VWC, VWC/A, VWE, VWE/A, VWS1, VWS1/A	
14	17238-ZG9-M00	COLLAR, AIR CLEANER.....	-	-	-	2	-	VWC, VWC/A, VWE, VWE/A, VWS1, VWS1/A	

2

FR.

E-16

MUFFLER(1)

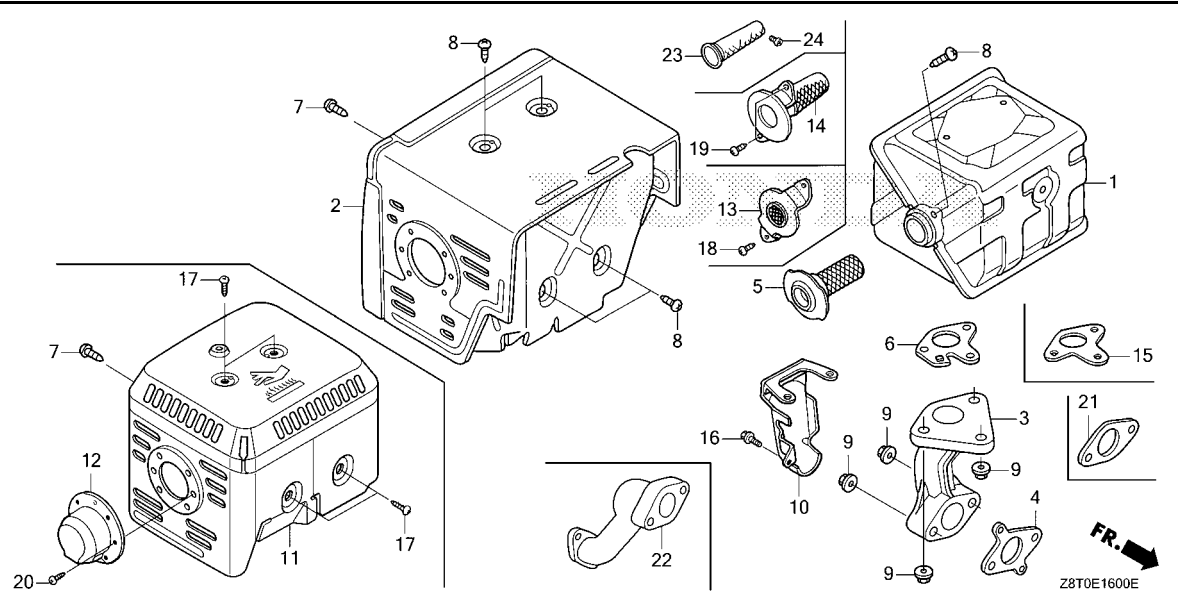

Ref. L.O.N. (Relative ref. Number) F.R.T.
 No. Description

Ref. No.	Part No.	Description	Reqd. QTY					Serial No.	Parts catalogue code
			GX 340 UT1	GX 340 UT2	GX 340 RT1	GX 340 RT2	GX 340 UT2X		
1	18310-ZE2-W61 18310-ZK6-880 18310-Z5T-010	MUFFLER COMP.(100DB) MUFFLER COMP.	1 1 -	- - 1	- - -	- - 1	- - 1	----- ----- -----	QXB7, VXB7, VXE7 QXB9, VXB9, VXE9 HA2, HA2/A, HX26, HX26/A, LX2, LXE4, LXQ4, LXQ4/A, LXU, QA2, QA2/A, QAE2, QAE2/A, QAE6, QAE6/A, QAG, QAH2, QAH2/A, QAP2, QAP2/A, QDW9, QE, QE/A, QHB4, QHB4/A, QHQ4, QKA4, QKA4/A, QNB2, QNE2, QNE2/A, QNR2, QNR2/A, QWC, QWC/A, QXB7, QXB7/A, QXB9, QXC9, QXE4, QXE4/A, QXE6, QXE8, QXQ4, QXQ4/A, QXU, QXU/A, QZA2, QZAV, QZN2, QZX4, SE, SE/A, SE1, SE2, SHQ4, SHQ4/A, SME0, SME0/A, SMX2, SXE4, SXE4/A, SXE8, SXQ4, SXQ4/A, VA2, VDE2, VWE2, VX16, VX16/A, VX8, VX8/A, VXB7, VXB9, VXE2, VXE2/A, VXE8, VXE8/A, VXE9
2	18320-ZF6-W01	PROTECTOR COMP., MUFFLER (100DB)	1	-	-	-	-	----- 1009787	QXB7, QXB9, VXB7, VXB9, VXE7, VXE9
3	18330-ZE2-W00 18331-Z5T-000	PIPE, EX.	1 -	- 1	- -	- 1	- 1	----- -----	QXB7, QXB9, VXB7, VXB9, VXE7, VXE9 HA2, HA2/A, HX26, HX26/A, LX2, LXE4, LXQ4, LXQ4/A, LXU, QA2, QA2/A, QAE2, QAE2/A, QAE6, QAE6/A, QAG, QAH2, QAH2/A, QAP2, QAP2/A, QDW9, QE, QE/A, QHB4, QHB4/A, QHQ4, QKA4, QKA4/A, QNB2, QNE2, QNE2/A, QNR2, QNR2/A, QWC, QWC/A, QXB7, QXB7/A, QXB9, QXC9, QXE4, QXE4/A, QXE6, QXE8, QXQ4, QXQ4/A, QXU, QXU/A, QZA2, QZAV, QZN2, QZX4, SE, SE/A, SE1, SE2, SHQ4, SHQ4/A, SME0, SME0/A, SMX2, SXE4, SXE4/A, SXE8, SXQ4, SXQ4/A, VA2, VDE2, VX16, VX16/A, VX8, VX8/A, VXB7, VXB9, VXE2, VXE2/A, VXE8, VXE8/A, VXE9
4	18333-ZF6-W01 18333-Z1C-901	GASKET, EX. PIPE	1 -	- 1	- -	- 1	- -	----- -----	1104461 VWE2 QXB7, QXB9, VXB7, VXB9, VXE7, VXE9 EDE2/A, EDN2/A, EDS6/A, EDT6/A, HA2/A, HX26/A, LXQ4/A, QA2/A, QAE2/A, QAE6/A, QAH2/A, QAP2/A, QE/A, QHB4/A, QKA4/A, QNE2/A, QNR2/A, QWC/A, QXB7/A, QXE4/A, QXQ4/A, QXU/A, SE/A, SE1, SE2, SHQ4/A, SME0/A, SXE4/A, SXQ4/A, VX16/A, VX8/A, VXE2/A, VXE8/A



E-16

MUFFLER(1)

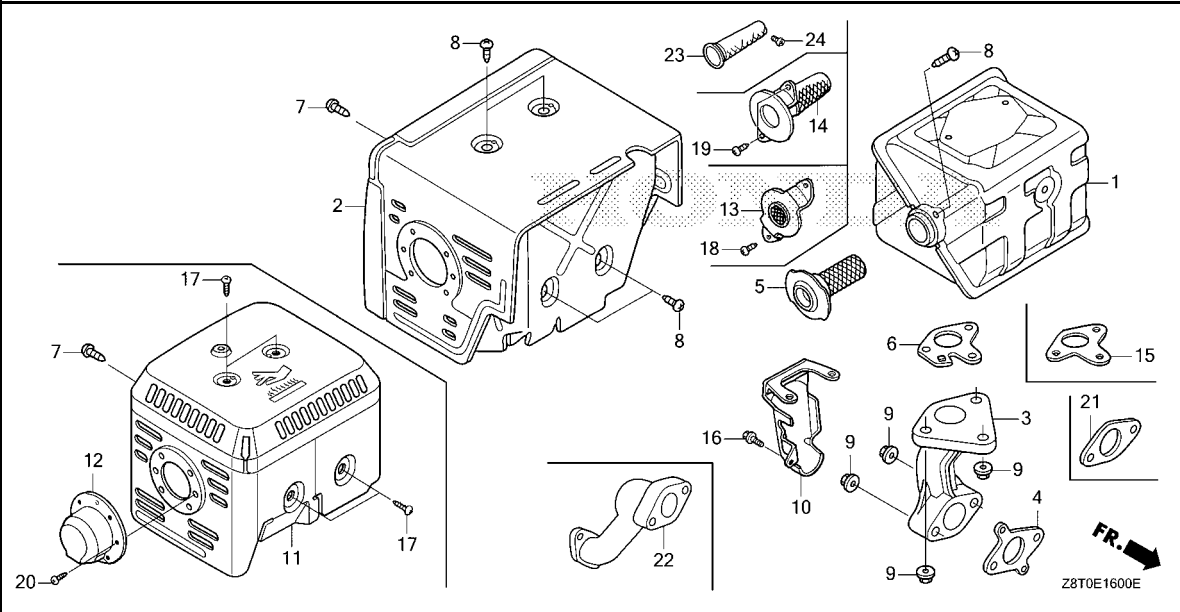

Ref. No.	Part No.	Description	Reqd. QTY					Serial No.	Parts catalogue code
			GX 340 UT1	GX 340 UT2	GX 340 RT1	GX 340 RT2	GX 340 UT2X		
(4)	18333-ZF6-W01	GASKET, EX. PIPE.....	-	1	-	-	-	1074364	HA2, HX26, LX2, LXE4, LXQ4, LXU, QA2, QAE2, QAE6, QAG, QAH2, QAP2, QDW9, QE, QHB4, QHQ4, QKA4, QNE2, QNR2, QWC, QXB7, QXB9, QXC9, QXE4, QXE6, QXE8, QXQ4, QXU, QZA2, QZAV, QZN2, QZX4, SE, SHQ4, SME0, SMX2, SXE4, SXE8, SXQ4, VA2, VX16, VX8, VXB7, VXB9, VXE2, VXE8, VXE9
	18333-Z1C-901	-	1	-	-	-	1074365	HA2, HX26, LX2, LXE4, LXQ4, LXU, QA2, QAE2, QAE6, QAG, QAH2, QAP2, QDW9, QE, QHB4, QHQ4, QKA4, QNE2, QNR2, QWC, QXB7, QXB9, QXC9, QXE4, QXE6, QXE8, QXQ4, QXU, QZA2, QZAV, QZN2, QZX4, SE, SHQ4, SME0, SMX2, SXE4, SXE8, SXQ4, VA2, VX16, VX8, VXB7, VXB9, VXE2, VXE8, VXE9
	18333-ZF6-W01	-	-	-	1	-	1076216	EDE2, EDN2, EDS6, EDT6, QNB2, VDE2, VWE2
	18333-Z1C-901	-	-	-	1	-	1076217	EDE2, EDN2, EDS6, EDT6, QNB2, VDE2
			-	-	-	1	-	1104461	VWE2
			-	-	-	1	-		HA2, HX26, LXQ4, QA2, QAE2, QAE6, QAH2, QAP2, QE, QHB4, QKA4, QNE2, QNR2, QWC, QXB7, QXE4, QXQ4, SE, SE1, SE2, SME0, SXE4, SXQ4, VX8, VXE8
5	18355-ZE2-W00	ARRESTER, SPARK.....	1	-	-	-	-		QXB7, QXB9, VXB7, VXB9, VXE7, VXE9
6	18381-Z8S-801	GASKET, MUFFLER(ARRESTER) (THAI LEAKLESS)	1	-	-	1	-		QNB2, QXB7, QXB9, VDE2, VXB7, VXB9, VXE7, VXE9
	18381-ZE2-W10	GASKET, MUFFLER(ARRESTER) (NIPPON LEAKLESS)	1	-	-	1	-		QNB2, QXB7, QXB9, VDE2, VXB7, VXB9, VXE7, VXE9
	18381-Z8S-801	GASKET, MUFFLER(ARRESTER) (THAI LEAKLESS)	-	1	-	-	1		HA2, HA2/A, QA2, QA2/A, QAE2, QAE2/A, QAE6, QAE6/A, QAG, QAH2, QAH2/A, QAP2, QAP2/A, QDW9, QE, QE/A, QHB4, QHB4/A, QKA4, QKA4/A, QWC, QWC/A, QXB7, QXB7/A, QXB9, QZA2, QZAV, SE, SE/A, SE1, SE2, SMX2, VA2, VXB7, VXB9, VXE9



E-16

MUFFLER(1)

Ref. No.	Part No.	Description	Reqd. QTY					Serial No.	Parts catalogue code
			GX 340 UT1	GX 340 UT2	GX 340 RT1	GX 340 RT2	GX 340 UT2X		
(6)	18381-ZE2-W10	GASKET, MUFFLER (ARRESTER) (NIPPON LEAKLESS)	-	1	-	-	1	-----	HA2, HA2/A, QA2, QA2/A, QAE2, QAE2/A, QAE6, QAE6/A, QAG, QAH2, QAH2/A, QAP2, QAP2/A, QDW9, QE, QE/A, QHB4, QHB4/A, QKA4, QKA4/A, QWC, QWC/A, QXB7, QXB7/A, QXB9, QZA2, QZAV, SE, SE/A, SE1, SE2, SMX2, VA2, VXB7, VXB9, VXE9
	18381-Z8S-801	GASKET, MUFFLER (ARRESTER) (THAI LEAKLESS)	-	-	-	-	1	-----	1104461 VWE2
	18381-ZE2-W10	GASKET, MUFFLER (ARRESTER) (NIPPON LEAKLESS)	-	-	-	-	1	-----	1104461 VWE2
7	90006-ZE2-000	SCREW, TAPPING, 6X10.....	1	-	-	-	1	-----	QNB2, QXB7, QXB9, VDE2, VXB7, VXB9, VXE7, VXE9
			-	1	-	-	1	-----	HA2, HA2/A, HX26, HX26/A, LX2, LXE4, LXQ4, LXQ4/A, LXU, QA2, QA2/A, QAE2, QAE2/A, QAE6, QAE6/A, QAG, QAH2, QAH2/A, QAP2, QAP2/A, QDW9, QE, QE/A, QHB4, QHB4/A, QHQ4, QKA4, QKA4/A, QNE2, QNE2/A, QNR2, QNR2/A, QWC, QWC/A, QXB7, QXB7/A, QXB9, QXC9, QXE4, QXE4/A, QXE6, QXE8, QXQ4, QXQ4/A, QXU, QXU/A, QZA2, QZAV, QZN2, QZX4, SE, SE/A, SE1, SE2, SHQ4, SHQ4/A, SME0, SME0/A, SMX2, SXE4, SXE4/A, SXE8, SXQ4, SXQ4/A, VA2, VX16, VX16/A, VX8, VX8/A, VXB7, VXB9, VXE2, VXE2/A, VXE8, VXE8/A, VXE9
8	90050-ZE1-000	SCREW, TAPPING, 5X8.....	-	-	-	-	1	-----	1104461 VWE2
9	94050-08000	NUT, FLANGE, 8MM.....	5	-	-	-	-	-----	QXB7, QXB9, VXB7, VXB9, VXE7, VXE9
			5	-	-	-	2	-----	EDE2, EDE2/A, EDN2, EDN2/A, EDS6, EDS6/A, EDT6, EDT6/A, QXB7, QXB9, VXB7, VXB9, VXE7, VXE9
			-	5	-	-	5	-----	HA2, HA2/A, HX26, HX26/A, LX2, LXE4, LXQ4, LXQ4/A, LXU, QA2, QA2/A, QAE2, QAE2/A, QAE6, QAE6/A, QAG, QAH2, QAH2/A, QAP2, QAP2/A, QDW9, QE, QE/A, QHB4, QHB4/A, QHQ4, QKA4, QKA4/A, QNE2, QNE2/A, QNR2, QNR2/A, QWC, QWC/A, QXB7, QXB7/A, QXB9, QXC9, QXE4, QXE4/A, QXE6, QXE8, QXQ4, QXQ4/A, QXU, QXU/A, QZA2, QZAV, QZN2, QZX4, SE, SE/A, SE1, SE2, SHQ4, SHQ4/A, SME0, SME0/A, SMX2, SXE4, SXE4/A, SXE8, SXQ4, SXQ4/A, VA2, VX16, VX16/A, VX8, VX8/A, VXB7, VXB9, VXE2, VXE2/A, VXE8, VXE8/A, VXE9
			-	-	-	-	5	-----	QNB2, VDE2
			-	-	-	-	5	-----	1104461 VWE2
10	18323-Z5T-W41	PROTECTOR, EX. PIPE.....	-	1	-	-	1	-----	HA2, HA2/A, QA2, QA2/A, QAE2, QAE2/A, QAE6, QAE6/A, QAG, QAH2, QAH2/A, QAP2, QAP2/A, QNB2, QNE2, QNE2/A, QNR2, QNR2/A, QWC, QWC/A, QZA2, QZAV, QZN2, VA2, VDE2
11	18320-Z5T-000	PROTECTOR COMP., MUFFLER.....	-	1	-	-	1	-----	HA2, HA2/A, HX26, HX26/A, LX2, LXE4, LXQ4, LXQ4/A, LXU, QA2, QA2/A, QAE2, QAE2/A, QAE6, QAE6/A, QAG, QAH2, QAH2/A, QAP2, QAP2/A, QDW9, QE, QE/A, QHB4, QHB4/A, QHQ4, QKA4, QKA4/A, QNB2, QNE2, QNE2/A, QNR2, QNR2/A, QWC, QWC/A, QXC9, QXE4, QXE4/A, QXE6, QXE8, QXQ4, QXQ4/A, QXU, QXU/A, QZA2, QZAV, QZN2, QZX4, SE, SE/A, SE1, SE2, SHQ4, SHQ4/A, SME0, SME0/A, SMX2, SXE4, SXE4/A, SXE8, SXQ4, SXQ4/A, VA2, VDE2, VX16, VX16/A, VX8, VX8/A, VXE2, VXE2/A, VXE8, VXE8/A
	18320-Z5T-800	PROTECTOR COMP., MUFFLER (100DB)	-	1	-	-	1	-----	QXB7, QXB7/A, QXB9, VXB7, VXB9, VXE9
	18320-Z5T-000	PROTECTOR COMP., MUFFLER.....	-	-	-	-	1	-----	1104461 VWE2
12	18331-ZE3-811	CAP, MUFFLER.....	-	1	-	-	1	-----	HA2, HA2/A, QA2, QA2/A, QAE2, QAE2/A, QAE6, QAE6/A, QAH2, QAH2/A, QAP2, QAP2/A, QE, QE/A, QHB4, QHB4/A, QKA4, QKA4/A, QNB2, QNE2, QNE2/A, QNR2, QNR2/A, QWC, QWC/A, QZA2, QZAV, QZN2, SE, SE/A, SE1, SE2, VA2
13	18336-ZE3-000	FLANGE COMP., BAFFLE.....	-	1	-	-	1	-----	HX26, HX26/A, LX2, LXE4, LXQ4, LXQ4/A, LXU, QHQ4, QNE2, QNE2/A, QNR2, QNR2/A, QXC9, QXE4, QXE4/A, QXE6, QXE8, QXQ4, QXQ4/A, QXU, QXU/A, QZN2, QZX4, SHQ4, SHQ4/A, SME0, SME0/A, SXE4, SXE4/A, SXE8, SXQ4, SXQ4/A, VX16, VX16/A, VX8, VX8/A, VXE2, VXE2/A, VXE8, VXE8/A



E-16

MUFFLER(1)

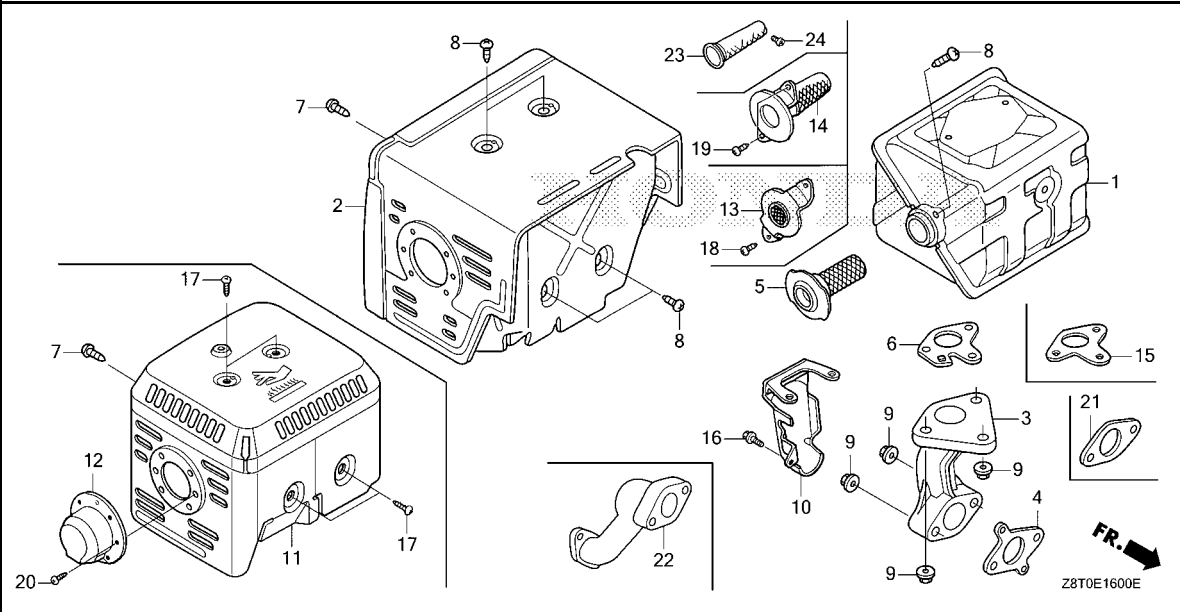

Ref. No.	Part No.	Description	Reqd. QTY					Serial No.	Parts catalogue code
			GX 340 UT1	GX 340 UT2	GX 340 RT1	GX 340 RT2	GX 340 UT2X		
14	18350-Z5T-800	ARRESTER COMP., SPARK	-	1	-	1	1	HA2, HA2/A, QA2, QA2/A, QAE2, QAE2/A, QAE6, QAE6/A, QAG, QAH2, QAH2/A, QAP2, QAP2/A, QDW9, QE, QE/A, QHB4, QHB4/A, QKA4, QKA4/A, QNB2, QWC, QWC/A, QXB7, QXB7/A, QXB9, QZA2, QZAV, SE, SE/A, SE1, SE2, SMX2, VA2, VDE2, VXB7, VXB9, VXE9	
			-	(1)	-	-	(1)	HX26, HX26/A, LX2, LXE4, LXQ4, LXQ4/A, LXU, QHQ4, QNE2, QNE2/A, QNR2, QNR2/A, QXC9, QXE4, QXE4/A, QXE6, QXE8, QXQ4, QXQ4/A, QXU, QXU/A, QZN2, QZX4, SHQ4, SHQ4/A, SME0, SME0/A, SMX2, SXE4, SXE4/A, SXE8, SXQ4, SXQ4/A, VX16, VX16/A, VX8, VX8/A, VXE2, VXE2/A, VXE8, VXE8/A	
15	18381-Z1C-801	GASKET, MUFFLER(THAI LEAKLESS)	-	1	-	-	1	1104461 VWE2	
	18381-ZE2-801	GASKET, MUFFLER (NIPPON LEAKLESS)	-	1	-	-	1	HX26, HX26/A, LX2, LXE4, LXQ4, LXQ4/A, LXU, QHQ4, QNE2, QNE2/A, QNR2, QNR2/A, QXC9, QXE4, QXE4/A, QXE6, QXE8, QXQ4, QXQ4/A, QXU, QXU/A, QZN2, QZX4, SHQ4, SHQ4/A, SME0, SME0/A, SXE4, SXE4/A, SXE8, SXQ4, SXQ4/A, VX16, VX16/A, VX8, VX8/A, VXE2, VXE2/A, VXE8, VXE8/A	
16	90013-883-000	BOLT, FLANGE, 6X12(CT200)	-	1	-	1	1	HA2, HA2/A, QA2, QA2/A, QAE2, QAE2/A, QAE6, QAE6/A, QAG, QAH2, QAH2/A, QAP2, QAP2/A, QNB2, QNE2, QNE2/A, QNR2, QNR2/A, QWC, QWC/A, QZA2, QZAV, QZN2, VA2, VDE2	



E-16

MUFFLER(1)

Ref. No.	Part No.	Description	Reqd. QTY					Serial No.	Parts catalogue code
			GX 340 UT1	GX 340 UT2	GX 340 RT1	GX 340 RT2	GX 340 UT2X		
17	90050-ZE1-000	SCREW, TAPPING, 5X8.....	-	4	-	4	4	-----	HA2, HA2/A, HX26, HX26/A, LX2, LXE4, LXQ4, LXQ4/A, LXU, QA2, QA2/A, QAE2, QAE2/A, QAE6, QAE6/A, QAG, QAH2, QAH2/A, QAP2, QAP2/A, QDW9, QE, QE/A, QHB4, QHB4/A, QHQ4, QKA4, QKA4/A, QNB2, QNE2, QNE2/A, QNR2, QNR2/A, QWC, QWC/A, QXB7, QXB7/A, QXB9, QXC9, QXE4, QXE4/A, QXE6, QXE8, QXQ4, QXQ4/A, QXU, QXU/A, QZA2, QZAV, QZN2, QZX4, SE, SE/A, SE1, SE2, SHQ4, SHQ4/A, SME0, SME0/A, SMX2, SXE4, SXE4/A, SXE8, SXQ4, SXQ4/A, VA2, VDE2, VX16, VX16/A, VX8, VX8/A, VXB7, VXB9, VXE2, VXE2/A, VXE8, VXE8/A, VXE9
18	90050-ZE1-000	SCREW, TAPPING, 5X8.....	-	2	-	-	4	-----	1104461 VWE2
19	90050-ZE1-000	SCREW, TAPPING, 5X8.....	-	2	-	2	2	-----	HX26, HX26/A, LX2, LXE4, LXQ4, LXQ4/A, LXU, QHQ4, QNE2, QNE2/A, QNR2, QNR2/A, QXC9, QXE4, QXE4/A, QXE6, QXE8, QXQ4, QXQ4/A, QXU, QXU/A, QZN2, QZX4, SHQ4, SHQ4/A, SME0, SME0/A, SXE4, SXE4/A, SXE8, SXQ4, SXQ4/A, VX16, VX16/A, VX8, VX8/A, VXE2, VXE2/A, VXE8, VXE8/A
			-	(2)	-	-	(2)	-----	HA2, HA2/A, QA2, QA2/A, QAE2, QAE2/A, QAE6, QAE6/A, QAG, QAH2, QAH2/A, QAP2, QAP2/A, QDW9, QE, QE/A, QHB4, QHB4/A, QKA4, QKA4/A, QNB2, QWC, QWC/A, QXB7, QXB7/A, QXB9, QZA2, QZAV, SE, SE/A, SE1, SE2, SMX2, VA2, VDE2, VXB7, VXB9, VXE9
			-	-	-	2	-	-----	1104461 VWE2
20	90055-ZE1-000	SCREW, TAPPING, 4X6.....	-	3	-	3	3	-----	HX26, HX26/A, LX2, LXE4, LXQ4, LXQ4/A, LXU, QHQ4, QNE2, QNE2/A, QNR2, QNR2/A, QXC9, QXE4, QXE4/A, QXE6, QXE8, QXQ4, QXQ4/A, QXU, QXU/A, QZN2, QZX4, SHQ4, SHQ4/A, SME0, SME0/A, SMX2, SXE4, SXE4/A, SXE8, SXQ4, SXQ4/A, VX16, VX16/A, VX8, VX8/A, VXE2, VXE2/A, VXE8, VXE8/A
21	18333-ZK6-Y00	GASKET, EX. PIPE.....	-	1	-	-	1	-----	QAH2, QAH2/A
22	18330-ZE3-700	PIPE, EX.....	-	-	-	1	-	-----	EDE2, EDE2/A, EDN2, EDN2/A, EDS6, EDS6/A, EDT6, EDT6/A
23	18355-ZB4-630	ARRESTER, SPARK.....	-	-	-	(1)	-	-----	EDE2, EDE2/A, EDN2, EDN2/A
24	90055-ZE1-000	SCREW, TAPPING, 4X6.....	-	-	-	(1)	-	-----	EDE2, EDE2/A, EDN2, EDN2/A



E-16-1

MUFFLER(2)

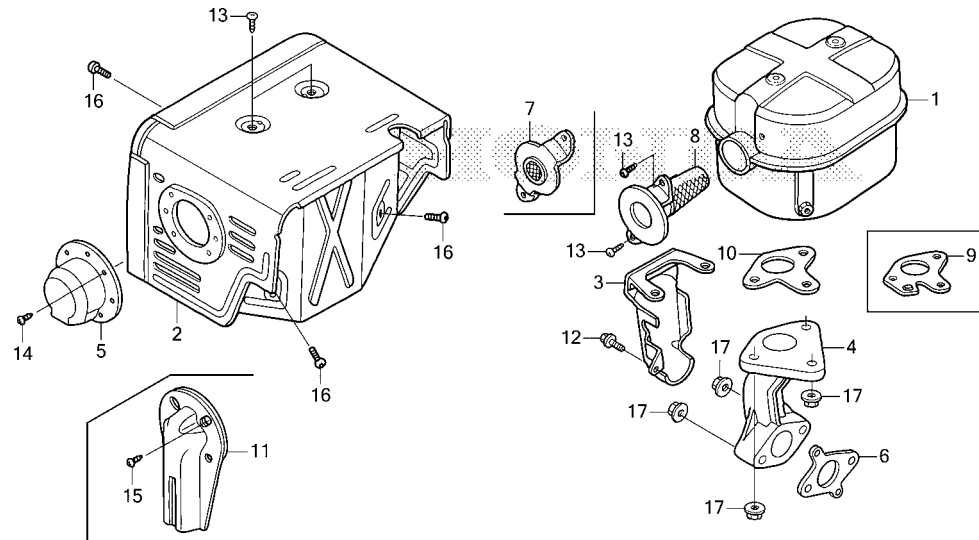

Ref. L.O.N. (Relative ref. Number) F.R.T.
No. Description

Ref. No.	Part No.	Description	Reqd. QTY					Serial No.	Parts catalogue code
			GX 340 UT1	GX 340 UT2	GX 340 RT1	GX 340 RT2	GX 340 UT2X		
1	18310-Z8T-000	MUFFLER COMP.	1	-	-	-	-	1027341	QNE2, QNR2, QNR6
			1	-	-	-	-	1031340	QDW9, QE, QHB4, QKA4, SE
			1	-	-	-	-	1031700	HA2, QA2, QA26, QAE2, QAE6, QAG, QAH2, QAP2, VA2
			1	-	-	-	-	1032557	HX26, LX2, LXE4, LXE8, LXQ4, LXU, QHQ4, QXC4, QXC6, QXC9, QXE4, QXE6, QXE8, QXQ4, QXU, SHQ4, SME0, SXE4, SXE8, SXQ4, VX16, VX8, VXE2, VXE8
			1	-	-	-	-	1027342	QNE2, QNR2, QNR6
18310-Z8T-800	1	-	-	-	-	1031341	QDW9, QE, QHB4, QKA4, SE
			1	-	-	-	-	1031701	HA2, QA2, QA26, QAE2, QAE6, QAG, QAH2, QAP2, VA2
			1	-	-	-	-	1032558	HX26, LX2, LXE4, LXE8, LXQ4, LXU, QHQ4, QXC4, QXC6, QXC9, QXE4, QXE6, QXE8, QXQ4, QXU, SHQ4, SME0, SXE4, SXE8, SXQ4, VX16, VX8, VXE2, VXE8
			1	-	-	-	-	1016322	QNB2, VAD2, VDE2, VW12
18310-ZE3-W00	-	-	1	-	-	1016321	VWE2
18310-Z8T-000	-	-	1	-	-	1016322	VWE2
18310-Z8T-800	-	-	1	-	-	1016322	VWE2
2	18320-ZE3-W01	PROTECTOR COMP., MUFFLER.....	1	-	1	-	-	1007578	HA2, HX26, LX2, LXE4, LXE8, LXQ4, LXU, QA2, QA26, QAE2, QAE6, QAG, QAH2, QAP2, QDW9, QE, QHB4, QHQ4, QKA4, QNB2, QNE2, QNR2, QNR6, QXC4, QXC6, QXC9, QXE4, QXE6, QXE8, QXQ4, QXU, SE, SHQ4, SME0, SXE4, SXE8, SXQ4, VA2, VAD2, VDE2, VW12, VWE2, VX16, VX8, VXE2, VXE8
			1	-	1	-	-	1007579	HA2, HX26, LX2, LXE4, LXE8, LXQ4, LXU, QA2, QA26, QAE2, QAE6, QAG, QAH2, QAP2, QDW9, QE, QHB4, QHQ4, QKA4, QNB2, QNE2, QNR2, QNR6, QXC4, QXC6, QXC9, QXE4, QXE6, QXE8, QXQ4, QXU, SE, SHQ4, SME0, SXE4, SXE8, SXQ4, VA2, VAD2, VDE2, VW12, VWE2, VX16, VX8, VXE2, VXE8
3	18323-ZE3-W40	PROTECTOR, EX. PIPE.....	1	-	1	-	-	-----	HA2, QA2, QA26, QAE2, QAE6, QAG, QAH2, QAP2, QNB2, QNE2, QNR2, QNR6, VA2, VAD2, VDE2, VW12
4	18330-ZE2-W00	PIPE, EX.	1	-	1	-	-	-----	HA2, HX26, LX2, LXE4, LXE8, LXQ4, LXU, QA2, QA26, QAE2, QAE6, QAG, QAH2, QAP2, QDW9, QE, QHB4, QHQ4, QKA4, QNB2, QNE2, QNR2, QNR6, QXC4, QXC6, QXC9, QXE4, QXE6, QXE8, QXQ4, QXU, SE, SHQ4, SME0, SXE4, SXE8, SXQ4, VA2, VAD2, VDE2, VW12, VWE2, VX16, VX8, VXE2, VXE8
5	18331-ZE3-811	CAP, MUFFLER.....	1	-	1	-	-	-----	HA2, QA2, QA26, QAE2, QAE6, QAH2, QAP2, QE, QHB4, QKA4, QNB2, QNE2, QNR2, QNR6, SE, VA2

FR. →
Z8T0E1601A

E-16-1

MUFFLER(2)

Ref. No.	Part No.	Description	Reqd. QTY					Serial No.	Parts catalogue code
			GX 340 UT1	GX 340 UT2	GX 340 RT1	GX 340 RT2	GX 340 UT2X		
6	18333-ZF6-W01	GASKET, EX. PIPE.....	1	-	1	-	-	HA2, HX26, LX2, LXE4, LXE8, LXQ4, LXU, QA2, QA26, QAE2, QAE6, QAG QAH2, QAP2, QDW9, QE, QHB4, QHQ4, QKA4, QNB2, QNE2, QNR2, QNR6, QXC4 QXC6, QXC9, QXE4, QXE6, QXE8, QXQ4, QXU, SE, SHQ4, SME0, SXE4, SXE8 SXQ4, VA2, VAD2, VC2, VDE2, VW12, VWC, VWE, VWE2, VX16, VX8, VXE2 VXE8	
7	18336-ZE3-000	FLANGE COMP., BAFFLE.....	1	-	-	-	-	HX26, LX2, LXE4, LXE8, LXQ4, LXU, QHQ4, QNE2, QNR2, QNR6, QXC4, QXC6 QXC9, QXE4, QXE6, QXE8, QXQ4, QXU, SHQ4, SME0, SXE4, SXE8, SXQ4 VX16, VX8, VXE2, VXE8	
8	18355-ZE3-010	ARRESTER, SPARK.....	1	-	1	-	-	HA2, QA2, QA26, QAE2, QAE6, QAG, QAH2, QAP2, QDW9, QE, QHB4, QKA4 QNB2, SE, VA2, VAD2, VDE2, VW12, VWE2	
			(1)	-	-	-	-	HX26, LX2, LXE4, LXE8, LXQ4, LXU, QHQ4, QNE2, QNR2, QNR6, QXC4, QXC6 QXC9, QXE4, QXE6, QXE8, QXQ4, QXU, SHQ4, SME0, SXE4, SXE8, SXQ4 VX16, VX8, VXE2, VXE8	
9	18381-ZE2-W10	GASKET, MUFFLER(ARRESTER) (NIPPON LEAKLESS)	(1)	-	(1)	-	-	HA2, HX26, LX2, LXE4, LXE8, LXQ4, LXU, QA2, QA26, QAE2, QAE6, QAG QAH2, QAP2, QDW9, QE, QHB4, QHQ4, QKA4, QNE2, QNR2, QNR6, QXC4, QXC6 QXC9, QXE4, QXE6, QXE8, QXQ4, QXU, SE, SHQ4, SME0, SXE4, SXE8, SXQ4 VA2, VC2, VWE2, VX16, VX8, VXE2, VXE8	
	18381-Z8S-801	GASKET, MUFFLER(ARRESTER) (THAI LEAKLESS)	1	-	1	-	-	HA2, QA2, QA26, QAE2, QAE6, QAG, QAH2, QAP2, QDW9, QE, QHB4, QKA4, SE VA2, VWE2	
	18381-ZE2-W10	GASKET, MUFFLER(ARRESTER) (NIPPON LEAKLESS)	-	-	1	-	-	QNB2, VAD2, VDE2, VW12	
10	18381-Z1C-801	GASKET, MUFFLER(THAI LEAKLESS)	1	-	-	-	-	HX26, LX2, LXE4, LXE8, LXQ4, LXU, QHQ4, QNE2, QNR2, QNR6, QXC4, QXC6 QXC9, QXE4, QXE6, QXE8, QXQ4, QXU, SHQ4, SME0, SXE4, SXE8, SXQ4 VX16, VX8, VXE2, VXE8	
11	18430-ZF6-W50	DEFLECTOR COMP., MUFFLER.....	(1)	-	-	-	-	QE, QHB4, QKA4, SE	
12	90013-883-000	BOLT, FLANGE, 6X12(CT200).....	1	-	1	-	-	HA2, QA2, QA26, QAE2, QAE6, QAG, QAH2, QAP2, QNB2, QNE2, QNR2, QNR6 VA2, VAD2, VDE2, VW12	
13	90050-ZE1-000	SCREW, TAPPING, 5X8.....	4	-	4	-	-	HA2, HX26, LX2, LXE4, LXE8, LXQ4, LXU, QA2, QA26, QAE2, QAE6, QAG QAH2, QAP2, QDW9, QE, QHB4, QHQ4, QKA4, QNB2, QNE2, QNR2, QNR6, QXC4 QXC6, QXC9, QXE4, QXE6, QXE8, QXQ4, QXU, SE, SHQ4, SME0, SXE4, SXE8 SXQ4, VA2, VAD2, VDE2, VW12, VWE2, VX16, VX8, VXE2, VXE8	
14	90055-ZE1-000	SCREW, TAPPING, 4X6.....	3	-	3	-	-	HA2, QA2, QA26, QAE2, QAE6, QAH2, QAP2, QE, QHB4, QKA4, QNB2, QNE2 QNR2, QNR6, SE, VA2	
15	90055-ZE1-000	SCREW, TAPPING, 4X6.....	(2)	-	-	-	-	QE, QHB4, QKA4, SE	
16	93500-06006-0B	SCREW, PAN, 6X6.....	3	-	3	-	-	HA2, HX26, LX2, LXE4, LXE8, LXQ4, LXU, QA2, QA26, QAE2, QAE6, QAG QAH2, QAP2, QDW9, QE, QHB4, QHQ4, QKA4, QNB2, QNE2, QNR2, QNR6, QXC4 QXC6, QXC9, QXE4, QXE6, QXE8, QXQ4, QXU, SE, SHQ4, SME0, SXE4, SXE8 SXQ4, VA2, VAD2, VDE2, VW12, VWE2, VX16, VX8, VXE2, VXE8	
17	94050-08000	NUT, FLANGE, 8MM.....	5	-	5	-	-	HA2, HX26, LX2, LXE4, LXE8, LXQ4, LXU, QA2, QA26, QAE2, QAE6, QAG QAH2, QAP2, QDW9, QE, QHB4, QHQ4, QKA4, QNB2, QNE2, QNR2, QNR6, QXC4 QXC6, QXC9, QXE4, QXE6, QXE8, QXQ4, QXU, SE, SHQ4, SME0, SXE4, SXE8 SXQ4, VA2, VAD2, VDE2, VW12, VWE2, VX16, VX8, VXE2, VXE8	



E-16-2

MUFFLER(3)

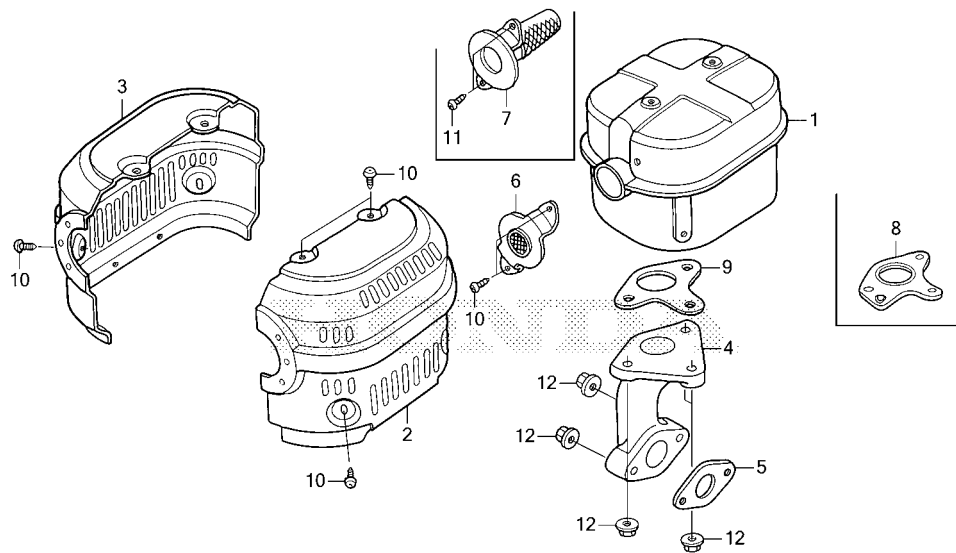

Ref. L.O.N. (Relative ref. Number) F.R.T.
 No. Description

Ref. No.	Part No.	Description	Reqd. QTY					Serial No.	Parts catalogue code
			GX 340 UT1	GX 340 UT2	GX 340 RT1	GX 340 RT2	GX 340 UT2X		
1	18310-ZE3-003	MUFFLER COMP.	(1)	-	-	-	-	----- QAP2	
	18310-Z8T-800	1	-	-	-	----- 1031700	PKT2	
	18310-Z8T-000	1	-	-	-	----- 1031701	PKT2	
	18310-Z8T-010	-	1	-	-	-----	PKT2, PKT2/A, PKX2, PKX2/A, QMT2, QMT2/A	
2	18320-ZE3-G10	PROTECTOR, R. MUFFLER (ALUMINIZED)	(1)	-	-	-	-----	1000633 QAP2	
			1	-	-	-	-----	1010089 PKT2	
	18320-ZE3-G11	(1)	-	-	-	----- 1000634	QAP2	
			1	-	-	-	----- 1010090	PKT2	
			-	1	-	-	-----	PKT2, PKT2/A, PKX2, PKX2/A, QMT2, QMT2/A	
3	18325-ZE3-G10	PROTECTOR, L. MUFFLER (ALUMINIZED)	1	1	-	-	-----	PKT2, PKT2/A, PKX2, PKX2/A, QMT2, QMT2/A	
			(1)	-	-	-	-----	QAP2	
4	18330-ZE2-000	PIPE, EX.	1	1	-	-	-----	PKT2, PKT2/A, PKX2, PKX2/A, QMT2, QMT2/A	
			(1)	-	-	-	-----	QAP2	
5	18333-Z1C-801	GASKET, EX. PIPE.....	1	1	-	-	-----	PKT2, PKT2/A, PKX2, PKX2/A, QMT2, QMT2/A	
6	18336-ZE3-000	FLANGE COMP., BAFFLE.....	1	1	-	-	-----	PKT2, PKT2/A, PKX2, PKX2/A, QMT2, QMT2/A	
7	18355-ZE3-010	ARRESTER, SPARK.....	(1)	-	-	-	-----	PKT2, QAP2	
			-	(1)	-	(1)	-----	PKT2, PKT2/A, PKX2, PKX2/A, QMT2, QMT2/A	
8	18381-ZE2-W10	GASKET, MUFFLER(ARRESTER) (NIPPON LEAKLESS)	(1)	-	-	-	-----	PKT2	
	18381-ZE3-830	GASKET, MUFFLER(ARRESTER)....	(1)	-	-	-	-----	QAP2	
9	18381-Z1C-801	GASKET, MUFFLER(THAI LEAKLESS)	1	1	-	-	-----	PKT2, PKT2/A, PKX2, PKX2/A, QMT2, QMT2/A	
10	90050-ZE1-000	SCREW, TAPPING, 5X8.....	8	8	-	-	-----	PKT2, PKT2/A, PKX2, PKX2/A, QMT2, QMT2/A	
			(6)	-	-	-	-----	QAP2	
11	90050-ZE1-000	SCREW, TAPPING, 5X8.....	(2)	-	-	-	-----	PKT2, QAP2	
			-	(2)	-	(2)	-----	PKT2, PKT2/A, PKX2, PKX2/A, QMT2, QMT2/A	

FR. →
Z8T0E1602A

E-16-2

MUFFLER(3)

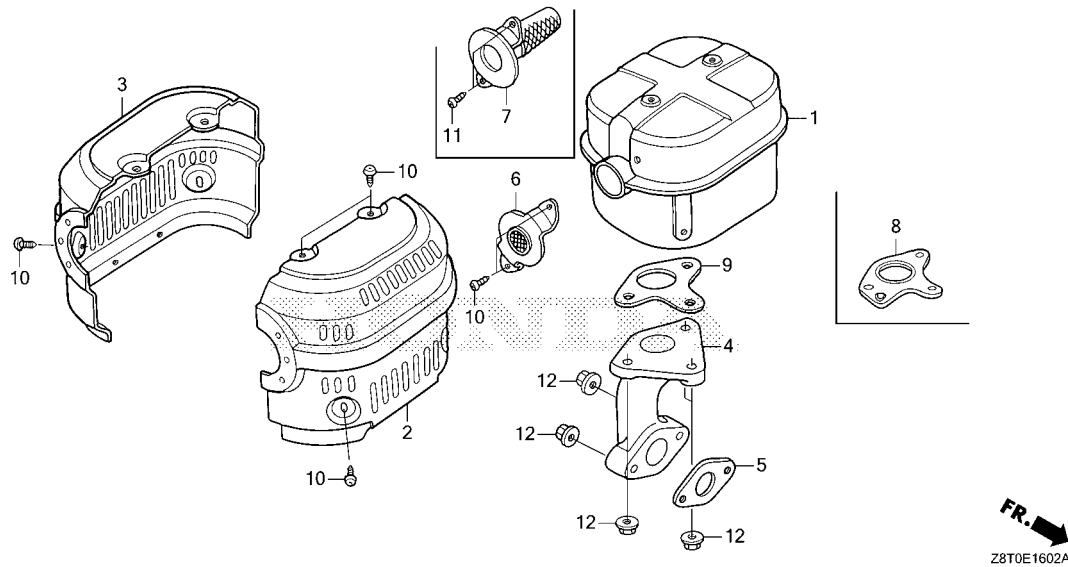

Ref. No.	Part No.	Description	Reqd. QTY					Serial No.	Parts catalogue code
			GX 340 UT1	GX 340 UT2	GX 340 RT1	GX 340 RT2	GX 340 UT2X		
12	94050-08000	NUT, FLANGE, 8MM.....	5	5	-	-	5	----- PKT2,PKT2/A,PKX2,PKX2/A,QMT2,QMT2/A	
			(5)	-	-	-	-	----- QAP2	



E-17

FUEL TANK

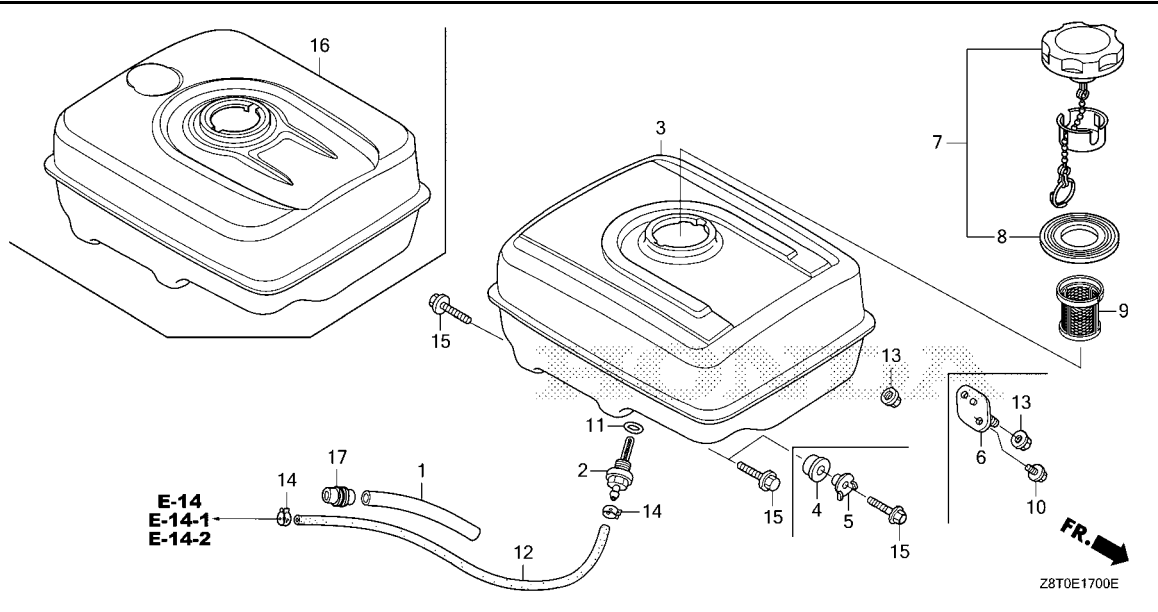

Ref. No.	L.O.N.	(Relative ref. Number) Description	F.R.T.
----------	--------	------------------------------------	--------

Ref. No.	Part No.	Description	Reqd. QTY					Serial No.	Parts catalogue code
			GX 340 UT1	GX 340 UT2	GX 340 RT1	GX 340 RT2	GX 340 UT2X		
1	16854-ZH8-000	RUBBER, SUPPORTER(107MM).....	1	1	1	1	1	-----	HA2, HA2/A, HX26, HX26/A, LX2, LXE4, LXE8, LXQ4, LXQ4/A, LXU, PKT2, PKT2/A, PKX2, PKX2/A, QA2, QA2/A, QA26, QAE2, QAE2/A, QAE6, QAE6/A, QAG, QAH2, QAH2/A, QAP2, QAP2/A, QDW9, QE, QE/A, QHB4, QHB4/A, QHQ4, QKA4, QKA4/A, QMT2, QMT2/A, QNB2, QNE2, QNE2/A, QNR2, QNR2/A, QNR6, QWC, QWC/A, QXB7, QXB7/A, QXB9, QXC4, QXC6, QXC9, QXE4, QXE4/A, QXE6, QXE8, QXQ4, QXQ4/A, QXU, QXU/A, QZA2, QZAV, QZN2, QZX4, SE, SE/A, SE1, SE2, SHQ4, SHQ4/A, SME0, SME0/A, SMX2, SXE4, SXE4/A, SXE8, SXQ4, SXQ4/A, VA2, VC2, VDE2, VW12, VWC, VWC/A, VWE, VWE/A, VWE2, VWE2/A, VX16, VX16/A, VX8, VX8/A, VXB7, VXB9, VXE2, VXE2/A, VXE7, VXE8, VXE8/A, VXE9
2	16955-ZE1-000	JOINT, FUEL TANK.....	1	-	-	-	-	-----	1018942
	16955-ZE1-010	1	-	-	-	-	-----	1018943
			-	1	-	-	1		
3	17510-Z5T-880ZC	TANK COMP., FUEL							
		NH31.....MCKINLEY WHITE	1	-	-	-	-	-----	VXB9, VXE9
	17510-Z5T-880ZD	*NH105*.....MAT BLACK(#15-#20)	1	-	-	-	-	-----	VXB9, VXE9
	17510-ZE3-801ZC	*NH31*.....MCKINLEY WHITE	1	-	-	-	-	-----	1000009
									HA2, HX26, LX2, LXE4, LXE8, LXQ4, LXU, PKT2, QA2, QA26, QAE2, QAE6, QAG, QAH2, QAP2, QE, QHB4, QHQ4, QKA4, QNE2, QNR2, QNR6, QXB7, QXB9, QXC4, QXC6, QXC9, QXE4, QXE6, QXE8, QXQ4, QXU, SE, SHQ4, SME0, SXE4, SXE8, SXQ4, VA2, VX16, VX8, VXB7, VXE2, VXE7, VXE8
	17510-ZE3-801ZA	*NH1*.....BLACK	1	-	-	-	-	-----	1000009
	17510-ZE3-801ZE	*T34*.....SIMPSON BLUE	1	-	-	-	-	-----	1000009
	17510-ZE3-801ZB	*NH105*.....MAT BLACK(#15-#20)	1	-	-	-	-	-----	1000009
	17510-ZE3-030ZA	*NH31*.....MCKINLEY WHITE	1	-	-	-	-	-----	1000010
									HA2, HX26, LX2, LXE4, LXE8, LXQ4, LXU, PKT2, QA2, QA26, QAE2, QAE6, QAG, QAH2, QAP2, QE, QHB4, QHQ4, QKA4, QNE2, QNR2, QNR6, QXB7, QXB9, QXC4, QXC6, QXC9, QXE4, QXE6, QXE8, QXQ4, QXU, SE, SHQ4, SME0, SXE4, SXE8, SXQ4, VA2, VX16, VX8, VXB7, VXE2, VXE7, VXE8
	17510-ZE3-030ZB	*NH1*.....BLACK	1	-	-	-	-	-----	1000010
	17510-ZE3-030ZD	*T34*.....SIMPSON BLUE	1	-	-	-	-	-----	1000010
									PKT2, QA2, QAE2, QAP2, QDW9, QKA4, QNR2, QXC9, QXQ4, QXU, SHQ4, SME0, QA2

2

E-17

FUEL TANK

Ref. No.	Part No.	Description	Reqd. QTY					Serial No.	Parts catalogue code
			GX 340 UT1	GX 340 UT2	GX 340 RT1	GX 340 RT2	GX 340 UT2X		
(3)	17510-ZE3-030ZE	TANK COMP., FUEL *NH105*...MAT BLACK(#15-#20)	1	-	-	-	-	1000010	----- VXB7, VXE2, VXE7
4	17532-ZK6-881	RUBBER A, TANK MOUNTING.....	2	2	-	-	-	-----	VXB9, VXE9
5	17534-ZK6-881	NUT, TANK MOUNTING.....	2	2	-	-	-	-----	VXB9, VXE9
6	17536-ZK6-880	RUBBER COMP., TANK MOUNTING..	2	2	-	-	-	-----	VXB9, VXE9
7	17620-Z4H-020	CAP COMP., FUEL FILLER.....	1	-	-	-	-	-----	
	17620-Z4H-900	-	1	-	-	-	-----	QXU/A, SHQ4/A, VXE2/A
	17620-Z4H-910	-	1	-	-	-	-----	SE2
	17620-Z4H-020	-	1	-	-	-	1033480	----- HA2, HX26, LX2, LXE4, LXQ4, LXU, PKT2, PKX2, QA2, QAE2, QAE6, QAG QAH2, QAP2, QDW9, QE, QHB4, QHQ4, QKA4, QMT2, QNE2, QNR2, QXB7, QXB9 QXC9, QXE4, QXE6, QXE8, QXQ4, QXU, QZA2, QZAV, QZN2, QZX4, SE, SHQ4 SME0, SMX2, SXE4, SXE8, SXQ4, VA2, VX16, VX8, VXB7, VXB9, VXE2, VXE8 VXE9
	17620-Z4H-900	-	1	-	-	-	2016863	----- HA2/A, HX26/A, LXQ4/A, PKT2/A, PKX2/A, QA2/A, QAE2/A, QAE6/A QAH2/A, QAP2/A, QE/A, QHB4/A, QKA4/A, QMT2/A, QNE2/A, QNR2/A QWC/A, QXB7/A, QXE4/A, QXQ4/A, SE/A, SE1, SME0/A, SXE4/A, SXQ4/A VX16/A, VX8/A, VXE8/A
	17620-Z4H-900	-	1	-	-	-	1074557	----- HA2, HX26, LX2, LXE4, LXQ4, LXU, PKT2, PKX2, QA2, QAE2, QAE6, QAG QAH2, QAP2, QDW9, QE, QHB4, QHQ4, QKA4, QMT2, QNE2, QNR2, QWC, QXB7 QXB9, QXE4, QXE6, QXE8, QXQ4, QXU, QZA2, QZAV, QZN2, QZX4, SE, SHQ4 SME0, SMX2, SXE4, SXE8, SXQ4, VA2, VX16, VX8, VXB7, VXB9, VXE2, VXE8 VXE9
	17620-Z4H-910	-	1	-	-	-	1074557	----- QXC9
	17620-Z4H-910	-	1	-	-	-	2016864	----- HA2/A, HX26/A, LXQ4/A, PKT2/A, PKX2/A, QA2/A, QAE2/A, QAE6/A QAH2/A, QAP2/A, QE/A, QHB4/A, QKA4/A, QMT2/A, QNE2/A, QNR2/A QWC/A, QXB7/A, QXC9, QXE4/A, QXQ4/A, SE/A, SE1, SME0/A, SXE4/A, SXQ4/A, VX16/A, VX8/A, VXE8/A
	17620-Z4H-920	-	-	-	-	-	1	
8	17631-Z0T-801	PACKING, FUEL FILLER CAP (39X62X3)(RADICON)	1	1	-	-	-	1	
	17631-Z1T-800	PACKING, FUEL FILLER CAP (39X62X3)(TOYOSHA)	-	1	-	-	-	-----	----- HA2, HA2/A, HX26, HX26/A, LXQ4, LXQ4/A, PKT2, PKT2/A, PKX2, PKX2/A QA2, QA2/A, QAE2, QAE2/A, QAE6, QAE6/A, QAH2, QAH2/A, QAP2, QAP2/A QE, QE/A, QHB4, QHB4/A, QKA4, QKA4/A, QMT2, QMT2/A, QNE2, QNE2/A QNR2, QNR2/A, QWC, QWC/A, QXB7, QXB7/A, QXC9, QXE4, QXE4/A, QXQ4 QXQ4/A, SE, SE/A, SE1, SE2, SME0, SME0/A, SXE4, SXE4/A, SXQ4 SXQ4/A, VX16, VX16/A, VX8, VX8/A, VXE8, VXE8/A
9	17672-Z4H-000	FILTER, FUEL.....	1	1	-	-	-	1	----- HA2, HA2/A, PKT2, PKT2/A, PKX2, PKX2/A, QA2, QA2/A, QA26, QAE2 QAE2/A, QAE6, QAE6/A, QAG, QAH2, QAH2/A, QAP2, QAP2/A, QE, QE/A QHB4, QHB4/A, QNE2, QNE2/A, QNR2, QNR2/A, QNR6, QWC, QWC/A, QZA2 QZAV, QZN2, SE, SE/A, SE1, SMX2, VA2
10	90008-ZE2-003	BOLT, FLANGE, 6X10.....	4	4	-	-	-	-----	----- VXB9, VXE9
11	91353-671-004	O-RING, 14MM(NOK).....	1	1	-	-	-	1	
12	91424-Z5L-802	TUBE, FUEL, 4.5X235(FKM).....	1	-	1	-	-	-----	----- HA2, HX26, LX2, LXE4, LXE8, LXQ4, LXU, PKT2, QA2, QA26, QAE2, QAE6 QAG, QAH2, QAP2, QDW9, QE, QHB4, QHQ4, QKA4, QNE2, QNR2, QNR6, QXB7 QXB9, QXC4, QXC6, QXC9, QXE4, QXE6, QXE8, QXQ4, QXU, SE, SHQ4, SME0 SXE4, SXE8, SXQ4, VA2, VC2, VDE2, VW12, VWC, VWE, VWE2, VX16, VX8 VXB7, VXB9, VXE2, VXE7, VXE8, VXE9
	91424-Z5T-003	-	1	-	-	-	-----	----- HA2, HA2/A, HX26, HX26/A, LX2, LXE4, LXQ4, LXQ4/A, LXU, PKT2 PKT2/A, PKX2, PKX2/A, QA2, QAE2, QAE2/A, QAE6, QAE6/A, QAG, QAH2 QAH2/A, QAP2, QAP2/A, QDW9, QE, QE/A, QHB4, QHB4/A, QHQ4, QKA4 QKA4/A, QMT2, QMT2/A, QNE2, QNR2, QNR2/A, QWC, QWC/A, QXB7, QXB7/A QXB9, QXE4, QXE4/A, QXE6, QXE8, QXQ4, QXQ4/A, QXU, QXU/A, QZA2 QZAV, QZN2, QZX4, SE, SE/A, SHQ4, SHQ4/A, SME0, SME0/A, SMX2, SXE4 SXE4/A, SXE8, SXQ4, SXQ4/A, VA2, VX16, VX8, VX8/A, VXB7, VXB9, VXE2 VXE2/A, VXE8, VXE8/A, VXE9



E-17

FUEL TANK

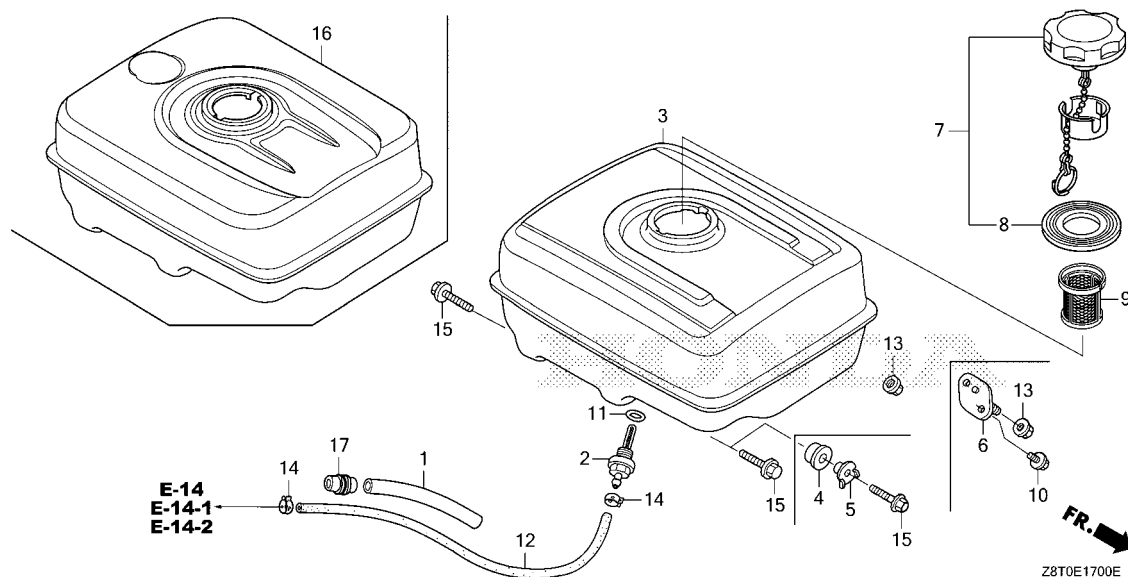

Ref. No.	Part No.	Description	Reqd. QTY					Serial No.	Parts catalogue code
			GX 340 UT1	GX 340 UT2	GX 340 RT1	GX 340 RT2	GX 340 UT2X		
12)	91424-Z5T-013	TUBE, FUEL, 4.5X235(FKM).....	-	1	-	-	-	HA2, HX26, LXQ4, PKT2, PKX2, QA2, QAE2, QAE6, QAH2, QAP2, QE, QHB4, QKA4, QMT2, QNE2, QNR2, QWC, QXB7, QXE4, QXQ4, SE, SE1, SE2, SME0, SXE4, SXQ4, VX16	
	91424-Z5T-003	-	1	-	-	2016863	HA2/A, HX26/A, LXQ4/A, PKT2/A, PKX2/A, QA2/A, QAE2/A, QAE6/A, QAH2/A, QAP2/A, QE/A, QHB4/A, QKA4/A, QMT2/A, QNE2/A, QNR2/A, QWC/A, QXB7/A, QXC9, QXE4/A, QXQ4/A, SE/A, SME0/A, SXE4/A, SXQ4/A, VX16/A, VX8/A, VXE8/A	
	91424-Z5T-013	-	1	-	-	2016864	HA2/A, HX26/A, LXQ4/A, PKT2/A, PKX2/A, QA2/A, QAE2/A, QAE6/A, QAH2/A, QAP2/A, QE/A, QHB4/A, QKA4/A, QMT2/A, QNE2/A, QNR2/A, QWC/A, QXB7/A, QXC9, QXE4/A, QXQ4/A, SE/A, SME0/A, SXE4/A, SXQ4/A, VX16/A, VX8/A, VXE8/A	
	91424-Z5L-822	TUBE, FUEL, 4.5X580(FKM).....	-	-	1	1	-	QNB2	
	91424-ZBH-851	TUBE, FUEL, 4.2X235(FKM).....	-	-	-	1	-	VVC/A, VWE/A, VWE2/A	
	91424-Z5L-812	TUBE, FUEL, 4.5X165(FKM).....	-	-	-	1	-	VWS	
	91424-ZBH-811	TUBE, FUEL, 4.2X165(FKM).....	-	-	-	1	-	VWS, VWS1	
	91424-Z5L-802	TUBE, FUEL, 4.5X235(FKM).....	-	-	-	1	1077740	VDE2, VVC, VWE, VWE2	
	91424-ZBH-811	TUBE, FUEL, 4.2X165(FKM).....	-	-	-	1	2029558	VWS1/A	
	91424-Z5T-003	TUBE, FUEL, 4.5X235(FKM).....	-	-	-	1	1000707	VDE2, VVC, VWE2	
	91424-ZBH-851	TUBE, FUEL, 4.2X235(FKM).....	-	-	-	1	1077741	VDE2, VVC, VWE, VWE2	
	91424-ZBH-812	TUBE, FUEL, 4.2X165(FKM).....	-	-	-	1	2029559	VWS1/A	
	91424-Z5T-013	TUBE, FUEL, 4.5X235(FKM).....	-	-	-	1	-		
13	94050-08000	NUT, FLANGE, 8MM.....	2	2	-	-	2		

E-17

FUEL TANK

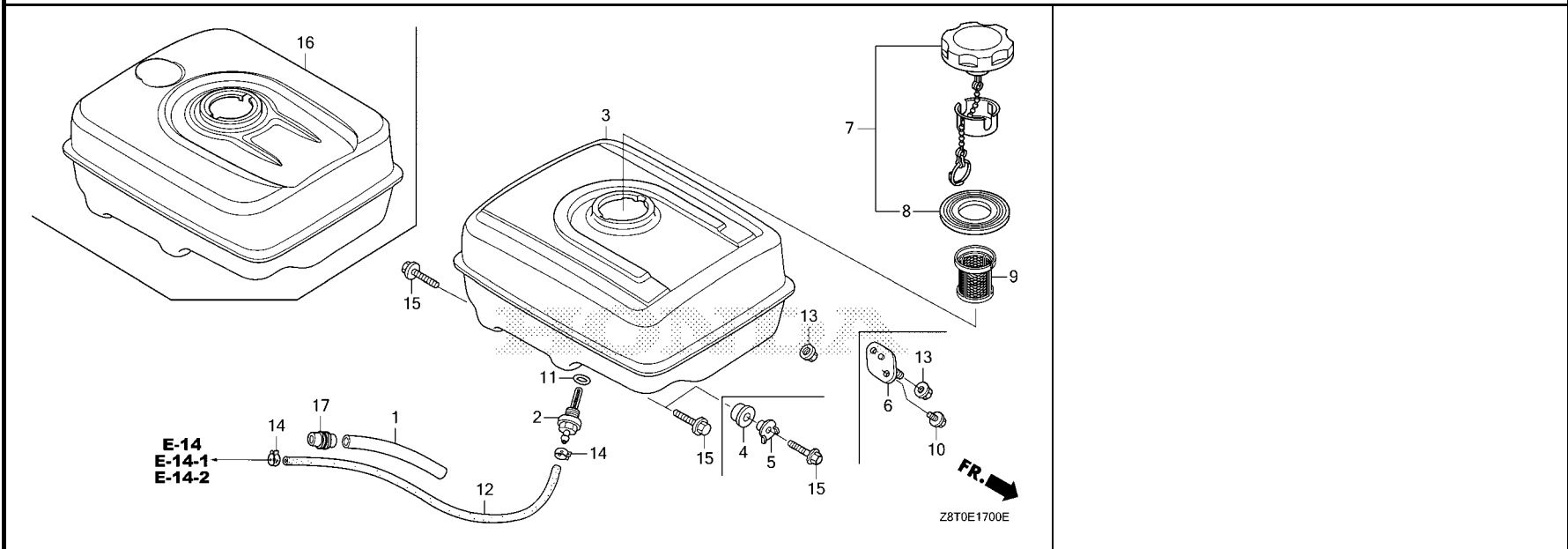

Ref. No.	Part No.	Description	Reqd. QTY					Serial No.	Parts catalogue code
			GX 340 UT1	GX 340 UT2	GX 340 RT1	GX 340 RT2	GX 340 UT2X		
14	95002-40800-08	CLAMP, TUBE(D8).....	2	2	2	1	2	----- HA2, HA2/A, HX26, HX26/A, LX2, LXE4, LXE8, LXQ4, LXQ4/A, LXU, PKT2, PKT2/A, PKX2, PKX2/A, QA2, QA2/A, QA26, QAE2, QAE2/A, QAE6, QAE6/A, QAG, QAH2, QAH2/A, QAP2, QAP2/A, QDW9, QE, QE/A, QHB4, QHB4/A, QHQ4, QKA4, QKA4/A, QMT2, QMT2/A, QNB2, QNE2, QNE2/A, QNR2, QNR2/A, QNR6, QWC, QWC/A, QXB7, QXB7/A, QXB9, QXC4, QXC6, QXC9, QXE4, QXE4/A, QXE6, QXE8, QXQ4, QXQ4/A, QXU, QXU/A, QZA2, QZAV, QZN2, QZX4, SE, SE/A, SE1, SE2, SHQ4, SHQ4/A, SME0, SME0/A, SMX2, SXE4, SXE4/A, SXE8, SXQ4, SXQ4/A, VA2, VC2, VDE2, VW12, VWC, VWC/A, VWE, VWE/A, VWE2, VWE2/A, VWS, VWS1, VWS1/A, VX16, VX16/A, VX8, VX8/A, VXB7, VXB9, VXE2, VXE2/A, VXE7, VXE8, VXE8/A, VXE9	
15	95701-08025-00	BOLT, FLANGE, 8X25.....	2	2	-	-	2		
16	17510-Z5T-000ZB	TANK COMP., FUEL *NH31*.....MCKINLEY WHITE	-	1	-	-	1	----- HA2, HA2/A, HX26, HX26/A, LX2, LXE4, LXQ4, LXQ4/A, LXU, PKT2, PKT2/A, PKX2, PKX2/A, QA2, QA2/A, QAE2, QAE2/A, QAE6, QAE6/A, QAG, QAH2, QAH2/A, QAP2, QAP2/A, QE, QE/A, QHB4, QHB4/A, QHQ4, QKA4, QKA4/A, QMT2, QMT2/A, QNE2, QNE2/A, QNR2, QNR2/A, QXB7, QXB7/A, QXB9, QXC9, QXE4, QXE4/A, QXE6, QXE8, QXQ4, QXQ4/A, QXU, QXU/A, QZA2, QZAV, QZN2, QZX4, SE, SE/A, SE1, SHQ4, SHQ4/A, SME0, SME0/A, SMX2, SXE4, SXE4/A, SXE8, SXQ4, SXQ4/A, VA2, VX16, VX16/A, VX8, VX8/A, VXB7, VXE2, VXE2/A, VXE8, VXE8/A	
	17510-Z5T-000ZA	*NH1*.....BLACK	-	1	-	-	1	----- PKT2, PKT2/A, PKX2, PKX2/A, QA2, QA2/A, QAE2, QAE2/A, QAP2, QAP2/A, QDW9, QKA4, QKA4/A, QMT2, QMT2/A, QNR2, QNR2/A, QWC, QWC/A, QXC9, QXQ4, QXQ4/A, QXU, QXU/A, QZA2, QZAV, QZN2, QZX4, SE, SE/A, SE1, SE2, SHQ4, SHQ4/A, SME0, SME0/A, SMX2, VXB7, VXE2, VXE2/A	
	17510-Z5T-800ZA	*NH1*.....BLACK	-	1	-	-	-	----- VXB9, VXE9	
	17510-Z5T-800ZB	*NH31*.....MCKINLEY WHITE	-	1	-	-	-	----- VXB9, VXE9	
17	90854-ZB3-000	RUBBER, FUEL(9X15X20).....	-	-	-	1	-	----- VWS	



E-19

FLYWHEEL

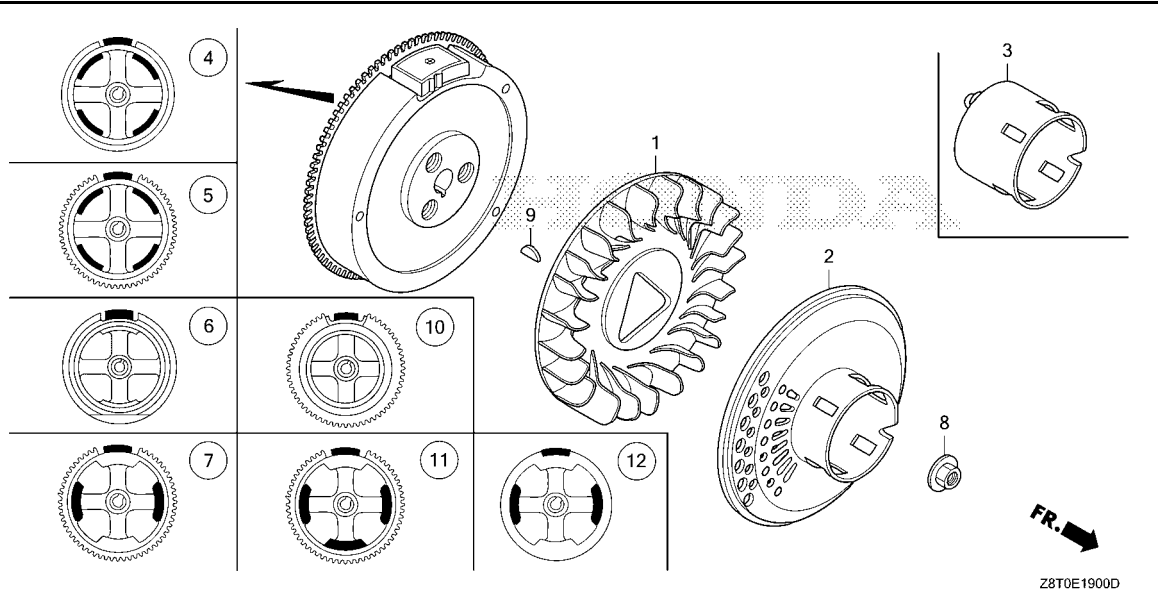

Ref. No. L.O.N. (Relative ref. Number) Description F.R.T.

Ref. No.	Part No.	Description	Reqd. QTY					Serial No.	Parts catalogue code
			GX 340 UT1	GX 340 UT2	GX 340 RT1	GX 340 RT2	GX 340 UT2X		
1	19511-ZE3-000	FAN, COOLING.....	1	1	1	1	1	-----	EDE2, EDE2/A, EDN2, EDN2/A, EDS6, EDS6/A, EDT6, EDT6/A, HA2, HA2/A, HX26, HX26/A, LX2, LXE4, LXE8, LXQ4, LXQ4/A, LXU, PKT2, PKT2/A, PKX2, PKX2/A, QA2, QA2/A, QA26, QAE2, QAE2/A, QAE6, QAE6/A, QAG, QAH2, QAH2/A, QAP2, QAP2/A, QDW9, QE, QE/A, QHB4, QHB4/A, QHQ4, QKA4, QKA4/A, QMT2, QMT2/A, QNB2, QNE2, QNE2/A, QNR2, QNR2/A, QNR6, QWC, QWC/A, QXB7, QXB7/A, QXB9, QXC4, QXC6, QXC9, QXE4, QXE4/A, QXE6, QXE8, QXQ4, QXQ4/A, QXU, QXU/A, QZA2, QZAV, QZN2, QZX4, SE, SE/A, SE1, SE2, SHQ4, SHQ4/A, SME0, SME0/A, SMX2, SXE4, SXE4/A, SXE8, SXQ4, SXQ4/A, VA2, VAD2, VC2, VDE2, VW12, VWC, VWC/A, VWE, VWE/A, VWE2, VWE2/A, VWS, VWS1, VWS1/A, VX16, VX16/A, VX8, VX8/A, VXB7, VXE2, VXE2/A, VXE7, VXE8, VXE8/A, VXB9, VXE9
2	19511-ZK6-880 28450-ZE3-W11	PULLEY COMP., STARTER (SCREEN GRID)	1	1	-	-	-	-----	HA2, HA2/A, HX26, HX26/A, LX2, LXE4, LXE8, LXQ4, LXQ4/A, LXU, QA2, QA2/A, QA26, QAE2, QAE2/A, QAE6, QAE6/A, QAG, QAH2, QAH2/A, QAP2, QAP2/A, QDW9, QE, QE/A, QHB4, QHB4/A, QHQ4, QKA4, QKA4/A, QMT2, QMT2/A, QNB2, QNE2, QNE2/A, QNR2, QNR2/A, QNR6, QWC, QWC/A, QXB7, QXB7/A, QXB9, QXC4, QXC6, QXC9, QXE4, QXE4/A, QXE6, QXE8, QXQ4, QXQ4/A, QXU, QXU/A, QZA2, QZAV, QZN2, QZX4, SE, SE/A, SE1, SE2, SHQ4, SHQ4/A, SME0, SME0/A, SXE4, SXE4/A, SXE8, SXQ4, SXQ4/A, VA2, VAD2, VDE2, VWE2, VWE2/A, VX16, VX16/A, VX8, VX8/A, VXB7, VXE2, VXE2/A, VXE7, VXE8, VXE8/A
3	28451-ZE3-W01	PULLEY, STARTER.....	1	1	1	1	1	-----	EDE2, EDE2/A, EDN2, EDN2/A, EDS6, EDS6/A, EDT6, EDT6/A, PKT2, PKT2/A, PKX2, PKX2/A, SMX2, VC2, VW12, VWC, VWC/A, VWE, VWE/A, VWS, VWS1, VWS1/A, VXB9, VXE9
4	31100-ZE3-U10 31110-Z5T-830	FLYWHEEL COMP.(4POLE).....	1	-	-	-	-	-----	QAG
5	31100-ZE3-W01 31100-ZE3-W21	FLYWHEEL COMP.(SEL-4POLE)..... FLYWHEEL COMP.(SEL-18A).....	1	-	1	-	-	-----	QAG QAE2, QAE6, QNB2, QNE2, SME0 QAH2, QNR2, QNR6



E-19

FLYWHEEL

Ref. No.	Part No.	Description	Reqd. QTY					Serial No.	Parts catalogue code	
			GX 340 UT1	GX 340 UT2	GX 340 RT1	GX 340 RT2	GX 340 UT2X			
(5)	31110-Z5T-840	FLYWHEEL COMP.(SEL-4POLE).....	-	1	-	1	1	-----	QAE2, QAE2/A, QAE6, QAE6/A, QNB2, QNE2, QNE2/A, SE2, SME0, SME0/A	
	31110-Z5T-860	FLYWHEEL COMP.(SEL-18A).....	-	1	-	-	1	-----	QAH2, QAH2/A, QNR2, QNR2/A	
6	31100-ZE3-701	FLYWHEEL COMP.	1	-	1	-	-	-----	HA2, HX26, LX2, LXQ4, LXU, PKT2, QA2, QA26, QAP2, QDW9, QE, QHB4, QHQ4, QKA4, QXB7, QXB9, QXC4, QXC6, QXC9, QXQ4, QXU, SE, SHQ4, SXQ4, VA2, VAD2, VC2, VDE2, VW12, VWC, VX16, VX8, VXB7, VXB9	
	31110-Z5T-000	-	1	-	1	1	-----	EDT6, EDT6/A, HA2, HA2/A, HX26, HX26/A, LX2, LXQ4, LXQ4/A, LXU, PKT2, PKT2/A, PKX2, PKX2/A, QA2, QA2/A, QAP2, QAP2/A, QDW9, QE, QE/A, QHB4, QHB4/A, QHQ4, QKA4, QKA4/A, QMT2, QMT2/A, QXB7, QXB7/A, QXB9, QXC9, QXQ4, QXQ4/A, QXU, QXU/A, SE, SE/A, SE1, SHQ4, SHQ4/A, SMX2, SXQ4, SXQ4/A, VA2, VDE2, VWC, VWC/A, VWS, VWS1, VWS1/A, VX16, VX16/A, VX8, VX8/A, VXB7, VXB9	
7	31100-ZE3-722	FLYWHEEL COMP.(SEL-LAMP).....	1	-	1	-	-	-----	LXE4, LXE8, QXE4, QXE6, QXE8, SXE4, SXE8, VWE, VWE2, VXE2, VXE7, VXE8, VXE9	
	31110-Z5T-820	-	1	-	1	1	-----	EDE2, EDE2/A, EDS6, EDS6/A, LXE4, QXE4, QXE4/A, QXE6, QXE8, SXE4, SXE4/A, SXE8, VWE, VWE/A, VWE2, VWE2/A, VXE2, VXE2/A, VXE8, VXE8/A, VXE9	
8	90201-ZE3-790	NUT, SPECIAL, 16MM.....	1	-	1	-	-	-----	EDE2, EDE2/A, EDN2, EDN2/A, EDS6, EDS6/A, EDT6, EDT6/A, HA2/A, HX26/A, LXQ4/A, PKT2/A, PKX2, PKX2/A, QA2/A, QAE2/A, QAE6/A, QAH2/A, QAP2/A, QDW9, QE/A, QHB4/A, QKA4, QKA4/A, QMT2, QMT2/A, QNE2/A, QNR2/A, QWC, QWC/A, QXB7/A, QXC9, QXE4/A, QXQ4/A, QXU/A, SE/A, SE1, SE2, SHQ4/A, SME0/A, SMX2, SXE4/A, SXQ4/A, VWC/A, VWE/A, VWE2/A, VWS, VWS1, VWS1/A, VX16/A, VX8/A, VXE2/A, VXE8/A	
	90201-ZE3-790	-	1	-	-	-	1004519	-----	HA2, HX26, LX2, LXE4, LXQ4, LXU, PKT2, QA2, QAE2, QAE6, QAG, QAH2, QAP2, QE, QHB4, QHQ4, QNE2, QNR2, QXB7, QXB9, QXE4, QXE6, QXE8, QXQ4, QXU, QZA2, QZAV, QZN2, QZX4, SE, SHQ4, SME0, SXE4, SXE8, SXQ4, VA2, VX16, VX8, VXB7, VXB9, VXE2, VXE8, VXE9
	90201-ZE3-V00	-	1	-	-	-	1004520	-----	HA2, HX26, LX2, LXE4, LXQ4, LXU, PKT2, QA2, QAE2, QAE6, QAG, QAH2, QAP2, QE, QHB4, QHQ4, QNE2, QNR2, QXB7, QXB9, QXE4, QXE6, QXE8, QXQ4, QXU, QZA2, QZAV, QZN2, QZX4, SE, SHQ4, SME0, SXE4, SXE8, SXQ4, VA2, VX16, VX8, VXB7, VXB9, VXE2, VXE8, VXE9
	90201-ZE3-790	-	-	-	-	1	1004954	-----	QNB2, VDE2, VWC, VWE, VWE2
	90201-ZE3-V00	-	-	-	-	1	1004955	-----	QNB2, VDE2, VWC, VWE, VWE2
9	90741-ZE2-000	KEY, SPECIAL WOODRUFF, 25X18·	1	1	1	1	1	-----		
10	31110-Z5T-W41	FLYWHEEL COMP.(SEL-16POLE)···	-	1	-	-	-	-----	QZN2	
11	31110-Z5T-W00	FLYWHEEL COMP.(SEL).....	-	1	-	-	-	-----	QZA2, QZAV, QZX4	
12	31110-Z5T-810	FLYWHEEL COMP.(LAMP).....	-	1	-	1	1	-----	EDN2, EDN2/A, QWC, QWC/A	



E-20

IGNITION COIL

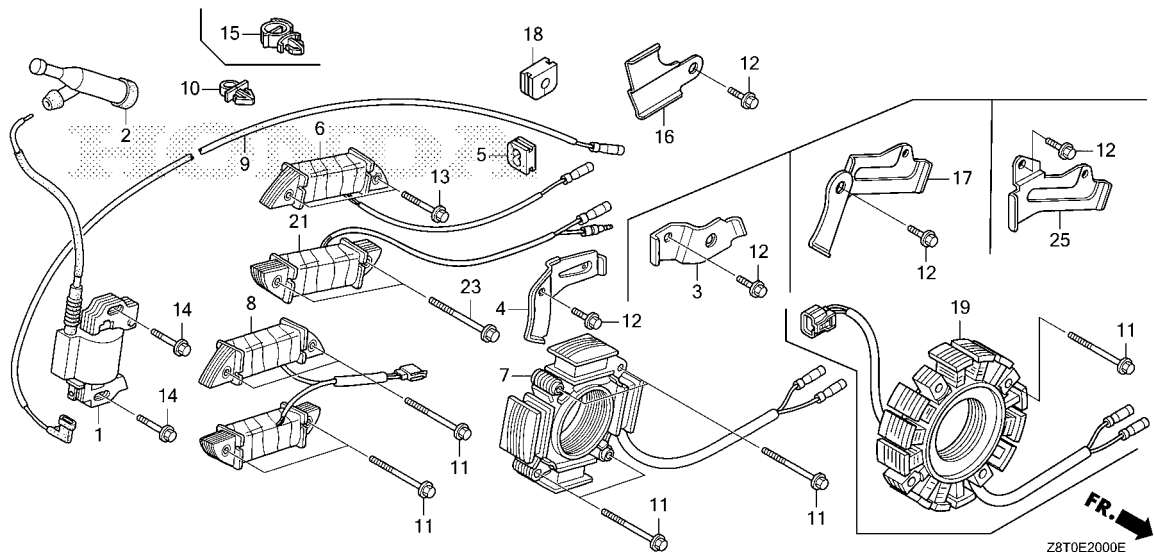

Ref. L.O.N. (Relative ref. Number) F.R.T.
No. Description

Ref. No.	Part No.	Description	Reqd. QTY					Serial No.	Parts catalogue code
			GX 340 UT1	GX 340 UT2	GX 340 RT1	GX 340 RT2	GX 340 UT2X		
1	30500-Z1C-023	COIL ASSY., IGNITION.....	1	-	1	-	-	-----	EDE2, EDE2/A, EDN2, EDN2/A, EDS6, EDS6/A, EDT6, EDT6/A, HA2, HA2/A, HX26, HX26/A, LXQ4, LXQ4/A, PKT2, PKT2/A, PKX2, PKX2/A, QA2, QA2/A, QAE2, QAE2/A, QAE6, QAE6/A, QAH2, QAH2/A, QAP2, QAP2/A, QE, QE/A, QHB4, QHB4/A, QKA4, QKA4/A, QMT2, QMT2/A, QNE2, QNE2/A, QNR2, QNR2/A, QWC, QWC/A, QXB7, QXB7/A, QXC9, QXE4, QXE4/A, QXQ4, QXQ4/A, QXU, QXU/A, SE, SE/A, SE1, SE2, SME0, SME0/A, SXE4, SXE4/A, SXQ4, SXQ4/A, VWC, VWC/A, VWE, VWE/A, VWE2, VWE2/A, VWS1, VWS1/A, VX16, VX16/A, VX8, VX8/A, VXE2, VXE2/A, VXE8, VXE8/A
	30500-Z5T-003	-	1	-	1	1		
	30500-Z5T-004	COIL ASSY., IGNITION(IIDA)...	-	1	-	1	1		
2	30700-Z1C-811	CAP ASSY., NOISE SUPPRESSOR (NGK Y-EZD)	1	-	1	-	-	-----	EDE2, EDE2/A, EDN2, EDN2/A, EDS6, EDS6/A, EDT6, EDT6/A, HA2, HA2/A, HX26, HX26/A, LX2, LXE4, LXQ4, LXQ4/A, LXU, PKT2, PKT2/A, PKX2, PKX2/A, QA2, QA2/A, QAE2, QAE2/A, QAE6, QAE6/A, QAH2, QAH2/A, QAP2, QAP2/A, QDW9, QE, QE/A, QHB4, QHB4/A, QHQ4, QKA4, QKA4/A, QMT2, QMT2/A, QNE2, QNE2/A, QNR2, QNR2/A, QWC, QWC/A, QXB7, QXB7/A, QXB9, QXC9, QXE4, QXE4/A, QXE6, QXE8, QXQ4, QXQ4/A, QXU, QXU/A, SE, SE/A, SE1, SE2, SHQ4, SHQ4/A, SME0, SME0/A, SMX2, SXE4, SXE4/A, SXE8, SXQ4, SXQ4/A, VA2, VDE2, VWC, VWC/A, VWE, VWE/A, VWE2, VWE2/A, VWS, VWS1, VWS1/A, VX16, VX16/A, VX8, VX8/A, VXB7, VXB9, VXE2, VXE2/A, VXE8, VXE8/A
	30700-Z1C-813	-	1	-	1	1		
	30700-Z1C-811	-	1	-	-	-		
3	31511-ZE2-W00	CLAMPER, CORD	1	1	-	-	1	-----	QAG, QZA2, QZAV, QZN2, QZX4, VXE9
4	31511-ZE3-000	CLAMPER, CORD	1	1	1	1	1	-----	QNB2
								-----	QAH2, QAH2/A, QNR2, QNR2/A, QNR6
								-----	EDE2, EDE2/A, EDN2, EDN2/A, EDS6, EDS6/A, LXE4, LXE8, QAE2, QAE2/A, QAE6, QAE6/A, QAG, QNB2, QNE2, QNE2/A, QWC, QWC/A, QXE4, QXE4/A, QXE6, QXE8, SE2, SME0, SME0/A, SXE4, SXE4/A, SXE8, VWE, VWE/A, VWE2, VWE2/A, VXE2, VXE2/A, VXE7, VXE8, VXE8/A, VXE9

E-20

IGNITION COIL

Ref. No.	Part No.	Description	Reqd. QTY					Serial No.	Parts catalogue code
			GX 340 UT1	GX 340 UT2	GX 340 RT1	GX 340 RT2	GX 340 UT2X		
5	31512-ZE2-000	GROMMET, CORD	1	1	1	1	1		
6	31630-ZE1-013	COIL ASSY., CHARGE(1A)	1	1	1	1	1	----- EDS6, EDS6/A, LXE4, LXE8, QWC, QWC/A, QXE4, QXE4/A, QXE6, QXE8, SXE4, SXE4/A, SXE8, VWE, VWE/A, VWE2, VWE2/A, VXE2, VXE2/A, VXE7, VXE8, VXE8/A, VXE9	
	31630-ZE2-842	COIL ASSY., CHARGE(3A)	1	1	-	-	1	----- QAE2, QAE2/A, QAE6, QAE6/A	
	30595-Z5T-W01	COIL ASSY., POWER	-	1	-	-	-	----- QZA2, QZAV, QZX4	
	31510-ZE1-811	COIL ASSY., LAMP(12V/25W)	-	-	-	1	-	----- EDE2, EDE2/A, EDN2, EDN2/A	
7	31630-ZE2-W01	COIL ASSY., CHARGE(12V/18A)	1	-	-	-	-	----- QAH2, QNR2, QNR6	
	31630-Z1C-003	COIL ASSY., CHARGE(12V-17A)	-	1	-	-	1	----- QAH2, QAH2/A, QNR2, QNR2/A	
8	31630-ZE2-861	COIL ASSY., CHARGE(10A)	1	1	1	1	1	----- QAG, QNB2, QNE2, QNE2/A, SE2, SME0, SME0/A	
9	36101-ZE2-701	CORD, STOP SWITCH(430MM)	1	-	1	-	-	----- HA2, HX26, LX2, LXE4, LXE8, LXQ4, LXU, PKT2, QA2, QA26, QAE2, QAE6, QAG, QAH2, QAP2, QDW9, QE, QHB4, QHQ4, QKA4, QNB2, QNE2, QNR2, QNR6, QXB7, QXB9, QXC4, QXC6, QXC9, QXE4, QXE6, QXE8, QXQ4, QXU, SE, SHQ4, SME0, SXE4, SXE8, SXQ4, VA2, VAD2, VC2, VDE2, VW12, VWE2, VX16, VXB7, VXB9, VXE2, VXE7, VXE8, VXE9	
	36101-ZE3-800	CORD, STOP SWITCH(470MM)	-	-	1	-	-	----- VWC, VWE	
10	36103-ZE1-000	HOLDER, STOP SWITCH CORD	1	-	1	1	-	----- LXE4, LXE8, QAE2, QAE6, QE, QHB4, QHQ4, QNE2, QNR2, QNR6, QXE4, QXE6, QXE8, SE, SHQ4, SME0, SXE4, SXE8, VWE2, VWE2/A, VXE2, VXE7, VXE8, VXE9	
			-	1	-	-	1	----- LXE4, QAE2, QAE2/A, QAE6, QAE6/A, QNE2, QNE2/A, QNR2, QNR2/A, QXE4, QXE4/A, QXE6, QXE8, SME0, SME0/A, SXE4, SXE4/A, SXE8, VXE2, VXE2/A, VXE8, VXE8/A, VXE9	
11	90012-888-000	BOLT, FLANGE, 6X40(CT200)	4	4	4	4	4	----- QAG, QAH2, QAH2/A, QNB2, QNE2, QNE2/A, QNR2, QNR2/A, QNR6, QZN2, SE2, SME0, SME0/A	
12	90013-883-000	BOLT, FLANGE, 6X12(CT200)	1	1	1	1	-	----- EDE2, EDE2/A, EDN2, EDN2/A, EDS6, EDS6/A, LXE4, LXE8, QAE2, QAE2/A, QAE6, QAE6/A, QAG, QAH2, QAH2/A, QNB2, QNE2, QNE2/A, QNR2, QNR2/A, QNR6, QWC, QWC/A, QXE4, QXE4/A, QXE6, QXE8, SE2, SME0, SME0/A, SXE4, SXE4/A, SXE8, VWE, VWE/A, VWE2, VWE2/A, VXE2, VXE2/A, VXE7, VXE8, VXE8/A, VXE9	
			-	2	-	-	-	----- QZA2, QZAV, QZN2, QZX4	
			-	-	-	-	1	----- QAE2, QAE6, QAH2, QNE2, QNR2, QWC, QXE4, SE2, SME0, SXE4, VXE8	
13	90014-ZE6-000	BOLT, FLANGE, 6X35(CT200)	2	2	2	2	2	----- EDS6, EDS6/A, LXE4, LXE8, QWC, QWC/A, QXE4, QXE4/A, QXE6, QXE8, SXE4, SXE4/A, SXE8, VWE, VWE/A, VWE2, VWE2/A, VXE2, VXE2/A, VXE7, VXE8, VXE8, VXE8/A, VXE9	
	90012-888-000	BOLT, FLANGE, 6X40(CT200)	2	2	-	2	2	----- EDE2, EDE2/A, EDN2, EDN2/A, QAE2, QAE2/A, QAE6, QAE6/A	
	90014-ZE6-000	BOLT, FLANGE, 6X35(CT200)	-	2	-	-	-	----- 1002961 QZA2, QZAV, QZX4	
14	90015-883-000	BOLT, FLANGE, 6X28(CT200)	2	2	2	2	2	----- 1002962 QZA2, QZAV, QZX4	
15	90684-ZA0-601	CLIP, HARNESS	1	-	1	1	-	----- EDN2, EDN2/A, EDT6, EDT6/A, HA2, HX26, LX2, LXQ4, LXU, PKT2, QA2, QA26, QAG, QAH2, QAP2, QDW9, QKA4, QXB7, QXB9, QXC4, QXC6, QXC9, QXQ4, QXU, SXQ4, VA2, VAD2, VC2, VDE2, VW12, VWC, VWC/A, VWS, VWS1, VWS1/A, VX16, VX8, VXB7, VXB9	
			-	1	-	-	1	----- HA2, HA2/A, HX26, HX26/A, LX2, LXQ4, LXQ4/A, LXU, PKT2, PKT2/A, PKX2, PKX2/A, QA2, QA2/A, QAG, QAH2, QAH2/A, QAP2, QAP2/A, QDW9, QE, QE/A, QHB4, QHB4/A, QHQ4, QKA4, QKA4/A, QMT2, QMT2/A, QWC, QWC/A, QXB7, QXB7/A, QXB9, QXC9, QXQ4, QXQ4/A, QXU, QXU/A, SE, SE/A, SE1, SHQ4, SHQ4/A, SMX2, SXQ4, SXQ4/A, VA2, VX16, VX16/A, VX8, VX8/A, VXB7, VXB9	
16	30596-Z5T-W00	BRACKET B, HARNESS	-	1	-	-	-	----- QZA2, QZAV, QZN2, QZX4	
17	31511-Z5T-W00	CLAMPER, CORD	-	1	-	-	-	----- QZA2, QZAV, QZX4	
18	31512-Z5T-W00	GROMMET, CORD	-	1	-	-	-	----- QZA2, QZAV, QZN2, QZX4	
19	31630-Z5T-W21	COIL ASSY., CHARGE(12A)	-	1	-	-	-	----- QZN2	
21	31630-Z5T-W11	COIL ASSY., CHARGE(2.9A)	-	1	-	-	-	----- QZA2, QZAV	
	31630-Z5T-W01	COIL ASSY., CHARGE(0.9A)	-	1	-	-	-	----- QZX4	
	31510-ZE3-003	COIL ASSY., LAMP(12V/25W)	-	-	-	1	-	----- EDE2, EDE2/A, EDN2, EDN2/A	



E-20

IGNITION COIL

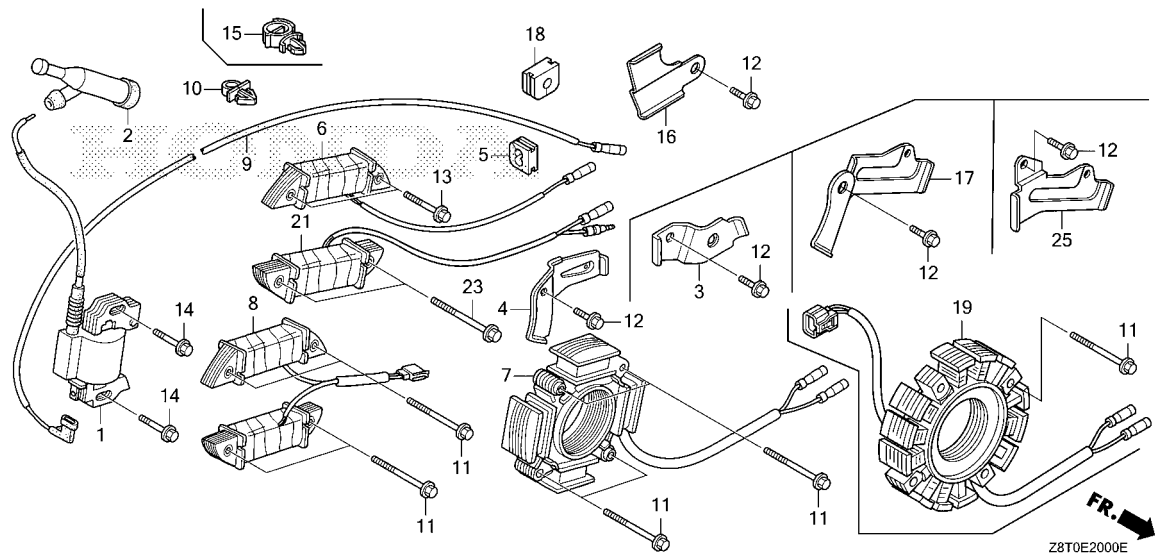

Ref. No.	Part No.	Description	Reqd. QTY					Serial No.	Parts catalogue code
			GX 340 UT1	GX 340 UT2	GX 340 RT1	GX 340 RT2	GX 340 UT2X		
23	90012-888-000	BOLT, FLANGE, 6X40(CT200).....	-	2	-	2	-	EDE2, EDE2/A, EDN2, EDN2/A, QZA2, QZAV	
	90014-ZE6-000	BOLT, FLANGE, 6X35(CT200).....	-	2	-	-	-	QZX4	
25	31511-Z5T-W10	CLAMPER, CORD	-	1	-	-	-	QZN2	

2

E-20-10

ELECTRONIC CONTROL UNIT

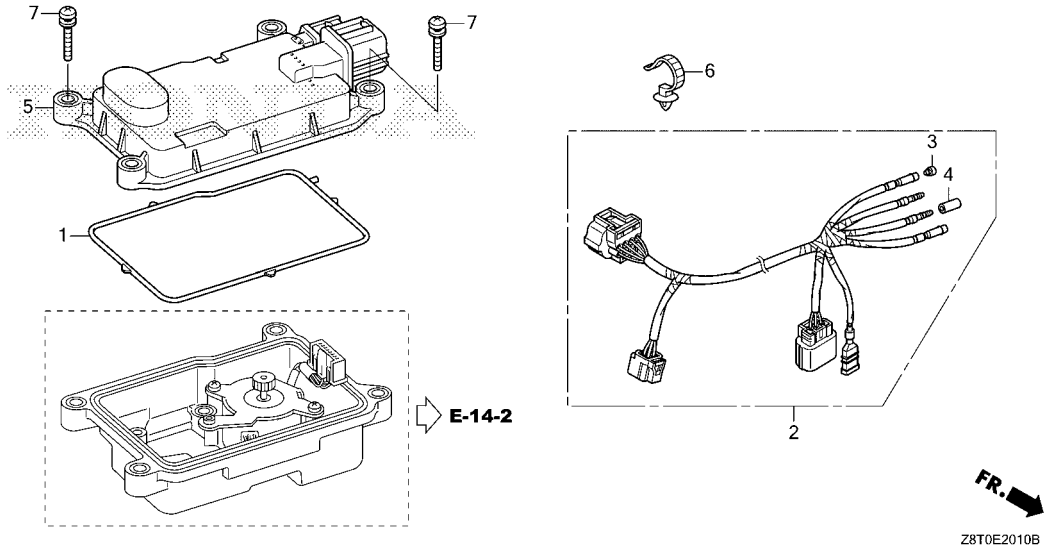

Ref. L.O.N. (Relative ref. Number) F.R.T.
 No. Description

Ref. No.	Part No.	Description	Reqd. QTY					Serial No.	Parts catalogue code
			GX 340 UT1	GX 340 UT2	GX 340 RT1	GX 340 RT2	GX 340 UT2X		
1	16755-Z5T-W00	SEAL, ELECTRONIC CONTROL UNIT COVER	-	1	-	-	-	-----	QZA2, QZAV, QZN2, QZX4
2	32110-Z5T-W00	HARNESS ASSY., ENGINE WIRE	-	1	-	-	-	-----	QZA2, QZN2, QZX4
	32110-Z5T-W10	-	1	-	-	-	-----	QZAV
3	32823-ZV5-003	PLUG, INNER CONNECTOR	-	1	-	-	-	-----	QZA2, QZAV, QZN2, QZX4
4	32824-ZV5-003	PLUG, OUTER CONNECTOR	-	1	-	-	-	-----	QZA2, QZAV, QZN2, QZX4
5	34750-Z5T-W71	CONTROL UNIT, ELECTRONIC	-	1	-	-	-	1091694	QZN2
	34750-Z5T-W61	-	1	-	-	-	1091758	QZA2, QZX4
	34750-Z5T-W11	-	1	-	-	-	1091790	QZAV
	34750-Z5T-W72	-	1	-	-	-	1091695	QZN2
	34750-Z5T-W62	-	1	-	-	-	1091759	QZA2, QZX4
	34750-Z5T-W82	-	1	-	-	-	1091791	QZAV
6	91541-S0A-003	CLIP, HARNESS BAND(BLACK) (145MM)	-	1	-	-	-	-----	QZA2, QZAV, QZN2, QZX4
7	93891-04020-07	SCREW-WASHER, 4X20	-	4	-	-	-	-----	QZA2, QZAV, QZN2, QZX4



E-21

STARTER MOTOR(1)

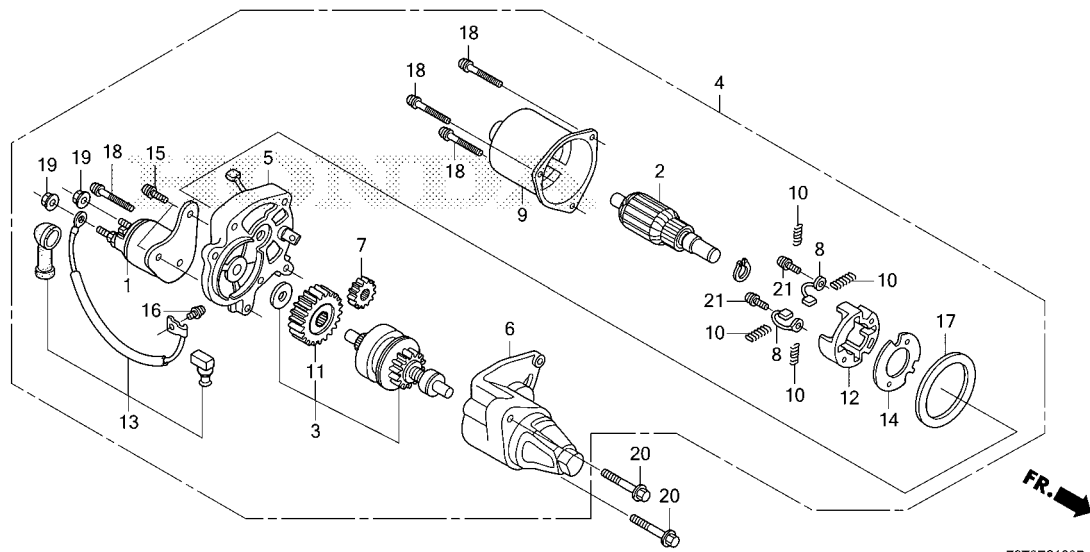

Z8T0E2100B

Ref. No. L.O.N. (Relative ref. Number) Description F.R.T.

Ref. No.	Part No.	Description	Reqd. QTY					Serial No.	Parts catalogue code
			GX 340 UT1	GX 340 UT2	GX 340 RT1	GX 340 RT2	GX 340 UT2X		
1	31204-ZA0-003	CONTACTOR ASSY.	1	1	1	1	1	----- EDE2, EDE2/A, EDS6, EDS6/A, LXE4, LXE8, QAE2, QAE2/A, QAE6, QAE6/A, QNB2, QNE2, QNE2/A, QNR2, QNR2/A, QNR6, QXE4, QXE4/A, QXE6, QXE8 SE2, SME0, SME0/A, SXE4, SXE4/A, SXE8, VWE, VWE/A, VWE2, VWE2/A, VXE2, VXE2/A, VXE7, VXE8, VXE8/A, VXE9	
2	31206-ZE3-003	ARMATURE COMP.	1	1	1	1	1	----- EDE2, EDE2/A, EDS6, EDS6/A, LXE4, LXE8, QAE2, QAE2/A, QAE6, QAE6/A, QNB2, QNE2, QNE2/A, QNR2, QNR2/A, QNR6, QXE4, QXE4/A, QXE6, QXE8 SE2, SME0, SME0/A, SXE4, SXE4/A, SXE8, VWE, VWE/A, VWE2, VWE2/A, VXE2, VXE2/A, VXE7, VXE8, VXE8/A, VXE9	
3	31207-ZE3-003	CLUTCH COMP., OVERRUNNING	1	1	1	1	-	----- EDE2, EDS6, LXE4, LXE8, QAE2, QAE6, QNB2, QNE2, QNR2, QNR6, QXE4, QXE6, QXE8, SME0, SXE4, SXE8, VWE, VWE2, VXE2, VXE7, VXE8, VXE9	
	31208-ZE3-003	-	1	-	1	-	2007625 ----- EDE2/A, EDS6/A, QAE2/A, QAE6/A, QNE2/A, QNR2/A, QXE4/A, SME0/A, SXE4/A, VWE/A, VWE2/A, VXE2/A, VXE8/A	
			-	1	-	1	-	2007626 ----- EDE2/A, EDS6/A, QAE2/A, QAE6/A, QNE2/A, QNR2/A, QXE4/A, SME0/A, SXE4/A, VWE/A, VWE2/A, VXE2/A, VXE8/A	
4	31210-ZE3-023	MOTOR UNIT, STARTER	1	1	1	1	-	----- QAE2, QAE6, QNE2, QNR2, QXE4, SE2, SME0, SXE4, VXE8	
			-	1	-	1	-	2007625 ----- EDE2, EDS6, LXE4, LXE8, QAE2, QAE6, QNB2, QNE2, QNR2, QNR6, QXE4, QXE6, QXE8, SME0, SXE4, SXE8, VWE, VWE2, VXE2, VXE7, VXE8, VXE9	
	31210-ZE3-033	-	1	-	1	-	2007626 ----- EDE2/A, EDS6/A, QAE2/A, QAE6/A, QNE2/A, QNR2/A, QXE4/A, SME0/A, SXE4/A, VWE/A, VWE2/A, VXE2/A, VXE8/A	
			-	1	-	1	-	----- EDE2/A, EDS6/A, QAE2/A, QAE6/A, QNE2/A, QNR2/A, QXE4/A, SME0/A, SXE4/A, VWE/A, VWE2/A, VXE2/A, VXE8/A	
5	31211-ZE2-003	BRACKET, CENTER	1	1	1	1	1	----- QAE2, QAE6, QNE2, QNR2, QXE4, SE2, SME0, SXE4, VXE8	
			-	-	-	-	1	----- EDE2, EDE2/A, EDS6, EDS6/A, LXE4, LXE8, QAE2, QAE2/A, QAE6, QAE6/A, QNB2, QNE2, QNE2/A, QNR2, QNR2/A, QNR6, QXE4, QXE4/A, QXE6, QXE8 SE2, SME0, SME0/A, SXE4, SXE4/A, SXE8, VWE, VWE/A, VWE2, VWE2/A, VXE2, VXE2/A, VXE7, VXE8, VXE8/A, VXE9	



E-21

STARTER MOTOR(1)

Ref. No.	Part No.	Description	Reqd. QTY					Serial No.	Parts catalogue code
			GX 340 UT1	GX 340 UT2	GX 340 RT1	GX 340 RT2	GX 340 UT2X		
6	31212-ZE3-003	BRACKET, FR.	1	1	1	1	1	-----	EDE2, EDE2/A, EDS6, EDS6/A, LXE4, LXE8, QAE2, QAE2/A, QAE6, QAE6/A, QNB2, QNE2, QNE2/A, QNR2, QNR2/A, QNR6, QXE4, QXE4/A, QXE6, QXE8 SE2, SME0, SME0/A, SXE4, SXE4/A, SXE8, VWE, VWE/A, VWE2, VWE2/A, VXE2, VXE2/A, VXE7, VXE8, VXE8/A, VXE9
7	31213-ZE2-003	GEAR, DRIVE PINION	1	1	1	1	1	-----	EDE2, EDE2/A, EDS6, EDS6/A, LXE4, LXE8, QAE2, QAE2/A, QAE6, QAE6/A, QNB2, QNE2, QNE2/A, QNR2, QNR2/A, QNR6, QXE4, QXE4/A, QXE6, QXE8 SE2, SME0, SME0/A, SXE4, SXE4/A, SXE8, VWE, VWE/A, VWE2, VWE2/A, VXE2, VXE2/A, VXE7, VXE8, VXE8/A, VXE9
8	31215-ZE2-003	BRUSH	2	2	2	2	2	-----	EDE2, EDE2/A, EDS6, EDS6/A, LXE4, LXE8, QAE2, QAE2/A, QAE6, QAE6/A, QNB2, QNE2, QNE2/A, QNR2, QNR2/A, QNR6, QXE4, QXE4/A, QXE6, QXE8 SE2, SME0, SME0/A, SXE4, SXE4/A, SXE8, VWE, VWE/A, VWE2, VWE2/A, VXE2, VXE2/A, VXE7, VXE8, VXE8/A, VXE9
9	31218-ZE3-003	YOKE COMP.	1	1	1	1	1	-----	EDE2, EDE2/A, EDS6, EDS6/A, LXE4, LXE8, QAE2, QAE2/A, QAE6, QAE6/A, QNB2, QNE2, QNE2/A, QNR2, QNR2/A, QNR6, QXE4, QXE4/A, QXE6, QXE8 SE2, SME0, SME0/A, SXE4, SXE4/A, SXE8, VWE, VWE/A, VWE2, VWE2/A, VXE2, VXE2/A, VXE7, VXE8, VXE8/A, VXE9
10	31219-ZE2-003	SPRING, BRUSH RETURN	4	4	4	4	4	-----	EDE2, EDE2/A, EDS6, EDS6/A, LXE4, LXE8, QAE2, QAE2/A, QAE6, QAE6/A, QNB2, QNE2, QNE2/A, QNR2, QNR2/A, QNR6, QXE4, QXE4/A, QXE6, QXE8 SE2, SME0, SME0/A, SXE4, SXE4/A, SXE8, VWE, VWE/A, VWE2, VWE2/A, VXE2, VXE2/A, VXE7, VXE8, VXE8/A, VXE9
11	31222-ZE3-791	GEAR, REDUCTION	1	1	1	1	1	-----	EDE2, EDE2/A, EDS6, EDS6/A, LXE4, LXE8, QAE2, QAE2/A, QAE6, QAE6/A, QNB2, QNE2, QNE2/A, QNR2, QNR2/A, QNR6, QXE4, QXE4/A, QXE6, QXE8 SE2, SME0, SME0/A, SXE4, SXE4/A, SXE8, VWE, VWE/A, VWE2, VWE2/A, VXE2, VXE2/A, VXE7, VXE8, VXE8/A, VXE9
12	31231-ZE2-003	HOLDER, BRUSH	1	1	1	1	1	-----	EDE2, EDE2/A, EDS6, EDS6/A, LXE4, LXE8, QAE2, QAE2/A, QAE6, QAE6/A, QNB2, QNE2, QNE2/A, QNR2, QNR2/A, QNR6, QXE4, QXE4/A, QXE6, QXE8 SE2, SME0, SME0/A, SXE4, SXE4/A, SXE8, VWE, VWE/A, VWE2, VWE2/A, VXE2, VXE2/A, VXE7, VXE8, VXE8/A, VXE9
13	31232-ZE3-003	WIRE, WATER COVER	1	1	1	1	1	-----	EDE2, EDE2/A, EDS6, EDS6/A, LXE4, LXE8, QAE2, QAE2/A, QAE6, QAE6/A, QNB2, QNE2, QNE2/A, QNR2, QNR2/A, QNR6, QXE4, QXE4/A, QXE6, QXE8 SE2, SME0, SME0/A, SXE4, SXE4/A, SXE8, VWE, VWE/A, VWE2, VWE2/A, VXE2, VXE2/A, VXE7, VXE8, VXE8/A, VXE9
14	31233-ZE2-003	INSULATOR	1	1	1	1	1	-----	EDE2, EDE2/A, EDS6, EDS6/A, LXE4, LXE8, QAE2, QAE2/A, QAE6, QAE6/A, QNB2, QNE2, QNE2/A, QNR2, QNR2/A, QNR6, QXE4, QXE4/A, QXE6, QXE8 SE2, SME0, SME0/A, SXE4, SXE4/A, SXE8, VWE, VWE/A, VWE2, VWE2/A, VXE2, VXE2/A, VXE7, VXE8, VXE8/A, VXE9
15	90007-ZE2-003	BOLT-WASHER, 5X14	2	2	2	2	2	-----	EDE2, EDE2/A, EDS6, EDS6/A, LXE4, LXE8, QAE2, QAE2/A, QAE6, QAE6/A, QNB2, QNE2, QNE2/A, QNR2, QNR2/A, QNR6, QXE4, QXE4/A, QXE6, QXE8 SE2, SME0, SME0/A, SXE4, SXE4/A, SXE8, VWE, VWE/A, VWE2, VWE2/A, VXE2, VXE2/A, VXE7, VXE8, VXE8/A, VXE9
16	90110-ZE2-003	SCREW-WASHER, 4X6	1	1	1	1	1	-----	EDE2, EDE2/A, EDS6, EDS6/A, LXE4, LXE8, QAE2, QAE2/A, QAE6, QAE6/A, QNB2, QNE2, QNE2/A, QNR2, QNR2/A, QNR6, QXE4, QXE4/A, QXE6, QXE8 SE2, SME0, SME0/A, SXE4, SXE4/A, SXE8, VWE, VWE/A, VWE2, VWE2/A, VXE2, VXE2/A, VXE7, VXE8, VXE8/A, VXE9
17	91601-ZE2-003	PACKING	1	1	1	1	1	-----	EDE2, EDE2/A, EDS6, EDS6/A, LXE4, LXE8, QAE2, QAE2/A, QAE6, QAE6/A, QNB2, QNE2, QNE2/A, QNR2, QNR2/A, QNR6, QXE4, QXE4/A, QXE6, QXE8 SE2, SME0, SME0/A, SXE4, SXE4/A, SXE8, VWE, VWE/A, VWE2, VWE2/A, VXE2, VXE2/A, VXE7, VXE8, VXE8/A, VXE9
18	93892-05032-18	SCREW-WASHER, 5X32	4	4	4	4	4	-----	EDE2, EDE2/A, EDS6, EDS6/A, LXE4, LXE8, QAE2, QAE2/A, QAE6, QAE6/A, QNB2, QNE2, QNE2/A, QNR2, QNR2/A, QNR6, QXE4, QXE4/A, QXE6, QXE8 SE2, SME0, SME0/A, SXE4, SXE4/A, SXE8, VWE, VWE/A, VWE2, VWE2/A, VXE2, VXE2/A, VXE7, VXE8, VXE8/A, VXE9
19	94070-06080	NUT-WASHER, 6MM	2	2	2	2	2	-----	EDE2, EDE2/A, EDS6, EDS6/A, LXE4, LXE8, QAE2, QAE2/A, QAE6, QAE6/A, QNB2, QNE2, QNE2/A, QNR2, QNR2/A, QNR6, QXE4, QXE4/A, QXE6, QXE8 SE2, SME0, SME0/A, SXE4, SXE4/A, SXE8, VWE, VWE/A, VWE2, VWE2/A, VXE2, VXE2/A, VXE7, VXE8, VXE8/A, VXE9



E-21

STARTER MOTOR(1)

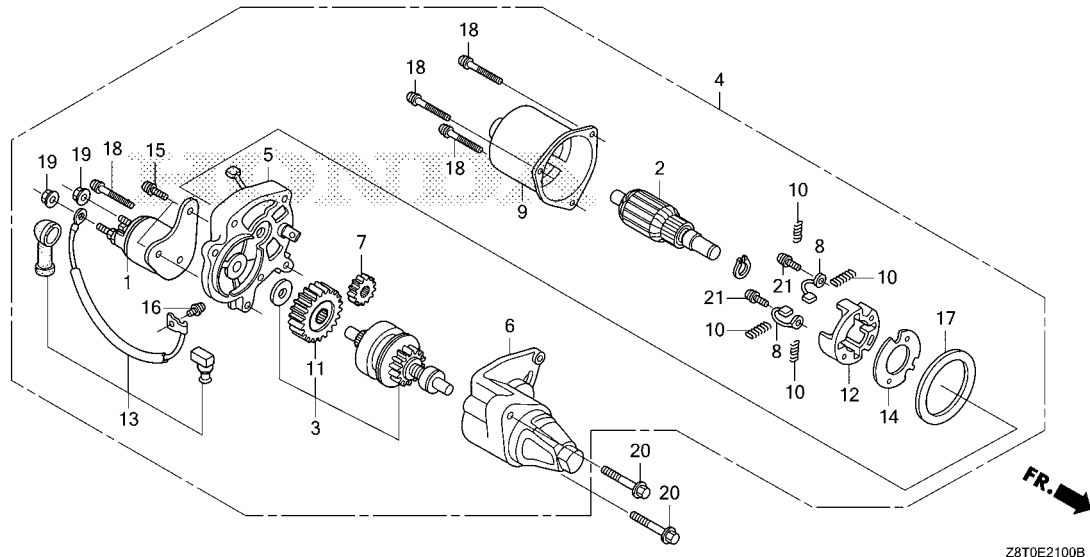

Ref. No.	Part No.	Description	Reqd. QTY					Serial No.	Parts catalogue code
			GX 340 UT1	GX 340 UT2	GX 340 RT1	GX 340 RT2	GX 340 UT2X		
20	95701-08035-08	BOLT, FLANGE, 8X35	2	2	2	2	2	-----	EDE2, EDE2/A, EDS6, EDS6/A, LXE4, LXE8, QAE2, QAE2/A, QAE6, QAE6/A, QNB2, QNE2, QNE2/A, QNR2, QNR2/A, QNR6, QXE4, QXE4/A, QXE6, QXE8, SE2, SME0, SME0/A, SXE4, SXE4/A, SXE8, VWE, VWE/A, VWE2, VWE2/A, VXE2, VXE2/A, VXE7, VXE8, VXE8/A, VXE9
21	31219-ZE3-003	SCREW-WASHER, 4X14	2	2	2	2	2	-----	EDE2, EDE2/A, EDS6, EDS6/A, LXE4, LXE8, QAE2, QAE2/A, QAE6, QAE6/A, QNB2, QNE2, QNE2/A, QNR2, QNR2/A, QNR6, QXE4, QXE4/A, QXE6, QXE8, SE2, SME0, SME0/A, SXE4, SXE4/A, SXE8, VWE, VWE/A, VWE2, VWE2/A, VXE2, VXE2/A, VXE7, VXE8, VXE8/A, VXE9

E-21-1

STARTER MOTOR(2)

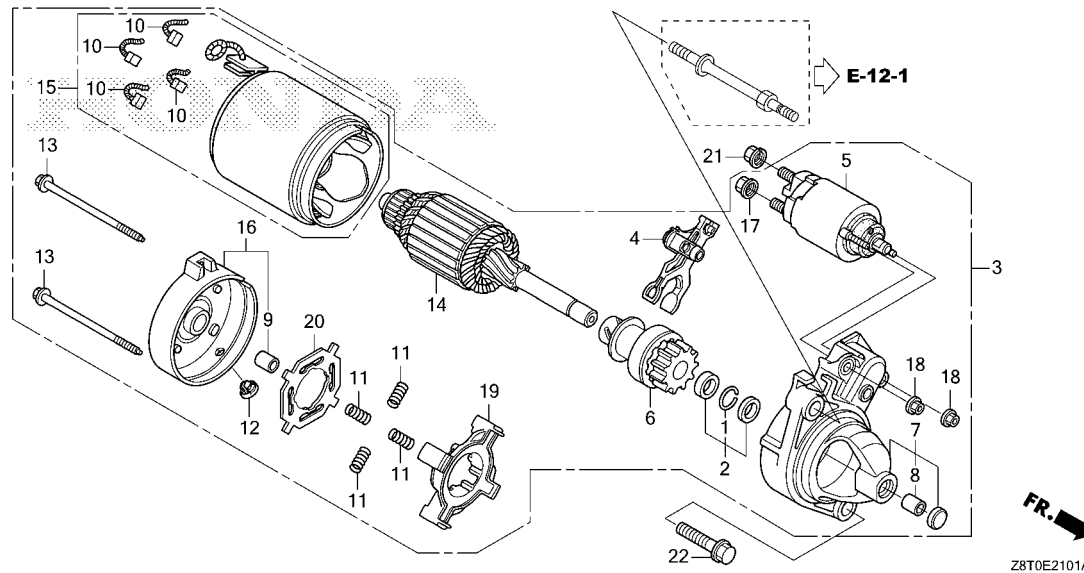

Ref. No. L.O.N. (Relative ref. Number) Description F.R.T.

Ref. No.	Part No.	Description	Reqd. QTY					Serial No.	Parts catalogue code
			GX 340 UT1	GX 340 UT2	GX 340 RT1	GX 340 RT2	GX 340 UT2X		
1	30201-PH9-004	RING, SNAP(DENSO).....	-	1	-	-	-	-----	QZA2, QZAV, QZN2, QZX4
2	30202-PZ1-003	COLLAR SET, CLUTCH STOP.....	-	1	-	-	-	-----	QZA2, QZAV, QZN2, QZX4
3	31200-Z5T-W01	MOTOR ASSY., STARTER.....	-	1	-	-	-	-----	QZA2, QZAV, QZN2, QZX4
4	31203-PH9-004	LEVER, PINION DRIVE.....	-	1	-	-	-	-----	QZA2, QZAV, QZN2, QZX4
5	31204-Z2E-003	SWITCH ASSY., MAGNET.....	-	1	-	-	-	-----	QZA2, QZAV, QZN2, QZX4
6	31207-ZE9-H01	CLUTCH COMP., OVERRUNNING....	-	1	-	-	-	-----	QZA2, QZAV, QZN2, QZX4
7	31208-Z5T-W00	HOUSING COMP., DRIVE SIDE....	-	1	-	-	-	-----	QZA2, QZAV, QZN2, QZX4
8	31209-PH9-004	BEARING A.....	-	1	-	-	-	-----	QZA2, QZAV, QZN2, QZX4
9	31210-PH9-004	BEARING B.....	-	1	-	-	-	-----	QZA2, QZAV, QZN2, QZX4
10	31211-PH9-004	BRUSH.....	-	4	-	-	-	-----	QZA2, QZAV, QZN2, QZX4
11	31212-PH9-004	SPRING, BRUSH.....	-	4	-	-	-	-----	QZA2, QZAV, QZN2, QZX4
12	31213-P64-N01	COVER.....	-	1	-	-	-	-----	QZA2, QZAV, QZN2, QZX4
13	31214-PH9-004	BOLT, THROUGH.....	-	2	-	-	-	-----	QZA2, QZAV, QZN2, QZX4
14	31217-Z0A-003	ARMATURE COMP.....	-	1	-	-	-	-----	QZA2, QZAV, QZN2, QZX4
15	31218-PH9-004	YOKE COMP.....	-	1	-	-	-	-----	QZA2, QZAV, QZN2, QZX4
16	31219-Z5T-W00	FRAME COMP., COMMUTATOR END..	-	1	-	-	-	-----	QZA2, QZAV, QZN2, QZX4
17	31220-PH9-004	NUT, HEX., 8MM.....	-	1	-	-	-	-----	QZA2, QZAV, QZN2, QZX4
18	31223-PA0-006	NUT, HEX.(6MM).....	-	2	-	-	-	-----	QZA2, QZAV, QZN2, QZX4
19	31231-PH9-004	HOLDER, BRUSH.....	-	1	-	-	-	-----	QZA2, QZAV, QZN2, QZX4
20	31233-PH9-004	INSULATOR, BRUSH HOLDER.....	-	1	-	-	-	-----	QZA2, QZAV, QZN2, QZX4
21	94070-08080	NUT-WASHER, 8MM.....	-	1	-	-	-	-----	QZA2, QZAV, QZN2, QZX4
22	95701-10040-00	BOLT, FLANGE, 10X40.....	-	1	-	-	-	-----	QZA2, QZAV, QZN2, QZX4



E-22

CONTROL

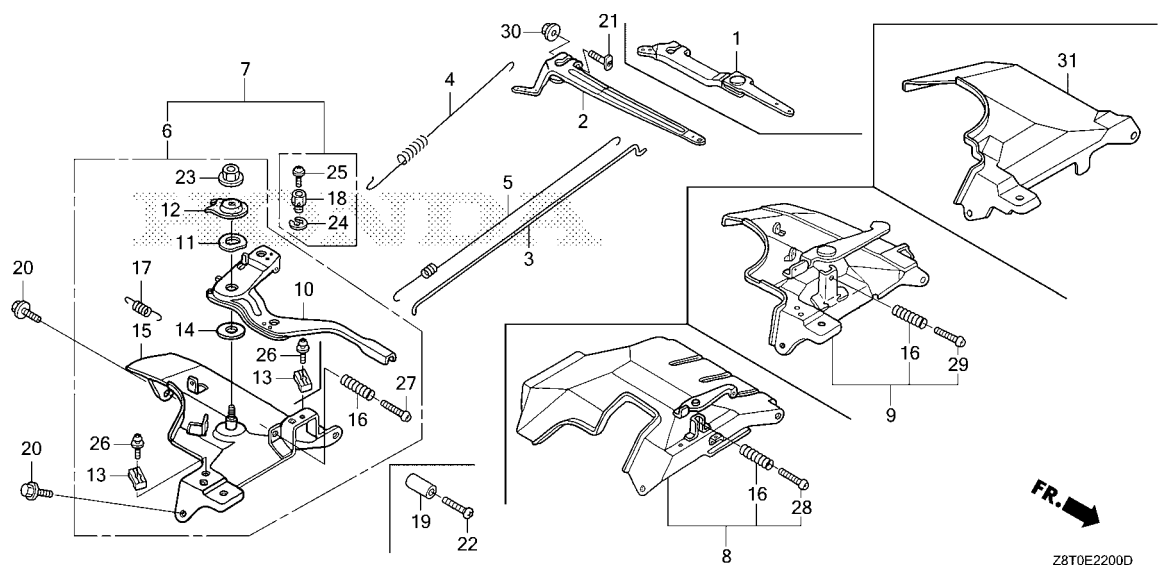

Ref. L.O.N. (Relative ref. Number) F.R.T.
No. Description

Ref. No.	Part No.	Description	Reqd. QTY					Serial No.	Parts catalogue code
			GX 340 UT1	GX 340 UT2	GX 340 RT1	GX 340 RT2	GX 340 UT2X		
1	16550-ZE3-700	ARM COMP., GOVERNOR	-	-	1	1	-	EDE2, EDE2/A, EDN2, EDN2/A, EDS6, EDS6/A, EDT6, EDT6/A, VC2, VWC VWC/A, VWE, VWE/A, VWS, VWS1, VWS1/A	
2	16551-ZE3-000	ARM, GOVERNOR	1	1	1	1	1	HA2, HA2/A, HX26, HX26/A, LX2, LXE4, LXE8, LXQ4, LXQ4/A, LXU, PKT2 PKT2/A, PKX2, PKX2/A, QA2, QA2/A, QA26, QAE2, QAE2/A, QAE6, QAE6/A, QAG QAH2, QAH2/A, QAP2, QAP2/A, QDW9, QE, QE/A, QHB4, QHB4/A, QHQ4 QKA4, QKA4/A, QMT2, QMT2/A, QNB2, QNE2, QNE2/A, QNR2, QNR2/A, QNR6 QWC, QWC/A, QXB7, QXB7/A, QXB9, QXC4, QXC6, QXC9, QXE4, QXE4/A QXE6, QXE8, QXQ4, QXQ4/A, QXU, QXU/A, SE, SE/A, SE1, SE2, SHQ4 SHQ4/A, SME0, SME0/A, SMX2, SXE4, SXE4/A, SXE8, SXQ4, SXQ4/A, VA2 VAD2, VDE2, VW12, VWE2, VWE2/A, VX16, VX16/A, VX8, VX8/A, VXB7 VXB9, VXE2, VXE2/A, VXE7, VXE8, VXE8/A, VXE9	
3	16555-ZE3-000	ROD, GOVERNOR	1	1	1	1	1	EDE2, EDE2/A, EDN2, EDN2/A, EDS6, EDS6/A, EDT6, EDT6/A, HA2, HA2/A HX26, HX26/A, LX2, LXE4, LXE8, LXQ4, LXQ4/A, LXU, PKT2, PKT2/A PKX2, PKX2/A, QA2, QA2/A, QA26, QAE2, QAE2/A, QAE6, QAE6/A, QAG QAH2, QAH2/A, QAP2, QAP2/A, QDW9, QE, QE/A, QHB4, QHB4/A, QHQ4 QMT2, QMT2/A, QNB2, QNE2, QNE2/A, QNR2, QNR2/A, QNR6, QWC, QWC/A QXB7, QXB7/A, QXB9, QXC6, QXC9, QXE4, QXE4/A, QXE6, QXE8, QXQ4 QXQ4/A, QXU, QXU/A, SE, SE/A, SE1, SE2, SHQ4, SHQ4/A, SME0, SME0/A SMX2, SXE4, SXE4/A, SXE8, SXQ4, SXQ4/A, VA2, VAD2, VC2, VDE2, VW12 VWC, VWC/A, VWE, VWE/A, VWE2, VWE2/A, VWS, VWS1, VWS1/A, VX16 VX16/A, VX8, VX8/A, VXB7, VXB9, VXE2, VXE2/A, VXE7, VXE8, VXE8/A VXE9	
	16555-ZE3-W00	ROD, GOVERNOR(STD.)	1	1	-	-	1	QKA4, QKA4/A, QXC4	

2

CONTROL

Ref. No.	Part No.	Description	Reqd. QTY					Serial No.	Parts catalogue code
			GX 340 UT1	GX 340 UT2	GX 340 RT1	GX 340 RT2	GX 340 UT2X		
4	16561-ZE3-000	SPRING, GOVERNOR(L=137.5MM) ..	1	1	1	-	1	-----	HA2, HA2/A, HX26, HX26/A, LX2, LXE4, LXE8, LXQ4, LXQ4/A, LXU, PKT2, PKT2/A, PKX2, PKX2/A, QA2, QA2/A, QA26, QAE2, QAE2/A, QAE6, QAE6/A, QAG, QAH2, QAH2/A, QAP2, QAP2/A, QDW9, QE, QE/A, QHB4, QHB4/A, QHQ4, QKA4, QKA4/A, QMT2, QMT2/A, QNB2, QNE2, QNE2/A, QNR2, QNR2/A, QNR6, QWC, QWC/A, QXB7, QXB7/A, QXB9, QXC4, QXC6, QXC9, QXE4, QXE4/A, QXE6, QXE8, QXQ4, QXQ4/A, QXU, QXU/A, SE, SE/A, SE1, SE2, SHQ4, SHQ4/A, SME0, SME0/A, SMX2, SXE4, SXE4/A, SXE8, SXQ4, SXQ4/A, VA2, VAD2, VDE2, VWE, VX16, VX16/A, VXB7, VXB9, VXE2, VXE2/A, VXE7, VXE9, VC2, VW12, VWC, VWE2, VX8, VX8/A, VXE8, VXE8/A
	16561-ZE3-710	SPRING, GOVERNOR(L=132.0MM) ..	1	1	1	-	1	-----	EDE2, EDE2/A, EDN2, EDN2/A, EDS6, EDS6/A, EDT6, EDT6/A, VWC, VWC/A, VWE, VWE/A, VWS, VWS1, VWS1/A
	16561-ZK6-D70	SPRING, GOVERNOR	-	-	-	-	1	-----	QNB2, VDE2
	16561-ZE3-000	SPRING, GOVERNOR(L=137.5MM) ..	-	-	-	-	1	-----	VWE2, VWE2/A
	16561-ZE3-710	SPRING, GOVERNOR(L=132.0MM) ..	-	-	-	-	1	-----	
5	16562-ZE3-000	SPRING, THROTTLE RETURN	1	1	1	1	1	-----	HA2, HA2/A, HX26, HX26/A, LX2, LXE4, LXE8, LXQ4, LXQ4/A, LXU, PKT2, PKT2/A, PKX2, PKX2/A, QA2, QA2/A, QA26, QAE2, QAE2/A, QAE6, QAE6/A, QAG, QAH2, QAH2/A, QAP2, QAP2/A, QDW9, QE, QE/A, QHB4, QHB4/A, QHQ4, QKA4, QKA4/A, QMT2, QMT2/A, QNB2, QNE2, QNE2/A, QNR2, QNR2/A, QNR6, QWC, QWC/A, QXB7, QXB7/A, QXB9, QXC4, QXC6, QXC9, QXE4, QXE4/A, QXE6, QXE8, QXQ4, QXQ4/A, QXU, QXU/A, SE, SE/A, SE1, SE2, SHQ4, SHQ4/A, SME0, SME0/A, SMX2, SXE4, SXE4/A, SXE8, SXQ4, SXQ4/A, VA2, VAD2, VDE2, VW12, VWE2, VWE2/A, VX16, VX16/A, VX8, VX8/A, VXB7, VXB9, VXE2, VXE2/A, VXE7, VXE8, VXE8/A, VXE9
	16562-ZE3-700	-	-	1	1	-	-----	EDE2, EDE2/A, EDN2, EDN2/A, EDS6, EDS6/A, EDT6, EDT6/A, VC2, VWC, VWC/A, VWE, VWE/A, VWS, VWS1, VWS1/A
6	16570-ZE3-W20	CONTROL ASSY. (REMOTE)	1	-	1	-	-	-----	HA2, HX26, LX2, LXE4, LXE8, LXQ4, LXU, QA2, QA26, QAE2, QAE6, QAG, QAH2, QE, QHQ4, QNB2, QNE2, QNR2, QNR6, QXB7, QXB9, QXC4, QXC6, QXC9, QXE4, QXE6, QXE8, QXQ4, QXU, SE, SHQ4, SME0, SXE4, SXE8, SXQ4, VA2
	16570-ZE3-W00	CONTROL ASSY. (STD.)	1	-	1	-	-	-----	PKT2, VDE2, VX16, VXE2
	16570-ZK3-870	CONTROL ASSY.	1	-	-	-	-	-----	VXB7, VXB9, VXE7, VXE9
	16500-Z5T-810	CONTROL ASSY. (REMOTE)(ROD) ..	-	1	-	1	1	-----	HA2, HA2/A, HX26, HX26/A, LX2, LXE4, LXQ4, LXQ4/A, LXU, QA2, QA2/A, QAE2, QAE2/A, QAE6, QAE6/A, QAG, QAH2, QAH2/A, QE, QE/A, QHQ4, QNB2, QNE2, QNE2/A, QNR2, QNR2/A, QWC, QWC/A, QXB7, QXB7/A, QXB9, QXC9, QXE4, QXE4/A, QXE6, QXE8, QXQ4, QXQ4/A, QXU, QXU/A, SE, SE/A, SE2, SHQ4, SHQ4/A, SME0, SME0/A, SXE4, SXE4/A, SXE8, SXQ4, SXQ4/A, VA2
	16500-Z5T-307	CONTROL ASSY. (REMOTE) (FOR U.S.A.)	-	1	-	1	-	-----	HA2, HX26, LX2, LXE4, LXQ4, LXU, QA2, QAE2, QAE6, QAG, QAH2, QE, QHQ4, QNB2, QNE2, QNR2, QXB7, QXB9, QXC9, QXE4, QXE6, QXE8, QXQ4, QXU, SE, SHQ4, SME0, SXE4, SXE8, SXQ4, VA2
	16500-Z5T-000	CONTROL ASSY. (STD.)	-	1	-	1	-	-----	VDE2, VX16, VX16/A, VXE2, VXE2/A
	16500-Z5T-305	CONTROL ASSY. (FOR U.S.A.)	-	1	-	1	-	-----	VDE2, VX16, VXE2
	16500-Z5T-920	CONTROL ASSY.	-	1	-	-	-	-----	PKT2, PKT2/A, PKX2/A
	16500-Z5T-405	CONTROL ASSY. (REMOTE)(COO) (FOR U.S.A.)	-	1	-	-	-	-----	PKT2, PKX2
	16500-Z5T-407	CONTROL ASSY. (FOR U.S.A.)	-	1	-	-	-	-----	QMT2
	16500-Z5T-309	CONTROL ASSY. (COO)(FOR U.S.A.)	-	1	-	-	-	-----	VXB7, VXB9, VXE9
	16500-Z5T-850	CONTROL ASSY.	-	1	-	-	-	-----	VXB7, VXB9, VXE9
	16570-ZE3-W30	-	-	1	-	-	-----	VAD2
	16500-Z5T-920	-	-	-	1	-	-----	PKT2, PKX2
7	16570-ZE3-W10	CONTROL ASSY. (REMOTE)	1	-	-	-	-	-----	QAP2, QDW9, QHB4, QKA4
	16500-Z5T-800	-	1	-	-	1	-----	QAP2, QAP2/A, QDW9, QHB4, QHB4/A, QKA4, QKA4/A
	16500-Z5T-830	CONTROL ASSY. (REMOTE) (WITH PLUG)	-	1	-	-	1	-----	SE1
	16500-Z5T-306	CONTROL ASSY. (REMOTE) (FOR U.S.A.)	-	1	-	-	-	-----	QAP2, QDW9, QHB4, QKA4, SMX2
8	16570-ZE3-700	CONTROL ASSY.	-	-	1	-	-	-----	VWC, VWE
	16500-Z5T-880	-	-	-	1	-	-----	EDE2, EDE2/A, EDN2, EDN2/A, EDS6, EDS6/A, EDT6, EDT6/A, VWC, VWC/A, VWE, VWE/A, VWS, VWS1, VWS1/A



E-22

CONTROL

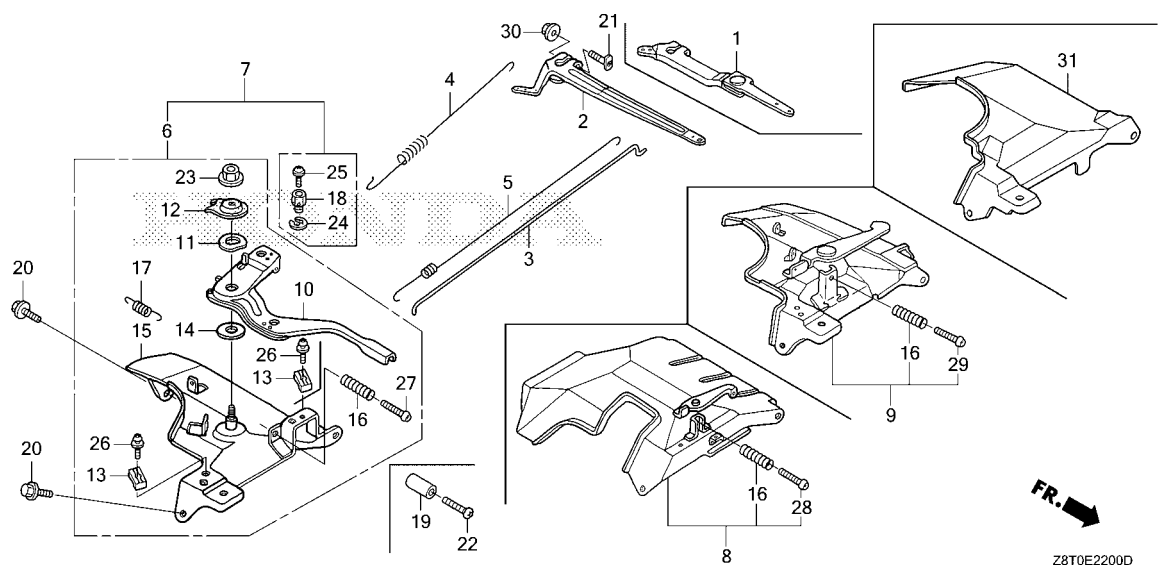

Ref. No.	Part No.	Description	Reqd. QTY					Serial No.	Parts catalogue code
			GX 340 UT1	GX 340 UT2	GX 340 RT1	GX 340 RT2	GX 340 UT2X		
(8)	16500-Z5T-408	CONTROL ASSY. (COO)(FOR U.S.A.)	-	-	-	1	-	EDE2, EDN2, EDS6, EDT6, VWC, VWE, VWS	
9	16570-ZE3-721	CONTROL ASSY.	1	-	1	-	-	VW12, VWE2, VX8, VXE8	
	16500-Z5T-870	-	1	-	1	1	VWE2, VWE2/A, VX8, VX8/A, VXE8, VXE8/A	
	16501-Z5T-307	CONTROL ASSY. (FOR U.S.A.)	-	1	-	1	-	VWE2, VX8, VXE8	
	16570-ZK3-S60	CONTROL ASSY.	-	-	1	-	-	VC2	
10	16571-ZE3-W00	LEVER, CONTROL	1	1	1	1	1	HA2, HA2/A, HX26, HX26/A, LX2, LXE4, LXE8, LXQ4, LXQ4/A, LXU, PKT2, PKT2/A, PKX2, PKX2/A, QA2, QA2/A, QA26, QAE2, QAE2/A, QAE6, QAE6/A, QAG, QAH2, QAH2/A, QAP2, QAP2/A, QDW9, QE, QE/A, QHB4, QHB4/A, QHQ4, QKA4, QKA4/A, QMT2, QMT2/A, QNB2, QNE2, QNE2/A, QNR2, QNR2/A, QNR6, QWC, QWC/A, QXB7, QXB7/A, QXB9, QXC4, QXC6, QXC9, QXE4, QXE4/A, QXE6, QXE8, QXQ4, QXQ4/A, QXU, QXU/A, SE, SE/A, SE1, SE2, SHQ4, SHQ4/A, SME0, SME0/A, SMX2, SXE4, SXE4/A, SXE8, SXQ4, SXQ4/A, VA2, VDE2, VX16, VX16/A, VXB7, VXB9, VXE2, VXE2/A, VXE7, VXE9, VAD2	
	16571-ZE3-W10	-	-	1	-	-	VAD2	
11	16574-ZE1-000	SPRING, LEVER	1	1	1	1	1	HA2, HA2/A, HX26, HX26/A, LX2, LXE4, LXE8, LXQ4, LXQ4/A, LXU, PKT2, PKT2/A, PKX2, PKX2/A, QA2, QA2/A, QA26, QAE2, QAE2/A, QAE6, QAE6/A, QAG, QAH2, QAH2/A, QAP2, QAP2/A, QDW9, QE, QE/A, QHB4, QHB4/A, QHQ4, QKA4, QKA4/A, QMT2, QMT2/A, QNB2, QNE2, QNE2/A, QNR2, QNR2/A, QNR6, QWC, QWC/A, QXB7, QXB7/A, QXB9, QXC4, QXC6, QXC9, QXE4, QXE4/A, QXE6, QXE8, QXQ4, QXQ4/A, QXU, QXU/A, SE, SE/A, SE1, SE2, SHQ4, SHQ4/A, SME0, SME0/A, SMX2, SXE4, SXE4/A, SXE8, SXQ4, SXQ4/A, VA2, VAD2, VDE2, VX16, VX16/A, VXB7, VXB9, VXE2, VXE2/A, VXE7, VXE9	

E-22

CONTROL

Ref. No.	Part No.	Description	Reqd. QTY					Serial No.	Parts catalogue code
			GX 340 UT1	GX 340 UT2	GX 340 RT1	GX 340 RT2	GX 340 UT2X		
12	16575-ZE2-W00	WASHER, CONTROL LEVER	1	1	1	1	1	-----	HA2, HA2/A, HX26, HX26/A, LX2, LXE4, LXE8, LXQ4, LXQ4/A, LXU, PKT2, PKT2/A, PKX2, PKX2/A, QA2, QA2/A, QA26, QAE2, QAE2/A, QAE6, QAE6/A, QAG, QAH2, QAH2/A, QAP2, QAP2/A, QDW9, QE, QE/A, QHB4, QHB4/A, QHQ4, QKA4, QKA4/A, QMT2, QMT2/A, QNB2, QNE2, QNE2/A, QNR2, QNR2/A, QNR6, QWC, QWC/A, QXB7, QXB7/A, QXB9, QXC4, QXC6, QXC9, QXE4, QXE4/A, QXE6, QXE8, QXQ4, QXQ4/A, QXU, QXU/A, SE, SE/A, SE1, SE2, SHQ4, SHQ4/A, SME0, SME0/A, SMX2, SXE4, SXE4/A, SXE8, SXQ4, SXQ4/A, VA2, VAD2, VDE2, VX16, VX16/A, VXB7, VXB9, VXE2, VXE2/A, VXE7, VXE9
13	16576-891-000	HOLDER, CABLE	1	1	1	1	1	-----	HA2, HA2/A, HX26, HX26/A, LX2, LXE4, LXE8, LXQ4, LXQ4/A, LXU, QA2, QA2/A, QA26, QAE2, QAE2/A, QAE6, QAE6/A, QAG, QAH2, QAH2/A, QAP2, QAP2/A, QDW9, QE, QE/A, QHB4, QHB4/A, QHQ4, QKA4, QKA4/A, QMT2, QMT2/A, QNB2, QNE2, QNE2/A, QNR2, QNR2/A, QNR6, QWC, QWC/A, QXB7, QXB7/A, QXB9, QXC4, QXC6, QXC9, QXE4, QXE4/A, QXE6, QXE8, QXQ4, QXQ4/A, QXU, QXU/A, SE, SE/A, SE1, SE2, SHQ4, SHQ4/A, SME0, SME0/A, SMX2, SXE4, SXE4/A, SXE8, SXQ4, SXQ4/A, VA2
14	16578-ZE1-000	SPACER, CONTROL LEVER	1	1	1	1	1	-----	HA2, HA2/A, HX26, HX26/A, LX2, LXE4, LXE8, LXQ4, LXQ4/A, LXU, PKT2, PKT2/A, PKX2, PKX2/A, QA2, QA2/A, QA26, QAE2, QAE2/A, QAE6, QAE6/A, QAG, QAH2, QAH2/A, QAP2, QAP2/A, QDW9, QE, QE/A, QHB4, QHB4/A, QHQ4, QKA4, QKA4/A, QMT2, QMT2/A, QNB2, QNE2, QNE2/A, QNR2, QNR2/A, QNR6, QWC, QWC/A, QXB7, QXB7/A, QXB9, QXC4, QXC6, QXC9, QXE4, QXE4/A, QXE6, QXE8, QXQ4, QXQ4/A, QXU, QXU/A, SE, SE/A, SE1, SE2, SHQ4, SHQ4/A, SME0, SME0/A, SMX2, SXE4, SXE4/A, SXE8, SXQ4, SXQ4/A, VA2
15	16581-ZE3-W00	BASE COMP., CONTROL(###)	1	-	1	-	-	-----	HA2, HX26, LX2, LXE4, LXE8, LXQ4, LXU, PKT2, QA2, QA26, QAE2, QAE6, QAG, QAH2, QAP2, QDW9, QE, QHB4, QHQ4, QKA4, QNB2, QNE2, QNR2, QNR6, QXB7, QXB9, QXC4, QXC6, QXC9, QXE4, QXE6, QXE8, QXQ4, QXU, SE, SHQ4, SME0, SXE4, SXE8, SXQ4, VA2, VAD2, VDE2, VX16, VXE2
	16580-Z5T-000	BASE COMP., CONTROL	-	1	-	1	1	-----	HA2, HA2/A, HX26, HX26/A, LX2, LXE4, LXQ4, LXQ4/A, LXU, QA2, QA2/A, QAE2, QAE2/A, QAE6, QAE6/A, QAG, QAH2, QAH2/A, QAP2, QAP2/A, QDW9, QE, QE/A, QHB4, QHB4/A, QHQ4, QKA4, QKA4/A, QNB2, QNE2, QNE2/A, QNR2, QNR2/A, QNR6, QWC, QWC/A, QXB7, QXB7/A, QXB9, QXC4, QXC6, QXC9, QXE4, QXE4/A, QXE6, QXE8, QXQ4, QXQ4/A, QXU, QXU/A, SE, SE/A, SE1, SE2, SHQ4, SHQ4/A, SME0, SME0/A, SMX2, SXE4, SXE4/A, SXE8, SXQ4, SXQ4/A, VA2, VDE2, VX16, VX16/A, VXE2, VXE2/A
	16580-Z5T-920	-	1	-	-	1	-----	PKT2, PKT2/A, PKX2, PKX2/A, QMT2, QMT2/A
	16580-Z5T-850	-	1	-	-	-	-----	VXB7, VXB9, VXE9
16	16584-883-300	SPRING, CONTROL ADJUSTING	1	1	1	1	1	-----	EDE2, EDE2/A, EDN2, EDN2/A, EDS6, EDS6/A, EDT6, EDT6/A, HA2, HA2/A, HX26, HX26/A, LX2, LXE4, LXE8, LXQ4, LXQ4/A, LXU, PKT2, PKT2/A, PKX2, PKX2/A, QA2, QA2/A, QA26, QAE2, QAE2/A, QAE6, QAE6/A, QAG, QAH2, QAH2/A, QAP2, QAP2/A, QDW9, QE, QE/A, QHB4, QHB4/A, QHQ4, QKA4, QKA4/A, QMT2, QMT2/A, QNB2, QNE2, QNE2/A, QNR2, QNR2/A, QNR6, QWC, QWC/A, QXB7, QXB7/A, QXB9, QXC4, QXC6, QXC9, QXE4, QXE4/A, QXE6, QXE8, QXQ4, QXQ4/A, QXU, QXU/A, SE, SE/A, SE1, SE2, SHQ4, SHQ4/A, SME0, SME0/A, SMX2, SXE4, SXE4/A, SXE8, SXQ4, SXQ4/A, VA2, VAD2, VC2, VDE2, VW12, VWC, VWC/A, VWE, VWE/A, VWE2, VWE2/A, VWS, VWS1, VWS1/A, VX16, VX16/A, VX8, VX8/A, VXB7, VXB9, VXE2, VXE2/A, VXE7, VXE8, VXE8/A, VXE9
17	16592-883-310	SPRING, CABLE RETURN	1	1	1	1	1	-----	HA2, HA2/A, HX26, HX26/A, LX2, LXE4, LXE8, LXQ4, LXQ4/A, LXU, QA2, QA2/A, QA26, QAE2, QAE2/A, QAE6, QAE6/A, QAG, QAH2, QAH2/A, QAP2, QAP2/A, QDW9, QE, QE/A, QHB4, QHB4/A, QHQ4, QKA4, QKA4/A, QMT2, QMT2/A, QNB2, QNE2, QNE2/A, QNR2, QNR2/A, QNR6, QWC, QWC/A, QXB7, QXB7/A, QXB9, QXC4, QXC6, QXC9, QXE4, QXE4/A, QXE6, QXE8, QXQ4, QXQ4/A, QXU, QXU/A, SE, SE/A, SE1, SE2, SHQ4, SHQ4/A, SME0, SME0/A, SMX2, SXE4, SXE4/A, SXE8, SXQ4, SXQ4/A, VA2
18	16594-883-010	HOLDER, WIRE	1	1	-	-	1	-----	QAP2, QAP2/A, QDW9, QHB4, QHB4/A, QKA4, QKA4/A, SE1, SMX2



E-22

CONTROL

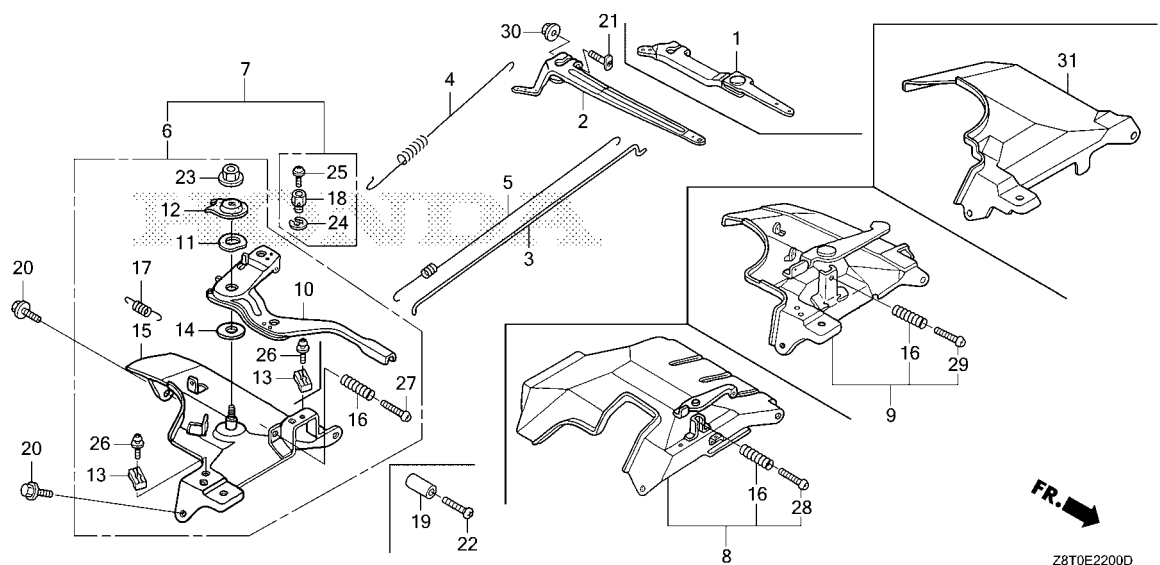

Ref. No.	Part No.	Description	Reqd. QTY					Serial No.	Parts catalogue code
			GX 340 UT1	GX 340 UT2	GX 340 RT1	GX 340 RT2	GX 340 UT2X		
19	16599-ZG1-M10	COLLAR, STOPPER.....	(1)	-	-	-	-	-----	LXE4, LXQ4, QE, QHB4, QHQ4, QKA4, QXB7, QXB9, QXC4, QXE4, QXQ4, SE SHQ4, SME0, SXE4, SXQ4, VXB7, VXB9, VXE7, VXE9 LXE4, LXQ4, LXQ4/A, QE, QE/A, QHB4, QHB4/A, QHQ4, QKA4, QKA4/A QXB7, QXB7/A, QXB9, QXE4, QXE4/A, QXQ4, QXQ4/A, SE, SE/A, SE1, SE2 SHQ4, SHQ4/A, SME0, SME0/A, SXE4, SXE4/A, SXQ4, SXQ4/A, VXB7, VXB9 VXE9
20	90013-883-000	BOLT, FLANGE, 6X12(CT200)....	2	2	2	2	2	-----	EDE2, EDE2/A, EDN2, EDN2/A, EDS6, EDS6/A, EDT6, EDT6/A, HA2, HA2/A HX26, HX26/A, LX2, LXE4, LXE8, LXQ4, LXQ4/A, LXU, PKT2, PKT2/A PKX2, PKX2/A, QA2, QA2/A, QA26, QAE2, QAE2/A, QAE6, QAE6/A, QAG QAH2, QAH2/A, QAP2, QAP2/A, QDW9, QE, QE/A, QHB4, QHB4/A, QHQ4 QKA4, QKA4/A, QMT2, QMT2/A, QNB2, QNE2, QNE2/A, QNR2, QNR2/A, QNR6 QWC, QWC/A, QXB7, QXB7/A, QXB9, QXC4, QXC6, QXC9, QXE4, QXE4/A QXE6, QXE8, QXQ4, QXQ4/A, QXU, QXU/A, SE, SE/A, SE1, SE2, SHQ4 SHQ4/A, SME0, SME0/A, SMX2, SXE4, SXE4/A, SXE8, SXQ4, SXQ4/A, VA2 VAD2, VC2, VDE2, VW12, VWC, VWC/A, VWE, VWE/A, VWE2, VWE2/A, VWS VWS1, VWS1/A, VX16, VX16/A, VX8, VX8/A, VXB7, VXB9, VXE2, VXE2/A VXE7, VXE8, VXE8/A, VXE9
21	90015-ZE5-010 90015-Z5T-000	BOLT, GOVERNOR ARM.....	1	-	1	-	-	-----	EDE2, EDE2/A, EDN2, EDN2/A, EDS6, EDS6/A, EDT6, EDT6/A, HA2, HA2/A HX26, HX26/A, LX2, LXE4, LXQ4, LXQ4/A, LXU, PKT2, PKT2/A, PKX2 PKX2/A, QA2, QA2/A, QAE2, QAE2/A, QAE6, QAE6/A, QAG, QAH2, QAH2/A QAP2, QAP2/A, QDW9, QE, QE/A, QHB4, QHB4/A, QHQ4, QKA4, QKA4/A QMT2, QMT2/A, QNB2, QNE2, QNE2/A, QNR2, QNR2/A, QWC, QWC/A, QXB7 QXB7/A, QXB9, QXC9, QXE4, QXE4/A, QXE6, QXE8, QXQ4, QXQ4/A, QXU QXU/A, SE, SE/A, SE1, SE2, SHQ4, SHQ4/A, SME0, SME0/A, SMX2, SXE4 SXE4/A, SXE8, SXQ4, SXQ4/A, VA2, VDE2, VWC, VWC/A, VWE, VWE/A, VWE2 VWE2/A, VWS, VWS1, VWS1/A, VX16, VX16/A, VX8, VX8/A, VXB7, VXB9 VXE2, VXE2/A, VXE8, VXE8/A, VXE9

E-22

CONTROL

Ref. No.	Part No.	Description	Reqd. QTY					Serial No.	Parts catalogue code
			GX 340 UT1	GX 340 UT2	GX 340 RT1	GX 340 RT2	GX 340 UT2X		
22	90016-ZG9-N30	SCREW, RECESSED, 5X25	(1)	-	-	-	-	-----	LXE4, LXQ4, QE, QHB4, QHQ4, QKA4, QXB7, QXB9, QXC4, QXE4, QXQ4, SE SHQ4, SME0, SXE4, SXQ4, VXB7, VXB9, VXE7, VXE9
			-	1	-	-	1	-----	LXE4, LXQ4, LXQ4/A, QE, QE/A, QHB4, QHB4/A, QHQ4, QKA4, QKA4/A QXB7, QXB7/A, QXB9, QXE4, QXE4/A, QXQ4, QXQ4/A, SE, SE/A, SE1, SE2 SHQ4, SHQ4/A, SME0, SME0/A, SXE4, SXE4/A, SXQ4, SXQ4/A, VXB7, VXB9 VXE9
23	90114-SA0-000	NUT, SELF-LOCK, 6MM	1	1	1	1	1	-----	HA2, HA2/A, HX26, HX26/A, LX2, LXE4, LXE8, LXQ4, LXQ4/A, LXU, PKT2 PKT2/A, PKX2, PKX2/A, QA2, QA2/A, QA26, QAE2, QAE2/A, QAE6, QAE6/A QAG, QAH2, QAH2/A, QAP2, QAP2/A, QDW9, QE, QE/A, QHB4, QHB4/A, QHQ4 QKA4, QKA4/A, QMT2, QMT2/A, QNB2, QNE2, QNE2/A, QNR2, QNR2/A, QNR6 QWC, QWC/A, QXB7, QXB7/A, QXB9, QXC4, QXC6, QXC9, QXE4, QXE4/A QXE6, QXE8, QXQ4, QXQ4/A, QXU, QXU/A, SE, SE/A, SE1, SE2, SHQ4 SHQ4/A, SME0, SME0/A, SMX2, SXE4, SXE4/A, SXE8, SXQ4, SXQ4/A, VA2 VAD2, VDE2, VX16, VX16/A, VXB7, VXB9, VXE2, VXE2/A, VXE7, VXE9
	90202-Z1T-000	1	-	1	-	-	-----	HA2, HX26, LX2, LXE4, LXE8, LXQ4, LXU, QA2, QA26, QAE2, QAE6, QAG QAH2, QAP2, QDW9, QE, QHB4, QHQ4, QKA4, QNB2, QNE2, QNR2, QNR6, QXB7 QXB9, QXC4, QXC6, QXC9, QXE4, QXE6, QXE8, QXQ4, QXU, SE, SHQ4, SME0 SXE4, SXE8, SXQ4, VA2
24	90605-230-000	CIRCLIP, 5MM	1	1	-	-	1	-----	QAP2, QAP2/A, QDW9, QHB4, QHB4/A, QKA4, QKA4/A, SE1, SMX2
25	93500-04006-0H	SCREW, PAN, 4X6	1	1	-	-	1	-----	QAP2, QAP2/A, QDW9, QHB4, QHB4/A, QKA4, QKA4/A, SE1, SMX2
26	93500-05016-0A	SCREW, PAN, 5X16	1	1	1	1	1	-----	HA2, HA2/A, HX26, HX26/A, LX2, LXE4, LXE8, LXQ4, LXQ4/A, LXU, QA2 QA2/A, QA26, QAE2, QAE2/A, QAE6, QAE6/A, QAG, QAH2, QAH2/A, QAP2 QAP2/A, QDW9, QE, QE/A, QHB4, QHB4/A, QHQ4, QKA4, QKA4/A, QMT2 QMT2/A, QNB2, QNE2, QNE2/A, QNR2, QNR2/A, QNR6, QWC, QWC/A, QXB7 QXB7/A, QXB9, QXC4, QXC6, QXC9, QXE4, QXE4/A, QXE6, QXE8, QXQ4 QXQ4/A, QXU, QXU/A, SE, SE/A, SE1, SE2, SHQ4, SHQ4/A, SME0, SME0/A SMX2, SXE4, SXE4/A, SXE8, SXQ4, SXQ4/A, VA2
27	93500-05032-0A	SCREW, PAN, 5X32	1	1	1	1	1	-----	HA2, HA2/A, HX26, HX26/A, LX2, LXE4, LXE8, LXQ4, LXQ4/A, LXU, PKT2 PKT2/A, PKX2, PKX2/A, QA2, QA2/A, QA26, QAE2, QAE2/A, QAE6, QAE6/A QAG, QAH2, QAH2/A, QAP2, QAP2/A, QDW9, QE, QE/A, QHB4, QHB4/A, QHQ4 QKA4, QKA4/A, QMT2, QMT2/A, QNB2, QNE2, QNE2/A, QNR2, QNR2/A, QNR6 QWC, QWC/A, QXB7, QXB7/A, QXB9, QXC4, QXC6, QXC9, QXE4, QXE4/A QXE6, QXE8, QXQ4, QXQ4/A, QXU, QXU/A, SE, SE/A, SE1, SE2, SHQ4, SHQ4/A, SME0, SME0/A, SMX2, SXE4, SXE4/A, SXE8, SXQ4, SXQ4/A, VA2 VAD2, VDE2, VX16, VX16/A, VXB7, VXB9, VXE2, VXE2/A, VXE7, VXE9
28	93500-05035-0A	SCREW, PAN, 5X35	-	-	1	1	-	-----	EDE2, EDE2/A, EDN2, EDN2/A, EDS6, EDS6/A, EDT6, EDT6/A, VWC, VWC/A VWE, VWE/A, VWS, VWS1, VWS1/A
29	93500-05045-0A	SCREW, PAN, 5X45	1	1	1	1	1	-----	VC2, VW12, VWE2, VWE2/A, VX8, VX8/A, VXE8, VXE8/A
30	94050-06000	NUT, FLANGE, 6MM	1	1	1	1	1	-----	EDE2, EDE2/A, EDN2, EDN2/A, EDS6, EDS6/A, EDT6, EDT6/A, HA2, HA2/A HX26, HX26/A, LX2, LXE4, LXE8, LXQ4, LXQ4/A, LXU, PKT2, PKT2/A PKX2, PKX2/A, QA2, QA2/A, QA26, QAE2, QAE2/A, QAE6, QAE6/A, QAG QAH2, QAH2/A, QAP2, QAP2/A, QDW9, QE, QE/A, QHB4, QHB4/A, QHQ4 QKA4, QKA4/A, QMT2, QMT2/A, QNB2, QNE2, QNE2/A, QNR2, QNR2/A, QNR6 QWC, QWC/A, QXB7, QXB7/A, QXB9, QXC4, QXC6, QXC9, QXE4, QXE4/A QXE6, QXE8, QXQ4, QXQ4/A, QXU, QXU/A, SE, SE/A, SE1, SE2, SHQ4 SHQ4/A, SME0, SME0/A, SMX2, SXE4, SXE4/A, SXE8, SXQ4, SXQ4/A, VA2 VAD2, VC2, VDE2, VW12, VWC, VWC/A, VWE, VWE/A, VWE2, VWE2/A, VWS VWS1, VWS1/A, VX16, VX16/A, VX8, VX8/A, VXB7, VXB9, VXE2, VXE2/A VXE7, VXE8, VXE8/A, VXE9
31	19630-Z5T-W00	SHROUD COMP., UPPER	-	1	-	-	-	-----	QZA2, QZAV, QZN2, QZX4



E-22-20

AUTO THROTTLE

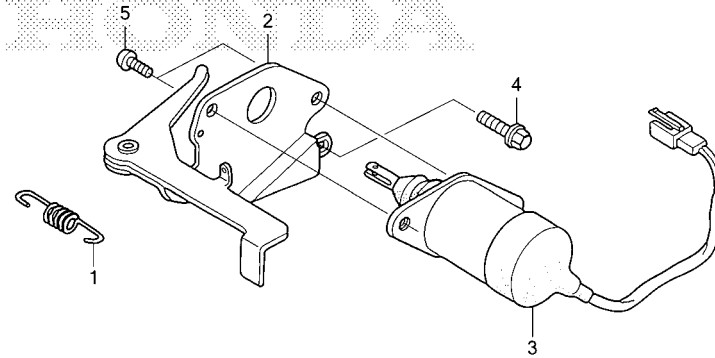

Z8T0E2220A

Ref. L.O.N. (Relative ref. Number) F.R.T.
No. Description

Ref. No.	Part No.	Description	Reqd. QTY					Serial No.	Parts catalogue code
			GX 340 UT1	GX 340 UT2	GX 340 RT1	GX 340 RT2	GX 340 UT2X		
1	16268-893-000	SPRING, CHOKE RETURN.....	-	-	1	1	-	EDE2, EDE2/A, EDN2, EDN2/A, EDS6, EDS6/A, EDT6, EDT6/A, VC2, VWC VWC/A, VWE, VWE/A, VWS, VWS1, VWS1/A	
2	17850-ZD1-E30	LEVER COMP., THROTTLE.....	-	-	1	1	-	EDE2, EDE2/A, EDN2, EDN2/A, EDS6, EDS6/A, EDT6, EDT6/A, VC2, VWC VWC/A, VWE, VWE/A, VWS, VWS1, VWS1/A	
3	36160-ZB4-013	SOLENOID ASSY.....	-	-	1	1	-	EDE2, EDE2/A, EDN2, EDN2/A, EDS6, EDS6/A, EDT6, EDT6/A, VC2, VWC VWC/A, VWE, VWE/A, VWS, VWS1, VWS1/A	
4	90013-883-000	BOLT, FLANGE, 6X12(CT200)....	-	-	1	1	-	EDE2, EDE2/A, EDN2, EDN2/A, EDS6, EDS6/A, EDT6, EDT6/A, VC2, VWC VWC/A, VWE, VWE/A, VWS, VWS1, VWS1/A	
5	93500-05008-0A	SCREW, PAN, 5X8.....	-	-	2	2	-	EDE2, EDE2/A, EDN2, EDN2/A, EDS6, EDS6/A, EDT6, EDT6/A, VC2, VWC VWC/A, VWE, VWE/A, VWS, VWS1, VWS1/A	

E-23

CONTROL BOX(1)

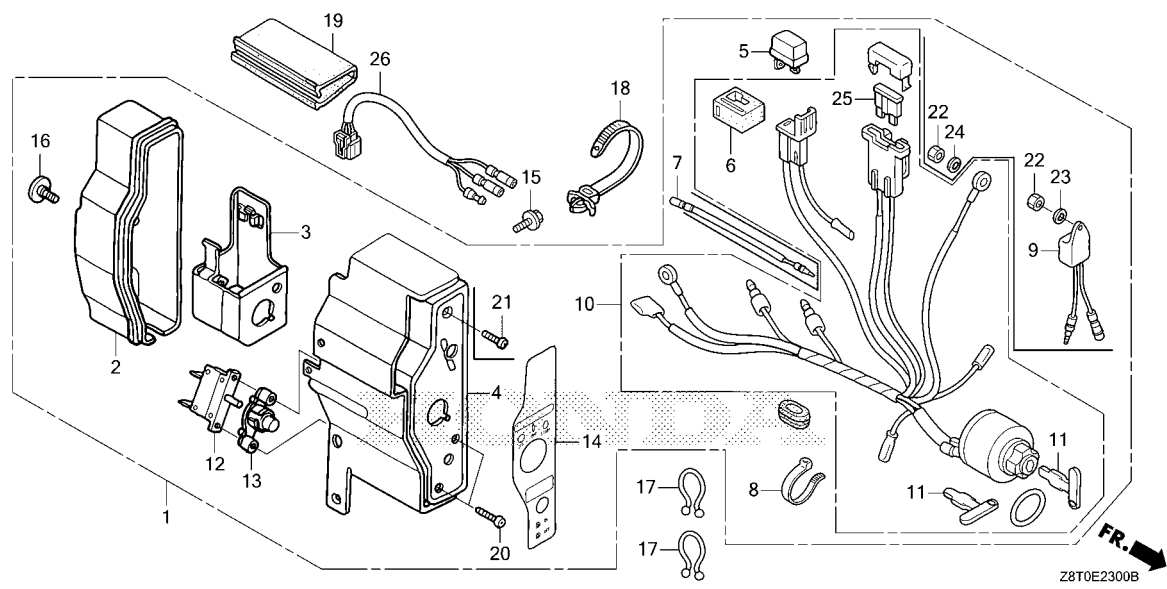

Ref. L.O.N. (Relative ref. Number) F.R.T.
 No. Description

Ref. No.	Part No.	Description	Reqd. QTY					Serial No.	Parts catalogue code
			GX 340 UT1	GX 340 UT2	GX 340 RT1	GX 340 RT2	GX 340 UT2X		
1	31610-Z5T-802ZC	BOX ASSY., CONTROL(EXP-ALERT) *NH105*....MAT BLACK(#15-#20)	1	-	1	-	-	-----	VWE2, VXE2, VXE7, VXE9
	31610-Z5T-802ZA	*R280*.....POWER RED	1	-	-	-	-	-----	LXE4, LXE8, QXE4, QXE6, QXE8, SXE4, SXE8, VXE2, VXE7, VXE8, VXE9
	31610-Z5S-802ZA	BOX ASSY., CONTROL(EXP-ALERT) (3A)						-----	
		NH1.....BLACK	1	-	-	-	-	-----	QAE2
	31610-Z5S-802ZB	*R280*.....POWER RED	1	-	-	-	-	-----	QAE2, QAE6
	31610-Z5T-811ZA	BOX ASSY., CONTROL(EXTERNAL)						-----	
		NH1.....BLACK	-	1	-	1	-	-----	VWE2, VWE2/A, VXE2, VXE2/A, VXE9
	31610-Z5T-811ZB	*R280*.....POWER RED	-	1	-	-	1	-----	LXE4, QXE4, QXE4/A, QXE6, QXE8, SXE4, SXE4/A, SXE8, VXE2, VXE2/A, VXE8, VXE8/A, VXE9
	31610-Z5T-821ZA	BOX ASSY., CONTROL(3A)						-----	
		NH1.....BLACK	-	1	-	-	1	-----	QAE2, QAE2/A
	31610-Z5T-821ZB	*R280*.....POWER RED	-	1	-	-	1	-----	QAE2, QAE2/A, QAE6, QAE6/A
2	31612-ZE2-003	CASE, CONTROL.....	1	1	1	1	1	-----	LXE4, LXE8, QAE2, QAE2/A, QAE6, QAE6/A, QXE4, QXE4/A, QXE6, QXE8, SXE4, SXE4/A, SXE8, VWE2, VWE2/A, VXE2, VXE2/A, VXE7, VXE8, VXE8/A, VXE9
3	31614-ZE2-003	BRACKET, CASE MOUNTING.....	1	1	1	1	1	-----	LXE4, LXE8, QAE2, QAE2/A, QAE6, QAE6/A, QXE4, QXE4/A, QXE6, QXE8, SXE4, SXE4/A, SXE8, VWE2, VWE2/A, VXE2, VXE2/A, VXE7, VXE8, VXE8/A, VXE9
4	31615-ZE3-003ZE	PANEL COMP., CONTROL						-----	
		R280.....POWER RED	1	1	-	-	1	-----	LXE4, LXE8, QAE2, QAE2/A, QAE6, QAE6/A, QXE4, QXE4/A, QXE6, QXE8, SXE4, SXE4/A, SXE8, VXE2, VXE2/A, VXE7, VXE8, VXE8/A, VXE9
	31615-ZE3-003ZD	*NH105*....MAT BLACK(#15-#20)	1	-	1	-	-	-----	VWE2, VXE2, VXE7, VXE9
	31615-ZE3-003ZA	*NH1*.....BLACK	1	-	-	1	1	-----	QAE2, VWE2, VWE2/A
			-	1	-	-	-	-----	QAE2, QAE2/A, VXE2, VXE2/A, VXE9



E-23

CONTROL BOX(1)

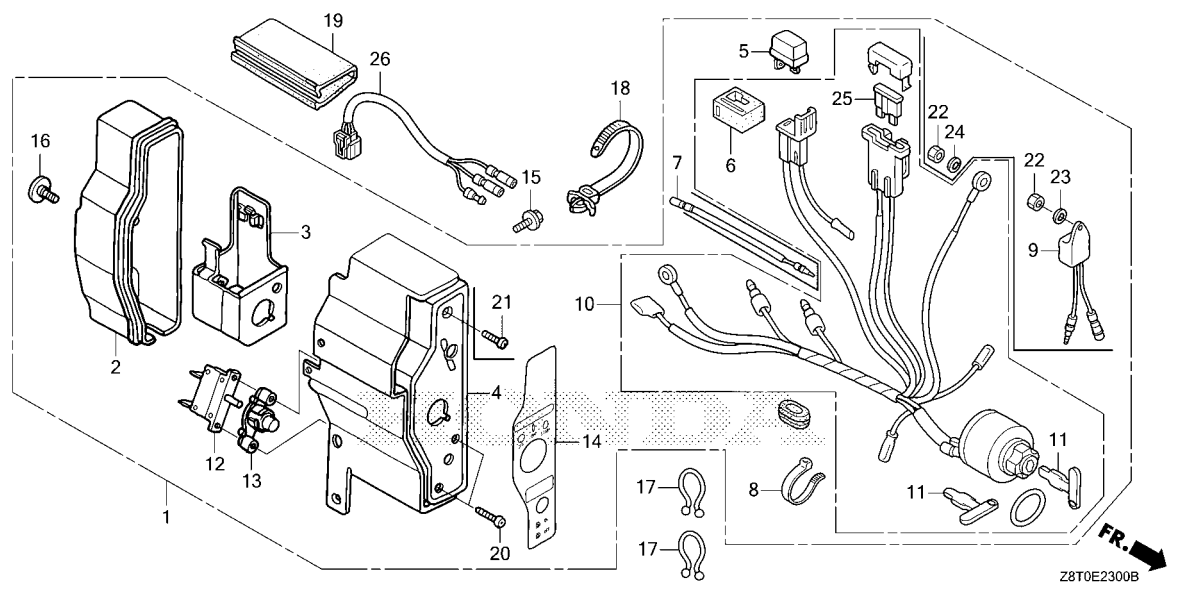

Ref. No.	Part No.	Description	Reqd. QTY					Serial No.	Parts catalogue code
			GX 340 UT1	GX 340 UT2	GX 340 RT1	GX 340 RT2	GX 340 UT2X		
5	31700-124-008	RECTIFIER ASSY., SILICON (SHINDENGEN)	1	1	1	1	1	-----	LXE4, LXE8, QAE2, QAE2/A, QAE6, QAE6/A, QXE4, QXE4/A, QXE6, QXE8, SXE4, SXE4/A, SXE8, VWE2, VWE2/A, VXE2, VXE2/A, VXE7, VXE8, VXE8/A, VXE9
6	32127-738-700	SUSPENSION, COUPLER.....	1	1	1	1	1	-----	LXE4, LXE8, QAE2, QAE2/A, QAE6, QAE6/A, QXE4, QXE4/A, QXE6, QXE8, SXE4, SXE4/A, SXE8, VWE2, VWE2/A, VXE2, VXE2/A, VXE7, VXE8, VXE8/A, VXE9
7	32197-ZE1-003	HARNESS, SUB WIRE.....	1	-	1	-	-	-----	LXE4, LXE8, QAE2, QAE6, QXE4, QXE6, QXE8, SXE4, SXE8, VWE2, VXE2, VXE7, VXE8, VXE9
8	32902-892-003	BAND.....	1	1	1	1	1	-----	LXE4, LXE8, QAE2, QAE2/A, QAE6, QAE6/A, QXE4, QXE4/A, QXE6, QXE8, SXE4, SXE4/A, SXE8, VWE2, VWE2/A, VXE2, VXE2/A, VXE7, VXE8, VXE8/A, VXE9
9	34150-ZH7-013	ALERT UNIT, OIL.....	1	-	1	-	-	-----	LXE4, LXE8, QAE2, QAE6, QXE4, QXE6, QXE8, SXE4, SXE8, VWE2, VXE2, VXE7, VXE8, VXE9
10	35100-ZE2-033	SWITCH ASSY., COMBINATION....	1	-	1	-	-	-----	LXE4, LXE8, QXE4, QXE6, QXE8, SXE4, SXE8, VWE2, VXE2, VXE7, VXE8, VXE9
	35100-ZE2-843	SWITCH ASSY., COMBINATION (3A-CHARGE)	1	-	-	-	-	-----	QAE2, QAE6
	35100-Z5T-811	SWITCH ASSY., COMBINATION....	-	1	-	1	1	-----	LXE4, QXE4, QXE4/A, QXE6, QXE8, SXE4, SXE4/A, SXE8, VWE2, VWE2/A, VXE2, VXE2/A, VXE8, VXE8/A, VXE9
	35100-Z5T-821	SWITCH ASSY., COMBINATION (3A-CHARGE)	-	1	-	-	1	-----	QAE2, QAE2/A, QAE6, QAE6/A
11	35111-880-013	KEY COMP.(HONDA LOCK).....	2	2	2	2	2	-----	LXE4, LXE8, QAE2, QAE2/A, QAE6, QAE6/A, QXE4, QXE4/A, QXE6, QXE8, SXE4, SXE4/A, SXE8, VWE2, VWE2/A, VXE2, VXE2/A, VXE7, VXE8, VXE8/A, VXE9
12	38240-VA3-900	PROTECTOR, CIRCUIT(1.0A).....	1	1	1	1	1	-----	LXE4, LXE8, QXE4, QXE4/A, QXE6, QXE8, SXE4, SXE4/A, SXE8, VWE2, VWE2/A, VXE2, VXE2/A, VXE7, VXE8, VXE8/A, VXE9



E-23

CONTROL BOX(1)

Ref. No.	Part No.	Description	Reqd. QTY					Serial No.	Parts catalogue code	
			GX 340 UT1	GX 340 UT2	GX 340 RT1	GX 340 RT2	GX 340 UT2X			
12)	38240-ZE2-840	PROTECTOR, CIRCUIT(3.5A).....	1	1	-	-	1	-----	-----	QAE2, QAE2/A, QAE6, QAE6/A
13	38250-ZA8-701	LENS ASSY., PROTECTOR.....	1	1	1	1	1	-----	-----	LXE4, LXE8, QAE2, QAE2/A, QAE6, QAE6/A, QXE4, QXE4/A, QXE6, QXE8, SXE4, SXE4/A, SXE8, VWE2, VWE2/A, VXE2, VXE2/A, VXE7, VXE8, VXE8/A, VXE9
14	87529-Z4T-840	MARK, CONTROL BOX(EXTERNAL)...	1	1	1	1	1	-----	-----	LXE4, LXE8, QAE2, QAE2/A, QAE6, QAE6/A, QXE4, QXE4/A, QXE6, QXE8, SXE4, SXE4/A, SXE8, VWE2, VWE2/A, VXE2, VXE2/A, VXE7, VXE8, VXE8/A, VXE9
15	90013-883-000	BOLT, FLANGE, 6X12(CT200).....	2	2	2	2	2	-----	-----	LXE4, LXE8, QAE2, QAE2/A, QAE6, QAE6/A, QXE4, QXE4/A, QXE6, QXE8, SXE4, SXE4/A, SXE8, VWE2, VWE2/A, VXE2, VXE2/A, VXE7, VXE8, VXE8/A, VXE9
16	90380-MA6-010	SCREW, SPECIAL, 6X12.....	1	1	1	1	1	-----	-----	LXE4, LXE8, QAE2, QAE2/A, QAE6, QAE6/A, QXE4, QXE4/A, QXE6, QXE8, SXE4, SXE4/A, SXE8, VWE2, VWE2/A, VXE2, VXE2/A, VXE7, VXE8, VXE8/A, VXE9
17	90630-751-000	CLIP, PURSE LOCK.....	1	2	1	2	2	-----	-----	LXE4, LXE8, QAE2, QAE2/A, QAE6, QAE6/A, QXE4, QXE4/A, QXE6, QXE8, SXE4, SXE4/A, SXE8, VWE2, VWE2/A, VXE2, VXE2/A, VXE7, VXE8, VXE8/A, VXE9
18	90672-SA0-003	STRAP, CABLE, 118MM(BLACK)...	1	1	1	1	1	-----	-----	LXE4, LXE8, QAE2, QAE2/A, QAE6, QAE6/A, QXE4, QXE4/A, QXE6, QXE8, SXE4, SXE4/A, SXE8, VWE2, VWE2/A, VXE2, VXE2/A, VXE7, VXE8, VXE8/A, VXE9
19	91406-ZE2-003	TUBE, FASTENER, 30MM.....	1	1	1	1	1	-----	-----	LXE4, LXE8, QAE2, QAE2/A, QAE6, QAE6/A, QXE4, QXE4/A, QXE6, QXE8, SXE4, SXE4/A, SXE8, VWE2, VWE2/A, VXE2, VXE2/A, VXE7, VXE8, VXE8/A, VXE9
20	93500-03012-0H	SCREW, PAN, 3X12.....	2	2	2	2	2	-----	-----	LXE4, LXE8, QAE2, QAE2/A, QAE6, QAE6/A, QXE4, QXE4/A, QXE6, QXE8, SXE4, SXE4/A, SXE8, VWE2, VWE2/A, VXE2, VXE2/A, VXE7, VXE8, VXE8/A, VXE9
21	93500-04012-0H	SCREW, PAN, 4X12.....	1	-	1	-	-	-----	-----	LXE4, LXE8, QAE2, QAE6, QXE4, QXE6, QXE8, SXE4, SXE8, VWE2, VXE2, VXE7, VXE8, VXE9
22	94001-04390-0S	NUT, HEX., 4MM.....	2	-	2	-	-	-----	-----	LXE4, LXE8, QAE2, QAE6, QXE4, QXE6, QXE8, SXE4, SXE8, VWE2, VXE2, VXE7, VXE8, VXE9
23	94101-04800	WASHER, PLAIN, 4MM.....	1	-	1	-	-	-----	-----	LXE4, LXE8, QAE2, QAE6, QXE4, QXE6, QXE8, SXE4, SXE8, VWE2, VXE2, VXE7, VXE8, VXE9
24	94111-04800	WASHER, SPRING, 4MM.....	1	-	1	-	-	-----	-----	LXE4, LXE8, QAE2, QAE6, QXE4, QXE6, QXE8, SXE4, SXE8, VWE2, VXE2, VXE7, VXE8, VXE9
25	98200-30500	FUSE, BLADE(5A).....	1	1	1	1	1	-----	-----	LXE4, LXE8, QXE4, QXE4/A, QXE6, QXE8, SXE4, SXE4/A, SXE8, VWE2, VWE2/A, VXE2, VXE2/A, VXE7, VXE8, VXE8/A, VXE9
	98200-31500	FUSE, BLADE(15A).....	1	1	-	-	1	-----	-----	QAE2, QAE2/A, QAE6, QAE6/A
26	32110-Z5K-810	HARNESS ASSY., ENGINE WIRE (SEL)	-	1	-	1	-	-----	-----	EDE2/A, EDS6/A, QAE2/A, QAE6/A, QXE4/A, SXE4/A, VWE/A, VWE2/A, VXE2/A, VXE8/A
	32110-Z5K-800	HARNESS ASSY., ENGINE WIRE...	-	1	-	-	1	-----	-----	QE, QE/A, QHB4, QHB4/A, QHQ4, SE, SE/A, SE1, SHQ4, SHQ4/A
	32110-Z5T-810	HARNESS ASSY., ENGINE WIRE (SEL)	-	1	-	-	-	-----	1074364	LXE4, QAE2, QAE6, QXE4, QXE6, QXE8, SXE4, SXE8, VXE2, VXE8, VXE9
	32110-Z5K-810	-	1	-	-	-	-----	1074365	LXE4, QAE2, QAE6, QXE4, QXE6, QXE8, SXE4, SXE8, VXE2, VXE8, VXE9
	32110-Z5T-810	-	-	-	1	-	-----	1076216	EDE2, EDS6, VWE, VWE2
	32110-Z5K-810	-	-	-	1	-	-----	1076217	EDE2, EDS6, VWE, VWE2
			-	-	-	-	1	-----	-----	QAE2, QAE6, QXE4, SXE4, VXE8



E-23-1

CONTROL BOX(2)

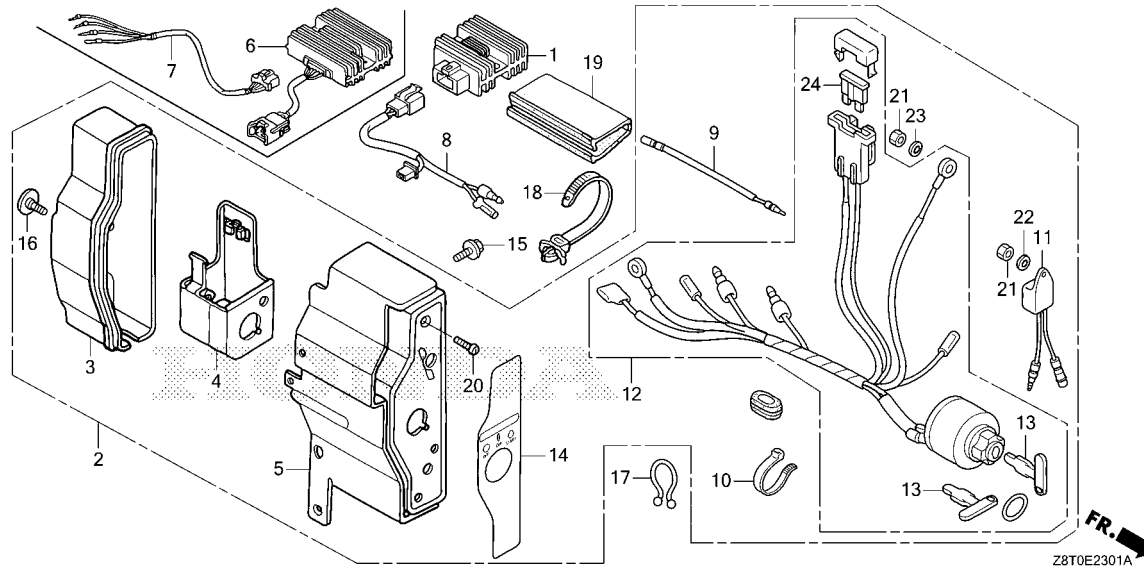

Ref. L.O.N. (Relative ref. Number) F.R.T.
 No. Description

Ref. No.	Part No.	Description	Reqd. QTY					Serial No.	Parts catalogue code
			GX 340 UT1	GX 340 UT2	GX 340 RT1	GX 340 RT2	GX 340 UT2X		
1	31600-ZE2-861	RECTIFIER ASSY., REGULATOR (10A)	1	-	1	-	-	-----	QNB2, QNE2, SME0
2	31610-Z5S-821ZB	BOX ASSY., CONTROL(EXP-ALERT) (10A)	1	-	-	-	-	-----	QNE2, SME0
		R280.....POWER RED	1	-	-	-	-	-----	QNE2, SME0
	31610-Z5R-821ZA	BOX ASSY., CONTROL(EXP-ALERT) (18A)	1	-	-	-	-	-----	QNR2
		NH1.....BLACK	1	-	-	-	-	-----	QNR2
	31610-Z5R-821ZB	*R280*.....POWER RED	1	-	-	-	-	-----	QNR2, QNR6
	31610-Z5S-821ZA	BOX ASSY., CONTROL(EXP-ALERT) (10A)	1	-	-	-	-	-----	SME0
		NH1.....BLACK	1	-	-	-	-	-----	QNE2, QNR2, QNR6, SME0
3	31612-ZE2-003	CASE, CONTROL	1	-	-	-	-	-----	QNE2, QNR2, QNR6, SME0
4	31614-ZE2-003	BRACKET, CASE MOUNTING	1	-	-	-	-	-----	QNE2, QNR2, QNR6, SME0
5	31615-ZE3-003ZE	PANEL COMP., CONTROL	1	-	-	-	-	-----	QNE2, QNR2, QNR6, SME0
		R280.....POWER RED	1	-	-	-	-	-----	QNE2, QNR2, QNR6, SME0
	31615-ZE3-003ZA	*NH1*.....BLACK	1	-	-	-	-	-----	QNR2, SME0
6	31620-ZG5-033	RECTIFIER ASSY., REGULATOR (20A)	1	-	-	-	-	-----	QNR2, QNR6
7	32110-ZE2-W00	HARNESS ASSY., SUB WIRE	1	-	-	-	-	-----	QNR2, QNR6
8	32110-ZE2-860	HARNESS ASSY., SUB WIRE	1	-	1	-	-	-----	QNB2, QNE2, SME0
9	32197-ZE1-003	HARNESS, SUB WIRE	1	-	-	-	-	-----	QNE2, QNR2, QNR6, SME0
10	32902-892-003	BAND	1	-	-	-	-	-----	QNE2, QNR2, QNR6, SME0
11	34150-ZH7-013	ALERT UNIT, OIL	1	-	-	-	-	-----	QNE2, QNR2, QNR6, SME0
12	35100-ZE2-862	SWITCH ASSY., COMBINATION (10A-CHARGE)	1	-	-	-	-	-----	QNE2, SME0

E-23-1

CONTROL BOX(2)

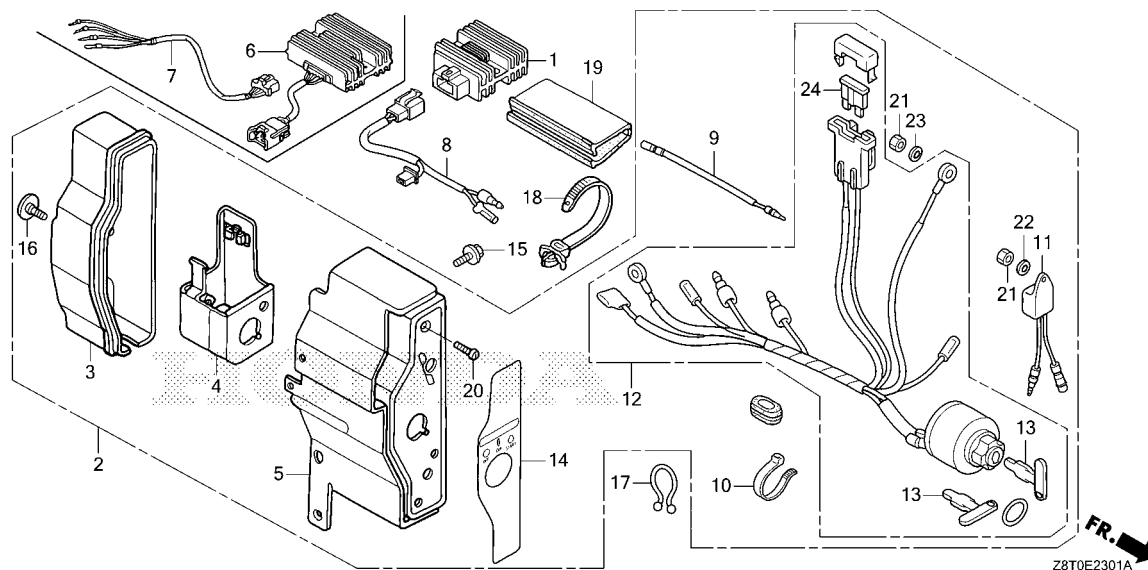

Z8T0E2301A

Ref. No.	Part No.	Description	Reqd. QTY					Serial No.	Parts catalogue code
			GX 340 UT1	GX 340 UT2	GX 340 RT1	GX 340 RT2	GX 340 UT2X		
12)	35100-ZE2-W01	SWITCH ASSY., COMBINATION (18A-CHARGE)	1	-	-	-	-	-----	QNR2, QNR6
13	35111-880-013	KEY COMP.(HONDA LOCK).....	2	-	-	-	-	-----	QNE2, QNR2, QNR6, SME0
14	87529-Z4S-820	MARK, CONTROL BOX(EXP).....	1	-	-	-	-	-----	QNE2, QNR2, QNR6, SME0
15	90013-883-000	BOLT, FLANGE, 6X12(CT200)....	2	-	-	-	-	-----	QNE2, QNR2, QNR6, SME0
16	90380-MA6-010	SCREW, SPECIAL, 6X12.....	1	-	-	-	-	-----	QNE2, QNR2, QNR6, SME0
17	90630-751-000	CLIP, PURSE LOCK.....	1	-	-	-	-	-----	QNE2, QNR2, QNR6, SME0
18	90672-SA0-003	STRAP, CABLE, 118MM(BLACK)...	1	-	-	-	-	-----	QNE2, QNR2, QNR6, SME0
19	91406-ZE2-003	TUBE, FASTENER, 30MM.....	1	-	-	-	-	-----	QNE2, QNR2, QNR6, SME0
20	93500-04012-0H	SCREW, PAN, 4X12.....	1	-	-	-	-	-----	QNE2, QNR2, QNR6, SME0
21	94001-04390-0S	NUT, HEX., 4MM.....	2	-	-	-	-	-----	QNE2, QNR2, QNR6, SME0
22	94101-04800	WASHER, PLAIN, 4MM.....	1	-	-	-	-	-----	QNE2, QNR2, QNR6, SME0
23	94111-04800	WASHER, SPRING, 4MM.....	1	-	-	-	-	-----	QNE2, QNR2, QNR6, SME0
24	98200-31500	FUSE, BLADE(15A).....	1	-	-	-	-	-----	QNE2, SME0
	98200-32500	FUSE, BLADE(25A).....	1	-	-	-	-	-----	QNR2, QNR6



E-23-2

CONTROL BOX(3)

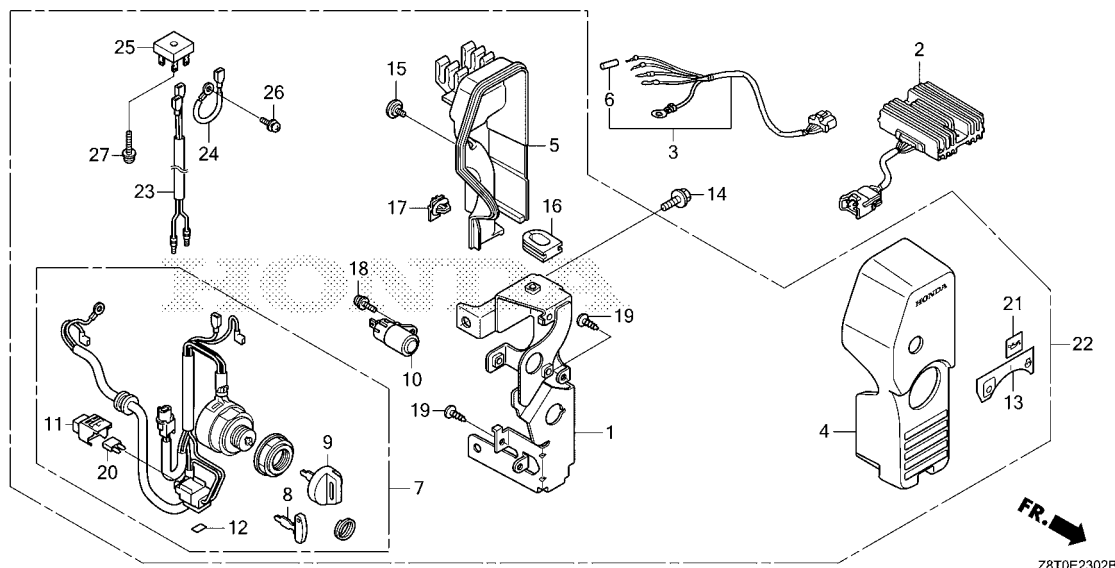

Ref. L.O.N. (Relative ref. Number) F.R.T.
 No. Description

Ref. No.	Part No.	Description	Reqd. QTY					Serial No.	Parts catalogue code
			GX 340 UT1	GX 340 UT2	GX 340 RT1	GX 340 RT2	GX 340 UT2X		
1	31614-Z5T-W00	BRACKET, SWITCH BOX.....	-	1	-	-	-	QZA2, QZAV, QZN2, QZX4	
2	31750-Z0A-811	RECTIFIER ASSY., REGULATOR...	-	1	-	-	-	QZN2	
3	32105-ZJ1-800	HARNESS ASSY., SUB WIRE.....	-	1	-	-	-	QZN2	
4	32346-Z5T-W00	PANEL, CONTROL.....	-	1	-	-	-	QZA2, QZAV, QZN2, QZX4	
5	32612-Z5T-W00	COVER, CONTROL.....	-	1	-	-	-	QZA2, QZAV, QZN2, QZX4	
6	32824-ZV5-003	PLUG, OUTER CONNECTOR.....	-	1	-	-	-	QZN2	
7	35100-Z5T-W01	SWITCH ASSY., COMBINATION(IND)	-	1	-	-	-	QZA2, QZAV, QZX4	
	35100-Z5T-W21	-	1	-	-	-	QZN2	
8	35110-Z5T-W01	KEY COMP.....	-	1	-	-	-	QZA2, QZAV, QZN2, QZX4	
9	35110-Z5T-W11	KEY ASSY., COMBINATION SWITCH (BLACK)	-	1	-	-	-	QZA2, QZAV, QZN2, QZX4	
10	37150-Z5T-W01	INDICATOR ASSY.....	-	1	-	-	-	QZA2, QZAV, QZN2, QZX4	
11	38216-Z2E-003	COVER ASSY., FUSE.....	-	1	-	-	-	QZA2, QZAV, QZN2, QZX4	
12	87117-Z2E-800	LABEL, FUSE(30A).....	-	1	-	-	-	QZA2, QZAV, QZN2, QZX4	
13	87501-Z5T-W00	MARK, ENGINE SWITCH.....	-	1	-	-	-	QZA2, QZAV, QZN2, QZX4	
14	90013-883-000	BOLT, FLANGE, 6X12(CT200)....	-	2	-	-	-	QZA2, QZAV, QZN2, QZX4	
15	90380-MB2-000	SCREW, SPECIAL, 6X8.....	-	1	-	-	-	QZA2, QZAV, QZN2, QZX4	
16	90601-Z5T-W00	GROMMET, CONTROL BOX.....	-	1	-	-	-	QZA2, QZAV, QZN2, QZX4	
17	91565-SEL-003	CLIP, COUPLER(BLACK).....	-	1	-	-	-	QZA2, QZAV, QZN2, QZX4	
18	93891-04010-08	SCREW-WASHER, 4X10.....	-	1	-	-	-	QZA2, QZAV, QZN2, QZX4	
19	93913-24310	SCREW, TAPPING, 4X14(PO).....	-	2	-	-	-	QZA2, QZAV, QZN2, QZX4	
20	98200-43000	FUSE, MINI(30A).....	-	1	-	-	-	QZA2, QZAV, QZN2, QZX4	
21	87594-Z5T-W00	MARK, OIL CAUTION.....	-	1	-	-	-	QZA2, QZAV, QZN2, QZX4	
22	31610-Z5T-W00	BOX ASSY., CONTROL.....	-	1	-	-	-	QZA2, QZAV, QZX4	
23	31711-Z5T-W00	CORD, CHARGE COIL.....	-	1	-	-	-	QZA2, QZAV, QZX4	

E-23-2

CONTROL BOX(3)

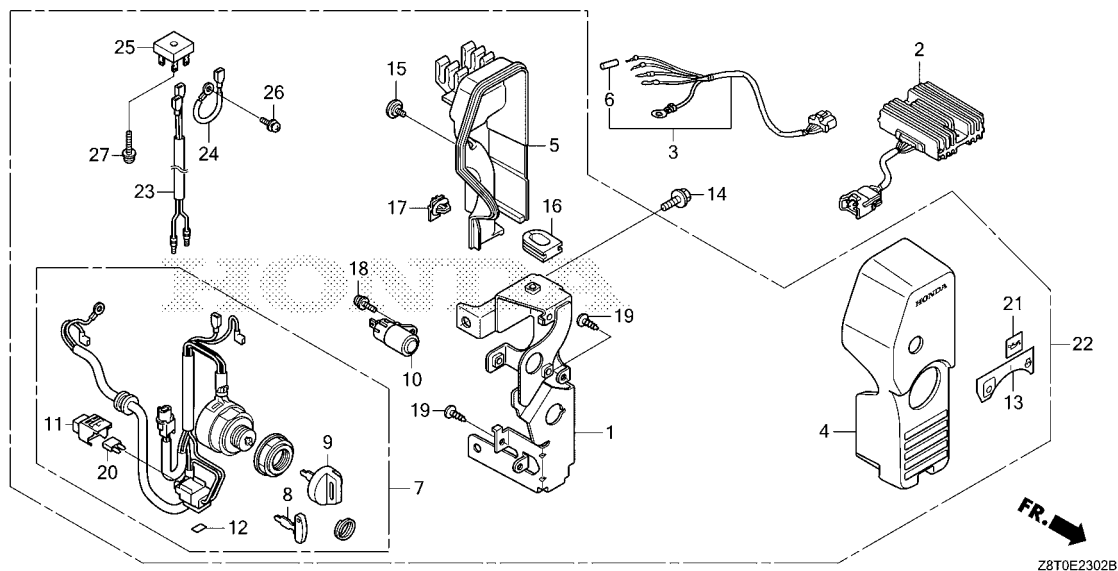

Ref. No.	Part No.	Description	Reqd. QTY					Serial No.	Parts catalogue code
			GX 340 UT1	GX 340 UT2	GX 340 RT1	GX 340 RT2	GX 340 UT2X		
24	31712-Z5T-W00	CORD, EARTH.....	-	1	-	-	-	QZA2, QZAV, QZX4	
25	31713-Z5T-W01	RECTIFIER COMP.....	-	1	-	-	-	QZA2, QZAV, QZX4	
26	93891-04008-08	SCREW-WASHER, 4X8.....	-	1	-	-	-	QZA2, QZAV, QZX4	
27	93893-04020-08	SCREW-WASHER, 4X20.....	-	1	-	-	-	QZA2, QZAV, QZX4	



E-23-3

CONTROL BOX(4)

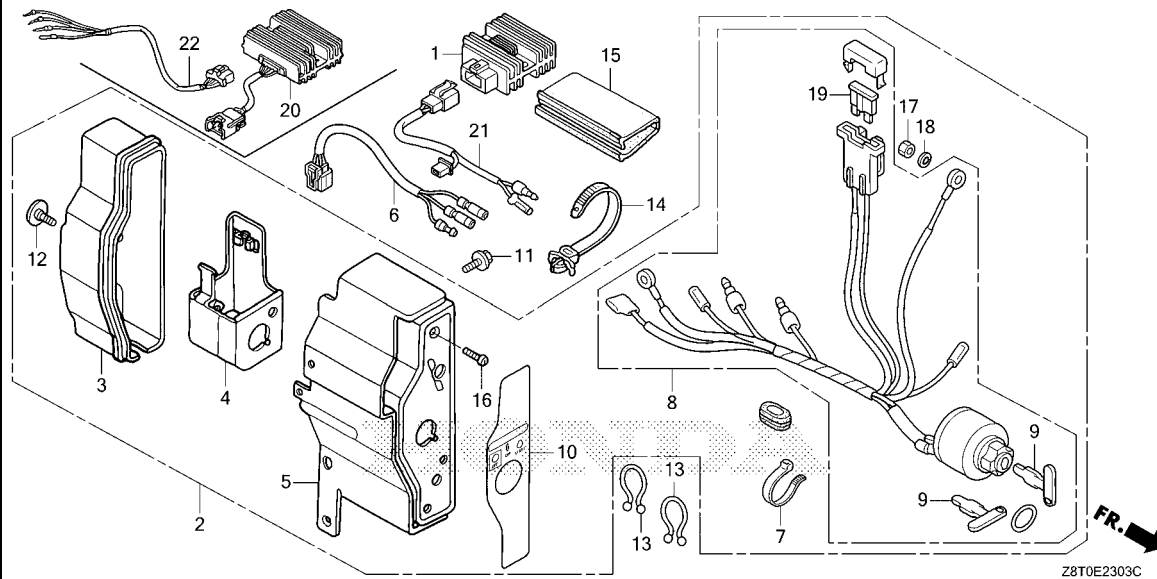

Ref. L.O.N. (Relative ref. Number) F.R.T.
No. Description

Ref. No.	Part No.	Description	Reqd. QTY					Serial No.	Parts catalogue code
			GX 340 UT1	GX 340 UT2	GX 340 RT1	GX 340 RT2	GX 340 UT2X		
1	31600-ZE2-861	RECTIFIER ASSY., REGULATOR (10A)	-	1	-	1	1	-----	QNB2, QNE2, QNE2/A, SME0, SME0/A
2	31610-Z5T-831ZB	BOX ASSY., CONTROL(10A)	-	1	-	-	1	-----	QNE2, QNE2/A, SME0, SME0/A
	R280POWER RED	-	1	-	-	1	-----	QNE2, QNE2/A, SME0, SME0/A
	31610-Z5T-841ZA	BOX ASSY., CONTROL(18A)	-	1	-	-	1	-----	QNR2, QNR2/A
	NH1BLACK	-	1	-	-	1	-----	QNR2, QNR2/A
	31610-Z5T-841ZB	*R280*.....POWER RED	-	1	-	-	1	-----	QNE2, QNE2/A, QNR2, QNR2/A, SME0, SME0/A
	31610-Z5T-831ZA	BOX ASSY., CONTROL(10A)	-	1	-	-	1	-----	QNE2, QNE2/A, QNR2, QNR2/A, SME0, SME0/A
	NH1BLACK	-	1	-	-	1	-----	QNR2, QNR2/A, SME0, SME0/A
3	31612-ZE2-003	CASE, CONTROL	-	1	-	-	1	-----	QNE2, QNE2/A, QNR2, QNR2/A, SME0, SME0/A
4	31614-ZE2-003	BRACKET, CASE MOUNTING	-	1	-	-	1	-----	QNE2, QNE2/A, QNR2, QNR2/A, SME0, SME0/A
5	31615-ZE3-003ZE	PANEL COMP., CONTROL	-	1	-	-	1	-----	QNE2, QNE2/A, QNR2, QNR2/A, SME0, SME0/A
	R280POWER RED	-	1	-	-	1	-----	QNE2, QNE2/A, QNR2, QNR2/A, SME0, SME0/A
	31615-ZE3-003ZA	*NH1*.....BLACK	-	1	-	-	1	-----	QNR2, QNR2/A, SME0, SME0/A
6	32110-Z5K-000	HARNESS ASSY., ENGINE WIRE	-	1	-	1	-	-----	EDN2/A, EDT6/A, HA2/A, HX26/A, LXQ4/A, PKT2/A, PKX2/A, QA2/A, QAH2/A, QAP2/A, QKA4/A, QMT2/A, QWC/A, QXB7/A, QXQ4/A, QXU/A, SXQ4/A, VWC/A, VWS1, VWS1/A, VX16/A, VX8/A
	32110-Z5K-810	HARNESS ASSY., ENGINE WIRE (SEL)	-	1	-	-	-	-----	QNE2/A, QNR2/A, SE2, SME0/A
	32110-Z5T-810	-	1	-	-	-	1074364	QNE2, QNR2, SME0
	32110-Z5T-000	HARNESS ASSY., ENGINE WIRE	-	1	-	-	-	1074760	HA2, HX26, LX2, LXQ4, LXU, PKT2, PKX2, QA2, QAG, QAH2, QAP2, QDW9, QKA4, QMT2, QWC, QXB7, QXB9, QXC9, QXQ4, QXU, SMX2, SXQ4, VA2, VX16, VX8, VXB7, VXB9
	32110-Z5K-810	HARNESS ASSY., ENGINE WIRE (SEL)	-	1	-	-	-	1074365	QNE2, QNR2, SME0
	32110-Z5K-000	HARNESS ASSY., ENGINE WIRE	-	1	-	-	-	1074761	HA2, HX26, LX2, LXQ4, LXU, PKT2, PKX2, QA2, QAG, QAH2, QAP2, QDW9, QKA4, QMT2, QWC, QXB7, QXB9, QXC9, QXQ4, QXU, SMX2, SXQ4, VA2, VX16, VX8, VXB7, VXB9

E-23-3

CONTROL BOX(4)

Ref. No.	Part No.	Description	Reqd. QTY					Serial No.	Parts catalogue code
			GX 340 UT1	GX 340 UT2	GX 340 RT1	GX 340 RT2	GX 340 UT2X		
(6)	32110-Z5T-000	HARNESS ASSY., ENGINE WIRE ...	-	-	-	1	-	----- 1075630 EDN2, EDT6, VDE2, VWC, VWS	
	32110-Z5T-810	HARNESS ASSY., ENGINE WIRE (SEL)	-	-	-	1	-	----- 1076216 QNB2	
	32110-Z5K-000	HARNESS ASSY., ENGINE WIRE ...	-	-	-	1	-	----- 1075631 ----- EDN2, EDT6, VDE2, VWC, VWS	
	32110-Z5K-810	HARNESS ASSY., ENGINE WIRE (SEL)	-	-	-	1	-	----- 1076217 ----- QNB2	
	32110-Z5K-000	HARNESS ASSY., ENGINE WIRE ...	-	-	-	-	1	----- ----- HA2, HX26, LXQ4, PKT2, PKX2, QA2, QAH2, QAP2, QKA4, QMT2, QWC, QXB7 QXQ4, SXQ4, VX8	
	32110-Z5K-810	HARNESS ASSY., ENGINE WIRE (SEL)	-	-	-	-	1	----- ----- QNE2, QNR2, SE2, SME0	
7	32902-892-003	BAND	-	1	-	-	1	----- ----- QNE2, QNE2/A, QNR2, QNR2/A, SME0, SME0/A	
8	35100-Z5T-831	SWITCH ASSY., COMBINATION(10A)	-	1	-	-	1	----- ----- QNE2, QNE2/A, SME0, SME0/A	
	35100-Z5T-841	SWITCH ASSY., COMBINATION(18A)	-	1	-	-	1	----- ----- QNR2, QNR2/A	
9	35111-880-013	KEY COMP.(HONDA LOCK)	-	2	-	-	2	----- ----- QNE2, QNE2/A, QNR2, QNR2/A, SME0, SME0/A	
10	87529-Z4S-820	MARK, CONTROL BOX(EXP)	-	1	-	-	1	----- ----- QNE2, QNE2/A, QNR2, QNR2/A, SME0, SME0/A	
11	90013-883-000	BOLT, FLANGE, 6X12(CT200)	-	2	-	-	2	----- ----- QNE2, QNE2/A, QNR2, QNR2/A, SME0, SME0/A	
12	90380-MA6-010	SCREW, SPECIAL, 6X12	-	1	-	-	1	----- ----- QNE2, QNE2/A, QNR2, QNR2/A, SME0, SME0/A	
13	90630-751-000	CLIP, PURSE LOCK	-	1	-	-	1	----- ----- SE2	
			-	2	-	-	-	----- ----- QNE2, QNE2/A, QNR2, QNR2/A, SME0, SME0/A	
			-	-	-	1	-	----- ----- QNB2	
			-	-	-	-	2	----- ----- QNE2, QNR2, SME0	
14	90672-SA0-003	STRAP, CABLE, 118MM(BLACK) ...	-	1	-	-	1	----- ----- QNE2, QNE2/A, QNR2, QNR2/A, SME0, SME0/A	
15	91406-ZE2-003	TUBE, FASTENER, 30MM	-	1	-	-	1	----- ----- QNE2, QNE2/A, QNR2, QNR2/A, SME0, SME0/A	
16	93500-04012-0H	SCREW, PAN, 4X12	-	1	-	-	1	----- ----- QNE2, QNE2/A, QNR2, QNR2/A, SME0, SME0/A	
17	94001-04390-0S	NUT, HEX., 4MM	-	1	-	-	1	----- ----- QNE2, QNE2/A, QNR2, QNR2/A, SME0, SME0/A	
18	94111-04800	WASHER, SPRING, 4MM	-	1	-	-	1	----- ----- QNE2, QNE2/A, QNR2, QNR2/A, SME0, SME0/A	
19	98200-31500	FUSE, BLADE(15A)	-	1	-	-	1	----- ----- QNE2, QNE2/A, SME0, SME0/A	
	98200-32500	FUSE, BLADE(25A)	-	1	-	-	1	----- ----- QNR2, QNR2/A	
20	31620-ZG5-033	RECTIFIER ASSY., REGULATOR (20A)	-	1	-	-	1	----- ----- QAH2, QAH2/A, QNR2, QNR2/A	
21	32110-ZE2-860	HARNESS ASSY., SUB WIRE	-	1	-	1	-	----- 1025358 ----- QNB2, QNE2, SME0	
			-	1	-	-	-	----- ----- QNE2/A, SME0/A	
			-	-	-	-	1	----- ----- QNE2, SME0	
22	32110-ZE2-W00	HARNESS ASSY., SUB WIRE	-	1	-	-	-	----- QAH2/A, QNR2/A	
			-	1	-	-	-	----- 1001763 ----- QAH2, QNR2	
			-	-	-	-	1	----- ----- QAH2, QNR2	



E-26

REDUCTION(1)

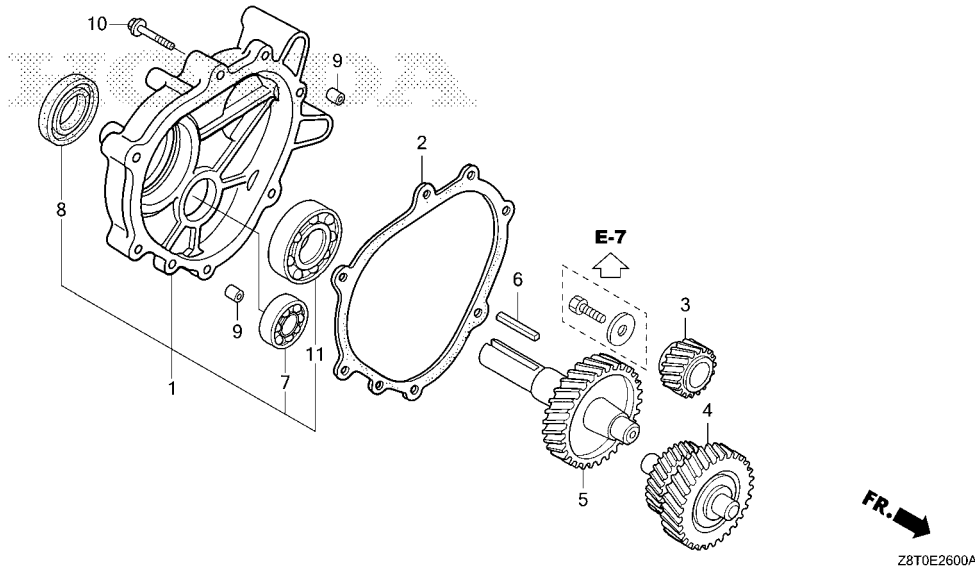

Ref. L.O.N. (Relative ref. Number) F.R.T.
 No. Description

Ref. No.	Part No.	Description	Reqd. QTY					Serial No.	Parts catalogue code
			GX 340 UT1	GX 340 UT2	GX 340 RT1	GX 340 RT2	GX 340 UT2X		
1	11500-Z8T-612	COVER ASSY., GEAR CASE.....	1	1	-	-	1	-----	LX2, LXE4, LXE8, LXQ4, LXQ4/A, LXU
2	11521-ZE2-800	PACKING, CHAIN CASE COVER....	1	1	-	-	1	-----	LX2, LXE4, LXE8, LXQ4, LXQ4/A, LXU
3	22103-ZE3-610	GEAR, PRIMARY DRIVE(22T).....	1	1	-	-	-	-----	LX2, LXE4, LXE8, LXQ4, LXQ4/A, LXU
4	23411-Z1C-000	-	-	-	-	1	-----	LXQ4
4	23220-ZE3-610	COUNTERSHAFT COMP.(21T/27T)...	1	1	-	-	1	-----	LX2, LXE4, LXE8, LXQ4, LXQ4/A, LXU
5	23710-ZE3-610	SHAFT, P.T.O.(33T).....	1	1	-	-	1	-----	LX2, LXE4, LXE8, LXQ4, LXQ4/A, LXU
6	90741-805-000	KEY, 7X7X33.....	1	1	-	-	1	-----	LX2, LXE4, LXE8, LXQ4, LXQ4/A, LXU
	90741-889-810	KEY, 7X7X33(YELLOW)(O.S.)....	(1)	(1)	-	-	(1)	-----	LX2, LXE4, LXE8, LXQ4, LXQ4/A, LXU
7	91009-KJ1-003	BEARING, RADIAL BALL, 6202 (NTN)	1	1	-	-	1	-----	LX2, LXE4, LXE8, LXQ4, LXQ4/A, LXU
8	91201-Z1D-003	OIL SEAL, 30X46X8(NOK ASIA)...	1	1	-	-	1	-----	LX2, LXE4, LXE8, LXQ4, LXQ4/A, LXU
9	94301-08140	DOWEL PIN, 8X14.....	2	2	-	-	2	-----	LX2, LXE4, LXE8, LXQ4, LXQ4/A, LXU
10	95701-08040-00	BOLT, FLANGE, 8X40.....	6	6	-	-	6	-----	LX2, LXE4, LXE8, LXQ4, LXQ4/A, LXU
11	96100-62060-00	BEARING, RADIAL BALL, 6206...	1	1	-	-	1	-----	LX2, LXE4, LXE8, LXQ4, LXQ4/A, LXU

E-26-1

REDUCTION(2)

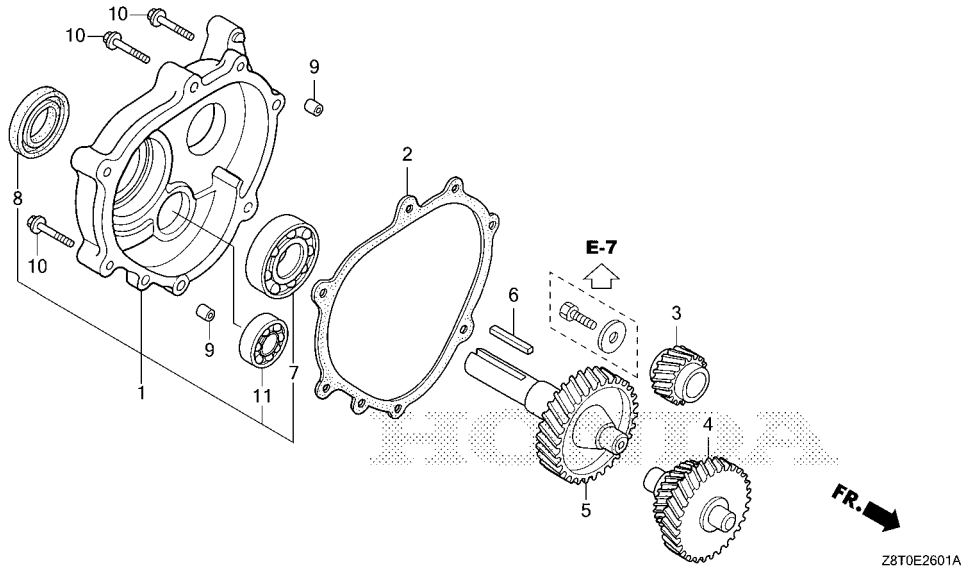

Ref. L.O.N. (Relative ref. Number) F.R.T.
 No. Description

Ref. No.	Part No.	Description	Reqd. QTY					Serial No.	Parts catalogue code
			GX 340 UT1	GX 340 UT2	GX 340 RT1	GX 340 RT2	GX 340 UT2X		
1	11500-Z8T-640	COVER ASSY., GEAR CASE.....	1	1	-	-	1	-----	HA2, HA2/A, HX26, HX26/A
2	11521-ZE2-800	PACKING, CHAIN CASE COVER....	1	1	-	-	1	-----	HA2, HA2/A, HX26, HX26/A
3	22103-ZE3-640	GEAR, PRIMARY DRIVE(12T).....	1	1	-	-	1	-----	HA2, HA2/A, HX26, HX26/A
4	23220-ZE3-640	COUNTERSHAFT COMP.(13T/27T)..	1	1	-	-	1	-----	HA2, HA2/A, HX26, HX26/A
5	23710-ZE3-640	SHAFT, P.T.O.(34T).....	1	1	-	-	1	-----	HA2, HA2/A, HX26, HX26/A
6	90745-ZE2-600	KEY, 6.3X6.3X43.....	1	1	-	-	1	-----	HA2, HA2/A, HX26, HX26/A
7	91006-MT3-003	BEARING, RADIAL BALL, 6206 (NTN)	1	1	-	-	1	-----	HA2, HA2/A, HX26, HX26/A
8	91201-Z1D-003	OIL SEAL, 30X46X8(NOK ASIA)..	1	1	-	-	1	-----	HA2, HA2/A, HX26, HX26/A
9	94301-08140	DOWEL PIN, 8X14.....	2	2	-	-	2	-----	HA2, HA2/A, HX26, HX26/A
10	95701-08040-00	BOLT, FLANGE, 8X40.....	6	6	-	-	6	-----	HA2, HA2/A, HX26, HX26/A
11	96100-63020-00	BEARING, RADIAL BALL, 6302...	1	1	-	-	1	-----	HA2, HA2/A, HX26, HX26/A



E-28

LABEL/TOOL

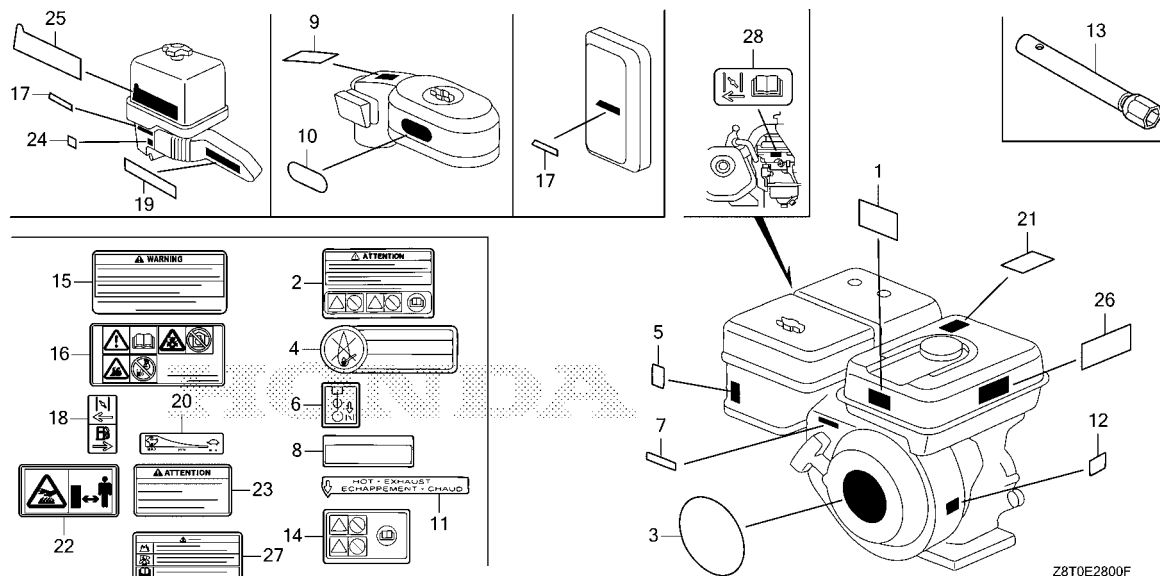

Ref. L.O.N. (Relative ref. Number) F.R.T.
 No. Description

Ref. No.	Part No.	Description	Reqd. QTY					Serial No.	Parts catalogue code
			GX 340 UT1	GX 340 UT2	GX 340 RT1	GX 340 RT2	GX 340 UT2X		
1	87516-Z4H-000	MARK, OPERATOR CAUTION (ENGLISH)(MADE IN THAI)	1	-	1	-	-	----- 1007578	
	87516-Z4H-010	1	-	1	-	-	----- 1007579	HA2, HX26, LXE8, LXQ4, PKT2, QA26, QAE6, QAH2, QNB2, QNR2, QNR6, QXC6, QXE6, QXE8, SXE4, SXE8, VA2, VAD2, VC2, VDE2, VW12, VWE2, VX16, VX8, VXE2, VXE8
	87519-Z4H-000	MARK, OPERATOR CAUTION (PICTOGRAPH)	1	-	-	-	-	----- 1007579	LXE4, QE, QHB4, QHQ4, QKA4, QXB7, QXB9, QXC4, QXE4, QXQ4, QXU, SE, SHQ4, SME0, SXE4, SXQ4, VXB7, VXB9, VXE7, VXE9
2	87516-Z4H-800	MARK, OPERATOR CAUTION(FRENCH) (MADE IN THAI)	1	-	1	-	-	----- 1007578	
3	87521-ZE3-W04	EMBLEM(GX340)	1	-	1	-	-	-----	
	87521-Z8T-000	-	1	-	1	1	-----	EDE2, EDE2/A, EDN2, EDN2/A, EDS6, EDS6/A, EDT6, EDT6/A, HA2, HA2/A, HX26, HX26/A, LX2, LXE4, LXQ4, LXQ4/A, LXU, PKT2, PKT2/A, PKX2, PKX2/A, QA2, QA2/A, QAE2, QAE2/A, QAE6, QAE6/A, QAG, QAH2, QAH2/A, QAP2, QAP2/A, QDW9, QE, QE/A, QHB4, QHB4/A, QHQ4, QKA4, QKA4/A, QMT2, QMT2/A, QNB2, QNE2, QNE2/A, QNR2, QNR2/A, QWC, QWC/A, QXB7, QXB7/A, QXB9, QXC9, QXE4, QXE4/A, QXE6, QXE8, QXQ4, QXQ4/A, QXU, QXU/A, SE, SE/A, SE1, SE2, SHQ4, SHQ4/A, SME0, SME0/A, SMX2, SXE4, SXE4/A, SXE8, SXQ4, SXQ4/A, VA2, VDE2, VVC, VVC/A, VWE, VWE/A, VWE2, VWE2/A, VWS, VWS1, VWS1/A, VX16, VX16/A, VX8, VX8/A, VXB7, VXB9, VXE2, VXE2/A, VXE8, VXE8/A, VXE9
4	87522-883-660	MARK, CAUTION (ENGLISH/FRENCH/SPANISH)	-	-	1	1	-	-----	EDS6, EDS6/A, EDT6, EDT6/A, VC2, VVC, VVC/A, VWE, VWE/A
5	87528-ZH7-000	MARK, CHOKE(GRAY)	1	-	1	-	-	-----	HA2, HX26, LX2, LXE4, LXE8, LXQ4, LXU, PKT2, QA2, QA26, QAE2, QAE6, QAG, QAH2, QAP2, QDW9, QE, QHB4, QHQ4, QKA4, QNB2, QNE2, QNR2, QNR6, QXB7, QXB9, QXC4, QXC6, QXC9, QXE4, QXE6, QXE8, QXQ4, QXU, SE, SHQ4, SME0, SXE4, SXE8, SXQ4, VA2, VAD2, VDE2, VW12, VWE2, VX16, VX8, VXB7, VXB9, VXE2, VXE7, VXE8, VXE9



E-28

LABEL/TOOL

Ref. No.	Part No.	Description	Reqd. QTY					Serial No.	Parts catalogue code
			GX 340 UT1	GX 340 UT2	GX 340 RT1	GX 340 RT2	GX 340 UT2X		
(5)	87528-Z5T-000	MARK, CHOKE.....	-	1	-	1	-	-----	HA2, HX26, LX2, LXE4, LXQ4, LXU, PKT2, PKX2, QAE6, QAH2, QE, QHB4, QHQ4, QKA4, QMT2, QNB2, QNR2, QXB7, QXB9, QXE4, QXE6, QXE8, QXQ4, QXU, QXU/A, SE, SHQ4, SHQ4/A, SME0, SMX2, SXE4, SXE8, SXQ4, VA2, VDE2, VWE2, VX16, VX16/A, VX8, VXB7, VXB9, VXE2, VXE2/A, VXE8, VXE9
			-	1	-	1	-	-----	2023400 HA2/A, HX26/A, LXQ4/A, PKT2/A, PKX2/A, QAE6/A, QAH2/A, QE/A, QHB4/A, QKA4/A, QMT2/A, QNR2/A, QXB7/A, QXE4/A, QXQ4/A, SE/A, SE1, SE2, SME0/A, SXE4/A, SXQ4/A, VWE2/A, VX8/A, VXE8/A
	87528-Z4M-000	-	1	-	1	-	2023401	----- HA2/A, HX26/A, LXQ4/A, PKT2/A, PKX2/A, QAE6/A, QAH2/A, QE/A, QHB4/A, QKA4/A, QMT2/A, QNR2/A, QXB7/A, QXE4/A, QXQ4/A, SE/A, SE1, SE2, SME0/A, SXE4/A, SXQ4/A, VWE2/A, VX8/A, VXE8/A
			-	-	-	-	1	-----	HA2, HX26, LXQ4, PKT2, PKX2, QAE6, QAH2, QE, QHB4, QKA4, QMT2, QNR2, QXB7, QXE4, QXQ4, SE, SE1, SE2, SME0, SXE4, SXQ4, VX8, VXE8
6	87528-898-620	MARK, CHOKE.....	-	-	1	1	-	-----	EDE2, EDE2/A, EDN2, EDN2/A, EDS6, EDS6/A, EDT6, EDT6/A, VC2, VWC, VWC/A, VWE, VWE/A, VWS, VWS1, VWS1/A
7	87532-ZH7-000	MARK, THROTTLE INDICATION....	1	-	1	1	-	-----	HA2, HX26, LX2, LXE4, LXE8, LXQ4, LXU, PKT2, QA2, QA26, QAE2, QAE6, QAG, QAH2, QAP2, QDW9, QE, QHB4, QHQ4, QKA4, QNB2, QNE2, QNR2, QNR6, QXB7, QXB9, QXC4, QXC6, QXC9, QXE4, QXE6, QXE8, QXQ4, QXU, SE, SHQ4, SME0, SXE4, SXE8, SXQ4, VA2, VAD2, VDE2, VX16, VXB7, VXB9, VXE2, VXE7, VXE9
			-	1	-	-	1	-----	HA2, HA2/A, HX26, HX26/A, LX2, LXE4, LXQ4, LXQ4/A, LXU, PKT2, PKT2/A, PKX2, PKX2/A, QAE6, QAE6/A, QAH2, QAH2/A, QE, QE/A, QHB4, QHB4/A, QHQ4, QKA4, QKA4/A, QMT2, QMT2/A, QNR2, QNR2/A, QXB7, QXB7/A, QXB9, QXE4, QXE4/A, QXE6, QXE8, QXQ4, QXQ4/A, QXU, QXU/A, SE, SE/A, SE1, SE2, SHQ4, SHQ4/A, SME0, SME0/A, SMX2, SXE4, SXE4/A, SXE8, SXQ4, SXQ4/A, VA2, VX16, VX16/A, VXB7, VXB9, VXE2, VXE2/A, VXE9
8	87533-ZC0-630	MARK, AIR CLEANER(ENGLISH)...	-	-	1	1	-	-----	EDE2, EDE2/A, EDN2, EDN2/A, EDS6, EDS6/A, EDT6, EDT6/A, VC2, VWC, VWC/A, VWE, VWE/A, VWS, VWS1, VWS1/A
9	87534-ZE1-841	LABEL, AIR CLEANER CAUTION...	1	-	-	-	-	-----	QDW9, QXC6, QXC9
10	87535-ZE1-841	MARK, AIR CLEANER SALES POINT	1	1	-	-	-	1009910	----- QDW9, QXC9
11	87539-898-620	MARK, EX. CAUTION (ENGLISH/FRENCH)	-	-	1	1	-	-----	QDW9, QXC4, QXC6, QXC9
12	87594-ZB4-A00	MARK, OIL CAUTION.....	-	-	1	1	-	-----	EDS6, EDS6/A, EDT6, EDT6/A, VC2, VWC, VWC/A, VWE, VWE/A, VWS1, VWS1/A
13	89216-Z0T-800	WRENCH, SPARK PLUG.....	1	1	1	1	1	-----	EDE2, EDE2/A, EDN2, EDN2/A, HA2, HA2/A, PKT2, PKT2/A, PKX2, PKX2/A, QA2, QA2/A, QA26, QAE2, QAE2/A, QAE6, QAE6/A, QAH2, QAH2/A, QAP2, QAP2/A, QNB2, QNE2, QNE2/A, QWC, QWC/A, QZA2, QZAV, QZN2, SMX2, VA2, QE, QE/A, QHB4, QHB4/A, QKA4, QKA4/A, QNR2, QNR2/A, QNR6, SE, SE/A, SE1, VDE2, VW12
	89216-ZB4-000	WRENCH, PLUG.....	-	-	1	1	-	-----	EDS6, EDS6/A, EDT6, EDT6/A, VC2, VWS
14	87516-Z4H-810	MARK, OPERATOR CAUTION (PICTOGRAPH)(MADE IN THAI)	(1)	-	(1)	-	-	-----	
15	87516-Z4H-801	MARK, OPERATOR CAUTION(FRENCH) (MADE IN THAI)	1	-	1	-	-	1007579	-----
	87516-Z4H-010	MARK, OPERATOR CAUTION (ENGLISH)(MADE IN THAI)	1	-	1	-	-	1007579	----- LX2, LXE4, LXU, QA2, QAE2, QAG, QAP2, QDW9, QE, QHB4, QHQ4, QKA4, QNE2, QXB7, QXB9, QXC4, QXC9, QXE4, QXQ4, QXU, SE, SHQ4, SME0, SXQ4, VWC, VWE, VXB7, VXB9, VXE7, VXE9



E-28

LABEL/TOOL

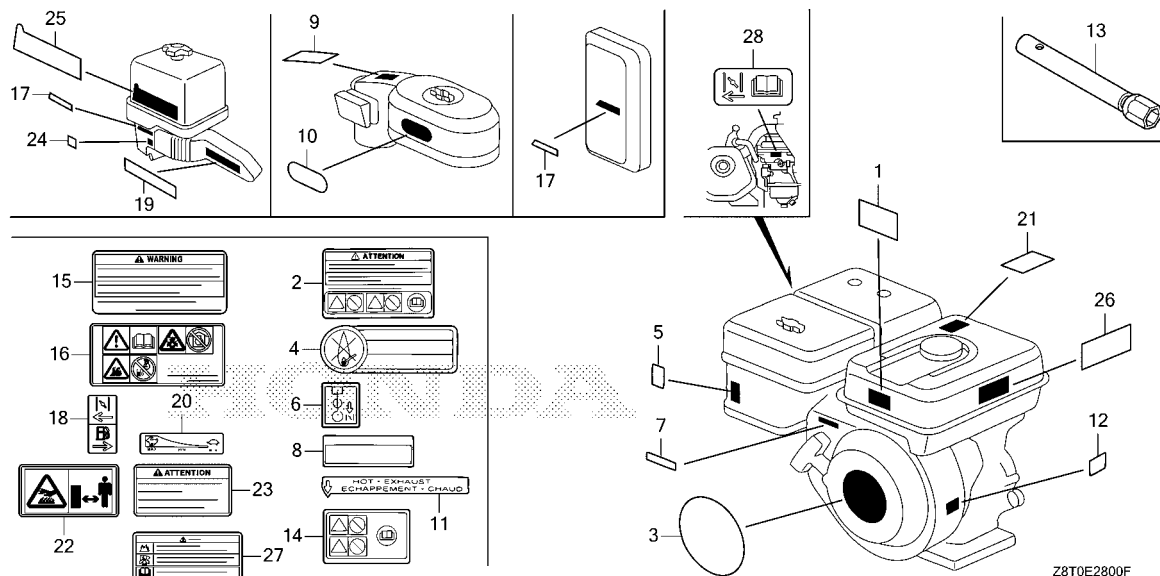

Ref. No.	Part No.	Description	Reqd. QTY					Serial No.	Parts catalogue code
			GX 340 UT1	GX 340 UT2	GX 340 RT1	GX 340 RT2	GX 340 UT2X		
15)	87516-Z4H-801	MARK, OPERATOR CAUTION(FRENCH) (MADE IN THAI)	-	1	-	1	1	-----	EDE2, EDE2/A, EDN2, EDN2/A, EDS6, EDS6/A, EDT6, EDT6/A, HA2, HA2/A, HX26, HX26/A, LX2, LXE4, LXQ4, LXQ4/A, LXU, PKT2, PKT2/A, PKX2, PKX2/A, QA2, QA2/A, QAE2, QAE2/A, QAE6, QAE6/A, QAG, QAH2, QAH2/A, QAP2, QAP2/A, QDW9, QE, QE/A, QHB4, QHB4/A, QHQ4, QKA4, QKA4/A, QMT2, QMT2/A, QNB2, QNE2, QNE2/A, QNR2, QNR2/A, QWC, QWC/A, QXB7, QXB7/A, QXB9, QXC9, QXE4, QXE4/A, QXE6, QXE8, QXQ4, QXQ4/A, QXU, QXU/A, QZA2, QZAV, QZN2, QZX4, SE, SE/A, SE1, SE2, SHQ4, SHQ4/A, SME0, SME0/A, SMX2, SXE4, SXE4/A, SXE8, SXQ4, SXQ4/A, VA2, VDE2, VVC, VVC/A, VVE, VVE/A, VWE2, VWE2/A, VVS, VVS1, VX16, VX16/A, VX8, VX8/A, VXB7, VXB9, VXE2, VXE2/A, VXE8, VXE8/A, VXE9
	87516-Z4H-010	MARK, OPERATOR CAUTION (ENGLISH)(MADE IN THAI)	-	1	-	1	1	-----	EDS6/A, EDT6/A, LXE4, LXU, QA2, QA2/A, QAE2, QAE2/A, QAG, QAP2, QAP2/A, QDW9, QE, QE/A, QHB4, QHB4/A, QHQ4, QKA4, QKA4/A, QNE2, QNE2/A, QWC, QWC/A, QXB7, QXB7/A, QXB9, QXC9, QXE4, QXE4/A, QXQ4, QXQ4/A, QXU, QXU/A, QZA2, QZAV, QZN2, QZX4, SE, SE/A, SE1, SE2, SHQ4, SHQ4/A, SME0, SME0/A, SXE4, SXE4/A, SXQ4, SXQ4/A, VVC, VVC/A, VVE, VVE/A, VVS, VVS1, VXB7, VXB9, VXE9
			-	-	-	1	1062751	-----	EDS6, EDT6



E-28

LABEL/TOOL

Ref. No.	Part No.	Description	Reqd. QTY					Serial No.	Parts catalogue code
			GX 340 UT1	GX 340 UT2	GX 340 RT1	GX 340 RT2	GX 340 UT2X		
16	87519-24H-000	MARK, OPERATOR CAUTION (PICTOGRAPH)	1	-	1	-	-	1007579	HA2, HX26, LX2, LXE8, LXQ4, LXU, PKT2, QA2, QA26, QAE2, QAE6, QAG QAH2, QAP2, QNB2, QNE2, QNR2, QNR6, QXC6, QXC9, QXE6, QXE8, SXE8 VA2, VAD2, VC2, VDE2, VW12, WVC, VWE, VWE2, VX16, VX8, VXE2, VXE8 EDE2, EDE2/A, EDN2, EDN2/A, EDS6, EDS6/A, EDT6, EDT6/A, HA2, HA2/A HX26, HX26/A, LX2, LXQ4, LXQ4/A, PKT2, PKT2/A, PKX2, PKX2/A, QA2 QA2/A, QAE2, QAE2/A, QAE6, QAE6/A, QAG, QAH2, QAH2/A, QAP2, QAP2/A QDW9, QMT2, QMT2/A, QNB2, QNE2, QNE2/A, QNR2, QNR2/A, QWC, QWC/A QXC9, QXE6, QXE8, QZA2, QZAV, QZN2, SMX2, SXE8, VA2, VDE2, VWC VWC/A, VWE, VWE/A, VWE2, VWE2/A, VWS, VWS1, VX16, VX16/A, VX8 VX8/A, VXE2, VXE2/A, VXE8, VXE8/A
17	87539-20J-000	MARK, EX. CAUTION(ENGLISH) ...	1	-	1	-	-	1007579	HA2, HX26, LX2, LXE8, LXQ4, PKT2, QA2, QA26, QAE2, QAE6, QAG, QAH2 QAP2, QDW9, QNB2, QNE2, QNR2, QNR6, QXC6, QXC9, QXE6, QXE8, SXE8 VA2, VAD2, VDE2, VW12, VWE2, VX16, VX8, VXE2, VXE8
18	87528-22E-800 87539-20J-000	MARK, CHOKE MARK, EX. CAUTION(ENGLISH) ...	- 1	1	-	-	-	- 1007579	QZA2, QZAV, QZN2, QZX4 LXE4, LXU, QE, QHB4, QHQ4, QKA4, QXB7, QXB9, QXC4, QXE4, QXQ4, QXU SE, SHQ4, SME0, SXE4, SXQ4, VXB7, VXB9, VXE7, VXE9
	87528-25T-000	MARK, CHOKE	- 1	1	-	-	-	- 2023400	QA2, QAE2, QAG, QAP2, QDW9, QKA4, QNE2, QWC, QXC9 QA2/A, QAE2/A, QAP2/A, QKA4/A, QNE2/A, QWC/A
	87528-24M-000	-	1	-	-	-	2023401	QA2/A, QAE2/A, QAP2/A, QKA4/A, QNE2/A, QWC/A
19	87539-20J-800	MARK, EX. CAUTION(PICTOGRAPH)	1	-	-	-	-	1008294	QA2, QAE2, QAP2, QKA4, QNE2, QWC HA2, HX26, LX2, LXE8, LXQ4, PKT2, QA2, QA26, QAE2, QAE6, QAG, QAH2 QAP2, QDW9, QNE2, QNR2, QNR6, QXC6, QXC9, QXE6, QXE8, SXE8, VA2 VX16, VX8, VXE2, VXE8
	87531-25T-W00	MARK(HONDA)	-	1	-	-	-	-	QZA2, QZAV, QZN2, QZX4
20	87532-ZH7-000	MARK, THROTTLE INDICATION	-	1	-	-	1	-	QA2, QA2/A, QAE2, QAE2/A, QAG, QAP2, QAP2/A, QDW9, QNE2, QNE2/A QWC, QWC/A, QXC9
21	87539-20J-000	MARK, EX. CAUTION(ENGLISH) ...	-	1	-	1	1	-	HA2, HA2/A, HX26, HX26/A, LX2, LXE4, LXQ4, LXQ4/A, LXU, PKT2 PKT2/A, PKX2, PKX2/A, QA2, QA2/A, QAE2, QAE2/A, QAE6, QAE6/A, QAG QAH2, QAH2/A, QAP2, QAP2/A, QDW9, QE, QE/A, QHB4, QHB4/A, QHQ4 QKA4, QKA4/A, QMT2, QMT2/A, QNB2, QNE2, QNE2/A, QNR2, QNR2/A, QWC QWC/A, QXB7, QXB7/A, QXB9, QXC9, QXE4, QXE4/A, QXE6, QXE8, QXQ4 QXQ4/A, QXU, QXU/A, QZA2, QZAV, QZN2, QZX4, SE, SE/A, SE1, SE2, SHQ4 SHQ4/A, SME0, SME0/A, SMX2, SXE4, SXE4/A, SXE8, SXQ4, SXQ4/A, VA2 VDE2, VWE2, VWE2/A, VX16, VX16/A, VX8, VX8/A, VXB7, VXB9, VXE2 VXE2/A, VXE8, VXE8/A, VXE9
22	87539-20J-800	MARK, EX. CAUTION(PICTOGRAPH)	-	1	-	-	1	-	HA2, HA2/A, HX26, HX26/A, LX2, LXQ4, LXQ4/A, PKT2, PKT2/A, PKX2 PKX2/A, QA2, QA2/A, QAE2, QAE2/A, QAE6, QAE6/A, QAG, QAH2, QAH2/A QAP2, QAP2/A, QDW9, QMT2, QMT2/A, QNE2, QNE2/A, QNR2, QNR2/A, QWC QWC/A, QXC9, QXE6, QXE8, QZA2, QZAV, QZN2, SMX2, SXE8, VA2, VX16 VX16/A, VX8, VX8/A, VXE2, VXE2/A, VXE8, VXE8/A
23	87539-20J-810	MARK, EX. CAUTION(FRENCH)	1	-	1	-	-	1007579	HA2, HX26, LX2, LXE4, LXE8, LXQ4, LXU, PKT2, QA2, QA26, QAE2, QAE6 QAG, QAH2, QAP2, QDW9, QE, QHB4, QHQ4, QKA4, QNB2, QNE2, QNR2, QNR6 QXB7, QXB9, QXC4, QXC6, QXC9, QXE4, QXE6, QXE8, QXQ4, QXU, SE, SHQ4 SME0, SXE4, SXE8, SXQ4, VA2, VAD2, VDE2, VW12, VWE2, VX16, VX8, VXB7, VXB9, VXE2, VXE7, VXE8, VXE9
			-	1	-	1	1	-	HA2, HA2/A, HX26, HX26/A, LX2, LXE4, LXQ4, LXQ4/A, LXU, PKT2 PKT2/A, PKX2, PKX2/A, QA2, QA2/A, QAE2, QAE2/A, QAE6, QAE6/A, QAG QAH2, QAH2/A, QAP2, QAP2/A, QDW9, QE, QE/A, QHB4, QHB4/A, QHQ4 QKA4, QKA4/A, QMT2, QMT2/A, QNB2, QNE2, QNE2/A, QNR2, QNR2/A, QWC QWC/A, QXB7, QXB7/A, QXB9, QXC9, QXE4, QXE4/A, QXE6, QXE8, QXQ4 QXQ4/A, QXU, QXU/A, QZA2, QZAV, QZN2, QZX4, SE, SE/A, SE1, SE2, SHQ4 SHQ4/A, SME0, SME0/A, SMX2, SXE4, SXE4/A, SXE8, SXQ4, SXQ4/A, VA2 VDE2, VWE2, VWE2/A, VX16, VX16/A, VX8, VX8/A, VXB7, VXB9, VXE2 VXE2/A, VXE8, VXE8/A, VXE9
24	87565-25T-W00	MARK, FUEL	-	1	-	-	-	-	QZA2, QZAV, QZN2, QZX4
25	87602-Z8T-W00	MARK, SALES POINT	-	1	-	-	-	-	QZA2, QZAV, QZN2, QZX4



E-28

LABEL/TOOL

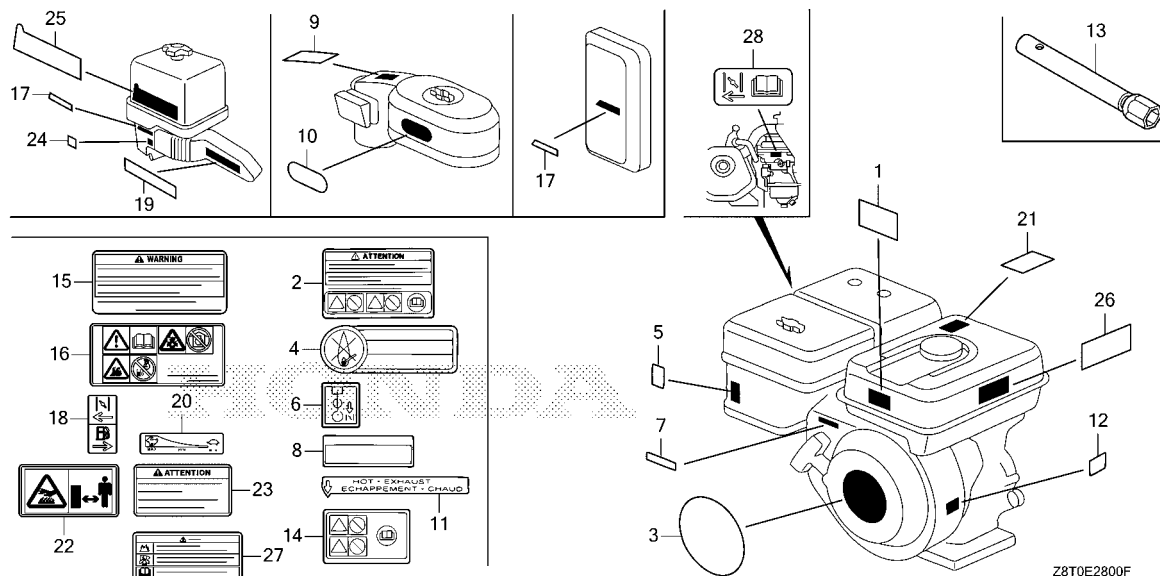

Ref. No.	Part No.	Description	Reqd. QTY					Serial No.	Parts catalogue code
			GX 340 UT1	GX 340 UT2	GX 340 RT1	GX 340 RT2	GX 340 UT2X		
26	87516-Z4H-010	MARK, OPERATOR CAUTION (ENGLISH)(MADE IN THAI)	-	1	-	1	1	-----	EDE2, EDE2/A, EDN2, EDN2/A, HA2, HA2/A, HX26, HX26/A, LX2, LXQ4, LXQ4/A, PKT2, PKT2/A, PKX2, PKX2/A, QAE6, QAE6/A, QAH2, QAH2/A, QMT2, QMT2/A, QNB2, QNR2, QNR2/A, QXE6, QXE8, SMX2, SXE8, VA2, VDE2, VWE2, VWE2/A, VX16, VX16/A, VX8, VX8/A, VXE2, VXE2/A, VXE8, VXE8/A
	87519-Z4H-000	MARK, OPERATOR CAUTION (PICTOGRAPH)	-	1	-	-	1	-----	LXE4, LXU, QE, QE/A, QHB4, QHB4/A, QHQ4, QKA4, QKA4/A, QXB7, QXB7/A, QXB9, QXE4, QXE4/A, QXQ4, QXQ4/A, QXU, QXU/A, QZX4, SE, SE/A, SE1, SE2, SHQ4, SHQ4/A, SME0, SME0/A, SXE4, SXE4/A, SXQ4, SXQ4/A, VXB7, VXB9, VXE9
	87516-Z4H-010	MARK, OPERATOR CAUTION (ENGLISH)(MADE IN THAI)	-	-	-	-	1	-----	1062750 EDS6, EDT6
27	87516-ZK6-800	MARK, OPERATOR CAUTION (CHINESE)	-	1	-	1	-	-----	EDS6/A, EDT6/A, PKT2/A, PKX2/A, QA2/A, QMT2/A, QNR2/A
			-	1	-	1	-	1062751	EDS6, EDT6, PKT2
			-	1	-	-	-	1036529	PKX2, QA2, QMT2, QNR2
			-	-	-	-	1	-----	PKT2, PKX2, QA2, QMT2, QNR2
28	87528-Z5T-W00	MARK, CHOKE	-	1	-	-	-	-----	QZA2, QZAV, QZN2, QZX4



E-40

OTHER PARTS(COMBINATION SWITCH)

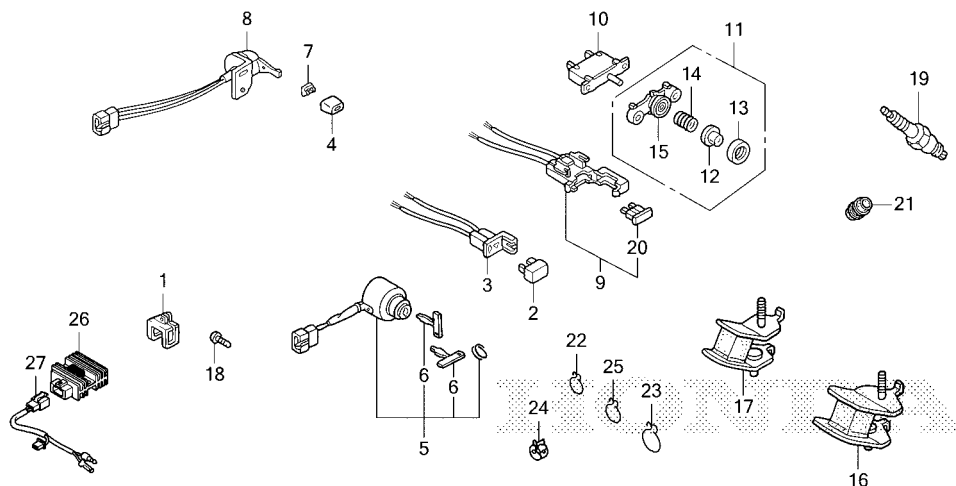

Z8T0E4000C

Ref. No. L.O.N. (Relative ref. Number) Description F.R.T.

Ref. No.	Part No.	Description	Reqd. QTY					Serial No.	Parts catalogue code
			GX 340 UT1	GX 340 UT2	GX 340 RT1	GX 340 RT2	GX 340 UT2X		
1	30561-ZB4-000	CLIP, WIRE.....	-	-	-	1	-	EDS6,EDS6/A,EDT6,EDT6/A	
2	31700-124-008	RECTIFIER ASSY., SILICON (SHINDENGEN)	-	-	-	1	-	EDS6,EDS6/A,VWE,VWE/A	
3	32130-ZE1-000	COUPLER COMP.....	-	-	-	1	-	EDS6,EDS6/A	
4	32343-892-003	KNOB, COCK LEVER.....	-	-	-	1	-	EDT6,EDT6/A	
5	35100-ZB4-023	SWITCH ASSY., COMBINATION (HONDA LOCK)	-	-	-	1	-	EDS6,EDS6/A	
6	35111-880-013	KEY COMP.(HONDA LOCK).....	-	-	-	2	-	EDS6,EDS6/A	
7	36106-892-003	BUSH, CONTROL KNOB.....	-	-	-	1	-	EDT6,EDT6/A	
8	36110-ZB4-702	SWITCH ASSY., ENGINE KILL....	-	-	-	1	-	EDT6,EDT6/A	
9	38220-ZE1-000	CASE COMP., FUSE.....	-	-	-	1	-	EDS6,EDS6/A	
10	38240-VA3-900	PROTECTOR, CIRCUIT(1.0A).....	-	-	-	1	-	EDS6,EDS6/A	
11	38250-898-000	LENS ASSY., PROTECTOR.....	-	-	-	1	-	EDS6,EDS6/A	
12	38251-898-000	LENS.....	-	-	-	1	-	EDS6,EDS6/A	
13	38252-898-000	CAP, LENS.....	-	-	-	1	-	EDS6,EDS6/A	
14	38253-898-000	SPRING, COIL.....	-	-	-	1	-	EDS6,EDS6/A	
15	38254-898-000	HOLDER, LENS.....	-	-	-	1	-	EDS6,EDS6/A	
16	68325-899-000	RUBBER, BOTTOM.....	-	-	-	2	-	VWS,VWS1,VWS1/A	
17	68325-ZC2-000	RUBBER, BOTTOM.....	-	-	-	2	-	VWS,VWS1,VWS1/A	
18	90101-692-000	SCREW, GLOVE BOX.....	-	-	-	1	-	EDS6,EDS6/A,EDT6,EDT6/A	
19	98079-55876	PLUG, SPARK(BPR5E5)(NGK).....	-	-	-	1	-	VWS	
20	98200-30500	FUSE, BLADE(5A).....	-	-	-	1	-	EDS6,EDS6/A	
21	90854-ZB3-000	RUBBER, FUEL(9X15X20).....	-	-	-	3	-	VWS1/A	
22	95002-02080	CLIP, TUBE(B8).....	-	-	-	6	-	VWS1/A	
23	95002-02130	CLIP, TUBE(B12.5).....	-	-	-	1	-	VWS1/A	



E-40

OTHER PARTS(COMBINATION SWITCH)

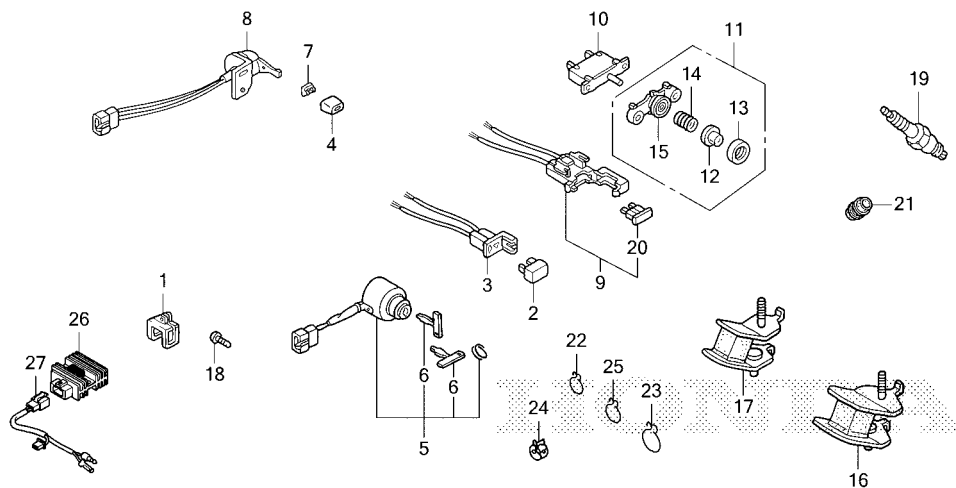

Z8T0E4000C

Ref. No.	Part No.	Description	Reqd. QTY					Serial No.	Parts catalogue code
			GX 340 UT1	GX 340 UT2	GX 340 RT1	GX 340 RT2	GX 340 UT2X		
24	95002-40800-08	CLAMP, TUBE(D8).....	-	-	-	1	-	-----	VWS1/A
25	95002-50000	CLIP, TUBE(C9).....	-	-	-	1	-	-----	VWS1/A
26	31600-ZE2-861	RECTIFIER ASSY., REGULATOR (10A)	-	1	-	-	1	-----	SE2
27	32110-ZE2-860	HARNESS ASSY., SUB WIRE.....	-	1	-	-	1	-----	SE2

E-40-1

OTHER PARTS(FUEL COCK)

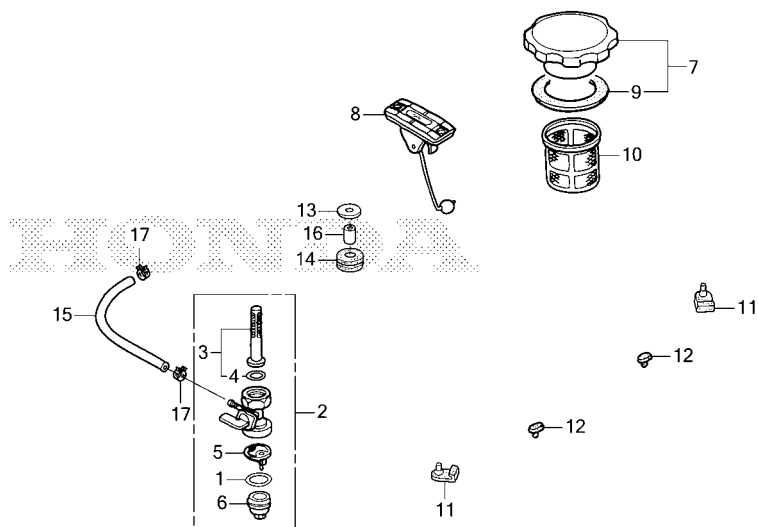

Z8T0E4001A

Ref. L.O.N. (Relative ref. Number) F.R.T.
No. Description

Ref. No.	Part No.	Description	Reqd. QTY					Serial No.	Parts catalogue code
			GX 340 UT1	GX 340 UT2	GX 340 RT1	GX 340 RT2	GX 340 UT2X		
1	16173-001-004	O-RING	-	-	-	1	-	EDE2, EDE2/A, EDN2, EDN2/A, EDS6, EDS6/A, EDT6, EDT6/A, VWS	
2	16950-ZB4-015	COCK ASSY., FUEL	-	-	-	1	-	EDE2, EDE2/A, EDN2, EDN2/A, EDS6, EDS6/A, EDT6, EDT6/A, VWS	
3	16952-ZB4-005	SCREEN SET, FUEL STRAINER	-	-	-	1	-	EDE2, EDE2/A, EDN2, EDN2/A, EDS6, EDS6/A, EDT6, EDT6/A, VWS	
4	16958-397-771	O-RING, 9.0X1.3	-	-	-	1	-	EDE2, EDE2/A, EDN2, EDN2/A, EDS6, EDS6/A, EDT6, EDT6/A, VWS	
5	16959-471-831	FILTER, CUP	-	-	-	1	-	EDE2, EDE2/A, EDN2, EDN2/A, EDS6, EDS6/A, EDT6, EDT6/A, VWS	
6	16967-GA6-671	CUP, FUEL STRAINER	-	-	-	1	-	EDE2, EDE2/A, EDN2, EDN2/A, EDS6, EDS6/A, EDT6, EDT6/A, VWS	
7	17620-899-013	CAP COMP., FUEL FILLER	-	-	-	1	1030502	VWS	
	17620-899-800		-	-	-	1	1030503	VWS	
8	17630-Z8V-003	METER ASSY., FUEL	-	-	-	1	-	VWS	
9	17631-899-000	PACKING, FUEL FILLER CAP	-	-	-	1	-	VWS	
10	17670-899-000	FILTER COMP., FUEL	-	-	-	1	-	VWS	
11	50319-ZB2-000	RUBBER, TANK MOUNTING	-	-	-	2	-	EDS6, EDS6/A, EDT6, EDT6/A	
12	76122-952-000	STOPPER, DISCHARGE GUARD	-	-	-	4	-	VWS, VWS1, VWS1/A	
13	90503-898-000	WASHER, TANK CUSHION	-	-	-	4	-	VWS	
14	90851-898-000	RUBBER, TANK CUSHION	-	-	-	4	-	VWS	
15	91424-Z5L-812	TUBE, FUEL, 4.5X165(FKM)	-	-	-	1	-	EDS6, EDT6	
	91424-Z5M-812	TUBE, FUEL, 4.5X210(FKM)	-	-	-	1	-	EDN2	
	91424-Z5R-802	TUBE, FUEL, 4.5X260(FKM)	-	-	-	1	-	1024985 1093370	
	91424-Z5L-812	TUBE, FUEL, 4.5X165(FKM)	-	-	-	1	-	2017998	
	91424-ZBH-831	TUBE, FUEL, 4.2X260(FKM)	-	-	-	1	-	2018031	
	91424-Z5K-003	TUBE, FUEL, 4.5X210(FKM)	-	-	-	1	1024986	EDE2/A, EDN2/A EDN2	
	91424-ZBH-831	TUBE, FUEL, 4.2X260(FKM)	-	-	-	1	1093371	1093370	
	91424-Z5L-813	TUBE, FUEL, 4.5X165(FKM)	-	-	-	1	2017999	EDE2, EDN2	
	91424-ZBH-832	TUBE, FUEL, 4.2X260(FKM)	-	-	-	1	2018032	EDS6/A, EDT6/A EDE2/A, EDN2/A	
16	91551-898-000	COLLAR, TANK CUSHION	-	-	-	4	-	VWS	
17	95002-40800-08	CLAMP, TUBE(D8)	-	-	-	2	-	EDE2, EDE2/A, EDN2, EDN2/A, EDS6, EDS6/A, EDT6, EDT6/A	



E-40-2

OTHER PARTS(AIR CLEANER)

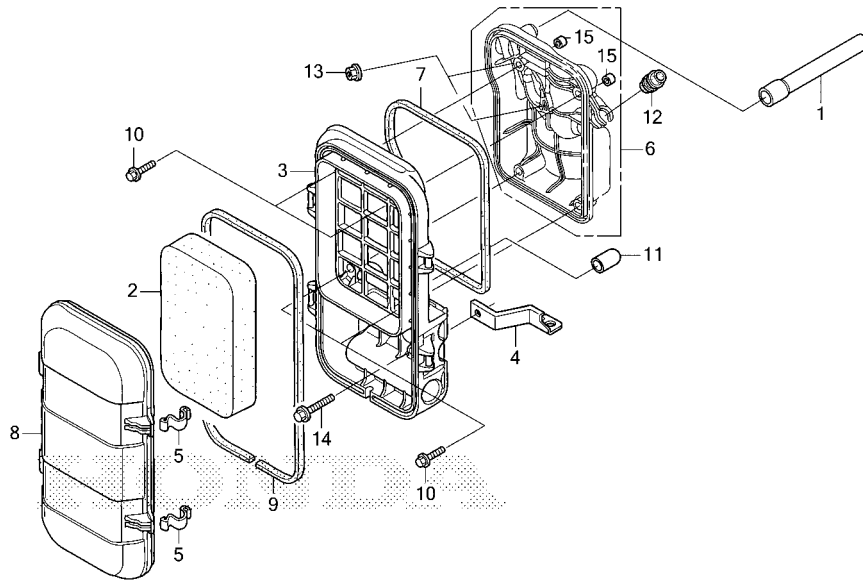

Z8T0E4002B

Ref. L.O.N. (Relative ref. Number) F.R.T.
No. Description

Ref. No.	Part No.	Description	Reqd. QTY					Serial No.	Parts catalogue code
			GX 340 UT1	GX 340 UT2	GX 340 RT1	GX 340 RT2	GX 340 UT2X		
1	15721-Z23-H60	TUBE, BREATHER	-	-	-	1	-	EDE2, EDE2/A, EDN2, EDN2/A, EDS6, EDS6/A, EDT6, EDT6/A, VWS	
2	17211-899-000	ELEMENT, AIR CLEANER	-	-	-	1	-	EDE2, EDE2/A, EDN2, EDN2/A, EDS6, EDS6/A, EDT6, EDT6/A, VWS	
3	17220-Z23-S30	CASE COMP., AIR CLEANER	-	-	-	1	-	EDE2, EDE2/A, EDN2, EDN2/A, EDS6, EDS6/A, EDT6, EDT6/A, VWS	
4	17222-Z23-H60	STAY, AIR CLEANER	-	-	-	1	-	EDE2, EDE2/A, EDN2, EDN2/A, EDS6, EDS6/A, EDT6, EDT6/A, VWS	
5	17223-Z23-000	SPRING, AIR CLEANER CASE LID	-	-	-	2	-	EDE2, EDE2/A, EDN2, EDN2/A, EDS6, EDS6/A, EDT6, EDT6/A, VWS	
6	17223-ZBH-000	BASE COMP., AIR CLEANER	-	-	-	1	-	EDE2/A, EDN2/A, EDS6/A, EDT6/A	
	17223-Z23-S30		-	-	-	1	1075630	EDE2, EDN2, EDS6, EDT6, VWS	
	17223-ZBH-000		-	-	-	1	1075631	EDE2, EDN2, EDS6, EDT6, VWS	
7	17229-Z23-H60	SEAL, AIR CLEANER CASE	-	-	-	1	-	EDE2, EDE2/A, EDN2, EDN2/A, EDS6, EDS6/A, EDT6, EDT6/A, VWS	
8	17231-ZBH-000	COVER, AIR CLEANER	-	-	-	1	-	EDE2, EDE2/A, EDN2, EDN2/A, EDS6, EDS6/A, EDT6, EDT6/A, VWS	
9	17233-Z23-H60	SEAL, AIR CLEANER COVER	-	-	-	1	-	EDE2, EDE2/A, EDN2, EDN2/A, EDS6, EDS6/A, EDT6, EDT6/A, VWS	
10	90005-ZM3-000	BOLT, FLANGE, 5X18	-	-	-	4	-	EDE2, EDE2/A, EDN2, EDN2/A, EDS6, EDS6/A, EDT6, EDT6/A, VWS	
11	90802-Z6L-000	CAP, SEALING	-	-	-	1	-	EDE2, EDE2/A, EDN2, EDN2/A, EDS6, EDS6/A, EDT6, EDT6/A, VWS	
12	90854-ZB3-000	RUBBER, FUEL(9X15X20)	-	-	-	1	-	EDE2, EDE2/A, EDN2, EDN2/A, EDS6, EDS6/A, EDT6, EDT6/A	
13	94050-06000	NUT, FLANGE, 6MM	-	-	-	2	-	EDE2, EDE2/A, EDN2, EDN2/A, EDS6, EDS6/A, EDT6, EDT6/A, VWS	
14	95701-06032-08	BOLT, FLANGE, 6X32	-	-	-	1	-	EDE2, EDE2/A, EDN2, EDN2/A, EDS6, EDS6/A, EDT6, EDT6/A, VWS	
15	17238-ZG9-M00	COLLAR, AIR CLEANER	-	-	-	2	-	EDE2, EDE2/A, EDN2, EDN2/A, EDS6, EDS6/A, EDT6, EDT6/A, VWS	

E-40-3

OTHER PARTS(MUFFLER)

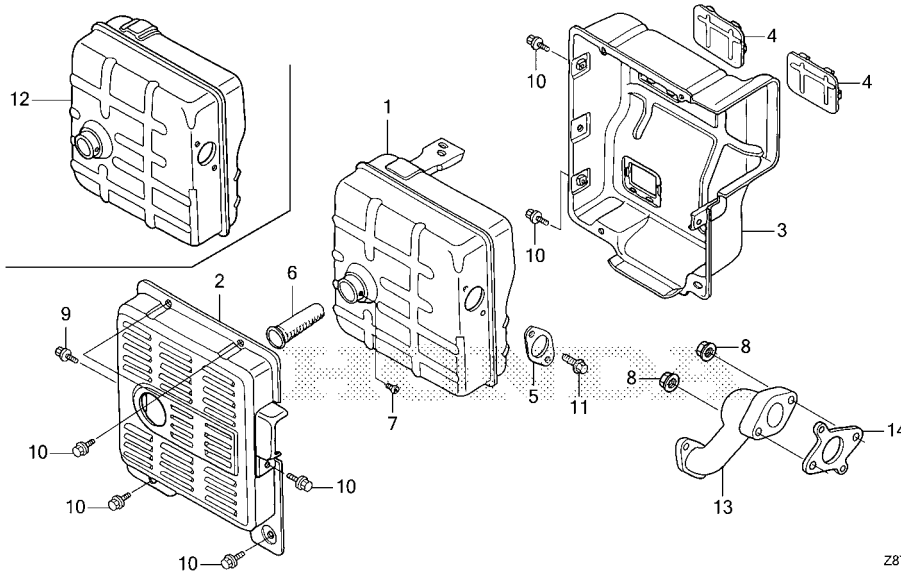

Ref. L.O.N. (Relative ref. Number) F.R.T.
No. Description

Ref. No.	Part No.	Description	Reqd. QTY					Serial No.	Parts catalogue code
			GX 340 UT1	GX 340 UT2	GX 340 RT1	GX 340 RT2	GX 340 UT2X		
1	18310-ZE2-U91	MUFFLER COMP.(DENYO).....	-	-	-	1	-	EDE2, EDN2	
	18310-Z1C-842	MUFFLER COMP.	-	-	-	1	-	EDS6, EDS6/A, EDT6, EDT6/A	
	18310-ZE2-U91	MUFFLER COMP.(DENYO).....	-	-	-	1	2018475	EDE2/A, EDN2/A	
	18310-ZE2-U92	-	-	-	1	-	EDE2/A, EDN2/A	
2	18320-ZC2-000	PROTECTOR, MUFFLER OUTER.....	-	-	-	1	-	EDE2, EDE2/A, EDN2, EDN2/A, EDS6, EDS6/A, EDT6, EDT6/A, VWS1/A	
3	18325-ZB4-000	PROTECTOR, MUFFLER INNER.....	-	-	-	1	-	EDE2, EDE2/A, EDN2, EDN2/A, EDS6, EDS6/A, EDT6, EDT6/A, VWS1/A	
4	18329-ZB4-000	SEAL, MUFFLER PROTECTOR.....	-	-	-	2	-	EDE2, EDE2/A, EDN2, EDN2/A, EDS6, EDS6/A, EDT6, EDT6/A, VWS1/A	
5	18333-ZB4-801	GASKET, EX. PIPE.....	-	-	-	1	-	EDE2, EDE2/A, EDN2, EDN2/A, EDS6, EDS6/A, EDT6, EDT6/A, VWS, VWS1/A	
6	18355-ZB4-630	ARRESTER, SPARK.....	-	-	-	1	-	EDE2, EDE2/A, EDN2, EDN2/A, EDS6, EDS6/A, EDT6, EDT6/A, VWS1/A	
7	90002-ZE2-U91	SCREW, TAPPING, 4X8.....	-	-	-	1	-	EDE2, EDE2/A, EDN2, EDN2/A, EDS6/A, EDT6/A	
	90002-Z0T-800	-	-	-	1	-	VWS1/A	
	90002-ZE2-U91	-	-	-	1	1054331	EDS6, EDT6	
8	94050-08000	NUT, FLANGE, 8MM.....	-	-	-	2	-	EDS6, EDT6	
			-	-	-	2	-	VWC, VWC/A, VWE, VWE/A, VWE2/A, VWS, VWS1, VWS1/A	
			-	-	-	2	1104462	VWE2	
9	95701-06010-00	BOLT, FLANGE, 6X10.....	-	-	-	1	-	EDS6, EDS6/A, EDT6, EDT6/A	
10	95701-06012-00	BOLT, FLANGE, 6X12.....	-	-	-	7	-	EDS6, EDS6/A, EDT6, EDT6/A	
11	95701-08020-00	BOLT, FLANGE, 8X20.....	-	-	-	2	-	EDE2, EDE2/A, EDN2, EDN2/A, EDS6, EDS6/A, EDT6, EDT6/A, VWS, VWS1/A	
12	18310-Z8W-V62	MUFFLER COMP.(TSURUMI).....	-	-	-	1	-	VWS1, VWS1/A	
13	18330-ZE3-710	PIPE, EX.	-	-	-	1	-	VWS1, VWS1/A	
14	18333-ZF6-W01	GASKET, EX. PIPE.....	-	-	-	1	-	VWC, VWC/A, VWE, VWE/A, VWE2/A, VWS, VWS1, VWS1/A	
			-	-	-	1	1104462	VWE2	



EOP-1

GASKET KIT

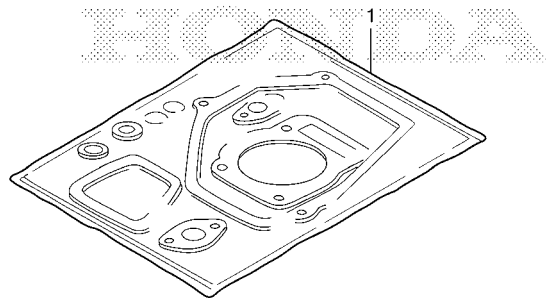

Z8T0X0100

Ref. No.	L.O.N.	(Relative ref. Number) Description	F.R.T.
----------	--------	---------------------------------------	--------

Ref. No.	Part No.	Description	Reqd. QTY					Serial No.	Parts catalogue code
			GX 340 UT1	GX 340 UT2	GX 340 RT1	GX 340 RT2	GX 340 UT2X		
1	06111-ZK3-U61	GASKET KIT.....	(1)	-	-	-	-	----- QAH2	
	06111-ZK3-W01	-	-	(1)	-	-	----- VC2	

2

EOP-2

MUFFLER COVER

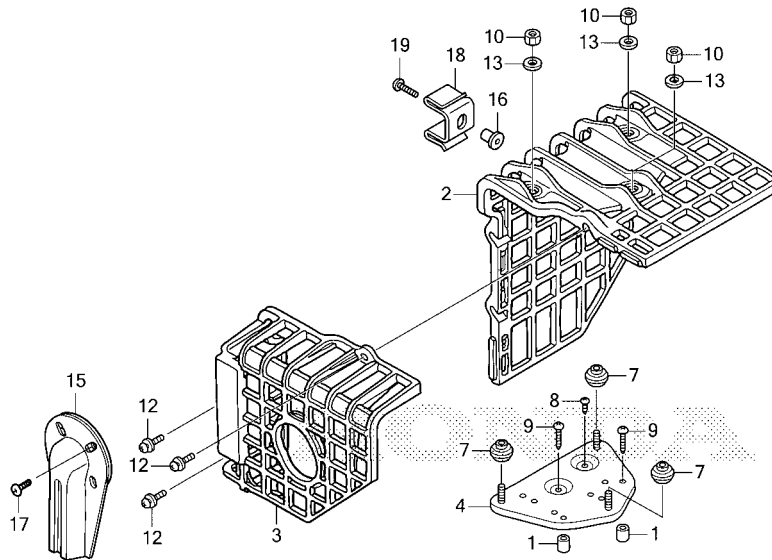

Z8T0X0200C

Ref. L.O.N. (Relative ref. Number) F.R.T.
No. Description

Ref. No.	Part No.	Description	Reqd. QTY					Serial No.	Parts catalogue code
			GX 340 UT1	GX 340 UT2	GX 340 RT1	GX 340 RT2	GX 340 UT2X		
1	17233-896-701	COLLAR, AIR CLEANER CASE.....	(2)	(2)	-	-	(2)	LXE4, LXQ4, LXQ4/A, QE, QE/A, QHB4, QHB4/A, QHQ4, QKA4, QKA4/A, QXB7, QXB7/A, QXB9, QXC4, QXE4, QXE4/A, QXQ4, QXQ4/A, QZX4, SE SE/A, SE1, SE2, SHQ4, SHQ4/A, SME0, SME0/A, SXE4, SXE4/A, SXQ4 SXQ4/A, VXB7, VXB9, VXE7, VXE9	
2	18433-Z5T-000	COVER COMP., MUFFLER.....	(1)	(1)	-	-	(1)	LXE4, LXQ4, LXQ4/A, QE, QE/A, QHB4, QHB4/A, QHQ4, QKA4, QKA4/A, QXB7, QXB7/A, QXB9, QXC4, QXE4, QXE4/A, QXQ4, QXQ4/A, QZX4, SE SE/A, SE1, SE2, SHQ4, SHQ4/A, SME0, SME0/A, SXE4, SXE4/A, SXQ4 SXQ4/A, VXB7, VXB9, VXE7, VXE9	
3	18434-Z5T-000	COVER COMP., RR. MUFFLER.....	(1)	(1)	-	-	(2)	LXE4, LXQ4, LXQ4/A, QE, QE/A, QHB4, QHB4/A, QHQ4, QKA4, QKA4/A, QXB7, QXB7/A, QXB9, QXC4, QXE4, QXE4/A, QXQ4, QXQ4/A, QZX4, SE SE/A, SE1, SE2, SHQ4, SHQ4/A, SME0, SME0/A, SXE4, SXE4/A, SXQ4 SXQ4/A, VXB7, VXB9, VXE7, VXE9	
4	18436-ZH8-W41	BASE COMP., MUFFLER COVER.....	(1)	(1)	-	-	(1)	LXE4, LXQ4, LXQ4/A, QE, QE/A, QHB4, QHB4/A, QHQ4, QKA4, QKA4/A, QXB7, QXB7/A, QXB9, QXC4, QXE4, QXE4/A, QXQ4, QXQ4/A, QZX4, SE SE/A, SE1, SE2, SHQ4, SHQ4/A, SME0, SME0/A, SXE4, SXE4/A, SXQ4 SXQ4/A, VXB7, VXB9, VXE7, VXE9	
7	18466-ZH8-W40	SPACER, MUFFLER COVER.....	(3)	(3)	-	-	(3)	LXE4, LXQ4, LXQ4/A, QE, QE/A, QHB4, QHB4/A, QHQ4, QKA4, QKA4/A, QXB7, QXB7/A, QXB9, QXC4, QXE4, QXE4/A, QXQ4, QXQ4/A, QZX4, SE SE/A, SE1, SE2, SHQ4, SHQ4/A, SME0, SME0/A, SXE4, SXE4/A, SXQ4 SXQ4/A, VXB7, VXB9, VXE7, VXE9	
8	90050-ZE1-000	SCREW, TAPPING, 5X8.....	(1)	(1)	-	-	(1)	LXE4, LXQ4, LXQ4/A, QE, QE/A, QHB4, QHB4/A, QHQ4, QKA4, QKA4/A, QXB7, QXB7/A, QXB9, QXC4, QXE4, QXE4/A, QXQ4, QXQ4/A, QZX4, SE SE/A, SE1, SE2, SHQ4, SHQ4/A, SME0, SME0/A, SXE4, SXE4/A, SXQ4 SXQ4/A, VXB7, VXB9, VXE7, VXE9	
9	90050-ZH8-W40	SCREW, TAPPING, 5X25.....	(2)	(2)	-	-	(2)	LXE4, LXQ4, LXQ4/A, QE, QE/A, QHB4, QHB4/A, QHQ4, QKA4, QKA4/A, QXB7, QXB7/A, QXB9, QXC4, QXE4, QXE4/A, QXQ4, QXQ4/A, QZX4, SE SE/A, SE1, SE2, SHQ4, SHQ4/A, SME0, SME0/A, SXE4, SXE4/A, SXQ4 SXQ4/A, VXB7, VXB9, VXE7, VXE9	



EOP-2

MUFFLER COVER

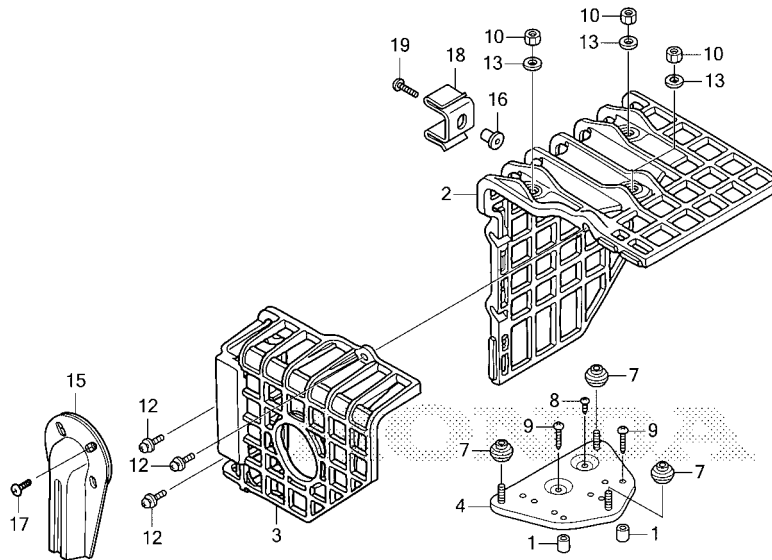

Z8T0X0200C

Ref. No.	Part No.	Description	Reqd. QTY					Serial No.	Parts catalogue code
			GX 340 UT1	GX 340 UT2	GX 340 RT1	GX 340 RT2	GX 340 UT2X		
10	90302-KF9-900	NUT, HEX., 5MM	(3)	(3)	-	-	(3)	LXE4, LXQ4, LXQ4/A, QE, QE/A, QHB4, QHB4/A, QHQ4, QKA4, QKA4/A, QXB7, QXB7/A, QXB9, QXC4, QXE4, QXE4/A, QXQ4, QXQ4/A, QZX4, SE SE/A, SE1, SE2, SHQ4, SHQ4/A, SME0, SME0/A, SXE4, SXE4/A, SXQ4 SXQ4/A, VXB7, VXB9, VXE7, VXE9	
12	93891-06020-07	SCREW-WASHER, 6X20	(3)	(3)	-	-	(3)	LXE4, LXQ4, LXQ4/A, QE, QE/A, QHB4, QHB4/A, QHQ4, QKA4, QKA4/A, QXB7, QXB7/A, QXB9, QXC4, QXE4, QXE4/A, QXQ4, QXQ4/A, QZX4, SE SE/A, SE1, SE2, SHQ4, SHQ4/A, SME0, SME0/A, SXE4, SXE4/A, SXQ4 SXQ4/A, VXB7, VXB9, VXE7, VXE9	
13	94103-05700	WASHER, PLAIN, 5MM	(3)	(3)	-	-	(3)	LXE4, LXQ4, LXQ4/A, QE, QE/A, QHB4, QHB4/A, QHQ4, QKA4, QKA4/A, QXB7, QXB7/A, QXB9, QXC4, QXE4, QXE4/A, QXQ4, QXQ4/A, QZX4, SE SE/A, SE1, SE2, SHQ4, SHQ4/A, SME0, SME0/A, SXE4, SXE4/A, SXQ4 SXQ4/A, VXB7, VXB9, VXE7, VXE9	
15	18430-ZF6-W50	DEFLECTOR COMP., MUFFLER	-	(1)	-	-	(1)	QE, QE/A, QHB4, QHB4/A, QKA4, QKA4/A, SE, SE/A, SE1	
16	19619-ZL8-300	COLLAR, FAN COVER	(1)	(1)	-	-	(1)	LXE4, LXQ4, LXQ4/A, QE, QE/A, QHB4, QHB4/A, QHQ4, QKA4, QKA4/A, QXB7, QXB7/A, QXB9, QXC4, QXE4, QXE4/A, QXQ4, QXQ4/A, QZX4, SE SE/A, SE1, SE2, SHQ4, SHQ4/A, SME0, SME0/A, SXE4, SXE4/A, SXQ4 SXQ4/A, VXB7, VXB9, VXE7, VXE9	
17	90055-ZE1-000	SCREW, TAPPING, 4X6	-	(2)	-	-	(2)	QE, QE/A, QHB4, QHB4/A, QKA4, QKA4/A, SE, SE/A, SE1	
18	18437-Z5T-000	STAY, MUFFLER COVER	(1)	(1)	-	-	(1)	LXE4, LXQ4, LXQ4/A, QE, QE/A, QHB4, QHB4/A, QHQ4, QKA4, QKA4/A, QXB7, QXB7/A, QXB9, QXC4, QXE4, QXE4/A, QXQ4, QXQ4/A, QZX4, SE SE/A, SE1, SE2, SHQ4, SHQ4/A, SME0, SME0/A, SXE4, SXE4/A, SXQ4 SXQ4/A, VXB7, VXB9, VXE7, VXE9	
19	90006-Z5T-000	SCREW, TAPPING, 6X25	(1)	(1)	-	-	(1)	LXE4, LXQ4, LXQ4/A, QE, QE/A, QHB4, QHB4/A, QHQ4, QKA4, QKA4/A, QXB7, QXB7/A, QXB9, QXC4, QXE4, QXE4/A, QXQ4, QXQ4/A, QZX4, SE SE/A, SE1, SE2, SHQ4, SHQ4/A, SME0, SME0/A, SXE4, SXE4/A, SXQ4 SXQ4/A, VXB7, VXB9, VXE7, VXE9	



PART NO. INDEX

Part Number	Page	Ref.	Part Number	Page	Ref.	Part Number	Page	Ref.	Part Number	Page	Ref.	Part Number	Page	Ref.
06000			13000			14410-Z1C-000	50	4	16016-Z1E-V21	76	5	16166-ZE3-F10	76	12
06111-ZK3-U61	142	1	13010-Z5L-004	48	1	14410-ZK6-880	50	3	16016-ZH7-W01	67	5	16166-ZE3-F30	69	11
06111-ZK3-W01	142	1	13010-Z5R-004	48	1	14431-ZE2-010	50	5		76	5	16166-ZE3-W10	69	11
06160-Z1C-305	79	51	13010-Z5T-003	48	1	14441-ZE2-000	50	6		80	5	16166-ZE3-W20	69	11
			13011-Z5L-004	48	1	14451-Z4M-000	51	7	16024-124-760	76	6	16166-ZE3-W50	69	11
			13011-Z5R-004	48	1	14451-ZE1-013	51	7	16024-Z5T-901	67	6	16172-ZE3-W10	69	12
			13011-Z5T-003	48	1	14568-ZE1-000	51	8		80	6		77	13
			13012-Z5L-004	48	1	14711-Z5T-000	51	9	16024-ZE1-811	67	6	16173-001-004	69	13
11300-Z1C-000	38	1	13012-Z5R-004	48	1	14711-Z5T-900	51	9	16028-Z5T-901	67	7		80	22
11300-Z1C-010	38	1	13012-Z5T-003	48	1	14711-ZE3-000	51	9		80	7	139	1	16511-ZE8-000
11300-Z1C-600	38	1	13013-Z5L-004	48	1	14721-Z5T-000	51	10	16028-Z7E-E61	76	7		80	23
11300-Z1C-601	38	1	13013-Z5R-004	48	1		52	10	16028-ZA0-931	76	7	16178-ZJ0-911	80	23
11300-Z5T-W10	43	18	13013-Z5T-003	48	1	14721-Z5T-900	51	10	16028-ZE0-005	67	7	16211-Z8T-000	69	14
11300-Z8W-800	38	1	13101-Z1C-900	49	2		52	10	16044-Z8T-W01	80	8	16211-Z8T-W00	81	24
11300-ZE3-614	44	1	13101-ZE3-800	49	2	14721-ZE3-000	51	10	16044-ZE3-811	67	8	16211-Z9H-700	77	14
11300-ZE3-615	44	1	13101-ZE3-W01	48	2	14751-Z1C-000	52	11	16044-ZE3-W20	67	8	16211-ZE3-000	69	14
11381-Z5T-000	39	2	13102-Z5T-800	49	2	14771-Z8S-000	52	12	16045-Z5T-W01	80	9	16211-ZE3-W00	77	14
	44	2	13102-ZE3-W01	49	2		52	12	16100-Z5L-F12	76	8	16531-Z0A-000	41	10
11381-ZE3-801	38	2	13103-Z5T-800	49	2	14773-Z8S-000	52	13	16100-Z8T-801	68	9		44	10
	44	2	13103-ZE3-W01	49	2	14775-ZE2-010	52	14	16100-Z8T-811	67	9	16541-ZE3-010	35	3
11500-Z8T-612	130	1	13104-Z5T-800	49	2	14781-ZE2-000	52	15	16100-Z8T-821	67	9	16550-ZE3-700	114	1
11500-Z8T-640	131	1	13104-ZE3-W01	49	2	14791-Z1D-000	53	16	16100-Z8T-831	67	9	16551-ZE3-000	114	2
11521-ZE2-800	130	2	13111-Z5T-000	49	3	14791-ZE2-010	52	16	16100-Z8T-901	68	9	16555-ZE3-W00	114	3
	131	2	13111-ZF6-000	49	3		53	16	16100-Z8T-902	68	9	16561-ZE3-000	115	4
			13200-Z1C-000	49	4	15000	53	17	16100-Z8T-911	68	9	16561-ZE3-710	115	4
			13200-Z1C-305	49	4				16100-Z8T-922	68	9	16562-ZE3-000	115	5
12000-Z5T-405	33	1	13200-Z1C-900	49	4	15510-ZE2-053	34	2	16100-Z8T-931	68	9	16562-ZE3-700	115	5
	34	1	13200-ZE3-315	49	4	15600-Z0T-820	39	3	16100-Z8T-932	68	9	16570-ZE3-700	115	8
12000-Z5T-406	33	1	13310-ZE3-020	45	1		39	3	16100-Z8T-W01	80	10	16570-ZE3-721	116	9
12000-Z5T-407	33	1	13310-ZE3-602	45	2	15600-Z1C-000	39	4	16100-Z8T-W02	80	10	16570-ZE3-W00	115	6
12000-Z5T-415	33	1	13310-ZE3-612	45	3		44	3	16100-Z8T-W11	68	9	16570-ZE3-W10	115	7
	34	1	13310-ZE3-641	45	4	15600-Z1C-000	39	4	16100-Z9H-702	76	8	16570-ZE3-W20	115	6
12000-Z5T-416	33	1	13310-ZE3-652	45	5		43	19	16100-Z9H-802	68	9	16221-ZF6-800	70	16
	34	1	13310-ZE3-672	45	6	15625-Z0T-800	39	5	16100-Z9H-811	68	9	16221-ZE3-800	70	16
12000-Z5T-417	33	1	13310-ZF6-D42	47	12		44	4	16100-Z9H-822	76	8	16223-ZE3-800	71	17
	34	1	13310-ZF6-W12	45	2	15721-Z23-H60	32	17	16100-Z9H-861	76	9		77	16
12000-Z5T-Q20	33	1	13310-ZF6-W22	45	3		44	5	16100-Z9H-WA1	76	8	16223-ZE3-W00	71	17
12000-Z8T-405	33	1	13310-ZF6-W32	45	4	15721-ZB4-000	85	1	16100-ZE3-F31	68	9	16230-ZE3-702	77	17
12000-Z8T-406	33	1	13310-ZF6-W42	45	6		140	1	16110-Z8T-W01	80	11	16260-ZE2-723	77	18
12000-Z8T-407	33	1	13310-ZF6-W62	45	5				16110-Z8T-W02	80	11	16260-ZE3-D22	77	18
12200-Z1C-406	28	1	13310-ZF6-W72	45	1	16000			16111-Z5T-W01	80	12	16261-ZE2-702	77	19
12204-ZE2-306	28	2	13310-ZK3-601	45	2	16010-ZA0-921	76	1	16112-Z5T-W01	80	13	16262-ZE2-711	77	20
12205-ZE2-305	28	3	13310-ZK3-671	45	6	16010-ZE2-812	65	1	16112-Z5T-W01	80	13	16263-ZA0-000	77	21
12209-ZE8-003	50	1	13310-ZK6-602	45	2		80	1	16113-Z5T-W01	80	14	16264-ZE2-701	77	22
12210-Z5T-406	28	1	13310-ZK6-672	45	6	16010-ZE3-701	76	1	16115-Z5T-W01	80	15	16265-ZE2-721	77	23
12210-Z5T-416	28	1	13351-Z1C-900	46	7	16011-ZA0-931	65	2	16116-Z5T-W01	80	16	16268-893-000	120	1
12216-ZE2-300	29	4	13351-ZE3-010	45	7		80	1	16117-Z5T-W01	80	17	16268-ZE2-721	77	24
12251-Z5T-003	29	5		46	7		76	2	16118-Z5T-W01	80	18	16269-ZA0-800	77	25
12251-Z8T-801	29	5				16013-Z1C-003	65	3	16119-Z5T-W01	80	19	16271-ZE2-010	82	1
12310-Z5T-000	29	6	14000				80	2	16124-Z5T-W01	80	20		84	1
12310-Z5T-800	29	6					66	3	16124-ZE0-005	68	10	16400-ZE2-704	77	26
12310-ZE2-020	29	6	14100-Z5K-810	50	2		76	3		76	10	16500-Z5T-000	115	6
12310-ZE3-791	29	6	14100-Z5K-820	50	2		80	3	16141-Z0S-003	75	36	16500-Z5T-305	115	6
12315-ZE3-840	29	7	14100-Z5K-910	53	21	16013-ZA0-931	66	3		81	40	16500-Z5T-306	115	7
12357-Z5T-010	32	17	14100-Z5K-920	53	21		76	3	16148-141-881	76	11	16500-Z5T-307	115	6
12357-Z5T-020	32	17	14100-ZE3-020	50	2		66	3	16166-Z8T-911	69	11	16500-Z5T-309	115	6
12391-ZE2-020	29	8	14100-ZK3-870	50	2	16015-Z5T-901	66	4	16166-Z8T-921	69	11	16500-Z5T-405	115	6
			14100-ZK3-880	50	2		80	4	16166-Z8T-W01	80	21	16500-Z5T-407	115	6
							76	4	16166-Z8T-WB1	69	11	16500-Z5T-408	116	8
							66	4	16166-Z9H-WA1	77	12	16615-893-000	77	29
												16615-ZE2-810	71	22



PART NO. INDEX

Part Number	Page	Ref.	Part Number	Page	Ref.	Part Number	Page	Ref.	Part Number	Page	Ref.	Part Number	Page	Ref.	Part Number	Page	Ref.	
16646-Z5T-W01	81	29		140	8	17631-899-000	139	9		141	6	23411-Z1C-000	130	3	28463-Z5T-013	59	14	
16648-Z5T-W01	81	30	17231-ZE3-W01	82	4	17631-Z0T-801	101	8	18355-ZE2-W00	92	5	23710-ZE3-610	130	5			60	12
16731-ZE2-003	61	1	17232-891-000	82	5	17631-Z1T-800	101	8	18355-ZE3-010	97	8	23710-ZE3-640	131	5	28465-Z5T-W01	60	13	
16755-Z5T-W00	109	1		84	6	17670-899-000	139	10		98	7							
16854-ZH8-000	100	1		87	4	17672-Z4H-000	101	9	18381-Z1C-801	94	15	28000			30000			
16950-ZB4-015	139	2	17232-898-000	85	7	17850-ZD1-E30	120	2		97	10							
16952-ZB4-005	139	3	17233-896-701	143	1					98	9	28400-Z5T-003ZA	55	1	30201-PH9-004	113	1	
16953-ZE1-812	71	23	17233-Z23-H60	90	8	18000			18381-Z8S-801	92	6	28400-Z5T-003ZB	55	1	30202-PZ1-003	113	2	
	81	31		140	9					93	6	28400-Z5T-013ZA	54	1	30421-Z5T-W00	64	4	
16954-ZE1-812	71	24	17235-899-000	85	8	18310-Z1C-842	141	1		97	9				30500-Z1C-023	106	1	
	81	32	17235-Z5R-800	83	7	18310-Z5T-010	91	1	18381-ZE2-801	94	15	28400-Z5T-013ZB	54	1	30500-Z5T-003	106	1	
16955-ZE1-000	100	2	17235-Z5T-000	87	5	18310-Z8T-000	96	1	18381-ZE2-W10	92	6				30500-Z5T-004	106	1	
16955-ZE1-010	100	2	17235-Z5T-800	87	5					93	6	28400-Z5T-305ZA	54	1	30561-ZB4-000	137	1	
16956-ZE1-811	72	25	17235-ZH9-N01	83	6	18310-Z8T-010	98	1		97	9	28400-Z5T-305ZB	54	1	30595-Z5T-W01	107	6	
	81	33	17236-899-000	85	9	18310-Z8T-800	96	1		98	8	28400-Z5T-W02ZA	60	1	30596-Z5T-W00	107	16	
16957-ZE1-812	72	26	17238-ZE2-310	83	8				18381-ZE3-830	98	8	28400-Z5T-W02ZB	60	1	30700-Z1C-811	106	2	
	81	34		84	7	18310-Z8W-V62	141	12	18430-ZF6-W50	97	11	28400-Z5T-W03ZA	60	1	30700-Z1C-813	106	2	
16958-397-771	139	4		87	6	18310-ZE2-U91	141	1		144	15	28400-Z5T-W03ZB	60	1				
16959-471-831	139	5	17238-ZG9-M00	90	14	18310-ZE2-U92	141	1	18433-Z5T-000	143	2	28400-ZE3-W01ZB	54	1	31000			
16959-Z5T-901	75	35		140	15	18310-ZE2-W61	91	1	18434-Z5T-000	143	3	28400-ZE3-W01ZC	54	1				
	81	35	17239-ZE1-000	83	9	18310-ZE3-003	98	1	18436-ZH8-W41	143	4	28400-ZE3-W01ZE	54	1	31100-ZE3-701	105	6	
16967-GA6-671	139	6		87	7	18310-ZE3-W00	96	1	18437-Z5T-000	144	18	28400-ZE3-W01ZH	54	1	31100-ZE3-722	105	7	
16967-ZE0-811	72	27	17239-ZE3-840	84	8	18310-ZK6-880	91	1	18466-ZH8-W40	143	7	28400-ZE3-W01ZP	54	1	31100-ZE3-U10	104	4	
	81	36	17252-899-000	85	10	18320-Z5T-000	93	11				28400-ZE3-W02ZC	54	1	31100-ZE3-W01	104	5	
			17316-611-000	29	9	18320-Z5T-800	93	11	19000			28400-ZE3-W02ZE	54	1	31100-ZE3-W21	104	5	
			17367-413-690	85	11	18320-ZC2-000	141	2				28400-ZE3-W02ZH	54	1	31110-Z5T-000	105	6	
			17410-Z5T-020	87	8	18320-ZE3-G10	98	2	19511-ZE3-000	104	1	28410-Z5T-W02ZA	60	2	31110-Z5T-810	105	12	
17210-Z5T-W00	86	1	17410-Z5T-W00	87	8	18320-ZE3-G11	98	2	19511-ZK6-880	104	1	28410-Z5T-W02ZB	60	2	31110-Z5T-820	105	7	
17210-ZE3-010	82	2	17410-ZE3-840	84	9	18320-ZE3-W01	96	2	19610-Z5T-000ZA	61	2	28410-ZE3-W01ZB	55	2	31110-Z5T-830	104	4	
	84	2	17410-ZE3-841	84	9	18320-ZE3-W02	96	2	19610-Z5T-000ZB	62	2	28410-ZE3-W01ZD	55	2	31110-Z5T-840	105	5	
	86	1	17410-ZH9-N00	83	10	18320-ZF6-W01	91	2	19610-Z5T-800ZA	62	2	28410-ZE3-W01ZF	55	2	31110-Z5T-860	105	5	
17211-899-000	85	2	17417-Z5T-000	87	9	18320-ZF6-W02	91	2	19610-Z5T-800ZC	62	2	28410-ZE3-W01ZH	55	2	31110-Z5T-W00	105	11	
	90	1	17470-ZE3-842	84	10	18323-Z5T-W41	93	10	19610-Z5T-810ZA	62	2	28410-ZE3-W01ZP	55	2	31110-Z5T-W41	105	10	
	140	2	17475-ZE3-841	84	11	18323-Z5T-W40	96	3	19610-Z5T-810ZB	62	2	28411-Z5T-W01	60	3	31200-Z5T-W01	113	3	
17212-Z5R-000	85	3	17476-ZE3-841	84	12	18325-ZB4-000	141	3	19610-Z5T-W00ZA	64	1	28421-Z5T-W01	60	4	31203-PH9-004	113	4	
17218-ZE3-000	82	3	17510-Z5T-000ZA	103	16	18325-ZE3-G10	98	3	19610-Z5T-W00ZB	64	1	28421-ZE3-W01	55	3	31204-Z2E-003	113	5	
	84	3	17510-Z5T-000ZB	103	16	18329-ZB4-000	141	4	19610-ZE3-010ZB	61	2	28422-ZE2-W01	56	4	31204-ZA0-003	110	1	
	86	2	17510-Z5T-800ZA	103	16	18330-ZE2-000	98	4	19610-ZE3-010ZC	61	2		60	5	31206-ZE3-003	110	2	
17219-ZE3-840	84	4	17510-Z5T-800ZB	103	16	18330-ZE2-W00	91	3	19610-ZE3-010ZE	61	2	28441-ZE2-W01	56	5	31207-ZE3-003	110	3	
17220-Z23-S30	90	2	17510-Z5T-880ZC	100	3		96	4	19610-ZE3-010ZG	61	2		60	6	31207-ZE9-H01	113	6	
	140	3	17510-Z5T-880ZD	100	3	18330-ZE3-700	95	22	19610-ZE3-010ZL	61	2	28442-ZE2-W01	57	6	31208-Z5T-W00	113	7	
17220-Z5R-000	85	4	17510-ZE3-030ZA	100	3	18330-ZE3-710	141	13	19610-ZE3-W02ZE	61	2		60	7	31208-ZE3-003	110	3	
17222-Z23-H60	90	3	17510-ZE3-030ZB	100	3	18331-Z5T-000	91	3	19610-ZE3-W02ZF	61	2	28443-ZE2-W01	57	7	31209-PH9-004	113	8	
	140	4	17510-ZE3-030ZD	100	3	18331-ZE3-811	93	12	19619-ZL8-300Z	64	2		60	8	31210-PH9-004	113	9	
17222-ZC2-000	85	5	17510-ZE3-030ZE	101	3		96	5		144	16	28444-ZE2-W01	57	8	31210-ZE3-023	110	4	
17223-Z23-000	90	4	17510-ZE3-801ZA	100	3	18333-Z1C-801	98	5	19630-Z5T-W00	119	31		60	9	31210-ZE3-033	110	4	
	140	5	17510-ZE3-801ZB	100	3	18333-Z1C-901	91	4	19631-Z5T-000	62	3	28450-ZE3-W11	104	2	31211-PH9-004	113	10	
17223-Z23-S30	90	5	17510-ZE3-801ZC	100	3		92	4		64	3	28451-ZE3-W01	104	3	31211-ZE2-003	110	5	
	140	6	17510-ZE3-801ZE	100	3	18333-ZB4-801	141	5	19631-ZE3-W00	62	3	28461-Z5T-003	58	13	31212-PH9-004	113	11	
17223-ZBH-000	90	5	17532-ZK6-881	101	4	18333-ZF6-W01	91	4					59	13	31212-ZE3-003	111	6	
	140	6	17534-ZK6-881	101	5		92	4	22000				60	10	31213-P64-N01	113	12	
17228-Z5T-000	77	25	17536-ZK6-880	101	6		97	6				28461-Z5T-305	59	13	31213-ZE2-003	111	7	
17229-Z23-H60	90	6	17620-899-013	139	7		141	14	22103-ZE3-610	130	3		60	10	31214-PH9-004	113	13	
	140	7	17620-899-800	139	7	18333-ZK6-Y00	95	21	22103-ZE3-640	131	3	28461-ZE2-W02	57	9	31215-ZE2-003	111	8	
17230-ZE3-841	84	5	17620-Z4H-020	101	7	18336-ZE3-000	93	13				28461-ZE2-W03	57	9	31217-Z0A-003	113	14	
17231-899-000	85	6	17620-Z4H-900	101	7		97	7	23000			28462-ZE3-W01	57	10	31218-PH9-004	113	15	
17231-Z23-H60	90	7	17620-Z4H-910	101	7		98	6					60	11	31218-ZE3-003	111	9	
17231-Z5T-000	86	3	17620-Z4H-920	101	7	18350-Z5T-800	94	14	23220-ZE3-610	130	4	28463-Z5T-003	59	14	31219-Z5T-W00	113	16	
17231-ZBH-000	90	7	17630-Z8V-003	139	8	18355-ZB4-630	95	23	23220-ZE3-640	131	4		60	12	31219-ZE2-003	111	10	

PART NO. INDEX

Part Number	Page	Ref.	Part Number	Page	Ref.	Part Number	Page	Ref.	Part Number	Page	Ref.	Part Number	Page	Ref.	Part Number	Page	Ref.
31219-ZE3-003	112	21	31630-ZE2-861	107	8	35000			53000			87539-Z0J-810	135	23	90014-ZE2-000	29	10
31220-PH9-004	113	17	31630-ZE2-W01	107	7							87565-Z5T-W00	135	24	90014-ZE6-000	107	13
31222-ZE3-791	111	11	31700-124-008	122	5	35100-Z5T-811	122	10	53149-964-003	77	31	87594-Z5T-W00	126	21	90015-883-000	107	14
31223-PA0-006	113	18		137	2	35100-Z5T-821	122	10				87594-ZB4-A00	133	12	90015-Z5T-000	118	21
31231-PH9-004	113	19	31711-Z5T-W00	126	23	35100-Z5T-831	129	8	68000			87602-Z8T-W00	135	25	90015-ZE5-010	118	21
31231-ZE2-003	111	12	31712-Z5T-W00	127	24	35100-Z5T-841	129	8							90016-ZG9-N30	119	22
31232-ZE3-003	111	13	31713-Z5T-W01	127	25	35100-Z5T-W01	126	7	68325-899-000	137	16				90018-ZK6-P10	30	12
31233-PH9-004	113	20	31750-Z0A-811	126	2	35100-Z5T-W21	126	7	68325-ZC2-000	137	17	88000			90029-888-000	37	20
31233-ZE2-003	111	14				35100-ZB4-023	137	5				88911-MJ3-000	77	32	90042-ZE3-700	30	11
31510-ZE1-811	107	6	32000			35100-ZE2-033	122	10	76000						90042-ZE8-000	30	11
31510-ZE3-003	107	21				35100-ZE2-843	122	10	76122-952-000	139	12	89000			90042-ZK6-D70	30	11
31511-Z5T-W00	107	17	32105-ZJ1-800	126	3	35100-ZE2-862	124	12				89216-Z0T-800	133	13	90047-ZE3-791	30	12
31511-Z5T-W10	108	25	32110-Z5K-000	128	6	35100-ZE2-W01	125	12	81000			89216-ZB4-000	133	13	90050-ZE1-000	93	8
31511-ZE2-W00	106	3				35110-Z5T-W01	126	8									
31511-ZE3-000	106	4	32110-Z5K-800	123	26	35110-Z5T-W11	126	9	81329-567-020	63	6						
31512-Z5T-W00	107	18	32110-Z5K-810	123	26	35111-880-013	122	11				90000					
31512-ZE2-000	107	5															
31600-ZE2-861	124	1							87000								
	128	1	32110-Z5T-000	128	6							90001-ZE8-000	49	5			
	138	26										90002-Z0T-800	141	7			
31610-Z5R-821ZA	124	2	32110-Z5T-810	123	26	35120-Z0D-V81	62	4	87117-Z2E-800	126	12	90002-Z5T-W00	64	5			
31610-Z5R-821ZB	124	2				35120-Z5T-003	63	5	87501-Z5T-W00	126	13	90002-ZE2-U91	141	7	90050-ZH8-W40	143	9
31610-Z5S-802ZA	121	1				35480-Z5T-W01	37	18	87516-Z4H-000	132	1	90003-Z2E-000	64	6	90055-ZE1-000	95	20
31610-Z5S-802ZB	121	1	32110-Z5T-W00	109	2	35480-ZF6-003	34	2	87516-Z4H-010	132	1	90003-Z5T-W00	64	7			
31610-Z5S-821ZA	124	2	32110-Z5T-W10	109	2							90004-Z5T-000	63	8			
31610-Z5S-821ZB	124	2	32110-ZE2-860	124	8	36000						90004-ZE2-W01	57	11			
31610-Z5T-802ZA	121	1				36100-ZF6-P82	62	5	87516-Z4H-800	132	2						
31610-Z5T-802ZC	121	1				36101-ZE2-701	107	9	87516-Z4H-801	133	15	90005-ZM3-000	90	9	90101-692-000	144	17
31610-Z5T-811ZA	121	1	32110-ZE2-W00	124	7	36101-ZE3-800	107	9							90107-959-003	46	8
31610-Z5T-811ZB	121	1				36103-ZE1-000	107	10	87516-Z4H-810	133	14	90006-Z5T-000	144	19	90110-ZE2-003	111	16
31610-Z5T-821ZA	121	1	32115-Z5T-W00	37	17	36106-892-003	137	7	87516-ZK6-800	136	27	90006-ZE2-000	93	7	90114-SA0-000	119	23
31610-Z5T-821ZB	121	1	32127-738-700	122	6	36110-ZB4-702	137	8	87519-Z4H-000	132	1	90007-Z5T-W00	64	8	90121-952-000	64	10
31610-Z5T-831ZA	128	2	32130-ZE1-000	137	3	36135-ZF6-D41	77	30				90007-ZE2-003	111	15	90131-883-000	35	6
31610-Z5T-831ZB	128	2	32197-ZE1-003	122	7	36160-ZB4-013	120	3				90008-ZE2-003	58	12	90142-MB0-000	84	14
31610-Z5T-841ZA	128	2							87521-Z8T-000	132	3				90201-Z5T-W01	60	15
31610-Z5T-841ZB	128	2	32343-892-003	137	4	37000			87521-ZE3-W04	132	3	90009-Z1C-000	83	11	90201-ZE3-790	105	8
31610-Z5T-W00	126	22	32346-Z5T-W00	126	4				87522-883-660	132	4				90201-ZE3-V00	105	8
31612-ZE2-003	121	2	32612-Z5T-W00	126	5	37150-Z5T-W01	126	10	87528-898-620	133	6				90202-Z1T-000	119	23
	124	3	32823-ZV5-003	109	3				87528-Z2E-800	135	17	90009-Z5T-W00	88	10	90202-Z2E-000	88	11
	128	3	32824-ZV5-003	109	4	38000			87528-Z4M-000	133	5	90009-ZE2-003	83	11	90203-ZA0-800	83	12
31614-Z5T-W00	126	1													90206-ZE1-000	53	19
31614-ZE2-003	121	3	32902-892-003	122	8	38216-Z2E-003	126	11	87528-Z5T-000	133	5	90012-888-000	107	11	90302-KF9-900	144	10
	124	4				38220-ZE1-000	137	9							90325-044-000	83	13
	128	4				38240-VA3-900	122	12	87528-Z5T-W00	136	28						
31615-ZE3-003ZA	121	4							87528-ZH7-000	132	5	90012-ZE0-010	53	18			
	124	5	34000			38240-ZE2-840	123	12	87529-Z4S-820	125	14	90013-883-000	35	5	90380-MA6-010	123	16
	128	5				38250-898-000	137	11									
31615-ZE3-003ZD	121	4	34150-ZH7-013	35	4	38250-ZA8-701	123	13	87529-Z4T-840	123	14						
31615-ZE3-003ZE	121	4				38251-898-000	137	12	87531-Z5T-W00	135	19				90380-MB2-000	126	15
	124	5				38252-898-000	137	13	87532-ZH7-000	133	7				90413-ZK6-880	53	20
	128	5	34750-Z5T-W11	109	5	38253-898-000	137	14							90431-ZE2-700	77	33
31620-ZG5-033	124	6	34750-Z5T-W61	109	5	38254-898-000	137	15	87533-ZC0-630	133	8				90432-ZE2-700	78	34
	129	20	34750-Z5T-W62	109	5				87534-ZE1-841	133	9				90433-ZE2-700	78	35
31630-Z1C-003	107	7	34750-Z5T-W71	109	5	50000			87535-ZE1-841	133	10				90434-ZE2-700	78	36
31630-Z5T-W01	107	21	34750-Z5T-W72	109	5				87539-898-620	133	11				90441-ZE2-010	30	13
31630-Z5T-W11	107	21	34750-Z5T-W82	109	5	50319-ZB2-000	139	11	87539-Z0J-000	135	17				90446-KE1-000	35	7
31630-Z5T-W21	107	19													90473-842-000	46	9
31630-ZE1-013	107	6													90473-ZE3-010	46	9
31630-ZE2-842	107	6							87539-Z0J-800	135	19	90014-Z5T-000	29	10	90503-898-000	139	13



PART NO. INDEX

Part Number	Page	Ref.	Part Number	Page	Ref.	Part Number	Page	Ref.	Part Number	Page	Ref.	Part Number	Page	Ref.	Part Number	Page	Ref.
90534-706-010	46	9	91424-Z5L-802	101	12	94050-05000	85	13		44	15	99101-ZH8-1080	73	33			
90601-Z5T-W00	126	16		102	12	94050-06000	60	16		130	10	99204-ZA0-0400	74	34			
90601-ZE3-000	49	6	91424-Z5L-812	102	12		83	15		131	10	99204-ZE0-0350	74	34			
90602-ZE1-000	41	11		139	15		84	16	95701-10040-00	113	22		75	34			
	44	11	91424-Z5L-813	139	15		85	14	95701-10080-00	31	15		79	49			
90605-230-000	72	28	91424-Z5L-822	102	12		89	13				99204-ZE0-0380	74	34			
	119	24	91424-Z5M-812	139	15		90	12	96000				79	49			
90630-751-000	123	17	91424-Z5R-802	139	15		119	30				99204-ZE0-0450	74	34			
	125	17	91424-Z5T-003	101	12		140	13	96100-62020-00	37	15	99204-ZE2-0380	81	39			
	129	13		102	12	94050-08000	93	9		43	16	99204-ZE2-0400	74	34			
90634-ZL8-H00	83	14	91424-Z5T-013	102	12		97	17		44	16		75	34			
	85	12	91424-ZBH-811	102	12		99	12	96100-62040-00	44	17						
	89	14	91424-ZBH-812	102	12		102	13	96100-62060-00	130	11						
90650-SD9-003	78	37	91424-ZBH-831	139	15		141	8	96100-62070-00	43	17						
90654-SA4-003	63	9	91424-ZBH-832	139	15	94050-10000	36	11		44	18						
90672-SA0-003	123	18	91424-ZBH-851	102	12	94070-06080	111	19		47	11						
	125	18	91541-S0A-003	109	6	94070-08080	113	21	96100-63020-00	131	11						
	129	14	91551-898-000	139	16	94101-04800	123	23	96205-10010	37	16						
90684-ZA0-601	107	15	91565-SEL-003	126	17		125	22									
90701-HC4-000	41	12	91601-ZE2-003	111	17	94101-06800	42	14	98000								
	44	12					44	14									
90741-805-000	47	10	92000			94103-05000	78	41	98079-55846	31	16						
	130	6				94103-05700	144	13		32	16						
90741-889-810	47	10	92101-08025-0A	46	8	94109-12000	36	12	98079-55855	31	16						
	130	6	92900-08032-0E	30	12	94111-04800	123	24	98079-55876	31	16						
90741-ZE2-000	105	9					125	23		137	19						
90745-ZE2-600	46	10	93000				129	18	98079-56855	31	16						
	131	6				94251-10000	37	13		32	16						
90802-Z6L-000	90	10	93500-03006-1H	73	29	94301-08140	130	9	98079-56876	31	16						
	140	11		81	37		131	9	98200-30500	123	25						
90851-898-000	139	14	93500-03012-0H	123	20	94301-12200	31	14		137	20						
90854-ZB3-000	90	11	93500-04006-0H	73	30	94305-20122	73	32	98200-31500	123	25						
	103	17		119	25	94540-02010	78	42		125	24						
	137	21	93500-04012-0H	123	21	94540-04010	78	43		129	19						
	140	12		125	20	94540-07010	78	44	98200-32500	125	24						
				129	16					129	19						
91000			93500-05008-0A	120	5	95000			98200-43000	126	20						
			93500-05012-0A	78	38												
91001-ZF6-013	47	11	93500-05016-0A	119	26	95002-02070	78	45	99000								
91004-KZR-602	37	15	93500-05032-0A	119	27	95002-02080	137	22									
	43	16	93500-05035-0A	119	28	95002-02130	137	23	99101-ZH8-0880	73	33						
	44	16	93500-05045-0A	119	29	95002-40800-08	103	14		81	38						
91006-MT3-003	131	7	93500-06006-0B	97	16		138	24	99101-ZH8-0900	73	33						
91009-KJ1-003	44	13	93891-04008-08	127	26		139	17	99101-ZH8-0920	73	33						
	130	7	93891-04010-08	126	18	95002-50000	138	25		74	33						
91201-Z1C-003	35	8	93891-04020-07	109	7	95005-11105-30	29	7		81	38						
	41	13	93891-06020-07	144	12	95005-35075-10	78	46	99101-ZH8-0950	73	33						
91201-Z1D-003	130	8	93892-05012-18	78	39	95005-35130-10	78	47		79	48						
	131	8	93892-05032-18	111	18	95701-06010-00	58	12		81	38						
91201-Z7E-003	35	8	93893-04020-08	127	27		141	9	99101-ZH8-0980	73	33						
91203-952-771	35	9	93893-05016-00	73	31	95701-06012-00	37	14		79	48						
91203-Z7E-003	35	9	93913-24310	126	19		141	10		81	38						
91309-Z6L-000	37	21	93913-25580	64	11	95701-06032-08	90	13	99101-ZH8-1000	73	33						
91353-671-004	36	10					140	14		74	33						
	101	11	94000			95701-08020-00	141	11		79	48						
91406-ZE2-003	123	19				95701-08025-00	46	8	99101-ZH8-1020	73	33						
	125	19	94001-04390-0S	123	22		103	15		74	33						
	129	15		125	21	95701-08035-08	112	20		79	48						
91424-Z5K-003	139	15		129	17	95701-08040-00	42	15	99101-ZH8-1050	73	33						

PART NAME INDEX

Part name	Page	Ref.	Part name	Page	Ref.	Part name	Page	Ref.
[A]			BOLT, FLANGE, 6X10	58	12	BRACKET, CENTER	110	5
ALERT UNIT, OIL	35	4		101	10	BRACKET, FR.	111	6
	122	9	BOLT, FLANGE, 6X12	141	9	BRACKET, SWITCH BOX	126	1
	124	11		35	5	BRUSH	111	8
ARMATURE COMP.	110	2		37	14		113	10
	113	14			19	BUSH, ARM PIVOT	77	31
ARM COMP., GOVERNOR	114	1			7	BUSH, CONTROL KNOB	137	7
ARM, CHOKE	80	13			64			
ARM, GOVERNOR	114	2			94	[C]		
ARM, MANUAL START	80	9	BOLT, FLANGE, 6X16	37	20	CAMSHAFT ASSY.	50	2
ARM, VALVE ROCKER	50	5	BOLT, FLANGE, 6X25	64	10	CAMSHAFT COMP.	53	21
ARRESTER COMP., SPARK	94	14	BOLT, FLANGE, 6X28	107	14	CAP ASSY., NOISE SUPPRESSOR ...	106	2
ARRESTER, SPARK	92	5	BOLT, FLANGE, 6X32	90	13	CAP ASSY., OIL FILLER	39	3
	95	23		140	14			
	97	8	BOLT, FLANGE, 6X35	107	13			
	98	7		108	23	CAP, CHOKE DUST	76	11
	141	6	BOLT, FLANGE, 6X40	107	11	CAP, LENS	137	13
[B]				141	10	CAP, MUFFLER	93	12
BAND	122	8	BOLT, FLANGE, 8X20	108	23		96	5
	124	10	BOLT, FLANGE, 8X25	141	11	CAP, PRE AIR CLEANER	84	11
	129	7		46	8	CAP, SEALING	83	14
BARREL ASSY., CYLINDER	33	1	BOLT, FLANGE, 8X35	103	15		85	12
	34	1		103	15		89	14
BASE COMP., AIR CLEANER	90	5	BOLT, FLANGE, 8X35	112	20		90	10
	140	6	BOLT, FLANGE, 8X40	42	15	CARBURETOR ASSY.	67	9
BASE COMP., CONTROL	117	15		44	15		68	9
BASE COMP., MUFFLER COVER	143	4	BOLT, GOVERNOR ARM	130	10		76	8
BEARING A	113	8	BOLT, HEAD COVER	131	10		80	10
BEARING B	113	9	BOLT, HEX., 8X25	118	21	CARBURETOR SET	80	11
BEARING, RADIAL BALL, 6202	37	15	BOLT, PIVOT, 8MM	29	10	CASE COMP., AIR CLEANER	85	4
	43	16	BOLT, SPECIAL, 6MM	46	8		90	2
	44	13	BOLT, STUD	53	18		140	3
		16		64	6	CASE COMP., FUSE	137	9
		16	BOLT, STUD, 8X106	64	5	CASE COMP., MOTOR	81	29
BEARING, RADIAL BALL, 6204	130	7	BOLT, STUD, 8X115	64	5	CASE COMP., PRE AIR CLEANER ...	84	10
BEARING, RADIAL BALL, 6206	44	17	BOLT, STUD, 8X131.5	7	7	CASE COMP., RECOIL STARTER	55	2
	130	11	BOLT, STUD, 8X22	30	11		60	2
	131	7	BOLT, STUD, 8X25	30	11	CASE, CONTROL	121	2
BEARING, RADIAL BALL, 6207	43	17	BOLT, STUD, 8X25	30	12		124	3
	44	18	BOLT, STUD, 8X25	30	12		128	3
	47	11	BOLT, STUD, 8X32	30	12	CHAMBER SET, FLOAT	66	4
BEARING, RADIAL BALL, 6207SH ..	47	11	BOLT, THROUGH	30	12		76	4
BEARING, RADIAL BALL, 6302	131	11	BOX ASSY., CONTROL	113	13		80	4
BOLT-WASHER, 5X14	111	15		121	1	CHOKE SET	67	8
BOLT-WASHER, 6X18	88	10		124	2		80	8
BOLT-WASHER, 6X22	83	11	BRACKET A, HARNESS	126	22	CIRCLIP, 5MM	72	28
	84	13	BRACKET B, HARNESS	128	2		119	24
	88	10		37	17	CLAMPER, CORD	106	3
BOLT B, STUD	64	8	BRACKET, CASE MOUNTING	107	16			
BOLT KIT, FUEL CHAMBER	79	51		121	3		107	17
BOLT, CONNECTING ROD	49	5		124	4		108	25
BOLT, DRAIN PLUG, 12X15	35	6		128	4			
BOLT, FLANGE, 10X40	113	22		128	4			
BOLT, FLANGE, 10X80	31	15			4			
BOLT, FLANGE, 5X18	90	9			4			
	140	10			4			



PART NAME INDEX

Part name	Page	Ref.	Part name	Page	Ref.	Part name	Page	Ref.
CLAMP, TUBE	103	14	CONTROL ASSY.	116	8	[E]		
	138	24			9			
	139	17	CONTROL UNIT, ELECTRONIC	109	5	ELBOW COMP., AIR CLEANER	83	10
CLIP A, AIR CLEANER WIRE	85	8	CORD, CHARGE COIL	126	23		84	9
CLIP B, AIR CLEANER WIRE	85	9	CORD, EARTH	127	24		87	8
CLIP, BREATHER TUBE	29	9	CORD, STOP SWITCH	107	9	ELEMENT COMP., AIR CLEANER	86	1
CLIP, COUPLER	126	17	COUNTERSHAFT COMP.	130	4	ELEMENT, AIR CLEANER	82	2
CLIP, GOVERNOR HOLDER	41	11		131	4		84	2
	44	11	COUPLER COMP.	137	3		85	2
CLIP, HARNESS	107	15	COVER	113	12		86	1
CLIP, HARNESS BAND	109	6	COVER ASSY., CRANKCASE	38	1		90	1
CLIP, PISTON PIN, 20MM	49	6		43	18		140	2
CLIP, PURSE LOCK	123	17		44	1	EMBLEM	132	3
	125	17	COVER ASSY., FUSE	126	11	E-RING, 2MM	78	42
	129	13	COVER ASSY., GEAR CASE	130	1	E-RING, 4MM	78	43
CLIP, SPECIAL	80	17		131	1	E-RING, 7MM	78	44
		18	COVER COMP., AIR CLEANER	84	5			
CLIP, TUBE	61	1		85	6	[F]		
	78	45	COVER COMP., CYLINDER HEAD ...	29	6			
	137	22	COVER COMP., FAN	61	2	FAN, COOLING	104	1
		23		62	2	FILTER COMP., FUEL	139	10
	138	25		64	1	FILTER, CUP	75	35
CLIP, VALVE GUIDE	29	4	COVER COMP., HEAD	29	6		81	35
CLIP, WIRE	137	1	COVER COMP., MUFFLER	143	2		139	5
CLIP, WIRE HARNESS	78	37	COVER COMP., RR. MUFFLER	143	3	FILTER, DRAIN TUBE	85	11
CLIP, WIRE HARNESS, 6MM	63	9	COVER, AIR CLEANER	82	4	FILTER, FUEL	101	9
CLUTCH COMP., OVERRUNNING	110	3		90	7	FILTER, OUTER	82	3
	113	6		140	8		84	3
COCK ASSY., FUEL	139	2	COVER, AIR CLEANER CASE	86	3		86	2
COIL ASSY., CHARGE	107	6	COVER, CONTROL	126	5	FLANGE COMP., BAFFLE	93	13
		7	COVER, CYLINDER HEAD	29	6		97	7
		8	COVER, ELECTRONIC PARTS	64	4		98	6
		19	COVER, RECOIL STARTER	60	3	FLOAT SET	65	3
COIL ASSY., IGNITION	106	1	COVER, ROPE	60	13		66	3
COIL ASSY., LAMP	107	6	CRANKSHAFT COMP.	45	1		76	3
		21			2		80	3
		21			3	FLYWHEEL COMP.	104	4
COIL ASSY., POWER	107	6			4		5	5
COLLAR B, AIR CLEANER	83	9			5		105	5
	84	8			6			6
	87	7		47	12			7
COLLAR SET, CLUTCH STOP	113	2	CUP, FUEL STRAINER	72	27			10
COLLAR, AIR CLEANER	83	8		81	36			11
	84	7		139	6			12
	87	6				FRAME COMP., COMMUTATOR END ...	113	16
	90	14	[D]			FUSE, BLADE	123	25
	140	15					125	24
COLLAR, AIR CLEANER CASE	143	1	DEFLECTOR COMP., MUFFLER	97	11		129	19
COLLAR, FAN COVER	64	2		144	15		137	20
	144	16	DIAPHRAGM ASSY.	77	26	FUSE, MINI	126	20
COLLAR, LEVER	78	36	DOWEL PIN, 12X20	31	14			
COLLAR, SETTING	69	12	DOWEL PIN, 8X12	41	12	[G]		
	77	13		44	12			
COLLAR, STOPPER	118	19	DOWEL PIN, 8X14	130	9	GASKET KIT	142	1
COLLAR, TANK CUSHION	139	16		131	9	GASKET SET	65	1
CONTACTOR ASSY.	110	1					76	1
CONTROL ASSY.	115	6					80	1
		7				GASKET, CYLINDER HEAD	29	5
		8						

PART NAME INDEX

Part name	Page	Ref.	Part name	Page	Ref.	Part name	Page	Ref.
GASKET, EX. PIPE	91	4	HEAD COMP., CYLINDER	28	1	KEY COMP.	122	11
	92	4	HOLDER, BRUSH	111	12		125	13
	95	21		113	19		126	8
	97	6	HOLDER, CABLE	71	18		129	9
	98	5		117	13		137	6
	141	5	HOLDER, GOVERNOR WEIGHT	40	8	KEY, 6.3X6.3X43	46	10
		14		44	8		131	6
GASKET, MUFFLER	92	6	HOLDER, LENS	137	15	KEY, 7X7X33	47	10
	93	6	HOLDER, STOP SWITCH CORD	107	10		130	6
	94	15	HOLDER, WIRE	71	20	KEY, SPECIAL WOODRUFF, 25X18 ..	105	9
	97	9		117	18	KNOB, COCK LEVER	137	4
		10	HOUSING COMP., DRIVE SIDE	113	7			
	98	8				[L]		
		9	[I]			LABEL, AIR CLEANER CAUTION	133	9
GEAR, DRIVE PINION	111	7	INDICATOR ASSY.	126	10	LABEL, FUSE	126	12
GEAR, MIDDLE	80	12	INSULATOR	111	14	LENS	137	12
GEAR, PRIMARY DRIVE	130	3	INSULATOR, BRUSH HOLDER	113	20	LENS ASSY., PROTECTOR	123	13
	131	3	INSULATOR, CARBURETOR	69	14		137	11
GEAR, REDUCTION	111	11		77	14	LEVER COMP., CHOKE	71	21
GOVERNOR ASSY.	39	6		81	24	LEVER COMP., THROTTLE	120	2
	44	6				LEVER, CHOKE	77	20
GRIP, REINFORCEMENT	59	14	[J]			LEVER, CHOKE CONTROL	80	14
	60	12	JET SET, PILOT, #35	74	34	LEVER, COCK	71	23
GRIP, STARTER	57	9		75	34		81	31
	58	13	JET SET, PILOT, #38	79	49	LEVER, CONTROL	116	10
	59	13		74	34	LEVER, MANUAL START	81	28
	60	10	JET SET, PILOT, #40	79	49	LEVER, PINION DRIVE	113	4
GROMMET, AIR CLEANER	82	5		81	39	LIFTER, VALVE	50	6
	84	6	JET SET, PILOT, #45	74	34			
	85	7	JET, MAIN, #100	73	33	[M]		
	87	4		74	33	MARK	135	19
GROMMET, CHOKE ROD	77	28	JET, MAIN, #102	79	48	MARK, AIR CLEANER	133	8
GROMMET, CONTROL BOX	126	16		74	33	MARK, AIR CLEANER SALES POINT ..	133	10
GROMMET, CORD	107	5	JET, MAIN, #105	73	33	MARK, CAUTION	132	4
		18	JET, MAIN, #108	73	33	MARK, CHOKE	132	5
GROMMET, DRAIN HOLE	63	6	JET, MAIN, #88	73	33		133	5
GROMMET, FENDER	77	32		81	38		135	6
GUIDE, CHOKE ROD	77	29	JET, MAIN, #90	73	33	MARK, CONTROL BOX	123	14
GUIDE, EX. VALVE	28	3	JET, MAIN, #92	73	33		125	14
GUIDE, IN. VALVE	28	2		74	33		129	10
GUIDE, PRE AIR CLEANER	84	12	JET, MAIN, #95	73	33	MARK, ENGINE SWITCH	126	13
GUIDE, PUSH ROD	52	16		81	38	MARK, EX. CAUTION	133	11
	53	16	JET, MAIN, #98	73	33		135	17
		17		79	48			
[H]			JOINT, FUEL TANK	100	2	MARK, FUEL	135	24
HARNESS ASSY., ENGINE WIRE	109	2	JOINT, ROD	77	21	MARK, OIL CAUTION	126	21
	123	26					133	12
	128	6	[K]			MARK, OPERATOR CAUTION	132	1
	129	6	KEY ASSY., COMBINATION SWITCH	126	9		133	14
HARNESS ASSY., SUB WIRE	124	7						
		8						
	126	3						
	129	21						
		22						
	138	27						
HARNESS, SUB WIRE	122	7						
	124	9						



PART NAME INDEX

Part name	Page	Ref.	Part name	Page	Ref.	Part name	Page	Ref.
MARK, OPERATOR CAUTION	133	15	[O]			PIPE, EX.	98	4
	134	15					141	13
	135	16	OIL SEAL, 30X46X8	130	8	PISTON	48	2
	136	26		131	8		49	2
		27	OIL SEAL, 35X52X8	35	8	PIVOT, ROCKER ARM	51	7
MARK, SALES POINT	135	25		41	13	PLATE	80	15
MARK, THROTTLE INDICATION	133	7	OIL SEAL, 8X14X5	35	9	PLATE, LEVER SETTING	71	24
	135	20	O-RING	69	13		81	32
METER ASSY., FUEL	139	8		80	22	PLUG, CONE TYPE, 10X10	37	16
MOTOR ASSY., STARTER	113	3	O-RING, 14MM	139	1	PLUG, INNER CONNECTOR	109	3
MOTOR UNIT, STARTER	110	4		36	10	PLUG, OUTER CONNECTOR	109	4
MUFFLER COMP.	91	1		101	11		126	6
	96	1	O-RING, 37.9X2.4	37	21	PLUG, SPARK	31	16
	98	1	O-RING, 4.8X1.9	80	23		32	16
	141	1	O-RING, 9.0X1.3	139	4		137	19
		12				PROTECTOR COMP., MUFFLER	91	2
			[P]				93	11
[N]			PACKING	111	17	PROTECTOR, CIRCUIT	96	2
NOSE, SILENCER	83	6	PACKING, AIR CLEANER	77	25		122	12
		7	PACKING, AIR CLEANER CASE	87	9		123	12
	87	5	PACKING, AIR CLEANER COVER	84	4	PROTECTOR, EX. PIPE	137	10
NOZZLE, MAIN	69	11	PACKING, CARBURETOR	70	16		93	10
	76	12		71	16	PROTECTOR, L. MUFFLER	96	3
	77	12		77	15	PROTECTOR, MUFFLER INNER	98	3
	80	21		81	27	PROTECTOR, MUFFLER OUTER	141	3
NUT-WASHER, 6MM	111	19	PACKING, CARBURETOR INSULATOR	71	17	PROTECTOR, R. MUFFLER	141	2
NUT-WASHER, 8MM	113	21		77	16	PROTECTOR, STARTER	98	2
NUT, AIR CLEANER COVER	88	11		81	25	PULLEY COMP., STARTER	104	2
NUT, FLANGE, 10MM	36	11	PACKING, CASE COVER	38	2	PULLEY, RECOIL STARTER	55	3
NUT, FLANGE, 5MM	85	13		44	2		60	4
NUT, FLANGE, 6MM	60	16	PACKING, CHAIN CASE COVER	130	2	PULLEY, STARTER	104	3
	83	15		131	2			
	84	16	PACKING, CRANKCASE COVER	39	2	[R]		
	85	14		44	2	RATCHET, STARTER	56	4
	89	13	PACKING, ELBOW	82	1		60	5
	90	12		84	1	RECTIFIER ASSY., REGULATOR	124	1
	119	30	PACKING, FUEL COCK	72	26		126	6
	140	13		81	34		128	2
NUT, FLANGE, 8MM	93	9	PACKING, FUEL FILLER CAP	101	8		128	1
	97	17		139	9		129	20
	99	12	PACKING, HEAD COVER	29	8		138	26
	102	13	PACKING, INSULATOR	71	17	RECTIFIER ASSY., SILICON	122	5
	141	8		77	16		137	2
NUT, HEX.	113	18	PACKING, OIL FILLER CAP	39	5	RECTIFIER COMP.	127	25
NUT, HEX., 4MM	123	22		44	5	RETAINER, EX. VALVE SPRING	52	13
	125	21	PANEL COMP., CONTROL	121	4	RETAINER, IN. VALVE SPRING	52	12
	129	17		124	5		52	13
	144	10		128	5	RETAINER, SPRING	57	8
NUT, HEX., 5MM	113	17	PANEL, CONTROL	126	4		60	9
NUT, HEX., 8MM	53	19	PIN, GOVERNOR WEIGHT	41	9	RING SET, PISTON	48	1
NUT, PIVOT ADJUSTING	60	15		44	9	RING, SNAP	113	1
NUT, PUSH	60	15	PIN, LOCK, 10MM	37	13	ROD ASSY., CONNECTING	49	4
NUT, SELF-LOCK, 6MM	119	23	PIN, PISTON	49	3	ROD COMP., PUSH	50	3
NUT, SPECIAL, 16MM	105	8	PIN, SPRING, 2X12	73	32	ROD, CHOKE	77	22
NUT, TANK MOUNTING	101	5	PIPE, EX.	91	3	ROD, CHOKE CONTROL	77	27
NUT, TOOL BOX SETTING	83	13		95	22	ROD, GOVERNOR	114	3
	84	15		96	4	ROD, PUSH	50	4
	88	12						
NUT, WING, 6MM	83	12						

PART NAME INDEX

Part name	Page	Ref.	Part name	Page	Ref.	Part name	Page	Ref.
ROPE, RECOIL STARTER	57	10	SCREW, SPECIAL, 6X12	123	16	SPRING, COCK LEVER	72	25
	60	11		125	16		81	33
ROTATOR, VALVE	52	15		129	12	SPRING, COIL	137	14
RUBBER A, TANK MOUNTING	101	4	SCREW, SPECIAL, 6X8	126	15	SPRING, CONTROL ADJUSTING	117	16
RUBBER COMP., TANK MOUNTING	101	6	SCREW, STOP	80	20	SPRING, FRICTION	56	5
RUBBER, BOTTOM	137	16	SCREW, TAPPING, 3X6	63	8		60	6
		17	SCREW, TAPPING, 4X14	126	19	SPRING, GOVERNOR	115	4
RUBBER, FUEL	90	11	SCREW, TAPPING, 4X6	95	20	SPRING, LEVER	116	11
	103	17			24	SPRING, MANUAL CHOKE	77	24
	137	21		97	14	SPRING, RATCHET	57	7
	140	12			15		60	8
RUBBER, SUPPORTER	100	1		144	17	SPRING, RETURN	71	22
RUBBER, TANK CUSHION	139	14	SCREW, TAPPING, 4X8	141	7	SPRING, STARTER RETURN	57	6
RUBBER, TANK MOUNTING	139	11	SCREW, TAPPING, 5X20	64	11		60	7
			SCREW, TAPPING, 5X25	143	9	SPRING, THROTTLE RETURN	115	5
[S]			SCREW, TAPPING, 5X8	93	8	SPRING, TORSION COIL	80	16
				95	17	SPRING, VALVE	52	11
SCREEN SET, FUEL STRAINER	139	3			18	SPRING, WEIGHT RETURN	51	8
SCREW-WASHER, 4X10	126	18			19	STARTER ASSY., RECOIL	54	1
SCREW-WASHER, 4X14	112	21		97	13		55	1
SCREW-WASHER, 4X20	109	7		98	10		60	1
	127	27			11	STAY ASSY., CHOKE CONTROL	71	19
SCREW-WASHER, 4X6	111	16		143	8	STAY ASSY., MANUAL CHOKE	77	18
SCREW-WASHER, 4X8	127	26	SCREW, TAPPING, 6X10	93	7	STAY COMP., SOLENOID	77	19
SCREW-WASHER, 5X12	78	39	SCREW, TAPPING, 6X25	144	19	STAY, AIR CLEANER	85	5
SCREW-WASHER, 5X16	73	31	SCREW, THROTTLE STOP	68	10		90	3
SCREW-WASHER, 5X32	111	18		76	10		140	4
SCREW-WASHER, 6X20	144	12	SEAL, AIR CLEANER	85	10	STAY, MUFFLER COVER	144	18
SCREW SET	67	7	SEAL, AIR CLEANER CASE	90	6	STOPPER, CHOKE ROD	77	23
	76	5		140	7	STOPPER, DISCHARGE GUARD	139	12
		7	SEAL, AIR CLEANER COVER	90	8	STRAP, CABLE, 118MM	123	18
	80	7		140	9		125	18
		19	SEAL, CHOKE LEVER	78	34		129	14
SCREW SET, DRAIN	67	6	SEAL, ELECTRONIC CONTROL UNIT COVER	109	1	SUSPENSION, COUPLER	122	6
	76	6		141	4	SWITCH ASSY., COMBINATION	122	10
	80	6	SEAL, MUFFLER PROTECTOR	50	1		124	12
SCREW SET, PILOT	67	5	SEAL, VALVE STEM	52	14		125	12
	76	5	SEAT, VALVE SPRING	85	3		126	7
	80	5	SEPARATOR, AIR CLEANER	35	3		129	8
SCREW, CENTER	57	11	SHAFT, GOVERNOR ARM	130	5		137	5
	60	14	SHAFT, P.T.O.	131	5	SWITCH ASSY., ENGINE KILL	137	8
SCREW, GLOVE BOX	137	18		62	3	SWITCH ASSY., ENGINE STOP	62	4
SCREW, PAN, 3X12	123	20	SHROUD	64	3		63	5
SCREW, PAN, 3X6	73	29		119	31	SWITCH ASSY., MAGNET	113	5
	81	37	SHROUD COMP., UPPER	41	10	SWITCH ASSY., OIL LEVEL	34	2
SCREW, PAN, 4X12	123	21	SLIDER, GOVERNOR	44	10		37	18
	125	20		120	3			
	129	16	SOLENOID ASSY.	70	15	[T]		
SCREW, PAN, 4X6	73	30	SPACER COMP., CARBURETOR	79	50	TANK COMP., FUEL	100	3
	119	25		81	26		101	3
SCREW, PAN, 5X12	78	38	SPACER, CONTROL LEVER	117	14		103	16
SCREW, PAN, 5X16	119	26	SPACER, MUFFLER COVER	143	7		29	7
SCREW, PAN, 5X16.5	84	14	SPRING, AIR CLEANER CASE LID	90	4	TUBE, 11X105	29	7
SCREW, PAN, 5X32	119	27		140	5	TUBE, 3.5X130	78	47
SCREW, PAN, 5X35	119	28	SPRING, BRUSH	113	11	TUBE, 3.5X75	78	46
SCREW, PAN, 5X45	119	29	SPRING, BRUSH RETURN	111	10	TUBE, BREATHER	29	7
SCREW, PAN, 5X8	120	5	SPRING, CABLE RETURN	117	17		32	17
SCREW, PAN, 6X6	97	16	SPRING, CHOKE RETURN	120	1			
SCREW, RECESSED, 5X25	119	22						



PART NAME INDEX

Part name	Page	Ref.	Part name	Page	Ref.	Part name	Page	Ref.
TUBE, BREATHER	85	1	WIRE, WATER COVER	111	13			
	140	1	WRENCH, PLUG	133	13			
TUBE, FASTENER, 30MM	123	19	WRENCH, SPARK PLUG	133	13			
	125	19						
	129	15	[Y]					
TUBE, FUEL, 4.2X165	102	12	YOKE COMP.	111	9			
TUBE, FUEL, 4.2X235	102	12		113	15			
TUBE, FUEL, 4.2X260	139	15						
TUBE, FUEL, 4.5X165	102	12						
	139	15						
TUBE, FUEL, 4.5X210	139	15						
TUBE, FUEL, 4.5X235	101	12						
	102	12						
TUBE, FUEL, 4.5X260	139	15						
TUBE, FUEL, 4.5X580	102	12						
[U]								
U-RING	81	30						
[V]								
VALVE ASSY., SOLENOID	77	17						
VALVE SET, FLOAT	65	2						
	76	2						
	80	2						
VALVE, DASHPOT CHECK	77	30						
VALVE, EX.	51	10						
	52	10						
VALVE, IN.	51	9						
[W]								
WASHER COMP., HEAD COVER	30	13						
WASHER, 8MM	46	9						
WASHER, 8.2X17X0.8	35	7						
WASHER, 8.5X42X4.5	46	9						
WASHER, CHOKE LEVER	77	33						
WASHER, CONTROL LEVER	117	12						
WASHER, DRAIN PLUG, 12MM	36	12						
WASHER, LOCK, 8.5X35X4.5	46	9						
WASHER, PLAIN	75	36						
	81	40						
WASHER, PLAIN, 4MM	123	23						
	125	22						
WASHER, PLAIN, 5MM	78	41						
	144	13						
WASHER, PLAIN, 6MM	42	14						
	44	14						
WASHER, SPRING, 4MM	123	24						
	125	23						
	129	18						
WASHER, TANK CUSHION	139	13						
WASHER, THRUST, 16.1MM	53	20						
WASHER, THRUST, 2.7X8	78	35						
WEIGHT, BALANCER	45	7						
	46	7						
WEIGHT, GOVERNOR	40	7						
	44	7						

1

FOREWORD INDEX

2

ENGINE GROUP

3

PART NUMBER INDEX

4

PART NAME INDEX

HONDA