

PARTS LIST

TAMPING RAMMER

***MT-76D***

305-02702

MIKASA SANGYO CO.,LTD.



# PARTS REMARK INDEX

## How to read the marks and remarks used in this parts book.

### Section 1 : Explanation of Code Use In “MRK” Column

OO : Interchangeable between the new part and the old one.

XX : Not Interchangeable between new and old.

OX : New part is usable for the old machine but the old part is not usable for the new machine.

XO : The old part is usable for the new machine but the new part is not usable for the old machine.

Note : In case of the lack of interchangeability between the new part and old part, a new part may be used by replacing all other parts found in the assembly. In this case, refer to section 2 for instruction on identifying other parts involved in a new assembly.

AD : Newly established(added)

DC : Suspended(discontinued)

NC : Part number changed

QC : Quantity used has been changed

NS : Not supplied individually but supplied in an assembly or a group.

AS : Special part designed to allow interchangeability between new and old part.

CR : Correction

### Section 2 : Items Found In “Remark” Column

Serial Numbers - Where indicated, this indicates a serial number range (inclusive) where a particular part is used.

Model Number - Where indicated, this shows that the corresponding part is utilized only with this specific model number or model number variant.

# or \* : All parts with the same number following # or \* belong to the same assembly. this part cannot be interchanged individually with any other assemblies to replace an old part (indicated by #), with a new part(indicated by \*), then all other parts of that assembly must be replaced with new ones.

Note : If more than one of the same reference number is listed, the last one listed indicates newest(or latest)part available.

### Section 3: Example

REF NO.	PART NO.	PART NAME	QTY	MRK	REMARKS
457(1)	5122-09230	Hinge Metal, Upper/24g	1		-1070 #3 (5)
457(2)	5072-09420	Hinge Metal, Upper M16	1	OX(3)	U1071-(6) * 3(7)

(1) Old part

(2) New part

(3) New part usable with old machine, but old part not usable with new machine (reference section 1).

(4) Old part number is used through this machine serial number.

(5) Old part, used in an assembly with other parts marked with #3. To use this part on a new machine, all other parts in this assembly must be replaced with old ones.

(6) New part put into use starting with this serial number and is still current.

(7) New part used in an assembly with other parts marked \* 3, to use this part as a replacement for an old part, all other \* 3 marked parts must be changed at the same time.

### Section 4: Items Found In “MK2” Column

(only for suspended products)

! OO (“OO” is shown in figure) : The part shown in lower line is supplied.

! SD : Not available due to termination of production.

! NS : Not supplied individually, but supplied in an assembly or a group.

! PD : Supplied as unit product.

SS : Not available after stock run out.

(The contents of this parts catalog are subject to change without notice.)

MT-76D

3HD0

CRANK CASE & ENGINE / クランクケース & エンジン関係

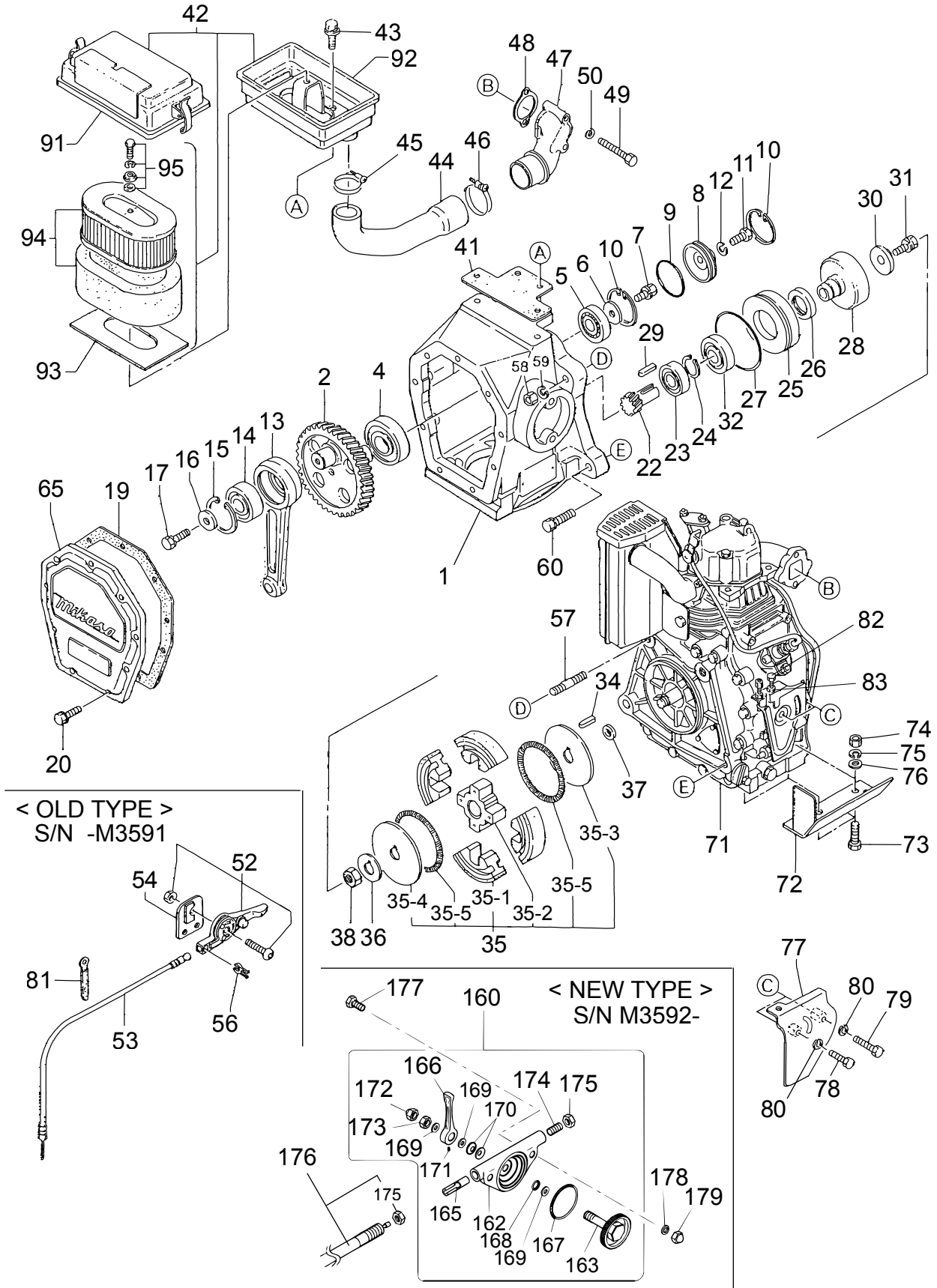

CRANK CASE & ENGINE

\*\* 3HD

\*\*

REF NO.	PART NO.	PART NAME	Q' TY	MRK	MK2	REMARKS
1	3711-13330	CRANK CASE /MT-76D	1	DC	!3711-13331	
1	3711-13331	CRANK CASE /MT-72, 76D	1			
2	3713-34400	CRANK GEAR /MT-76D	1			
4	0400-06207	BEARING 6207	1			
5	0400-06204	BEARING 6204	1			
6	9524-00130	WASHER 9304	1			
7	0022-10825	BOLT 8X25 H, SW	1			
8	3714-47650	BEARING COVER /MT-76D	1			
9	0503-00480	O-RING S-48	1			
10	0801-00480	STOP RING R-48	2			
11	0022-10610	BOLT 6X10 H, SW	1	DC		
11	0012-20610	BOLT 6X10 T	1	00		
12	0311-06100	PW M6	1			
13	3713-34730	CONNECTING ROD /MT-76D	1			
14	0400-06304	BEARING 6304	1			
15	0801-00520	STOP RING R-52	1			
16	9524-00130	WASHER 9304	1			
17	0022-10825	BOLT 8X25 H, SW	1			
19	3524-44450	PACKING, FRONT COVER/MT68	1			
20	0022-00620	BOLT 6X20 SW	9			
22	3714-47620	PINION /MT-76D	1			
23	0400-06204	BEARING 6204	1			
24	0802-00350	STOP RING S-35	1			
25	3714-49600	SPACER /MT-76D, 86D	1			
26	0604-04010	OIL SEAL TC-40528	1			
27	0501-01000	O-RING G-100	1			
28	3714-47640	CLUTCH DRUM /MT-76, 86D	1			
29	9524-05610	KEY 5X5X19R	1			
30	9524-05490	LOCK WASHER /MTR, MT	1			
31	0022-10820	BOLT 8X20 H, SW	1		!!R000160	
32	0410-06007	BEARING 6007Z	1			
34	22512-040120	KEY 4X 12	1			
35	3714-47633	CLUTCH AY/MT-D-3	1		SS!3714-63850	
35 -1	9430-20060	CLUTCH SHOE CP	4			
35 -2	9430-50050	CLUTCH BOSS C812	1			
35 -3	9430-60100	CLUTCH GAIDE/(A) 1. 6T, 1C	1			
35 -4	9430-60020	CLUTCH GUIDE/B	1			
35 -5	9430-30021	CLUTCH SPRING	1			
36	3010-10210	LOCK WASHER, CLUTCH	1			
37	3714-48260	SPACER 15X24X4 /MT76D, 86D	1			
38	0229-10170	NUT M12 (P1. 25-B17)	1			
41	3714-48220	PACKING, AIR CLEANER/MT-D	1			
42	3712-13392	AIR CLEANER AY /MT-D	1			
43	0022-00820	BOLT 8X20 SW	4			
44	3713-35110	INTAKE PIPE /MT-76D, 86D	1			
45	3710-00010	HOSE BAND (B) AH-1038	1			
46	3710-00020	HOSE BAND (B) AH-1050	1			
47	3713-35270	INTAKE FLANGE /MT-76D, 86D	1			
48	114284-12200	GASKET, AIR INTAKE	1			
49	0012-20652	BOLT 6X60 T	2			
50	0302-06150	SW M6	2			
52	9562-00040	THROTTLE LEVER ASSY S31	1	DC		-M3591
53	9561-08040	THROTTLE WIRE V490-640	1	DC		-M3591
54	3714-48000	LEVER STAY /MT-76D, 86D	1	DC		-M3591
56	3714-48300	CLIP (M)	1	DC		-M3591
57	26226-100402	STUD M10X20 PLATED	2			
57	26226-100452	STUD BOLT	2	00		
58	0203-10080	NUT M10	2			
59	0302-10250	SW M10	2			
59	0302-10250	SW M10	4	QC		
60	0022-11050	BOLT 10X50 H, SW	2			
60	0012-21050	BOLT 10X50 T	2	00		
65	3710-10010	FRONT COVER (STD) /MT-76D	1			STD.
65	3710-10020	FRONT COVER (MQ) /MT-76D	1			FOR MQ
71	9144-10003	ENGINE AY L40ADRM	1		SS!SD	#2 -2144/JP

MT-76D

3HD0

CRANK CASE & ENGINE / クランクケース & エンジン関係

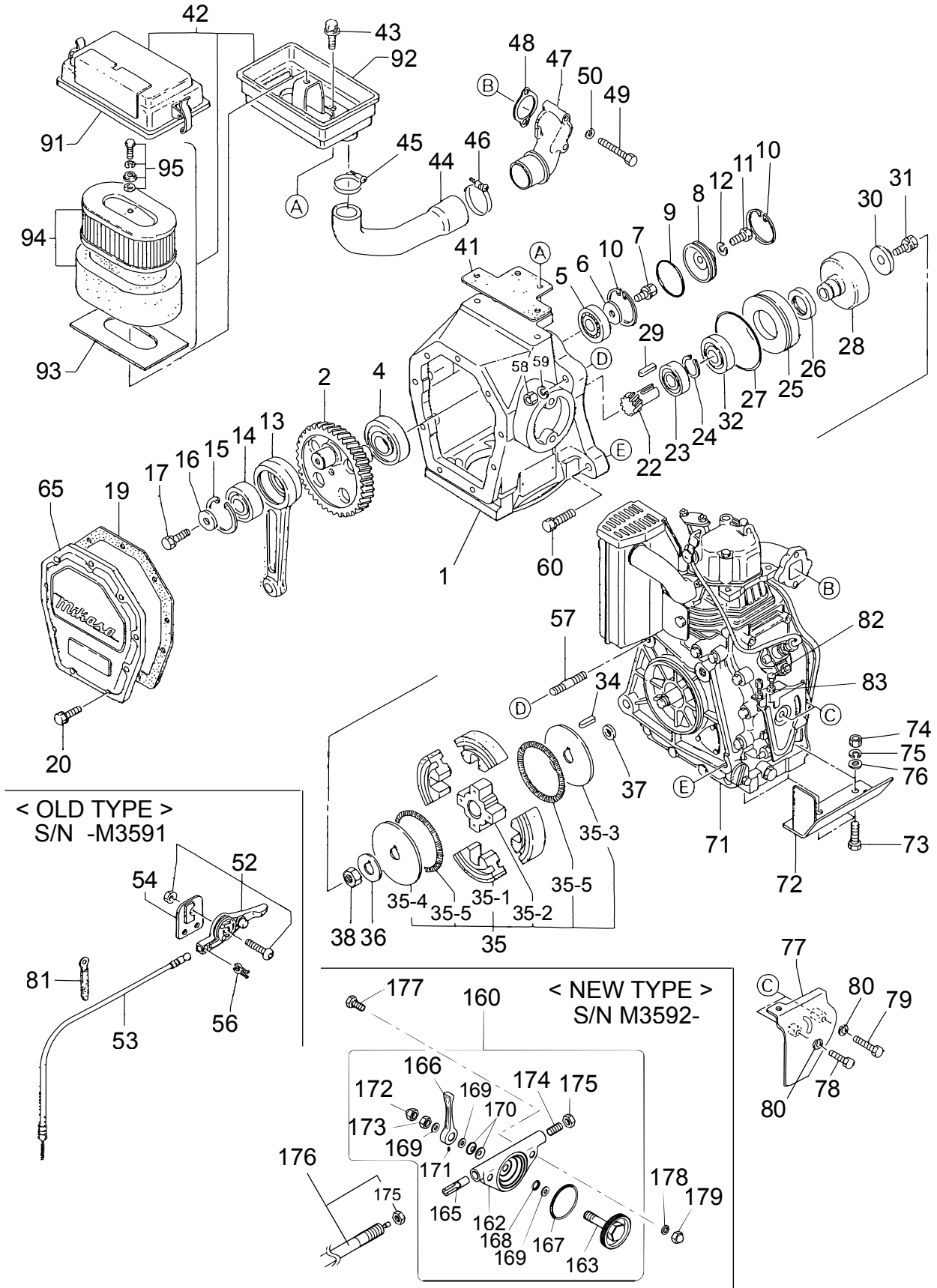

CRANK CASE & ENGINE

\*\* 3HD

\*\*

REF NO.	PART NO.	PART NAME	Q' TY	MRK	MK2	REMARKS
71	9144-10008	ENGINE AY L48EE-DRM(MT)	1	XX	SS!SD	*2 H2145-/JP
71	9144-10003	ENGINE AY L40ADRM	1		SS!SD	FOR EXP
71	9144-10025	ENGINE AY L48V6L EPA(MT)	1		SX	FOR MQ
72	3713-35100	UNDER PROTECTOR/MT76D, 86D	1		!3713-35101	-H2239
72	3713-35101	UNDER PROTECTOR/MT-D/48	1	OX		H2240-
73	0012-11040	BOLT 10X40 H	2			
74	0203-10080	NUT M10	2			
75	0302-10250	SW M10	2			
76	0311-10160	PW M10	1			
77	3714-48020	LINK PROTECTOR /MT-76, 86D	1		SS!3714-48021	#2 -2144
77	3714-48021	LINK PROTECTOR/MT-76D, 86D	1	OX		*2 H2145-
78	0012-00630	BOLT 6X30	1			
79	0012-00635	BOLT 6X35	1			
80	0302-06150	SW M6	2			
81	160260-78700	CLAMP, WIRE	2			
82	114250-66440	BOLT, ADJUSTING	1			ENGINE PART
83	26756-060002	LOCK NUT M 6 PLATED	1			ENGINE PART
91	3710-10030	BODY CP, AIR CLEANER/MT-D	1			
92	3710-10042	BACK PLATE, AIR CLEANER/MT	1			
93	3710-10050	SEAT, AIR CLEANER /MT-D	1		SX	
94	3710-10060	ELEMENT AY, AIR CLEANER/MT	1			
95	3710-10070	BOLT AY, AIR CLEANER/MT-D	1			
160	3629-10060	THROTTLE LEVER AY /MT-55	1	XX		INCL. 162-174
162	3623-41550	THROTTLE BODY /MT-55	1	XX		M3592-
163	3629-10090	THROTTLE, GEAR CP, W/BOLT	1	XX		M3592-
165	3624-55620	SLIDER /MT-55	1	XX		M3592-
166	3624-55630	THROTTLE LEVER /MT-55	1	XX		M3592-
167	0501-00450	O-RING G-45	1	XX		M3592-
168	0502-00100	O-RING P-10	1	XX		M3592-
169	0311-10160	PW M10	3	XX		M3592-
170	0339-10070	CONICAL SPRING WASHER	2	XX	!!0321-10180	M3592-
170	0321-10180	CONICAL SPRING WASHER M10	2			
171	0962-06006	SOCKET HEAD SCREW 6X6	1	XX		M3592-
172	0221-31008	CAP NUT M10	1	XX		M3592-
173	0204-10060	NUT M10, H=6	1	XX		M3592-
174	0962-08020	SOCKET HEAD SCREW 8X20	1	XX		M3592-
175	0204-08050	NUT M8, H=5	2	XX		M3592-
176	9561-00057	THROTTLE WIRE V390-510	1	XX		M3592-
177	0012-20620	BOLT 6X20 T	2	XX		M3592-
178	0302-06150	SW M6	2	XX		M3592-
179	0221-30605	CAP NUT M6	2	XX		M3592-

MT-76D

3HE0

GUIDE CYLINDER & FOOT / ガイドシリンダー&フット

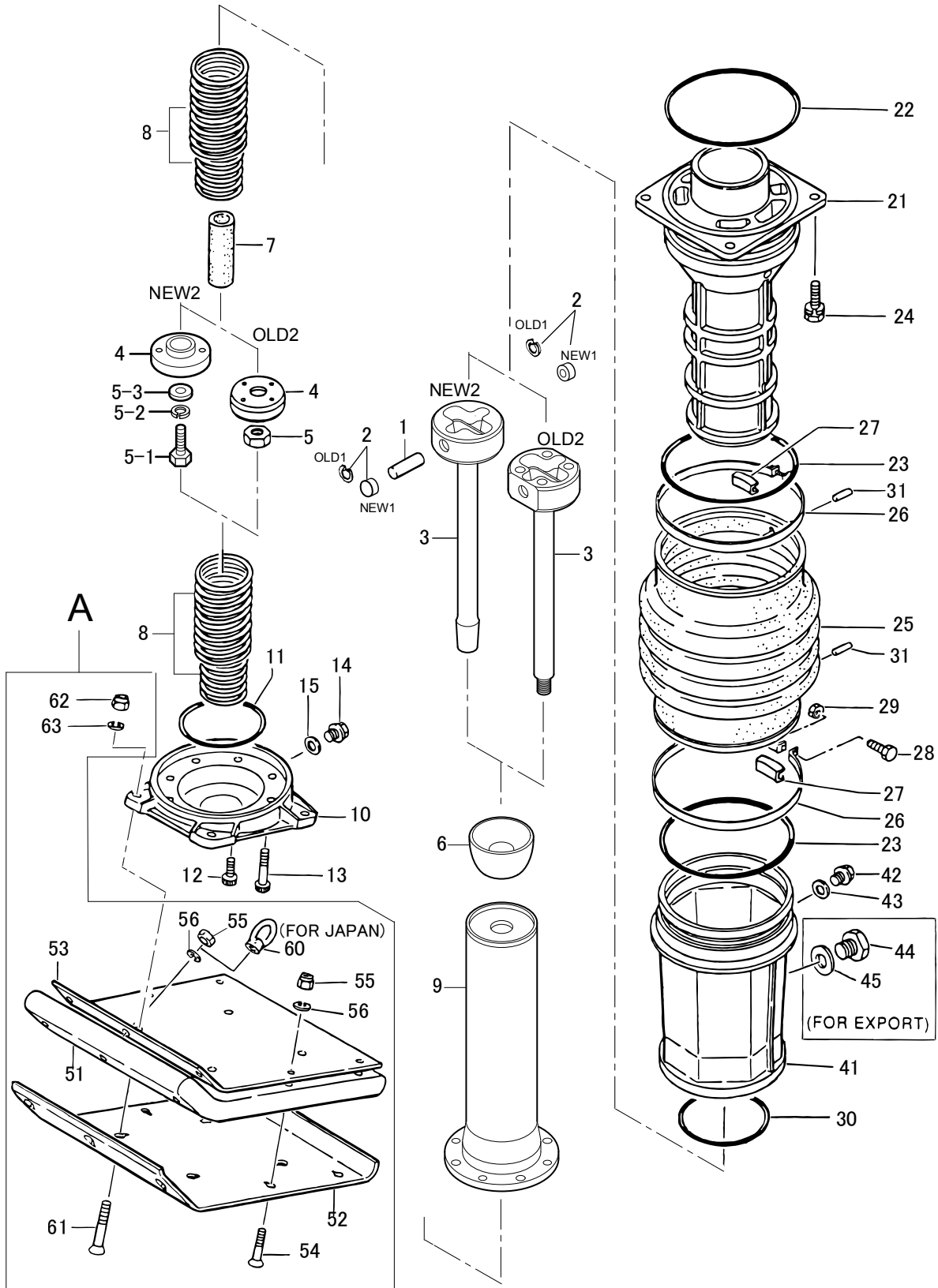



## GUIDE CYLINDER &amp; FOOT

\*\* 3HE

\*\*

REF NO.	PART NO.	PART NAME	Q' TY	MRK	MK2	REMARKS
A	3669-10020	FOOT AY 285 M4B/S80/MTX70	1			EXP IN. 51-63
A	3669-10020	FOOT AY 285 M4B/S80/MTX70	1			JPN
1	3524-23290	PISTON PIN	1			
2	0801-00150	STOP RING R-15	2			#4
2	3634-57870	PISTON PIN PLUG/MT	2	AD		*4 M3475-
3	3553-34300	PISTON ROD /MT-63W	1		!R00095	#1
3	3553-38690	PISTON ROD /MT-63W	1	XX	!R000175	*1 G1772-
3	3613-44360	PISTON ROD/MT-72, 63	1	XO		*4 M3475- #6
3	3713-45560	PISTON ROD / MT-76D	1	XX		*6 P4311-
4	3554-47240	PISTON END /MT-63W	1		!R00095	#1
4	3554-52340	PISTON END/MT-63W, 4HOLE	1	XX		*1 G1772- #6
4	3714-59690	PISTON END/MT-76D, 2HOLE	1	XX		*6 P4311-
5	0201-16130	NUT M16, P1.5	1			#1
5	0201-18150	NUT M18, P1.5	1	XX		*1 G1772- #6
5 -1	0011-21230	BOLT 12X30 T P1.5	1	XX		*6 P4311-
5 -2	0302-12300	SW M12	1	XX		*6 P4311-
5 -3	9524-04790	WASHER 13306	1	XX		*6 P4311-
6	3554-47250	STOPPER, UPPER /MT-63W	1			
7	3554-47260	STOPPER, LOWER /MT-63W	1			
8	3713-35250	MAIN SPRING /MT-76D	2			
9	3553-34310	SPRING CYLINDER /MT-63W	1			
10	3552-13000	FOOT PLATE 16 /MT-63W	1			
11	0501-00900	O-RING G-90	1			
12	0015-21020	SOCKET HEAD BOLT 10X20 T	4			
13	0015-21040	SOCKET HEAD BOLT 10X40 T	4			
14	9534-05270	PLUG 1/4X14 13L	1			
15	9534-05260	PACKING 1/4 (CU)	1			
21	3552-13010	GUIDE CYLINDER /MT-63W	1			
22	0502-01500	O-RING P-150	1			
23	0509-31500	O-RING JAS03150	2			
24	0022-11035	BOLT 10X35 H, SW	4			
25	3540-10010	BELLOWS, ORANGE/MT-70V, 63W	1			
26	3543-36352	BELLOWS CLAMP (1.6T) 171D	2			
27	3544-42340	BAND GUIDE, BELLOWS /MT68	2			
28	0012-20840	BOLT 8X40 T	2			
29	0203-08060	NUT M8	2			
30	0501-00950	O-RING G-95	1			#7
30 -1	0502-00950	O-RING P-95	1	XX		*7 -R5440
31	3544-46170	PIN 6D-8.5L	2			
41	3551-13950	PROTECTION SLEEVE/MT-72FW	1		!R000216	JP, #7, -R5440
41	3551-19020	SLEEVE/72FW, 65HE, P/JP, EXP	1	XX		JP*7, R-5441-
41	3551-13960	PROTECTION SLEEVE/MT-72FW	1		!R000211	FOR EXP, #7
41 -1	3551-19030	PROTECTION SLEEVE72FW/EXP	1	XX		EXP*7, R5441-
42	9534-05270	PLUG 1/4X14 13L	1			
43	9534-05260	PACKING 1/4 (CU)	1			
44	9590-10150	LEVEL GAUGE, PLUG TYPE	1		!3664-60300	FOR EXP
45	9534-04670	COPPER PACKING 17X25.5X1	1			FOR EXP
54	0016-11051	SUNK HEAD BOLT 10X55 H	7			
55	0227-11012	NYLON NUT M10	6			FOR DOM
55	0227-11012	NYLON NUT M10	7			FOR EXP
56	0302-10250	SW M10	7			
60	9590-10413	EYE NUT M10	1			FOR DOM
61	0016-11253	SUNK HEAD BOLT 12X65 H	4			
62	0227-11214	NYLON NUT M12	4			
63	0302-12300	SW M12	4			

MT-76D

( OLD S/N -M3591 )

TANK & HANDLE / タンク&ハンドル

3JN0

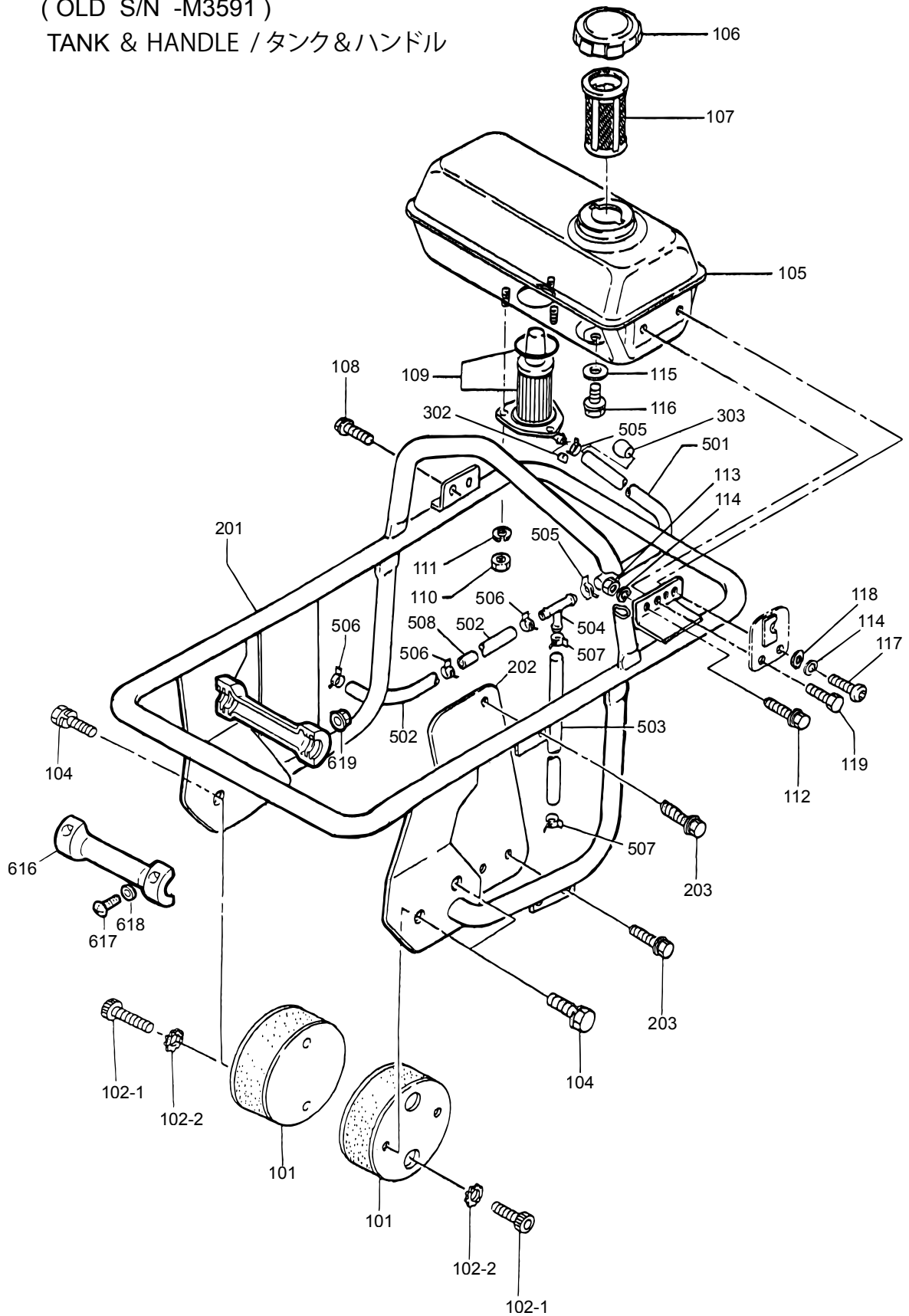

## TANK &amp; HANDLE

\*\* 3JN

\*\*

REF NO.	PART NO.	PART NAME	Q' TY	MRK	MK2	REMARKS
101	3513-19900	SHOCK ABSORBER	2			
102 -1	0015-21020	SOCKET HEAD BOLT 10X20 T	4			
102 -2	0331-21009	TOOTHED LOCK WASHER B M10	4			
104	0022-11020	BOLT 10X20 H, SW	4			
105	3711-13650	FUEL TANK /MT-76D, 86D	1	DC		#5 -M3591
105	3711-18200	FUEL TANK /MT-76D, 86D NEW	1	XX		*5 M3592-
106	043-04300-15	FUEL TANK CAP CP	1			E/G PARTS
107	9544-06010	STRAINER (#110)	1			
108	0024-10815	BOLT 8X15 H, SW, PW	3	QC		#3
108	0024-10815	BOLT 8X15 H, SW, PW	2	QC		*3, #5 -M3591
108	0024-10815	BOLT 8X15 H, SW, PW	4			*5 M3592-
109	183254-55120	STRAINER ASSY, FUEL	1			E/G ATTACH.
110	0203-06050	NUT M6	3			
111	0302-06150	SW M6	3			
112	0012-10815	BOLT 8X15 H	2	QC		#3
112	0012-10815	BOLT 8X15 H	1	DC		*3, #5 -M3591
113	0203-08060	NUT M8	1	DC		#5 -M3591
114	0302-08200	SW M8	2	DC		#5 -M3591
115	9534-05750	PACKING 10. 5D-17D-2T	1			
116	9534-05800	FLANGE PLUG PF1/8	1			
117	0091-10011	SOCKET HEAD SCREW 8X20	1	DC		#3
117	0091-10016	SOCKET HEAD SCREW 8X15	1	DC		*3, #5 -M3591
118	0311-08160	PW M8	1	DC		*3, #5 -M3591
119	0022-10815	BOLT 8X15 H, SW	1	DC		*3, #5 -M3591
201	3711-13560	HANDLE /MT-76D, 86D	1	DC	!R000199	#5 -M3591
201	3711-18190	HANDLE /MT-76D, 86D NEW	1	XX		*5 M3592-
202	3714-48010	SIDE PROTECTOR /MT76D, 86D	1			
203	0024-10815	BOLT 8X15 H, SW, PW	3			
302	9534-06200	PROTECTION CAP	1			E/G ATTACH.
303	9534-05740	PLASTIC CAP VC12/76D	1			EXP.
501	183666-59331	PIPE, FULE DRAIN	1			E/G ATTACH.
502	183250-59051	PIPE, FUEL OIL	1			E/G ATTACH.
503	114654-59070	PIPE, FUEL RETURN	1			E/G ATTACH.
504	114284-59710	JOINT	1			E/G ATTACH.
505	124766-59050	CLAMP 11. 5	2			E/G ATTACH.
506	106990-44660	BAND, HOSE 12. 5	3			E/G ATTACH.
507	124722-59050	CLAMP 9	2			E/G ATTACH.
508	183250-59040	PIECE	1			E/G ATTACH.
616	9552-00052	ROLLER, W/PIN, MT	2	AD	SS!9552-00053	
617	0910-05025	SCREW 5X25	4	AD		
618	0311-05080	PW M5	4	AD		
619	0226-10505	FLANGE NUT M5 H	4	AD		

MT-76D  
TANK & HANDLE / タンク&ハンドル  
( NEW S/N M3592- )

3JN2

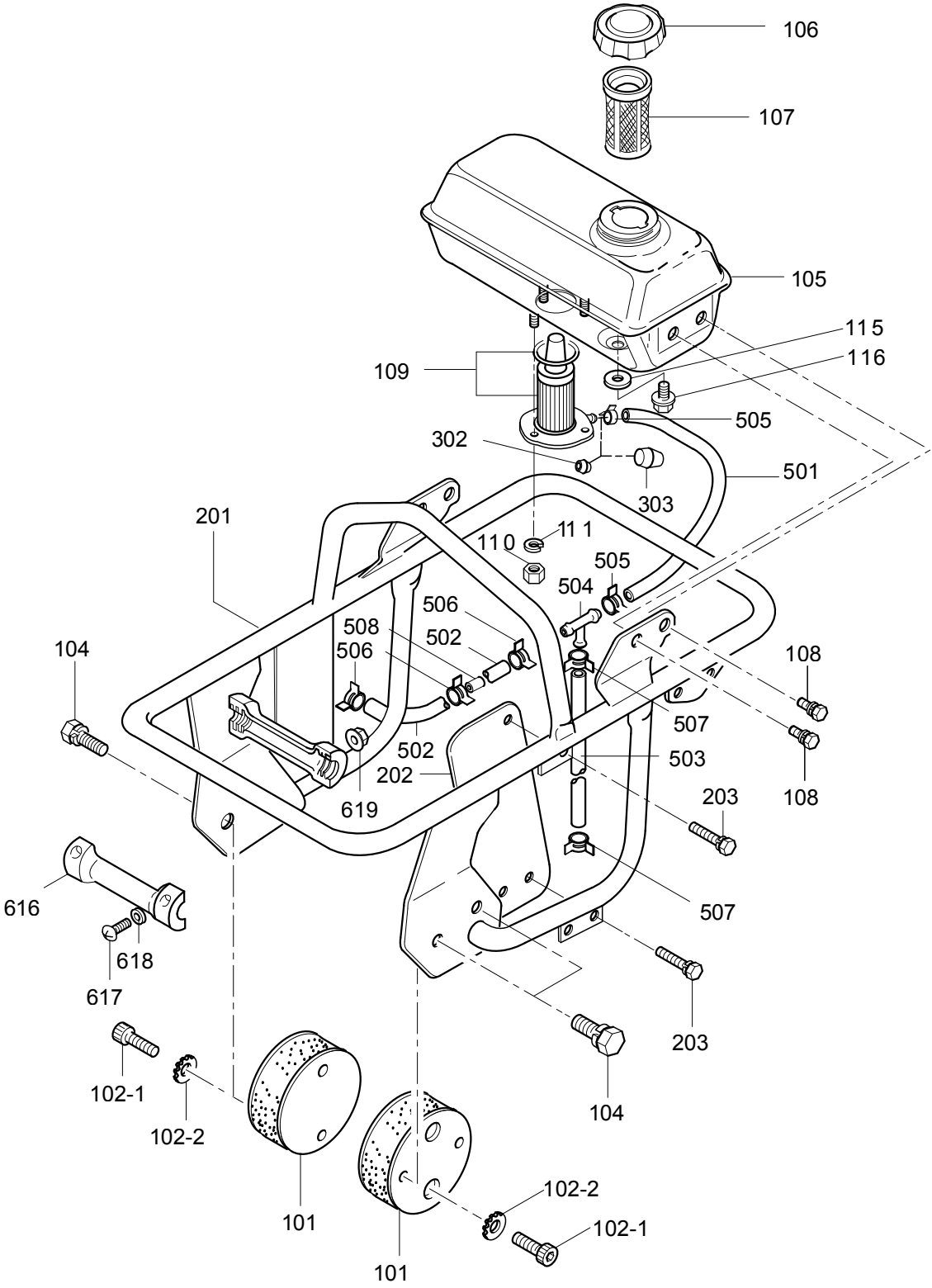

## TANK &amp; HANDLE

\*\* 3JN

\*\*

REF NO.	PART NO.	PART NAME	Q' TY	MRK	MK2	REMARKS
101	3513-19900	SHOCK ABSORBER	2			
102 -1	0015-21020	SOCKET HEAD BOLT 10X20 T	4			
102 -2	0331-21009	TOOTHED LOCK WASHER B M10	4			
104	0022-11020	BOLT 10X20 H, SW	4			
105	3711-13650	FUEL TANK /MT-76D, 86D	1	DC		#5 -M3591
105	3711-18200	FUEL TANK /MT-76D, 86D NEW	1	XX		*5 M3592-
106	043-04300-15	FUEL TANK CAP CP	1			E/G PARTS
107	9544-06010	STRAINER (#110)	1			
108	0024-10815	BOLT 8X15 H, SW, PW	3	QC		#3
108	0024-10815	BOLT 8X15 H, SW, PW	2	QC		*3, #5 -M3591
108	0024-10815	BOLT 8X15 H, SW, PW	4			*5 M3592-
109	183254-55120	STRAINER ASSY, FUEL	1			E/G ATTACH.
110	0203-06050	NUT M6	3			
111	0302-06150	SW M6	3			
112	0012-10815	BOLT 8X15 H	2	QC		#3
112	0012-10815	BOLT 8X15 H	1	DC		*3, #5 -M3591
113	0203-08060	NUT M8	1	DC		#5 -M3591
114	0302-08200	SW M8	2	DC		#5 -M3591
115	9534-05750	PACKING 10. 5D-17D-2T	1			
116	9534-05800	FLANGE PLUG PF1/8	1			
117	0091-10011	SOCKET HEAD SCREW 8X20	1	DC		#3
117	0091-10016	SOCKET HEAD SCREW 8X15	1	DC		*3, #5 -M3591
118	0311-08160	PW M8	1	DC		*3, #5 -M3591
119	0022-10815	BOLT 8X15 H, SW	1	DC		*3, #5 -M3591
201	3711-13560	HANDLE /MT-76D, 86D	1	DC	!R000199	#5 -M3591
201	3711-18190	HANDLE /MT-76D, 86D NEW	1	XX		*5 M3592-
202	3714-48010	SIDE PROTECTOR /MT76D, 86D	1			
203	0024-10815	BOLT 8X15 H, SW, PW	3			
302	9534-06200	PROTECTION CAP	1			E/G ATTACH.
303	9534-05740	PLASTIC CAP VC12/76D	1			EXP.
501	183666-59331	PIPE, FULE DRAIN	1			E/G ATTACH.
502	183250-59051	PIPE, FUEL OIL	1			E/G ATTACH.
503	114654-59070	PIPE, FUEL RETURN	1			E/G ATTACH.
504	114284-59710	JOINT	1			E/G ATTACH.
505	124766-59050	CLAMP 11. 5	2			E/G ATTACH.
506	106990-44660	BAND, HOSE 12. 5	3			E/G ATTACH.
507	124722-59050	CLAMP 9	2			E/G ATTACH.
508	183250-59040	PIECE	1			E/G ATTACH.
616	9552-00052	ROLLER, W/PIN, MT	2	AD	SS!9552-00053	
617	0910-05025	SCREW 5X25	4	AD		
618	0311-05080	PW M5	4	AD		
619	0226-10505	FLANGE NUT M5 H	4	AD		







**MIKASA SANGYO CO.,LTD.**

HEAD OFFICE

NO. 4-3. 1-CHOME, SARUGAKU-CHO, CHIYODA-KU  
TOKYO, JAPAN