



SPARE PARTS MANUAL

FLEXTOOL SCARIFIER FSP-200



Applies to serial number D04-10,000 onwards

Version 1.0 (June 2022)

FOR MORE INFORMATION
CONTACT US ON **1300 353 986** OR VISIT flextool.com.au

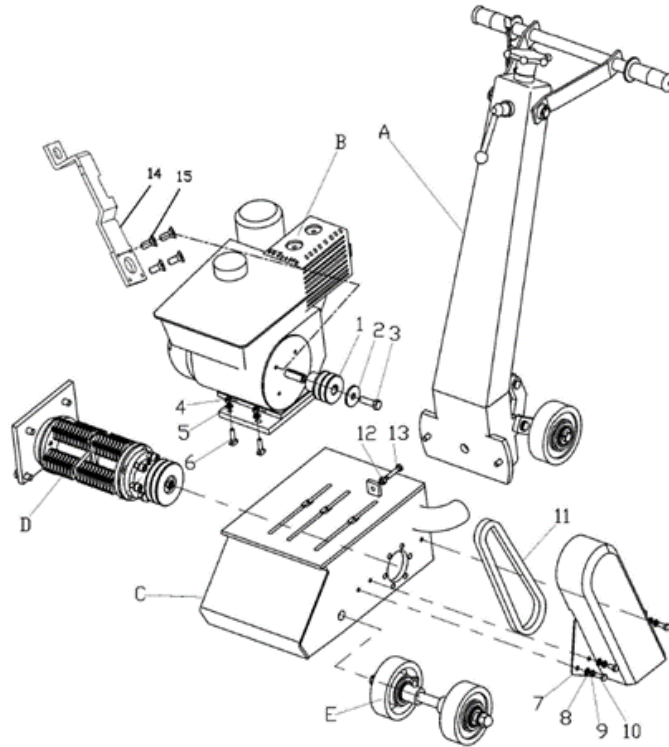

Main Assemblies (FSP-200)

Item No.	Product Code	Description	Qty	Remarks
A	NPS07635-UNIT	FLX HANDLE ASSY (SY-B-289)	1	
B	NPS01628-UNIT	HON MOTOR GX160K1 QX4.1KW (F01628)	1	
C	NPS07687-UNIT	FLX ENGINE MOUNTED PLATE (SY-JG-220-LK01)	1	
D	FT101800-UNIT	FLX SCARIFIER CAGE ASSY SUITS FPS200 (SY-B-CSC200154-0245)	1	
E	NPS07629-UNIT	FLX FRONT WHEEL ASSY (SY-B-CSC200-159)	1	
1	NPS07636-UNIT	FLX PULLEY (SY-ZZ-200-0035)	1	
2	NPS07234-UNIT	FLX RETAINER M8 (SY-ZZ-CSC-ZZ246)	1	
3	NPS07637-UNIT	FLX SCREW (SY-ZZ-CSC-ZZ247)	1	
4	NPS00406-UNIT	FLX LOCK NUT 8MM (SY-BM-M08-M055)	4	
5	NPS07228-UNIT	FLX WASHER FLAT M8 (SY-BP-08-P012)	4	
6	NPS07638-UNIT	FLX SCREW M8X50 (SY-LS-T-850)	4	
7	NPS07639-UNIT	FLX BELT COVER (SY-YD-220-DZ19)	1	
8	NPS07228-UNIT	FLX WASHER FLAT M8 (SY-BP-08-P012)	3	
9	NPS00404-UNIT	FLX SPRING WASHER 8MM (SY-BD-08-D005)	3	
10	NPS00403-UNIT	FLX BOLT M8 X 20MM HEX (SY-BN-0820-N107)	3	
11	NPS00313-UNIT	FLX V BELT AX29 FSP200 (E09-10011 AFTER) (SY-R-140-C328)	2	
	NPS00312-UNIT	FLX V BELT AX28 FSP200 (UP TO E08-10010) (CSC-G20001005)	2	
12	NPS07640-UNIT	FLX HEX NUT M10 (SY-BM-M10-M019)	1	
13	NPS07641-UNIT	FLX HEX HEAD SCREW M10X30 (SY-BS-1030-S060)	1	
14	NPS02891-UNIT	FLX LIFTING HOOK (SY-BJ-180-BC12)	1	
15	NPS07211-UNIT	FLX BOLT M8X20 (SY-BN-0820-N081)	4	

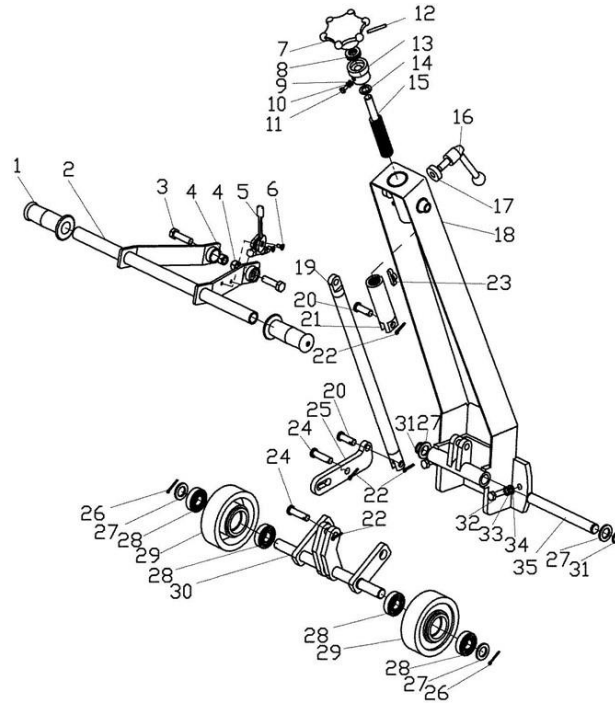

Handle And Rear Wheels (FSP-200)

Item No.	Product Code	Description	Qty	Remarks
1	NPS01089-UNIT	FLX HANDLE GRIP (SY-YT-260-TB04)	2	
2	NPS07642-UNIT	FLX HANDLE (SY-L-XBJ02)	1	
3	NPS07643-UNIT	FLX HEX HEAD SCREW M12X60 (SY-BN-1260-N078)	2	
4	NPS07253-UNIT	FLX LOCK NUT M12 (SY-BM-M12-M065)	2	
5	NPS07644-UNIT	FLX THROTTLE CONTROL + CABLE ASSY (SY-YD-220-DX44)	1	
6	NPS07645-UNIT	FLX SOCKET HEAD SCREW M6X12 (SY-BS-0612-S347)	2	
7	NPS07646-UNIT	FLX KNOB (SY-BT-200-TJ43)	1	
8	NPS07647-UNIT	FLX BEARING (SY-ZC-8103-CU26)	1	
9	NPS07267-UNIT	FLX WASHER FLAT M8 (SY-BP-06-P010)	1	
10	NPS07268-UNIT	FLX WASHER SPRING M6 (SY-BD-06-D004)	1	
11	NPS07281-UNIT	FLX BOLT M6X12 (SY-BS-0612-S353)	1	
12	NPS07648-UNIT	FLX PIN (SY-BY-0530-YZ06)	1	
13	NPS07649-UNIT	FLX BEARING HOLDER (SY-YC-MPJ-CT96)	1	
14	NPS07650-UNIT	FLX WASHER (SY-BP-15-P001)	1	
15	NPS07652-UNIT	FLX SCREW (SY-YS-220-SS19)	1	
16	NPS07653-UNIT	FLX LOCK SCREW (SY-YS-200-SU11)	1	
17	NPS07654-UNIT	FLX RUBBER (SY-YJ-XJD-JD07)	1	
18	NPS07655-UNIT	FLX HANDLE (SY-BJ-C200-SC09)	1	
19	NPS07656-UNIT	FLX SCREW (SY-BJ-C200-SC10)	1	
20	NPS07657-UNIT	FLX PIN (SY-ZZ-CSC-ZZ248)	2	
21	NPS07658-UNIT	FLX SLEEVE (SY-ZZ-CSC-ZZ165)	1	
22	NPS07632-UNIT	FLX PIN (SY-ZZ-CSC-ZZ245)	4	
23	NPS07659-UNIT	FLX LOCK NUT (SY-ZZ-CSC-ZZ159)	1	
24	NPS07660-UNIT	FLX PIN (SY-ZZ-CSC-ZZ249)	2	
25	NPS07661-UNIT	FLX CONNECTING PLATE (SY-JG-180-QY21)	1	
26	NPS07632-UNIT	FLX PIN (SY-ZZ-CSC-ZZ245)	2	
27	NPS07633-UNIT	FLX WASHER FLAT M20 (SY-BP-20-P006)	6	
28	NPS07631-UNIT	FLX BEARING 6204ZZ (SY-ZC-6204-CU11)	4	
29	NPS07630-UNIT	FLX REAR WHEEL (SY-YL-200-LZ37)	2	
30	NPS07634-UNIT	FLX FIXING PLATE (SY-BJ-C200-SC08)	1	
31	NPS07662-UNIT	FLX RETAINING RING (SY-YQ-20-QD48)	2	
32	NPS07641-UNIT	FLX HEX HEAD SCREW M10X30 (SY-BS-1030-S060)	2	
33	NPS07684-UNIT	FLX SPRING WASHER M10 (SY-BD-10-D006)	2	
34	NPS07212-UNIT	FLX WASHER FLAT M10 (SY-BP-10-P043)	2	
35	NPS07663-UNIT	FLX SHAFT (SY-YZ-1235-ZD56)	1	

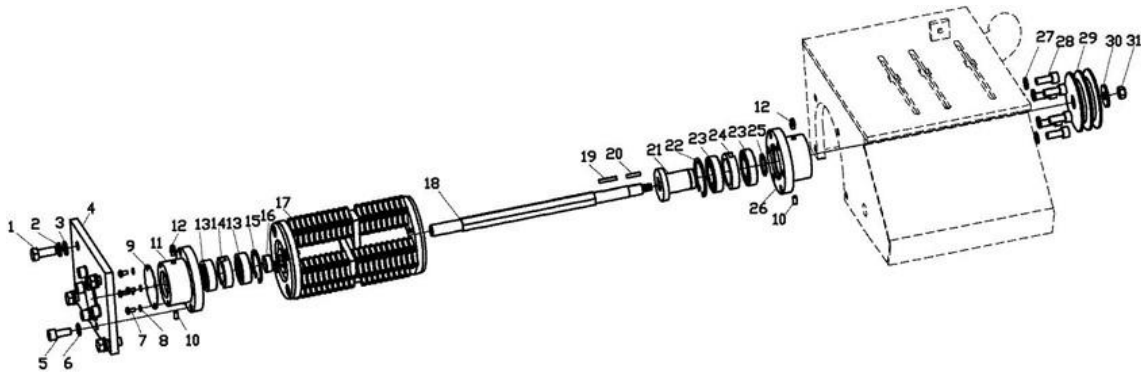

Drive Shaft and Cage (FSP-200)

Item No.	Product Code	Description	Qty	Remarks
1	NPS07218-UNIT	FLX BOLT M12X30 (SY-BN-1230-N023)	4	
2	NPS07217-UNIT	FLX WASHER SPRING M12 (SY-BD-12-D007)	4	
3	NPS07255-UNIT	FLX WASHER FLAT M12 (SY-BP-12-P005)	4	
4	NPS07664-UNIT	FLX PLATE (SY-JG-S200-S221)	1	
5	NPS07665-UNIT	FLX SOCKET HEAD SCREW M10X25 (SY-BN-1025-N002)	6	
6	NPS07684-UNIT	FLX SPRING WASHER M10 (SY-BD-10-D006)	6	
7	NPS07666-UNIT	FLX SCREW M5X10 (SY-BS-0510-S275)	4	
8	NPS07667-UNIT	FLX SPRING WASHER M5 (SY-BD-05-D003)	4	
9	NPS07668-UNIT	FLX RETAINING RING (SY-JG-S200-S220)	1	
10	NPS07669-UNIT	FLX SOCKET HEAD SCREW M6X12 (SY-BN-0612-N101)	2	
11	NPS07671-UNIT	FLX BEARING HOLDER (SY-ZZ-CSC-ZZ265)	1	
12	NPS07672-UNIT	FLX OIL CUP (SY-YY-250-YB73)	2	
13	NPS07673-UNIT	FLX BEARING 6303 (SY-ZS-6303-SK10)	2	
14	NPS07674-UNIT	FLX RETAINING RING (SY-ZZ-CSC-ZZ152)	1	
15	NPS07675-UNIT	FLX RETAINING RING (SY-YQ-47-QD22)	1	
16	NPS07676-UNIT	FLX RETAINING RING (SY-ZZ-CSC-ZZ155)	1	
17	FT101800-UNIT	FLX SCARIFIER CAGE ASSY SUITS FPS200 (SY-BCSC200154-0245)	1	
18	NPS00279-UNIT	FLX HEX DRIVE SHAFT SCARIFIER FPS200 (SY-ZZ-220-ZZ219)	1	
19	NPS07677-UNIT	FLX KEY (SY-BP-0530-P123)	1	
20	NPS07528-UNIT	FLX KEY STEEL 5MM X 20MM (SY-BP-0520-P109)	1	
21	NPS07678-UNIT	FLX SLEEVE (SY-ZZ-CSC-ZZ154)	1	
22	NPS07679-UNIT	FLX RETAINING RING (SY-YQ-55-QD23)	1	
23	NPS07680-UNIT	FLX BEARING 6006 (SY-ZS-6006-SK01)	2	
24	NPS07681-UNIT	FLX RETAINING RING (SY-ZZ-CSC-ZZ153)	1	
25	NPS07682-UNIT	FLX RETAINING RING (SY-YQ-30-QD52)	1	
26	NPS07683-UNIT	FLX SLEEVE (SY-ZZ-CSC-ZZ156)	1	
27	NPS07684-UNIT	FLX SPRING WASHER M10 (SY-BD-10-D006)	6	
28	NPS07685-UNIT	FLX SOCKET HEAD SCREW M10X25 (SY-BN-1025-N002)	6	
29	NPS07686-UNIT	FLX PULLEY (SY-ZZ-CSC-ZZ170)	1	
30	NPS07234-UNIT	FLX WASHER (SY-ZZ-CSC-ZZ246)	1	
31	NPS07253-UNIT	FLX LOCK NUT M12 (SY-BM-M12-M065)	1	

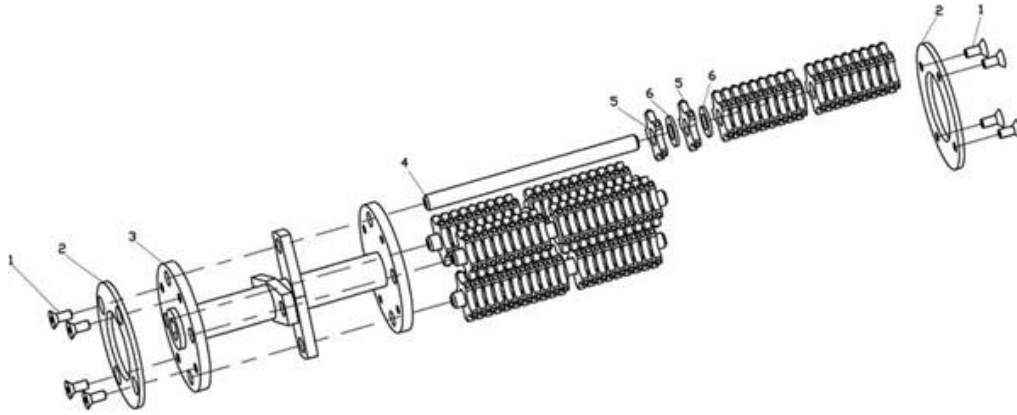

Cutter Cage (FSP-200)

Item No.	Product Code	Description	Qty	Remarks
1	NPS07211-UNIT	FLX BOLT M8X20 (SY-BN-0820-N081)	8	
2	NPS07688-UNIT	FLX PLATE (SY-JG-S200-S223)	2	
3	NPS07689-UNIT	FLX DRUM FRAME (SY-B-CSC200-157-0253)	1	
4	NPS07690-UNIT	FLX SHAFT (SY-YZ-250-ZD20)	4	
5	NPS07691-UNIT	FLX CUTTER (SY-BJ-18-ZH02)	80	
6	NPS07692-UNIT	FLX WASHER (SY-BP-14-P060)	80	

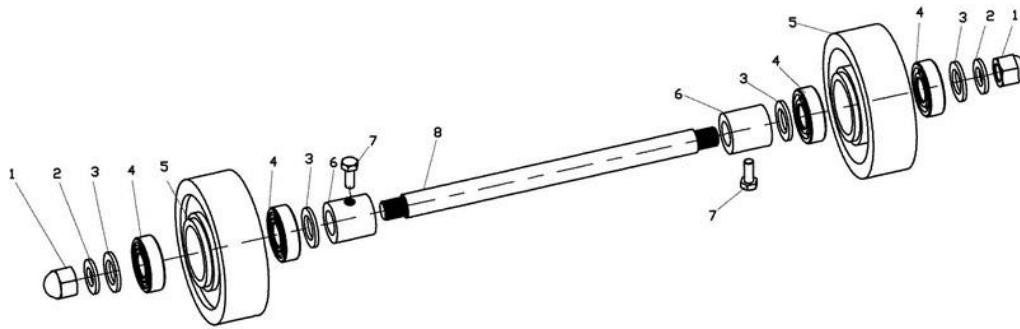

Front Wheels (FSP-200)

Item No.	Product Code	Description	Qty	Remarks
1	NPS07693-UNIT	FLX DOME NUT M16 (SY-BM-M16-M080)	2	
2	NPS07694-UNIT	FLX SPRING WASHER M16 (SY-BP-16-P002)	2	
3	NPS07633-UNIT	FLX WASHER FLAT M16 (SY-BP-20-P006)	4	
4	NPS07631-UNIT	FLX BEARING 6204ZZ (SY-ZC-6204-CU11)	4	
5	NPS07695-UNIT	FLX WHEEL (SY-YL-5050-LZ17)	2	
6	NPS07696-UNIT	FLX RETAINING RING (SY-ZZ-CSC-ZZ171)	2	
7	NPS07697-UNIT	FLX HEX HEAD SCREW M8X20 (SY-BN-0820-N014)	2	
8	NPS07698-UNIT	FLX SHAFT (SY-ZZ-CSC-ZZ162)	1	



Parchem Construction Supplies Pty Ltd

1956 Dandenong Road, Clayton VIC 3168, Australia

Phone: 1300 353 986

flextool.com.au

ABN 80 069 961 968

This manual summarises our best knowledge of the product based on the information available at the time of publication. You should read this manual carefully and consider the information in the context of how the product will be used. Our responsibility for products sold is subject to our standard terms and conditions of sale.

DISCLAIMER:

Any advice, recommendation, information, assistance or service provided by us in this manual is given in good faith and is believed by us to be appropriate and reliable. However, any advice, recommendation, information, assistance or service provided by us is provided without liability or responsibility PROVIDED THAT the foregoing shall not exclude, limit, restrict or modify the right entitlements and remedies conferred upon any person or the liabilities imposed upon us by any condition or warranty implied by Commonwealth, State or Territory Act or ordinance void or prohibiting such exclusion limitation or modification. The product can be expected to perform as indicated in this manual so long as operation and operational procedures of the individual products are followed as recommended in this manual.

Design and technical specifications may be subject to changes.

© This publication is copyright. All rights are reserved. Flextool is a registered trade mark of Parchem Construction Supplies Pty Ltd.

FOR MORE INFORMATION

CONTACT US ON 1300 353 986 OR VISIT flextool.com.au