

OPERATING INSTRUCTIONS

FLEXTOOL TUFFTRUK[™] EB500



Version 1.0 (November 2022)

This page is intentionally blank.

EB500 TuffTruk Walk-Behind Mini Dumper

Safety Information	4-7
Specifications (Mini Dumper)	8
Specifications (Electric Motor)	9
Noise And Vibration	10
Dimensions.....	11
General Information.....	12
Components	13-14
Inspection	15-16
Operation	17-20
Maintenance	21-27
Error Codes	29-30
Troubleshooting	31
Electronic Component Locator	33
Wiring Diagram.....	34

DO NOT operate or service the equipment before reading the entire manual. Safety precautions should be followed at all times when operating this equipment. Failure to read and understand the safety messages and operating instructions could result in injury to yourself and others.



SAFETY MESSAGES

The four safety messages shown below will inform you about potential hazards that could injure you or others. The safety messages specifically address the level of exposure to the operator and are preceded by one of four words: **DANGER, WARNING, CAUTION** or **NOTICE**.

SAFETY SYMBOLS

! DANGER

Indicates a hazardous situation which, if not avoided, **WILL** result in **DEATH** or **SERIOUS INJURY**.

! WARNING

Indicates a hazardous situation which, if not avoided, **COULD** result in **DEATH** or **SERIOUS INJURY**.

! CAUTION

Indicates a hazardous situation which, if not avoided, **COULD** result in **MINOR** or **MODERATE INJURY**.

NOTICE

Addresses practices not related to personal injury.

GENERAL SAFETY

! CAUTION

- **NEVER** operate this equipment without proper protective clothing, shatterproof glasses, respiratory protection, hearing protection, steel-toed boots and other protective devices required by the job or city and state regulations.



- Avoid wearing jewelry or loose fitting clothes that may snag on the controls or moving parts as this can cause serious injury.

- **NEVER** operate this equipment when not feeling well due to fatigue, illness or when under medication. 

- **NEVER** operate this equipment under the influence of drugs or alcohol.



- **ALWAYS** clear the work area of any debris, tools, etc. that would constitute a hazard while the equipment is in operation.

- No one other than the operator is to be in the working area when the equipment is in operation.

- **DO NOT** use the equipment for any purpose other than its intended purposes or applications.

NOTICE

- This equipment should only be operated by trained and qualified personnel 18 years of age and older.
- Whenever necessary, replace nameplate, operation and safety decals when they become difficult to read.
- Manufacturer does not assume responsibility for any accident due to equipment modifications. Unauthorized equipment modification will void all warranties.

SAFETY INFORMATION

■ **NEVER** use accessories or attachments that are not recommended by Flextool for this equipment. Damage to the equipment and/or injury to user may result.

■ **ALWAYS** know the location of the nearest fire extinguisher.



■ **ALWAYS** know the location of the nearest first aid kit.



■ **ALWAYS** know the location of the nearest phone or **keep a phone on the job site**. Also, know the phone numbers of the nearest **ambulance, doctor** and **fire department**. This information will be invaluable in the case of an emergency.



TUFFTRUK SAFETY

DANGER

■ **NEVER** operate the equipment in an explosive atmosphere or near combustible materials. An explosion or fire could result causing severe **bodily harm or even death**.



WARNING

■ Accidental starting can cause severe injury or death. **ALWAYS** place the ON/OFF switch in the OFF position.

■ **NEVER** disconnect any **emergency or safety devices**. These devices are intended for operator safety. Disconnection of these devices can cause severe injury, bodily harm or even death. Disconnection of any of these devices will void all warranties.

■ **NEVER** approach power lines with any part of the TuffTruk unless all local, state/provincial and federal (OSHA) required safety precautions have been taken. Use extreme caution when approaching high voltage power lines.

CAUTION

■ **ALWAYS** inspect the surface over which you will travel. Look for holes, drop-offs and obstacles. Look for rough and weak spots on docks, ramps or floor.

■ **ALWAYS** Look for oil spills, wet spots and slippery surfaces. Look for soft soil, deep mud and standing water. Watch for anything that might make you lose control or cause the TuffTruk to tip over.

■ **ALWAYS** clear away trash and debris. Pick up anything that might puncture the tires.

■ **ALWAYS** make sure aisles, ramps, doorways and passages are clear.

■ **ALWAYS** plan your work. Make sure you know where you will make your pickups, dumps and turns. Before you take a load, know where you will place it.

■ **NEVER** travel down a slope with a **full load**. The possibility exists of tipping.

■ **DO NOT** operate the TuffTruk on unsafe haul roads, load areas, and dump areas.

■ **DO NOT** operate TuffTruk on excessive slopes with a grade higher than 25° (45%), forward and backward.

■ **DO NOT** operate TuffTruk on extremely uneven surfaces.

■ **NEVER** allow people to ride inside the tub/bucket.

■ **DO NOT** operate the TuffTruk at excessive speeds. Reckless operation may cause accidents and severe injury. Slow down when approaching people, wet areas, and going up and down grades. It is the responsibility of the operator to adjust speed, as necessary, depending on the conditions of the road or path.

■ Forward travel speed should not exceed 4 mph (6.44 km/h). Reverse travel speed should not exceed 1.5 mph (2.42 km/h).

■ **ALLOW** extra time to stop when operating the TuffTruk on wet surfaces or loosely graded materials.

■ **DO NOT** dump materials from bucket/tub while the TuffTruk is moving.



NOTICE

- **ALWAYS** ensure TuffTruk is **securely** placed on appropriate blocks or jackstands when performing maintenance.
- When parking on a slope, position the TuffTruk at a right angle to a slope.
- When filling or dumping **DO NOT** exceed payload capacity of TuffTruk.
- **ALWAYS** be aware of traveling conditions. Reduce load if necessary.
- **DO NOT** activate dump mechanism (tub/bucket) if TuffTruk is facing a down hill slope.
- **DO NOT** stand in front or along side the TuffTruk when discharging a load.
- **ALWAYS** block the TuffTruk with appropriate blocks when leaving the TuffTruk parked on a slope.
- To prevent unexpected loss of control, **DO NOT** start engine on a sloping surface.
- Ensure that the speed control levers works freely and returns to the stop position. **DO NOT** start electric motor unless speed control linkage is working properly.
- Make sure that the tires are inflated to the manufacturer's recommended tire pressure.
- **NEVER** operate the TuffTruk with bad or worn tires. **ALWAYS** replace defective tires with new ones.
- Avoid sudden stops and starts and changes in direction. Operate the controls smoothly. **DO NOT** jerk the steering or any other controls.
- **NEVER** attempt to engage the controls except from the operator's position.
- **NEVER** operate or tow the TuffTruk in traffic or on public roads.
- **ALWAYS** keep the machine in proper running condition.
- Fix damage to machine and replace any broken parts immediately.
- The entire TuffTruk (tub, shroud, wheels, etc.) should be cleaned after every use. Make sure there is no buildup of concrete, grease, oil or debris on the machine.

- **ALWAYS** store equipment properly when it is not being used. Equipment should be stored in a clean, dry location out of the reach of children and unauthorized personnel.

BATTERY SAFETY

DANGER

- **DO NOT** drop the battery. There is a possibility that the battery will explode.
- **DO NOT** expose the battery to open flames, sparks, cigarettes, etc. The battery contains combustible gases and liquids. If these gases and liquids come into contact with a flame or spark, an explosion could occur.



WARNING

- **ALWAYS** wear safety glasses when handling the battery to avoid eye irritation. The battery contains acids that can cause injury to the eyes and skin.
- Use well-insulated gloves when picking up the battery.
- **ALWAYS** keep the battery charged. If the battery is not charged, combustible gas will build up.
- **DO NOT** charge battery if frozen. Battery can explode. When frozen, warm the battery to at least 61°F (16°C).
- **ALWAYS** recharge the battery in a well-ventilated environment to avoid the risk of a dangerous concentration of combustible gases.
- If the battery liquid (dilute sulfuric acid) comes into contact with **clothing or skin**, rinse skin or clothing immediately with plenty of water.
- If the battery liquid (dilute sulfuric acid) comes into contact with **eyes**, rinse eyes immediately with plenty of water and contact the nearest doctor or hospital to seek medical attention.



SAFETY INFORMATION

⚠ CAUTION

- **ALWAYS** disconnect the **NEGATIVE battery terminal** before performing service on the equipment.
- **ALWAYS** keep battery cables in good working condition. Repair or replace all worn cables.
- **ALWAYS** use proper lifting procedures when removing the batteries from the machine. Batteries are quite heavy. Bodily injury may result if proper lifting procedures are not employed.

LIFTING SAFETY

⚠ CAUTION

- **NEVER** allow any person or animal to stand underneath the equipment while lifting.

NOTICE

- When lifting of the TuffTruk is required, attach lifting straps or chains to designated lifting points only.
- Use lifting straps or chains of adequate lifting capacity.
- **DO NOT** lift machine to unnecessary heights.
- **NEVER** lift the equipment while the engine is running.
- **ALWAYS** use ramps capable of supporting the weight of the TuffTruk and the operator to load and unload the TuffTruk.

TRANSPORTING SAFETY

NOTICE

- **ALWAYS** shutdown unit before transporting.
- When transporting of the TuffTruk is required, place the TuffTruk on a flat bed truck or equivalent and tie down securely.
- **ALWAYS** make sure all tie-downs are in place and the tub/bucket is completely lowered in the flat (horizontal) position and securely latched.

- Place **chock blocks** underneath wheel to prevent rolling.
- **DO NOT** use the TuffTruk to transport people.
- When transporting the TuffTruk on a truck or trailer, know the overall height to avoid contacting overhead obstructions such as bridges and power lines. Check the truck and ramp capacities.

ENVIRONMENTAL SAFETY/DECOMMISSIONING

NOTICE

Decommissioning is a controlled process used to safely retire a piece of equipment that is no longer serviceable. If the equipment poses an unacceptable and unrepairable safety risk due to wear or damage or is no longer cost effective to maintain (beyond life-cycle reliability) and is to be decommissioned (demolition and dismantlement), be sure to follow rules below.

- Contact your country's Department of Public Works or recycling agency in your area and arrange for proper disposal of any electrical components, waste or oil associated with this equipment.
- When the life cycle of this equipment is over, remove battery (if equipped) and bring to appropriate facility for lead reclamation. Use safety precautions when handling batteries that contain sulfuric acid.
- When the life cycle of this equipment is over, it is recommended that the unit frame and all other metal parts be sent to a recycling center.



Metal recycling involves the collection of metal from discarded products and its transformation into raw materials to use in manufacturing a new product.

Recyclers and manufacturers alike promote the process of recycling metal. Using a metal recycling center promotes energy cost savings.

SPECIFICATIONS (MINI DUMPER)

Table 1. Specifications (TuffTruk)	
Model	EB500
Maximum Weight Capacity	529 lbs. (239.9 kg)
Maximum Payload Weight	1,100 lbs. (500 kg)
Bucket/Tub Capacity	12.0 cu. ft. Water Level (.44 cu. yd.)
Bucket/Tub Capacity (Option)	7.0 cu. ft. Water Level (.26 cu. yd.)
Bucket/Tub Material	Polyethylene
Drive	24 VDC Electric Motor
Speed Forward	Up to 4.0 mph. (6.43 km/h)
Speed Reverse	Up to 1.5 mph. (2.42 km/h)
Steering Radius Outside Dia.	56 in. (1422 mm)
Brake System	Dead Man Handle
Dump Control	Mechanical Dump and Manual Return
Discharge Height	2.0 in. (50.8 mm)
Gradeability Slope (Up/Down)	25°
Gradeability Lateral (Side-Side)	6°
Battery Type	12V 27 AGM Deep Cell, 550 CCA @ 0°C 77Ah@5 Hr./89Ah@20 Hr. Capacity@25A 158 minutes
Battery (LxWxH)	12.05 x 6.84 x 9.32 in. (306 x 174 x 237 mm)
Battery Weight	64 lbs (29 kg)
Pneumatic Tires	16 x 6.50 x 8 (406 x 165 x 203 mm)
Pneumatic Tire Pressure	28 PSI (193 Kpa)

SPECIFICATIONS (ELECTRIC MOTOR)

Table 2. Electric Motor Specifications	
Model	AMER
Type	Permanent Magnet DC Electric Motor
Speed Control Method	Curtis 1228 Controller
Starting Method	Electric
Max RPM (No Load)	2900
Input Voltage	24 VDC
Wattage	750 X 2 (1500W)
Poles	4
Protection Class	IP: 44
Insulation Class	F
IEC Duty Cycle	S3 15%
Dimension Approx. (L x W x H)	6.4 X 7.81 X 5.7 in. (164 X 200 X 145 mm)
Dry Net Weight Approx.	22 lbs. (10 kg)

Table 3. Noise and Vibration Emissions	
Model	EB500
Guaranteed ISO 11201:2010 Based Sound Pressure Level at Operator Station in dB(A) ^a	56
Guaranteed ISO 3744:2010 Based Sound Power Level in dB(A) ^b	76
Hand-Arm Vibration Per ISO 5349-1:2001 in $m/s^2 \sum A(8)$	2.5

a. With an uncertainty factor K of 2.5 dB (A) included per Note 1 in section 7.2.1 of EN 12649::2008+A1:2011

b. With an uncertainty factor K of 1.5 dB (A) included per Note 1 in section 7.2.1 of EN 12649::2008+A1:2011

NOTES:

1. *Sound pressure and power levels are "A" weighted measures per ISO 3744:2010. They are measured with the operating condition of the machine which generates the most repeatable but highest values of the sound levels. Under normal circumstances, the sound level will vary depending on the condition of the material being worked upon.*
2. *The vibration level indicated is the vector sum of the RMS (root mean Square) values of amplitudes on each axis, standardized to an 8-hour exposure period, and obtained using the operating condition of the machine that generates the most repeatable but highest values in accordance with the applicable standards for the machine.*
3. *Per EU Directive 2002/44/EC, the daily exposure action value for hand/arm vibration is $2.5 m/s^2 \sum A(8)$. The daily exposure limit value is $5 m/s^2 \sum A(8)$.*

DIMENSIONS

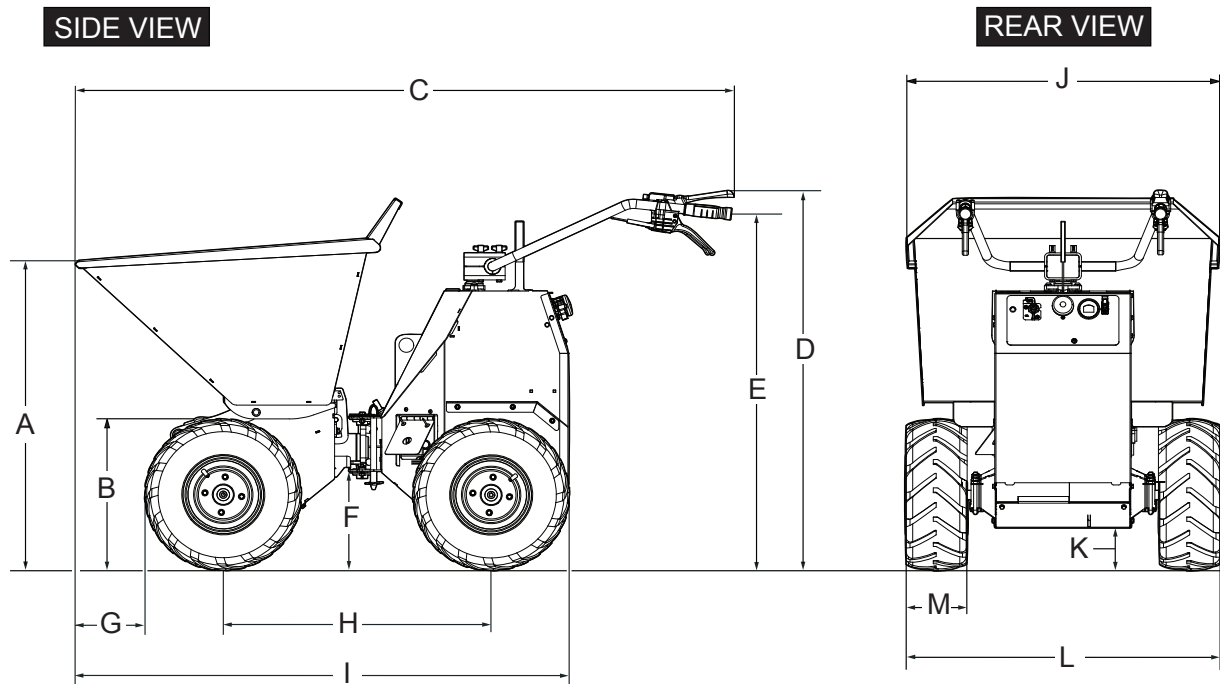

TOP VIEW

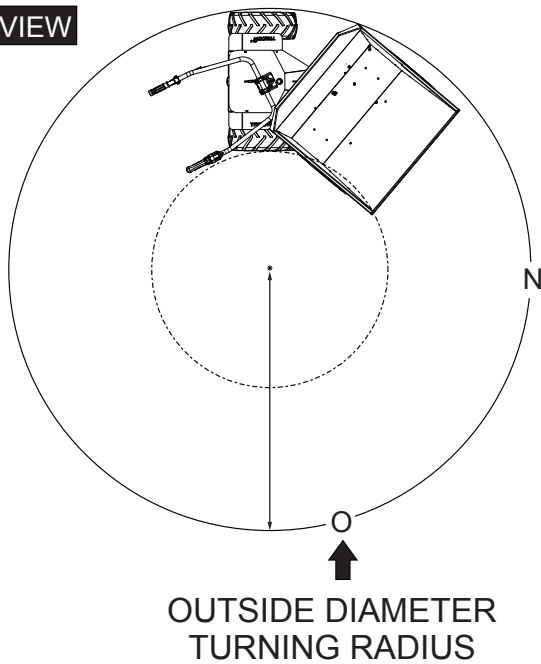

Table 4. Dimensions

Reference Letter	Dimension in. (mm)
A	34.20 (869)
B	16.50 (419)
C	70.30 (1,786)
D	41.90 (1,064)
E	39.20 (995)
F	10.9 (277)
G	7.40 (188)
H	28.60 (726)
I	53.0 (1,340)
J	33.40 (848)
K	5.50 (140)
L	33.40 (848)
M	6.37 (162)
N	56.0 (1,22)

Figure 1. EB500 Dimensions

GENERAL INFORMATION

The Flextool Walk-Behind TuffTruk EB500 **electric mini dumpers** are intended for job site cleanup and material transport.

The Mini Dumper is equipped with a 2.0 in. (50.8 mm) dump height which provides clearance and enables the operator to maneuver over any form height.

A low center of gravity has been incorporated into the design which provides added safety when manoeuvring the Mini Dumper in tight areas.

The maximum **forward** speed of the **electric** driven Mini Dumper is rated at 4.0 mph. (6.43 km/h). Maximum **reverse** speed is 1.5 mph. (2.42 km/h).

For ease of dumping, a manual hand lever control is provided. Maximum weight capacity (payload) is 990 lbs. (500 kg). Multiple lift points have been provided to allow for easy access of a forklift when lifting is required.

ELECTRIC POWER PLANT

The Mini Dumper is equipped with two 750 watt permanent magnet 24 VDC electric motors connected in series that produce a total output of 1500 watts. For additional information, reference Table 2.

MOTOR CONTROLLER

The electric models are equipped with a sealed heavy-duty permanent motor controller, Curtis Model 1229 Speed Controller (ECU). This controller provides functional and directional control of the TuffTruk Mini Dumper. It allows the Mini Dumper to start and stop or move in a forward or reverse direction.

This controller can detect a wide variety of faults or error conditions. Diagnostic information can be obtained by interfacing with the Curtis Model 3100R Gauge Display. This gauge will display error codes as referenced in the maintenance section of this manual.

In addition, this controller has the capability of interfacing with Controller Area Network (CAN bus) applications.

AUXILIARY CONNECTIONS (OPTIONS)

There are two auxiliary connection ports on the unit, they are labeled AUX 1 and AUX 2. If desired they can be used for horn and light additions.

DIAGNOSTIC GAUGE

This electric model is equipped with a diagnostic gauge. This gauge will display system error codes. Reference maintenance section in this manual for further details.

WARNING

All operators must have training before operating the TuffTruk Mini Dumper. For your safety, warnings are on the machine and in this manual. Failure to obey these warnings can cause severe injury or even death.

CAUTION



DO NOT attempt to operate the TuffTruk Mini Dumper until the Safety Information, General Information, and Inspection sections of this manual have been **read and thoroughly understood**.

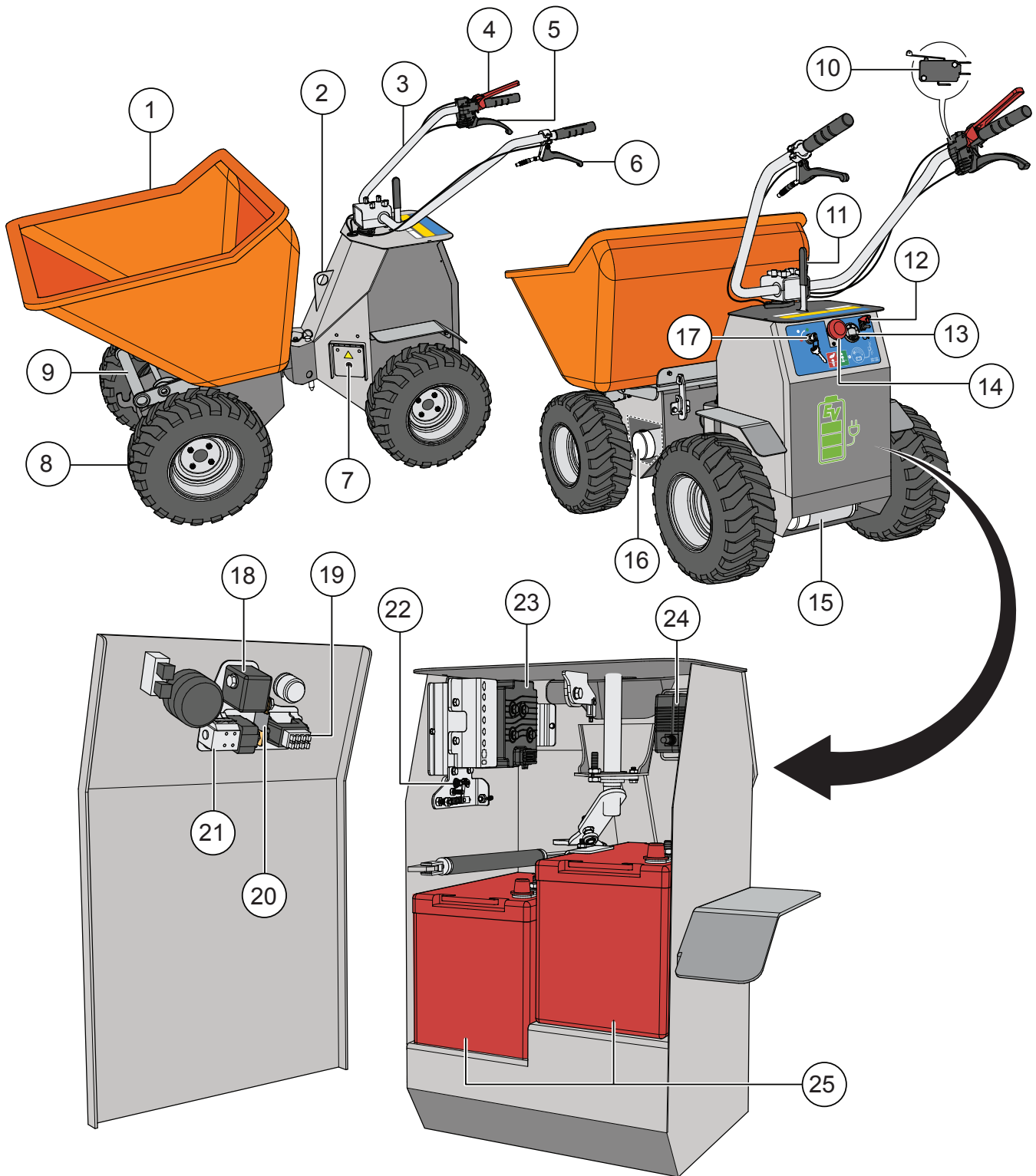

Figure 2. TuffTruk Walk-Behind Mini Dumper Components

1. **Tub or Bucket** — Used for the transportation of material. Tub holds approximately 12.0 cubic feet (0.44 cubic yards) of water.
2. **Lifting Point** — Attach a suitable lifting strap to these points when lifting of the Mini Dumper is required.
3. **Handle Bar (Steering)** — This handle bar is used to steer the Mini Dumper. When steering the Mini Dumper, use both hands and hold onto both handle bar grips.
4. **Deadman Control Lever** — **Red** handle lever, when engaged (closed) allows the use both to travel in either a forward or reverse direction. Works in conjunction with forward and reverse control levers. In addition, this lever when engaged releases the brake.
5. **Forward/Reverse Speed Control Lever** — When fully engaged, the Mini Dumper will travel at **FULL** speed in either the forward or reverse direction. When released, the Mini Dumper will **STOP**. This feature is only on the electric models.
6. **Reverse Control Lever Signal Cable** — This lever/cable is a 2-wire cable (switch) that when activated sends a +12 VDC signal (J1-10) to the motor controller indicating that the reverse travel function has been selected.
7. **Battery Charger Cable** — Plug battery charger cable plug into a 240 VAC power source.
8. **Tires** — Unit uses pneumatic tires. Reference Table 1 for tire size.
9. **Tipping Bracket Pivot Bar** — Attach this bar to the Mini Dumper frame to tip tub. Be sure to lock in place (locking levers).
10. **Deadman Microswitch** — When activated sends a +12 VDC signal (J1-3) to the motor controller to release the brake. Microswitch is located inside handle.
11. **Dump Control Lever** — Push the lever forward to place the tub in the dump position (vertical).
12. **Free-Wheel Brake Bypass Switch** — Momentary toggle switch. Allows the Mini Dumper to be moved with the electric motor brakes disengaged
13. **Battery/Diagnostic Gauge** — Uses a Curtis Model 3100R Gauge Display. Displays battery voltage and fault codes. CAN bus compatible.
14. **Emergency Stop Switch** — In the event of an emergency, **push** this button to shutdown the electric motor.
15. **Electric Motor (Front)** — Uses a 24 VDC, 750 watt electric motor.
16. **Electric Motor (Rear)** — Uses a 24 VDC, 750 watt electric motor.
17. **Ignition/Key** — When activated allows the unit to be started.
18. **Contactor** — Heavy duty relay used for the switching of the ON and OFF +12 VDC power required for the Curtis Model 1229 motor controller. Works in conjunction with the contactor solenoid.
19. **Fuse Box** — Provides protection for various electrical circuits. Reference wiring diagram in the manual.
20. **Contactor Fuse** — 100 amp fuse that provides protection for the electric motor.
21. **Contactor Solenoid (Coil)** — When energized (coil), allows +12 VDC power to be transferred to the Curtis Model 1229 motor controller via the K1-1 and K1-2 contacts.
22. **5K OHM Potentiometer** — Provides signal for speed sensor.
23. **Motor Speed Controller** — Unit uses a Curtis Model 1229 Controller. Requires a 24 VDC input. Interfaces with CAN bus applications.
24. **Battery Charger (Electric)** — When activated, charges both 12-volt batteries.
25. **Battery** — Uses two 12 volt batteries connected in series (24 volts). Always use gloves and eye protection when handling the batteries.

BEFORE STARTING

CAUTION

NEVER disable or disconnect the **emergency stop switch**. It is provided for operator safety. Injury may result if it is disabled, disconnected or improperly maintained.

BATTERY

This unit is of negative ground **DO NOT** connect in reverse. **ALWAYS** maintain battery fluid level between the specified marks. Battery life will be shortened, if the fluid levels are not properly maintained. Add only distilled water when replenishment is necessary.

DO NOT over fill. Check to see whether the battery cables are loose. Poor contact may result in poor starting or malfunctions.

ALWAYS keep the terminals firmly tightened and coat the terminals with an approved battery terminal treatment compound. Replace battery with only recommended type battery. The battery type used in this power Mini Dumper is BCI Group 27.

The battery is sufficiently charged if the specific gravity of the battery fluid is 1.28 (at 68° F / 20°C).). If the specific gravity should fall to 1.245 or lower, it indicates that the battery is dead and needs to be recharged or replaced.

Before charging the battery with an external electric source, be sure to disconnect the battery cables.

CAUTION

ALWAYS disconnect the negative terminal **FIRST** and reconnect the negative terminal **LAST**.

Battery Cable Installation

ALWAYS be sure the battery cables (Figure 3) are properly connected to the battery terminals as shown below. The batteries are connected in series.

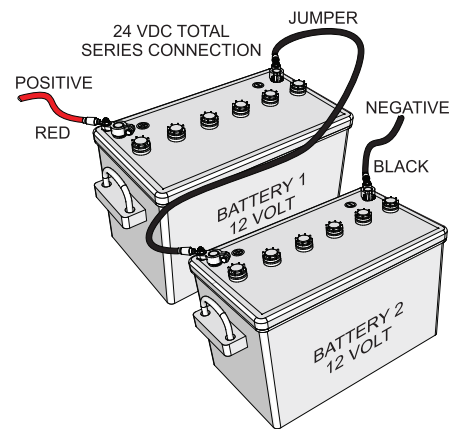

Figure 3. Battery Series Connections

When connecting battery do the following:

1. **NEVER** connect the battery cables to the battery terminals when the ignition is in the **ON** position (start).
2. Place a small amount of battery terminal treatment compound around both battery terminals. This will ensure a good connection and will help prevent corrosion around the battery terminals.

NOTICE

If the battery cable is connected incorrectly, electrical damage to the Mini Dumper will occur. Pay close attention to the polarity of the battery when connecting the battery.

CAUTION

Inadequate battery connections may cause poor starting of the TuffTruk Mini Dumper, and create other malfunctions.

TIRE CHECK

Check for **worn** or **defective** tires (Figure 4). Replace any defective or worn tires immediately.

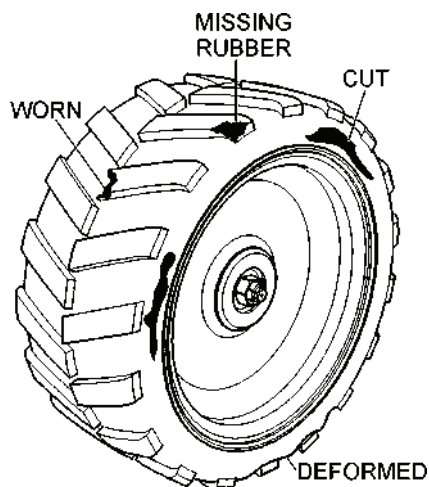

Figure 4. Tire Wear

The wheels and tires of the Mini Dumper are very important in its effective operation.

1. Check the tires regularly to make certain the lug nuts are tight.
2. Make sure tires are inflated to manufacturer's suggested tire pressure. **DO NOT** operate the Mini Dumper with bad or worn tires.

LINKAGE CHECK

Check and make sure that **all** linkages within the TuffTruk Mini Dumper are functioning correctly.

STEERING CHECK

1. Check and make sure that the Mini Dumper's steering turns freely and that there is no binding.

This section is intended to assist the operator with the initial start-up of the unit. It is extremely important that this section be read carefully before attempting to use the TuffTruk walk-behind Mini Dumper in the field. **DO NOT** use your Mini Dumper until the General Information, and Inspection sections of this manual have been **read and thoroughly understood**.



WARNING

Failure to understand the operation of the Mini Dumper could result in severe damage to the Mini Dumper or personal injury. Reference Figure 2 for the location of any components referenced in this manual.

CAUTION



NEVER operate the TuffTruk walk-behind Mini Dumper in a confined area or enclosed area structure that does not provide ample free flow of air. Gasoline models only.

STARTING THE FLEXTOOL MINI DUMPER

The following steps outline the procedure for starting the electric Mini Dumper.

1. Located on the control panel of the Mini Dumper, is the **emergency stop** button (Figure 5). Pull this button outward to start the electric motor.

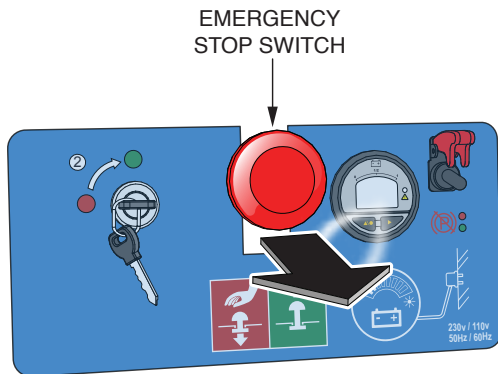

Figure 5. Emergency Stop Switch (Closed)

2. Place the ignition key (Figure 6) in the **START** position. Verify that all segments of the diagnostic gauge illuminate for 1 second and then turn off. In addition, check battery voltage level. If low, recharge batteries.

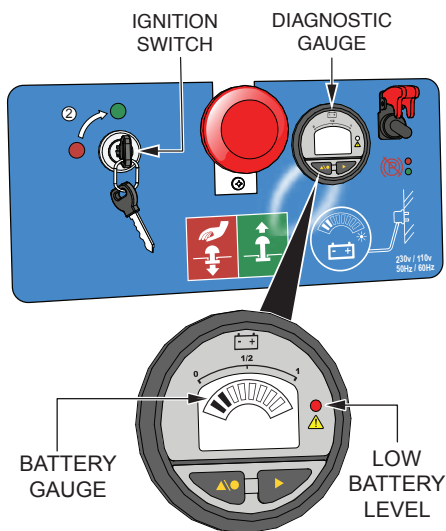

Figure 6. Ignition Key (Start)

3. With the electric motor running, fully squeeze the **RED** deadman lever (Figure 7) and hold down. When the lever is held down, a signal is sent via a microswitch to the motor controller (J1-3) to release the brake.

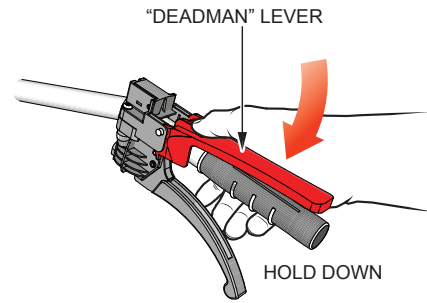

Figure 7. Deadman Lever

4. Slightly squeeze the **forward/reverse** speed control lever (Figure 8) until the Mini Dumper begins to move in a **forward** direction.

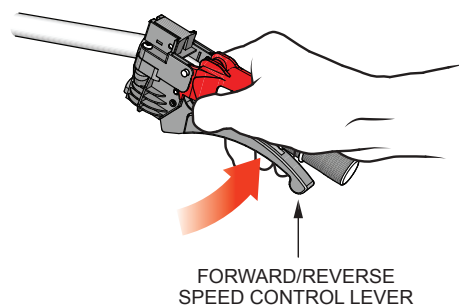

Figure 8. Forward/Reverse Speed Control Lever (Electric)

5. On the opposite side of the handle bar is the **reverse** control lever **signal cable**. This cable is a 2-wire cable that sends a signal via a switch to the motor controller (J1-10) indicating that the **reverse** travel function has been selected.
6. Squeeze the **reverse** control lever signal cable (Figure 9) and hold down.

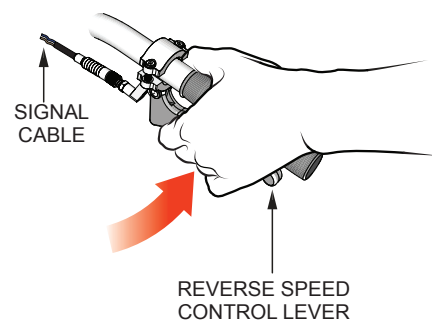

Figure 9. Reverse Control Lever Signal Cable

7. Slightly squeeze the **forward/reverse** speed control lever (Figure 8) until the Mini Dumper begins to move in a **reverse** direction.

CAUTION

Avoid sudden and quick turns. When steering, turn the handle bar slowly. **ALWAYS** face the controls when traveling.

STEERING

To steer the Mini Dumper, use the handle bar in front of the unit.

1. To turn left (Figure 10) when traveling in the forward direction, turn the handle bar clockwise.

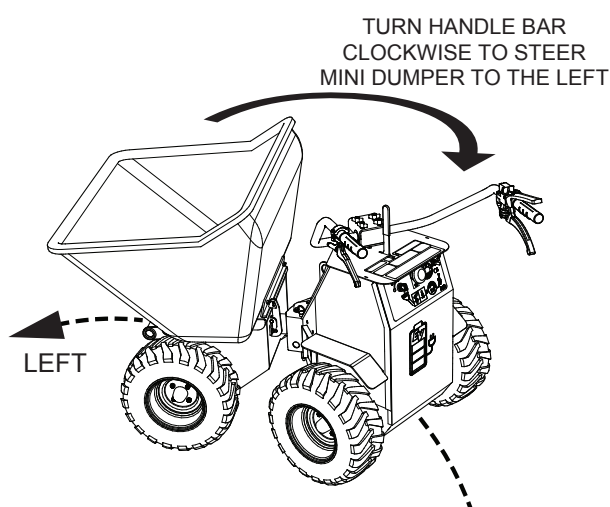

Figure 10. Steering the Mini Dumper (CW-Left)

2. To turn right (Figure 11) when traveling in the forward direction, turn the handle bar in the counterclockwise direction.

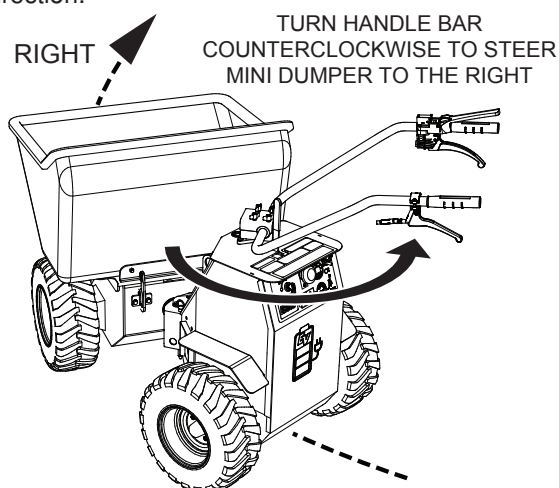

Figure 11. Steering the Mini Dumper (CCW-Right)

CAUTION

DO NOT steer the Mini Dumper left or right when traveling up or down on a grade. Travel in a straight path.

TRAVELING ON A SLOPE

1. When traveling on a slope, it is necessary to determine the grade of the path. The EB500 Mini Dumper can travel up or down slopes not exceeding 25° (Figure 12). **DO NOT** travel on steeper slopes.

To determine the % grade of your path of travel, use the formula and graph in Figure 12.

2. Lateral side to side travel cannot exceed 6°.

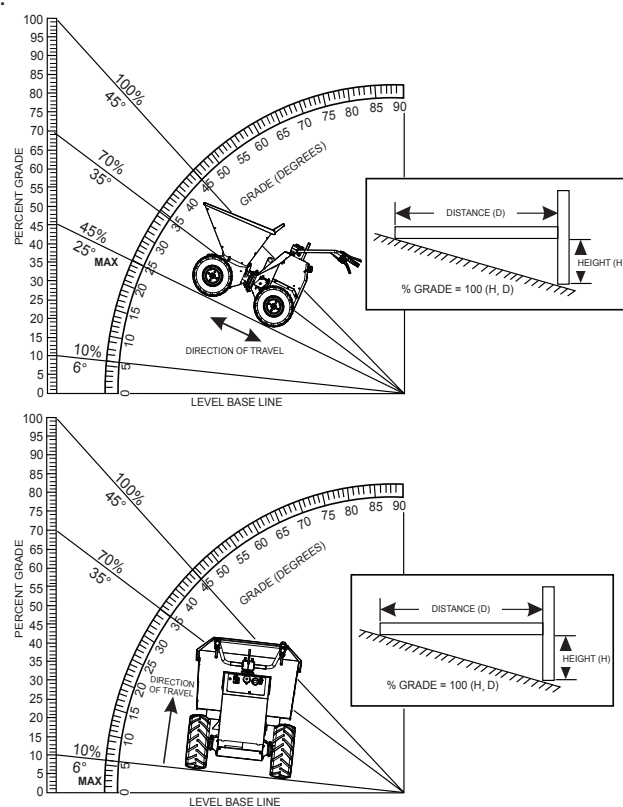

Figure 12. Determining Grade of Slope

NOTICE

The possibility of **tipping** (Figure 13A) exist when transporting heavy loads. **ALWAYS** transport heavy loads as shown in Figure 29B.

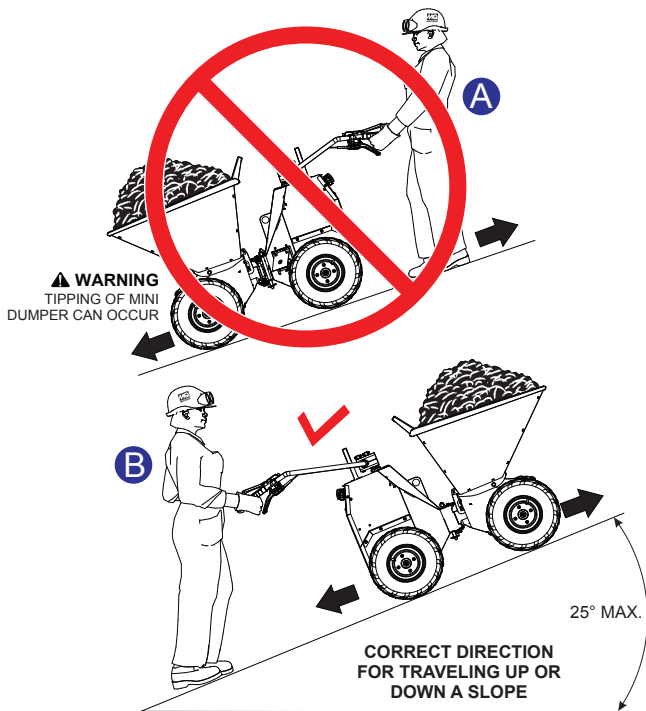

Figure 13. Slope Travel Direction

TUB (BUCKET) DUMPING

1. To place the tub in the dump position (Figure 14) pull back on the dump lever and release. The tub will automatically rotate to the vertical position and dump its contents.

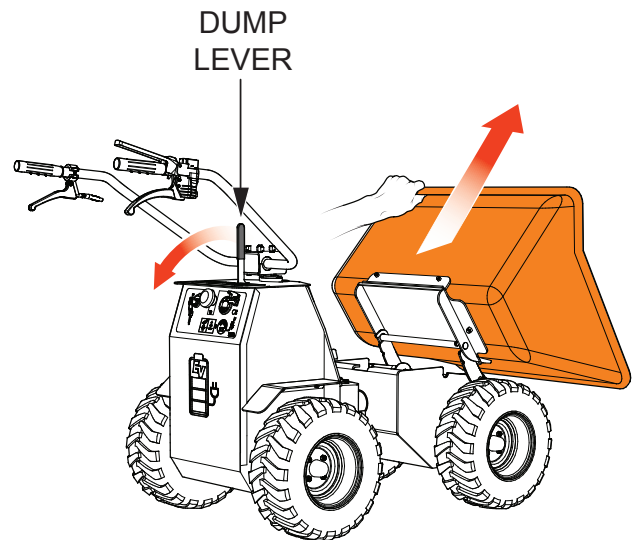

Figure 14. Tub Vertical Position

NOTICE

If the Mini Dumper is on a incline, it might be necessary to slightly push the tub upward in a forward direction so the tub can be placed in the dump position.

2. To return the tub back to the horizontal position, grab hold of the tub (Figure 15) and push down.

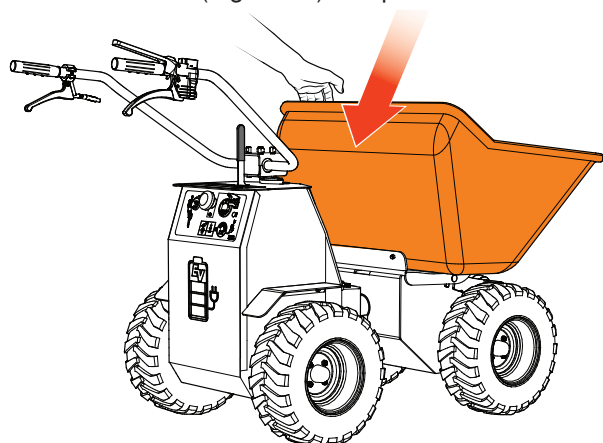

Figure 15. Tub Horizontal Position

NORMAL SHUTDOWN

1. Release the **RED** deadman lever and come to a complete stop. Brake is now set.
2. Place the ignition switch in the **OFF** position.
3. Block wheels if on a slope or incline.

EMERGENCY SHUTDOWN

1. Push the **EMERGENCY STOP** switch (Figure 16).

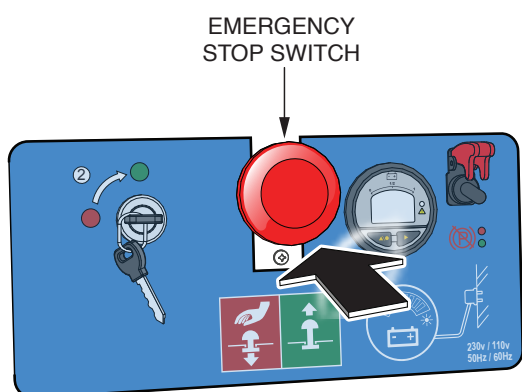

Figure 16. Emergency Stop Switch (Push)

Table 5. Mini Dumper Maintenance Schedule

Check Item	OPERATION	DAILY	Periodic Maintenance Interval			
			Every 25 Hrs	Every 50 Hrs	Every 100-125 Hrs	Every 200 Hrs
Tub	Clean	X			X	
Tub For Cracks/Deformations	Check			X		
Tires For Severe Cuts/Wear	Check	X				
Fastners	Check	X				

BATTERY CHARGER

The TuffTruk EB500 has a built-in 24 VDC battery charger. When charging of the battery is required, perform the following:

NOTICE

The battery charger installed is a Smart Charger, it can be left connected to the batteries after full charge (green light on) without harming batteries.

The charger uses minimum power in this stand-by mode (battery fully charged) and maintains the batteries at full charge and extends battery life.

1. Place the ignition switch key (Figure 17) on the **OFF** position.

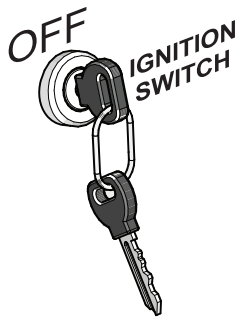

Figure 17. Ignition Switch (OFF)

2. Push the **EMERGENCY STOP** switch (Figure 18).



Figure 18. Emergency Stop Switch (Push)

3. Remove the battery charger power cable from the storage compartment as shown in Figure 19.
4. Next, connect the battery charger power cable to a 240 VAC power source.

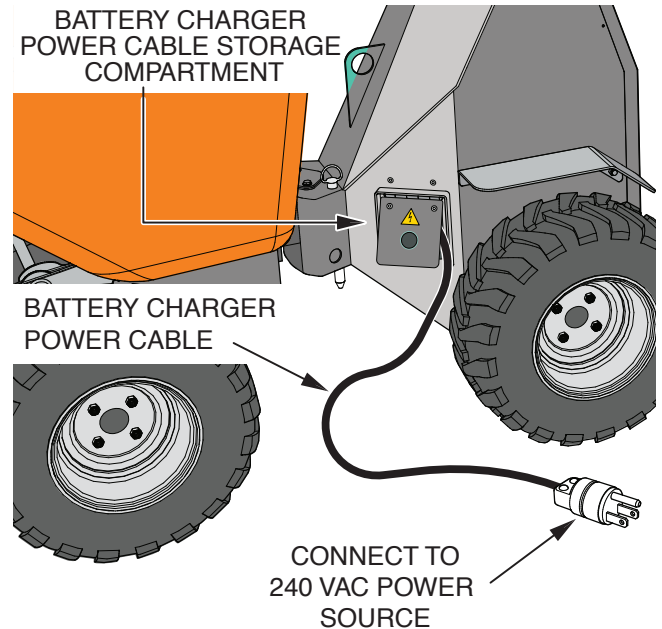

Figure 19. Battery Charger Power Cable

5. Charging of the batteries can be observed by viewing the small window (Figure 20) on the left-hand side of the battery box. The charging light is normally **ORANGE** which changes to **GREEN** when the batteries are fully charged.

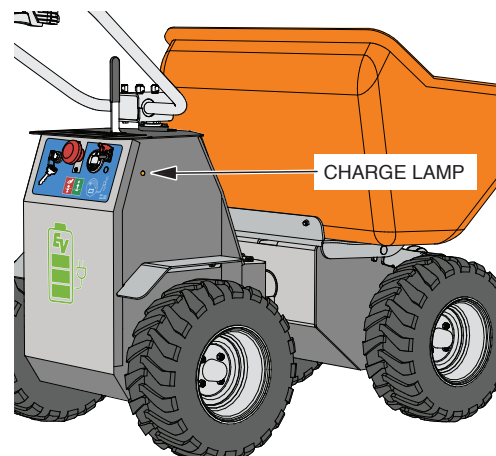

Figure 20. Charging Light

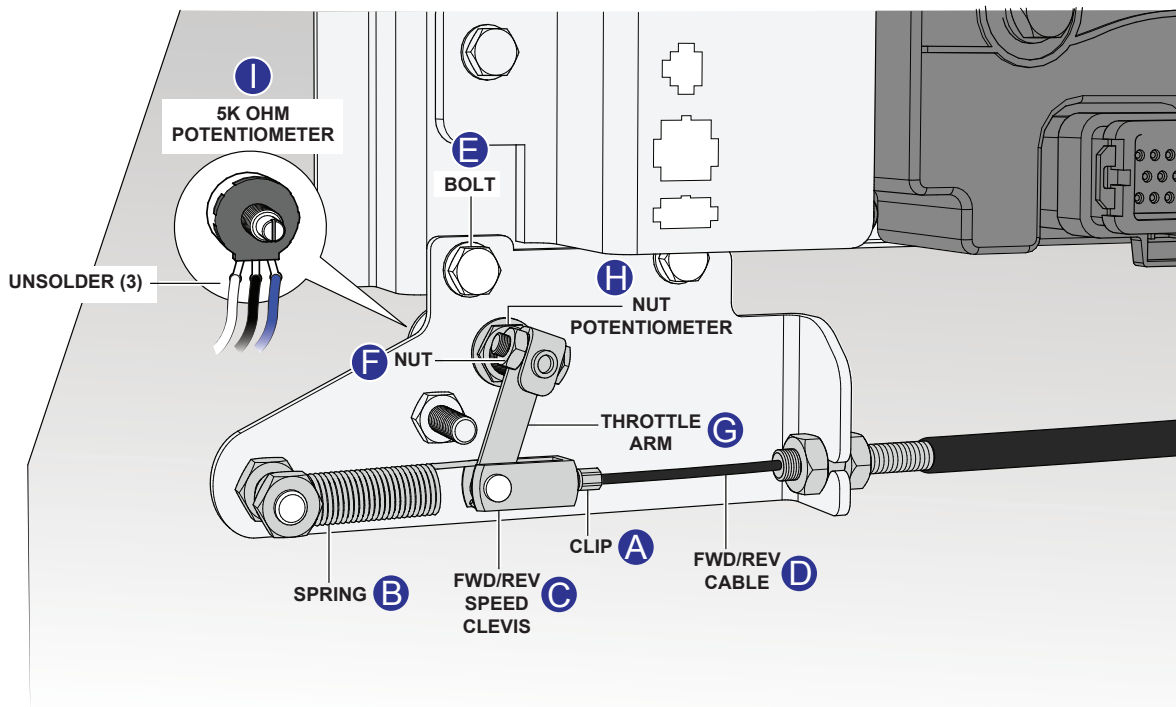

Figure 21. 5K Ohm Potentiometer Replacement

5K OHM POTENTIOMETER REPLACEMENT

The speed on the the electric Mini Dumper is controlled by a 5Kohm potentiometer. This potentiometer provides a 0~5 VDCinput signal to the motor controller via pin-13. Reference wiring diagram.

Use the following procedure when installing a replacement potentiometer. Reference Figure 21.

1. Lift the Mini Dumper and place wooden blocks at the front and rear of the Mini Dumper. Place blocks so that the front and rear wheels can rotate freely just above the ground
2. Remove the four screws that secure the control panel to the frame.
3. Carefully set control panel down.
4. Unhook the clip attached to the FWD/REV speed clevis (Figure 21Figure 21A). Position the clip downward.
5. Next, remove the spring (Figure 21B) from the FWD/REV speed clevis.
6. Remove the FWD/REV speed clevis (Figure 21C) from the throttle arm.
7. Position the FWD/REV cable (Figure 21D) away from throttle bracket.
8. Remove the two bolts (Figure 21E) that secure the throttle bracket to the frame.
9. Loosen the nut (Figure 21F) that secures the potentiometer to the throttle arm.
10. Slide the throttle arm (Figure 21G) off the output shaft of the potentiometer.
11. Remove the nut that secures the potentiometer to the throttle bracket (Figure 21H).
12. Next, unsolder the **WHITE, BLACK** and **BLUE** wires connected to the potentiometer (Figure 21I). Mark orientation.
13. Solder the **WHITE, BLACK** and **BLUE** wires removed in step 12 back onto the 5K ohm replacement potentiometer in the same orientation.
14. Install new 5K ohm potentiometer back onto throttle bracket and secure with retaining nut.
15. Reinstall throttle arm back onto output shaft of potentiometer. Do not tighten retaining nut at this time.
16. Reconnect the FWD/REV speed cable and associated hardware back onto throttle bracket.

THROTTLE ADJUSTMENT

1. Using a small flat blade screw driver, rotate the shaft on the potentiometer **fully** counterclockwise.
2. Fully engage the deadman control lever, then fully squeeze the forward speed control lever.
3. Verify that a 4mm gap (Figure 22) exist between the throttle arm and the stop screw. Adjust if necessary.
4. With the deadman lever held down and the forward speed lever still fully engaged, turn the potentiometer adjustment screw slowly clockwise until the motor **clicks**. Verify that the wheels rotate forward. slowly.
5. Tighten the nut (Figure 21H) that secures the output shaft of the potentiometer to the throttle arm.
6. Remove support blocks, and reinstall control panel.

NOTICE

Ensure when the forward speed lever is released the motor dis-engages the drive before the potentiometer arm makes contact with the stop screw.

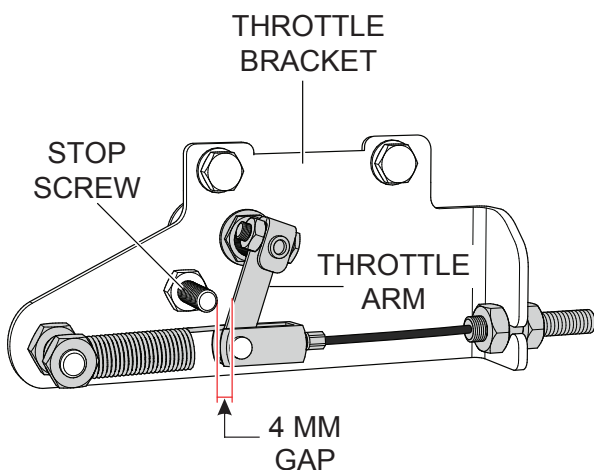

Figure 22. Throttle Arm Gap (4 MM)

FREE-WHEELING

NOTICE

Battery must be **sufficiently charged** in order for the brake bypass switch to operate.

In the event the Mini Dumper needs to be moved with the electric motors **OFF** or not working, please follow the procedure below:

1. Turn ignition key to the **ON** position (Figure 23).
2. **Push** upwards and **hold** the brake bypass momentary switch (Figure 23).

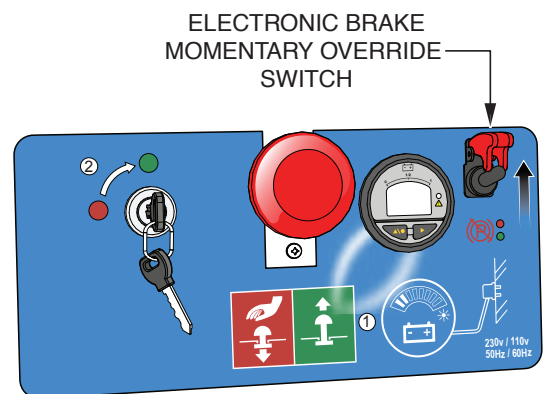

Figure 23. Brake Bypass Momentary Switch

3. The Mini Dumper can now be moved.

TIRES/WHEELS/LUG NUTS

Tires and wheels are very important and critical components of the Mini Dumper. When specifying or replacing the wheels, it is important that the wheels, tires, and axle are properly matched.

CAUTION

DO NOT attempt to repair or modify a wheel. If the rim is cracked, replace the rim immediately and inspect the tire for cuts, wear, and deformations.

TIRE WEAR

The tires (Figure 24) used on the Mini Dumper are pneumatic. Proper inflation is 28 PSI (193 kPa). In addition, inspect the tires for cuts, wear and deformity.

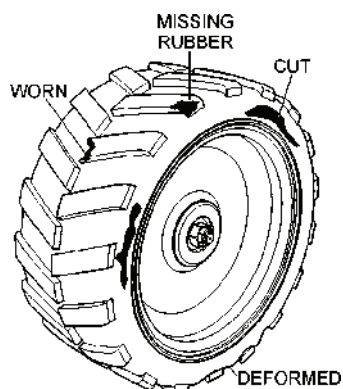

Figure 24. Tire Inspection

LUG NUT TORQUE REQUIREMENTS

It is extremely important to apply and maintain proper wheel mounting torque on the TuffTruk. Be sure to use only the fasteners matched to the cone angle of the wheel. Proper procedure for attachment of the wheels is as follows:

1. Start all wheel lug nuts by hand.
2. Torque all lug nuts (Figure 25) in sequence. **DO NOT** torque the wheel lug nuts all the way down. Tighten each lug nut in 3 separate passes as defined by Table 6.

Table 6. Tire Torque Requirements

Wheel Size	First Pass FT-LBS	Second Pass FT-LBS	Third Pass FT-LBS
480 x 8 in.	20-25	35-40	50-65

3. After first road use, retorque all lug nuts in sequence. Check all wheel lug nuts periodically.

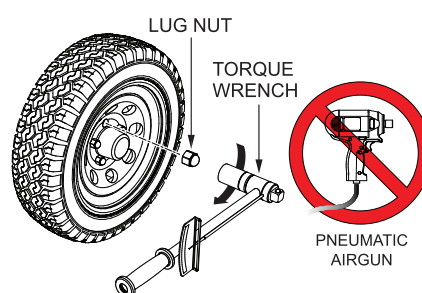
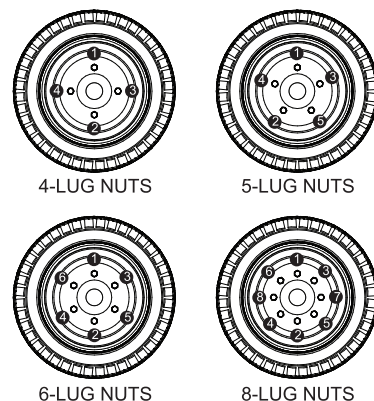

Figure 25. Lug Nut Torque Sequence

TUB REMOVAL/PLACEMENT

1. Place both locking levers in the **unlock** position (Figure 26).

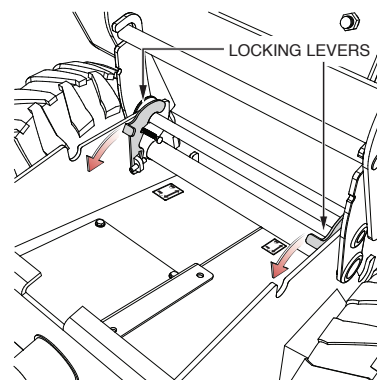

Figure 26. Locking Levers (Unlock)

2. With **two people**, lift and remove the tub (Figure 27). Place the tub onto its side away from the unit.

CAUTION

DO NOT attempt to lift or move the tub by yourself.

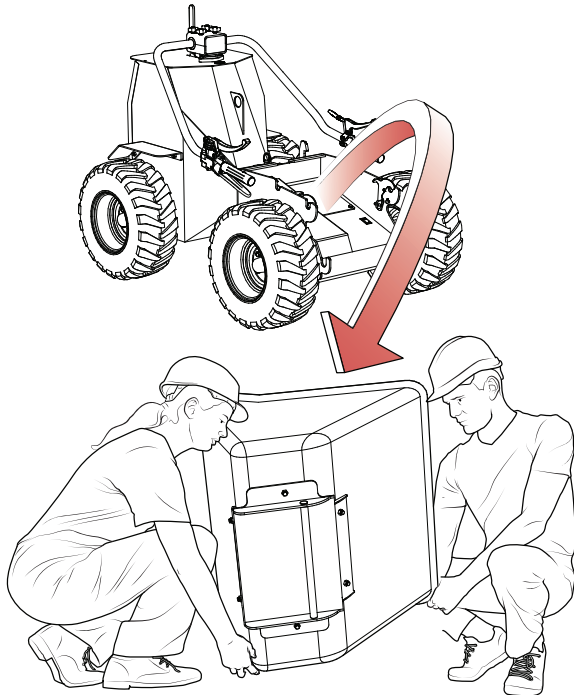

Figure 27. Tub Removal

3. Orient the tub tipping bracket to the base of the tub as shown in Figure 28.

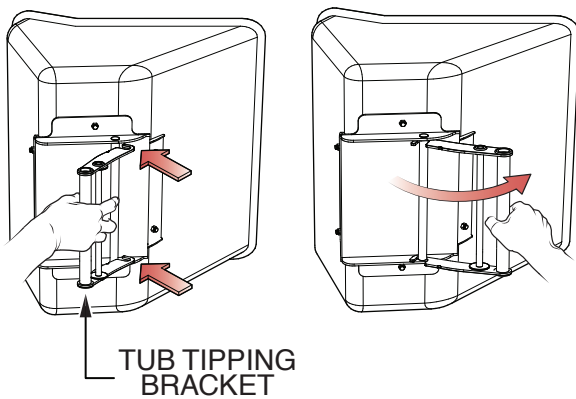

Figure 28. Tipping Bracket Orientation

4. With **two people**, lift the tub and tipping bracket onto the chassis (Figure 29). Make sure the tipping bracket pivot bar rests within the tipping slots.

CAUTION

DO NOT attempt to lift or move the tub by yourself.

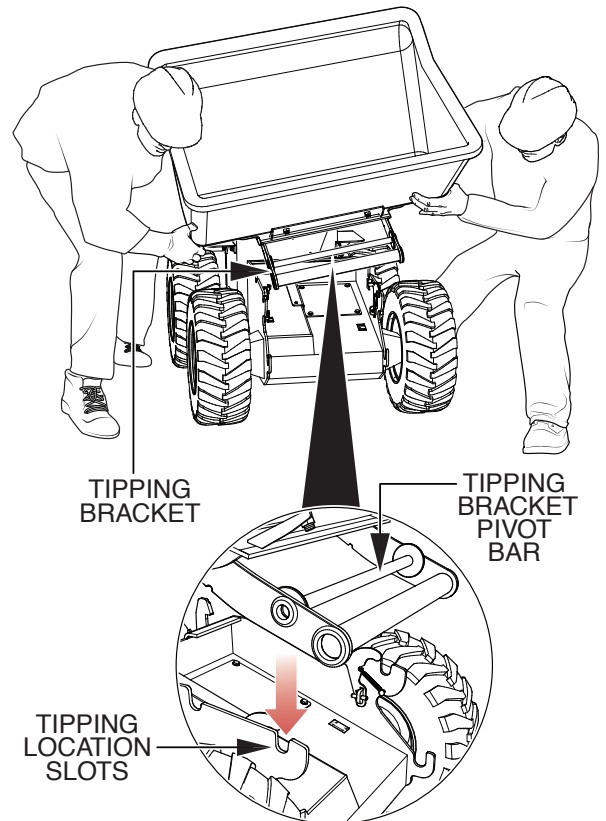

Figure 29. Tub Placement

5. Tilt the tub into its discharge position and place both locking levers in the **lock** position (Figure 30).

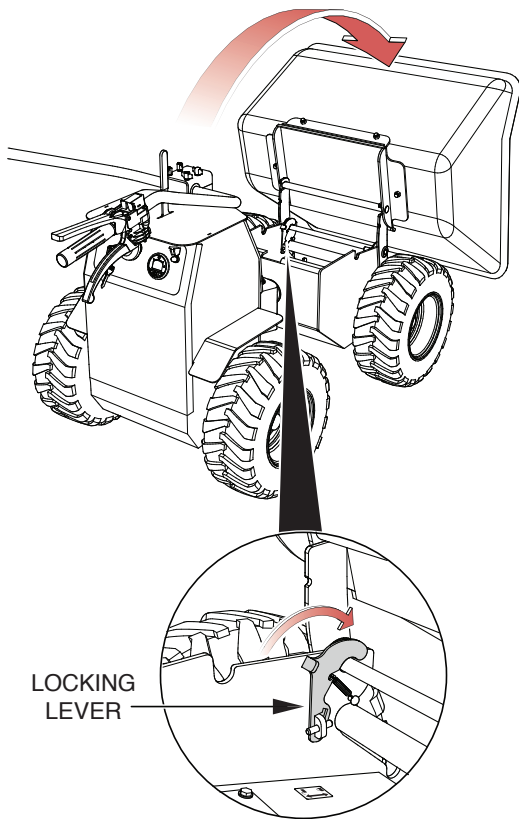

Figure 30. Locking Levers (Lock)

6. Place the tub in the forward position and make sure it is secured firmly under the tub catch (Figure 31). Adjust the tub catch if necessary.

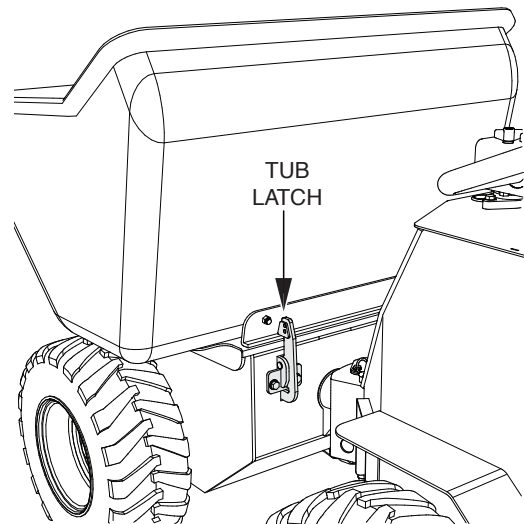

Figure 31. Tub Latch

TUFFTRUK MINI DUMPER STORAGE

For storage of the Mini Dumper for over 30 days, the following is recommended:

- Clean the entire Mini Dumper.
- Clean tub of all debris and foreign matter.
- Cover the Mini Dumper with a plastic sheet in a moisture and dust-free location out of direct sunlight.

AGM BATTERY CHARGING

To maximize the life of your AGM battery, it is important that it is properly charged. As with all lead-acid batteries, both over- and under-charging an AGM battery will result in **shortened service life**. The AGM batteries are sealed for life units and do not require any fluid top up.

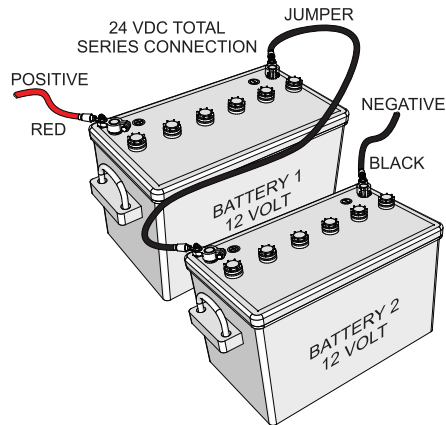

Figure 32. Battery Series Connections

The EB500 Mini Dumper is equipped with an on-board SMART charger (Figure 33) which maintains the battery full charge condition without resulting in over charging.

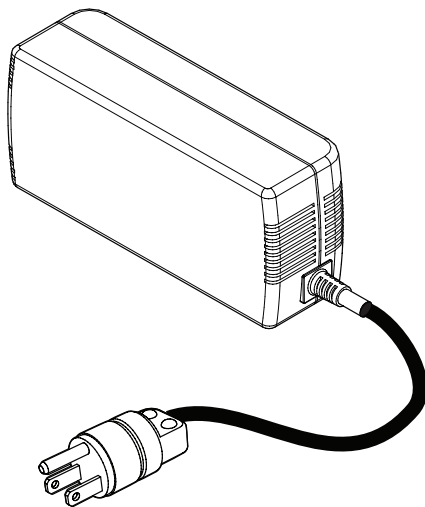

Figure 33. Battery Charger

Charging System Inspection

- The charger's AC power cord should be free of breaks or cuts and the wall plug socket should be clean and free from debris.
- The cable connectors from the on-board charger should be clean and properly mate with the battery terminals to ensure a sound connection.

Battery Inspection

- Check battery cables are not damaged.
- Connectors should be free of corrosion.
- Make sure battery cable post or eyelet connectors are tight to avoid arcing.

Charging Guidelines

- When the batteries have been discharged to $\frac{1}{4}$ full as indicated on the battery gauge it is time to have the batteries fully charged. Plug the on-board battery charger power cord into a 240 VAC power outlet.

Allow batteries to complete a full charge and **do not disconnect until fully charged**. Once fully charged, the on-board **SMART** battery charger will indicate a **GREEN** status light indicating that the batteries are fully charged.

NOTICE

The charging light is normally **ORANGE** which changes to **GREEN** when the batteries are fully charged.

- **DO NOT** charge batteries i.e. if the batteries have only discharged to $\frac{3}{4}$ full as indicated on the battery gauge. There is no need to connect the battery charger power cable to the AC power outlet.
- It is recommended to use the Mini Dumper until the batteries have discharged to $\frac{1}{4}$ full as indicated on the battery gauge, then place the batteries into a full charge cycle.
- **ALWAYS** charge batteries in a well ventilated area as gasses (fumes) may be released through the pressure relief valve if the batteries are excessively over-charged.
- **NEVER** charge a frozen battery.
- Ideal charging temperatures: 32°F to 104°F (0°C to 40°C)

DIAGNOSTICS

NOTICE

The Curtis 1229 controller is not repairable in the field. Please contact your nearest Flextool Authorized Service Center (ASC) for repair or replacement.

The Curtis1229 controller detects a wide variety of faults or error conditions. Diagnostic information will be shown on the Curtis 3100R diagnostic display (Figure 34). Error or faults will be displayed in the format “Er ##”.

The error code shown in Figure 34 is an **encoder** failure (Er 18). Reference the error code table shown below for additional codes.

Some errors may be corrected by simply turning the ignition key off, then back on and see if the fault clears. If that does not work turn the ignition to the off position and remove the 35-pin connector from the controller.

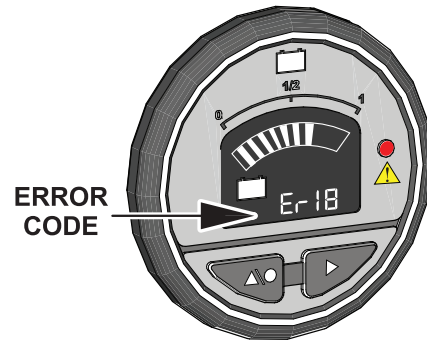

Figure 34. Curtis 3100 Diagnostic Gauge

Check the connector for corrosion or damage, clean if necessary and reinsert. If that does not correct the problem, please contact your nearest Flextool Authorized Service Center (ASC) for repair or replacement.

Error Codes			
1	HW Failsafe	29	Supervisor SW 4 Fault
2	PLD Clock Fail	30	Supervisor SW 5 Fault
9	Calibration Reset	31	Supervisor KSI Voltage Fault
10	Main Brake Driver Overcurrent	32	Supervisor Motor Speed Fault
11	Main Driver Open Drain	33	Supervisor Dir Check Fault
12	EMR Redundancy	34	External Supply Fault
13	EEPROM Failure	36	EM Brake Driver Open Drain
15	Main Contactor Dropped	37	EM Brake Driver On
16	Current Sensor	41	Pot 1
17	Main Contactor Welded	42	Pot 2
18	Encoder	43	Pot 3
19	PDO Timeout	50	Severe Undervoltage
20	Supervisor Comms	52	Controller Severe Undertemp
21	Supervisor Watchdog	53	Controller Severe Overtemp
22	Supervisor Pot 1 Fault	54	Precharge Failed
23	Supervisor Pot 2 Fault	70	Driver Shorted
24	Supervisor Pot 3 Fault	71	Driver 3 Fault
25	Supervisor Pot H Fault	72	Driver 3 Overcurrent
26	Supervisor SW1 Fault	73	Driver 4 Fault
27	Supervisor SW2 Fault	74	Driver 4 Overcurrent
28	Supervisor SW3 Fault	75	Driver 5 Fault
		76	Driver 5 Overcurrent
		77	Driver 6 Fault
		78	Driver 6 Overcurrent
		79	Correlation Fault
		80	HPD Sequencing
		81	Parameter Change
		82	NV Memory Fault
		90	Motor Temp Hot Cutback
		92	Motor Open
		93	Controller Overcurrent
		94	VBAT Too High
		95	Controller Undertemp Cutback
		96	Stall Detected
		97	Controller Overtemp Cutback
		98	Overvoltage Cutback
		99	Undervoltage Cutback
		101	User Fault Estop
		102	User Fault Severe

Troubleshooting (Error Codes)

The machine controller detects a wide variety of faults or errors. Diagnostic information can be obtained on the 3100R fuel gauge display where an error code in the format "Err ##". The troubleshooting chart below describes the error code faults and their possible causes. Whenever a fault is encountered the first action should be to turn off the ignition and push in the E-stop button. Then pull out the E-stop button and turn the ignition back on to see if the fault clears. This is the RESET procedure: If the error code does not clear after the machine RESET, turn off the ignition switch and remove the 35-pin connector. Check the connector for correction or damage, clean it if necessary, and reinsert it. If the error is still seen then the wiring and connections on the machine should be checked for breakages or loose connections. The table below should be used as a reference once the above checks have been carried out.

Error Code	Symptom	Possible Problem	Solution
1	HW fail-safe Motor fault voltage (hardware failure)	Motor voltage does not correspond to throttle request?	Check for short in motor or motor wiring.
10	Main brake driver over current.	Short circuit or overloaded controller driver?	Check brake controller driver. Reference Curtis controller owner's manual.
15	Main current dropped.	Main contactor failed to open?	Clean the contactor switch.
17	Main contactor welded.	Main contactor fault / failed to close?	Replace contactor.
33	Supervisor DIR check fault.	Program issue?	If fault is on an external signal, check that signal first. If no problem with the external signal, likely indicates an internal controller fault. Reference Curtis controller owner's manual
34	External supply fault.	Under voltage?	Check control wiring circuit, potentiometer wiring in particular.
36	EM-brake driver open drain.	Hold voltage set at 90%?	Check brake electrical connectors. Check continuity. Replace motor brake if failed.
54	Pre-charge failed/fault.	Low battery voltage?	Check battery voltage. 25V (11/12V per battery) is good condition, 22V (9/10V per battery) or lower is bad battery condition.
		Short circuit on traction motor outputs?	
80	HPD sequencing HPD fault present > 10 seconds.	Misadjusted throttle?	Adjust. See maintenance section.
		Broken throttle potentiometer or throttle mechanism?	Replace.
92	Traction motor open / not connected. Controller cannot see the motor.	Short circuit in the motor?	Check the resistance across the motor leads.
99	Undervoltage cutback.	Battery voltage < undervoltage threshold?	Check connection at battery or controller. Check no corrosion on the battery terminals.

Quick checks if no reading on the fuel gauge and the machine does not operate:

1. Check 10-amp ignition fuse located on the backside of the control panel. Reference 'Electronic Component Locator' drawing.
2. Check 100-amp main fuse*located on the backside of the control panel. Reference 'Electronic Component Locator' drawing.
2. When changing the 100-amp fuse, ensure that the positive battery cable is fully disconnected. Electrical maintenance should be carried out by a qualified person.

TROUBLESHOOTING

Troubleshooting		
Symptom	Possible Problem	Solution
Loss of Power.	Defective motor controller?	Check or replace motor controller.
	100A main fuse blown?	Check or replace fuse.
	10A ignition fuse blown?	Check or replace fuse.
	Emergency Stop Switch open?	CLOSE switch. Pull to close.
	Low electric motor RPM?	Check electric motor voltage.
	Defective batteries?	Check or replace batteries.
	Defective contactor?	Check or replace contactor.
Loss of Travel Speed.	FWD/REV speed cable signal not present?	Check or replace 5K ohm potentiometer.
	REV speed switch signal not present?	Check or replace switch inside reverse lever.
System jerky when started.	Defective motor controller?	Check or replace motor controller/software.
	FWD/REV speed signal intermittent?	Check or replace 5K ohm potentiometer.
Difficult to steer.	Low tire pressure?	Check tire pressure.
	Defective damper or steering rod?	Check or replace damper or steering rod.
Parking brake will not hold.	Defective electric motor?	Check or replace electric motor.
	Defective motor controller?	Check or replace motor controller/software.
Difficulty in stopping.	Defective deadman microswitch?	Check or replace microswitch.
	Defective brake motor?	Check or replace electric motor.
	Defective motor controller?	Check or replace motor controller/software.
Electric motor will not start.	Defective motor controller?	Check or replace motor controller.
	100A main fuse blown?	Check or replace fuse.
	10A ignition fuse blown?	Check or replace fuse.
	Emergency Stop Switch open?	Close switch. Pull to close.
	Defective batteries?	Check or replace batteries.
	Defective contactor?	Check or replace contactor.
	Defective ignition switch?	Check or replace ignition switch.

ELECTRONIC COMPONENT LOCATOR

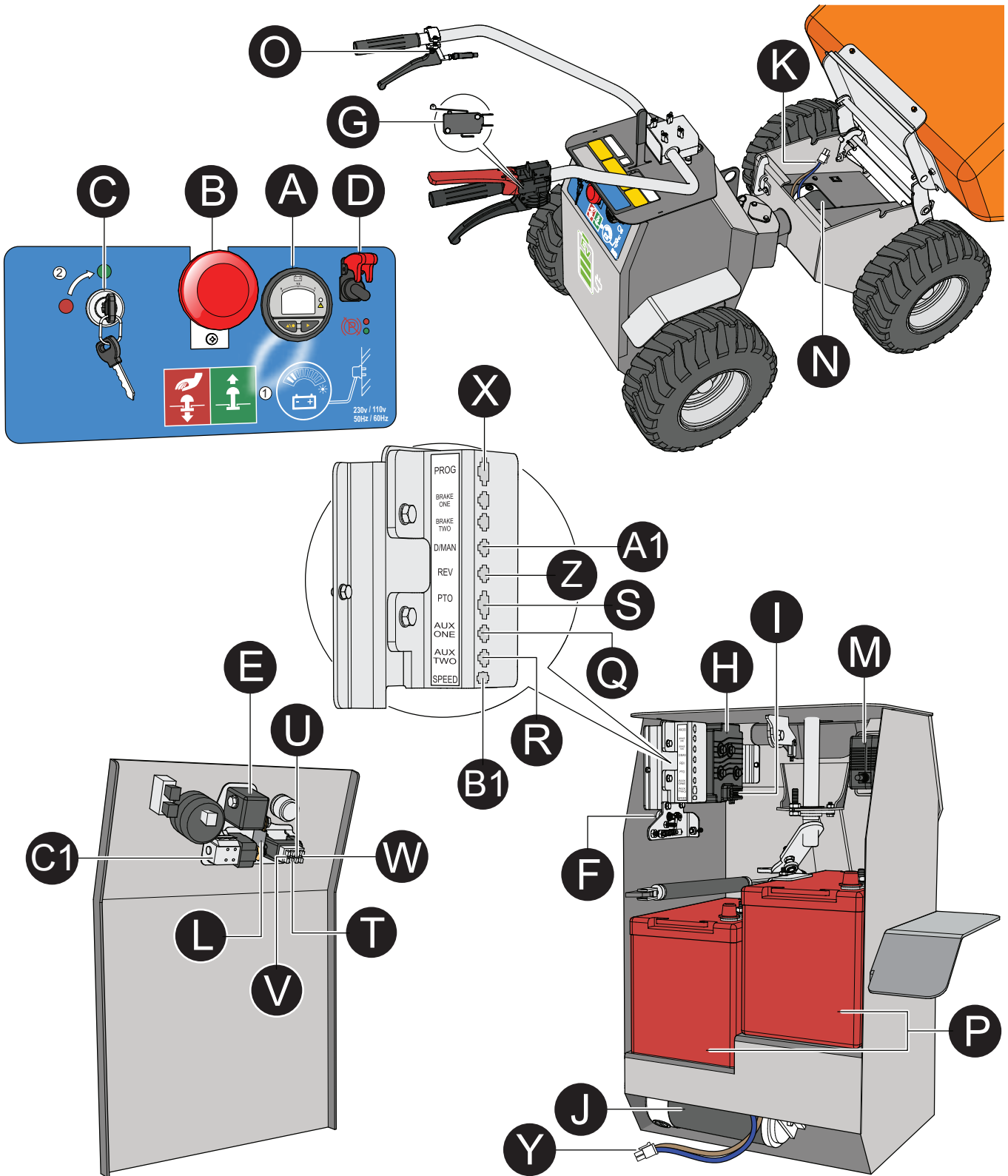

This page is intentionally blank.



Parchem Construction Supplies Pty Ltd

1956 Dandenong Road, Clayton VIC 3168, Australia

Phone: 1300 353 986

flextool.com.au

ABN 80 069 961 968

This manual summarises our best knowledge of the product based on the information available at the time of publication. You should read this manual carefully and consider the information in the context of how the product will be used. Our responsibility for products sold is subject to our standard terms and conditions of sale.

DISCLAIMER:

Any advice, recommendation, information, assistance or service provided by us in this manual is given in good faith and is believed by us to be appropriate and reliable. However, any advice, recommendation, information, assistance or service provided by us is provided without liability or responsibility PROVIDED THAT the foregoing shall not exclude, limit, restrict or modify the right entitlements and remedies conferred upon any person or the liabilities imposed upon us by any condition or warranty implied by Commonwealth, State or Territory Act or ordinance void or prohibiting such exclusion limitation or modification. The product can be expected to perform as indicated in this manual so long as operation and operational procedures of the individual products are followed as recommended in this manual.

Design and technical specifications may be subject to changes.

© This publication is copyright. All rights are reserved. Flextool is a registered trade mark and TuffTruk is a trade mark of Parchem Construction Supplies Pty Ltd.

FOR MORE INFORMATION

CONTACT US ON 1300 353 986 OR VISIT flextool.com.au