

INSTRUCTION MANUAL

RIDE ON POWER TROWEL

FP1046-2





Use this guide along with the parts lists attached to locate and identify components of your trowel. When ordering replacement parts, be sure to provide the model number and serial number from the trowel.



Foreword

Quality assurance / machine break in

The PARCHEM Ride-on Trowel is the product of extensive engineering development designed to give long life and unmatched performance. Once machines are fully assembled, a run-in test is performed to ensure quality standards of the highest level. A series of operational tests are conducted on concrete, incorporating a phase of operations at 1/2 to 3/4 throttles and a final run phase at full throttle for a minimum of 20 minutes.

You can help ensure that your Ride-on will perform at top levels by observing a simple routing on first use. Consider that your new Ride-on Trowel is like a new car. Just as you would break in a new car to the road or any new machine to the job, you should start gradually and build up to full use. Learn what your machine can do and how it will respond. Refer to the engine manufacturer's manual for run-in times. Full throttle and control may be used after this time period, as allowed by material. This will serve to further break in the machine on your specific application, as well as provide you with additional practice using the machine.

We thank you for the confidence you have placed in us by purchasing a PARCHEM Trowel Ride-on Trowel and wish you many years of satisfied use.

Table of contents

Foreword	3
Safety precautions	5
Assembly instructions	6
1 Battery – Shipped dry – No acid	6
2 Steering handle assembly	6
3 Pitch control Assembly	6
4 Seat Assembly	7
5 Transporter Assembly	7
Operating Instructions	8
1 Starting procedures – warm temperatures	8
2 Starting procedures – cold temperatures	8
3 To Stop engine	8
4 Steering	9
5 Float/Trowel pitch setting	10
6 Blade synchronization (specially modified units only)	10
7 Transporter Use	11
Trowel arm adjustment fixture	12
1 Adjustment Procedure	13
2 Trowel arm adjustment screw	14
Maintenance	15
1 Preventative maintenance and routine service plan	15
2 Lubrication	16
3 Maintenance plan	17
4 Service	19
Labels	20
Specifications	21
1 Technical data sheet	21
2 Parts	22

Safety Precautions

- Always keep unauthorized, inexperienced, untrained people away from this machine.
- Rotating and moving parts will cause injury if contacted. Make sure guards are in place. Keep hands and feet away from moving parts.
- Fuel the machine only when the engine is stopped, using all necessary safety precautions.
- The engine must always be stopped before attempting any repair or adjustments. Ignition key should be off.



Danger: Never operate the machine in an explosive atmosphere, near combustible materials or where ventilation does not clear exhaust fumes. Repair fuel leaks immediately.
Refer to your engine owner's manual for more safety instructions.

- Be careful not to come in contact with the muffler when the engine is hot, serious burns may result!
- Always operate the machine in a seated position to maintain machine balance.
- The transporter is designed for moving the unit around the job site only. It is not to be used for towing the Ride-On unit off-site.
- When starting the trowel, do not exceed the $\frac{1}{4}$ throttle position as recommended. A higher setting could cause the centrifugal clutch to engage, turning the trowel blades.
- Be careful with the trowel around stub pipes or other obstructions on the floor. Should the machine catch, or hit such an obstruction, serious damage may result to the machine, or operator may be thrown from the machine.
- Excess surface water may result in sudden loss of control of steering.
- Disconnect battery before attempting any electrical maintenance.
- Ensure that the electrical dead-man switch, located on the right hand steering lever is operating. Placing your right hand on the steering lever will engage the safety switch. Removing your hand from the Lever will disengage the safety switch and stop the engine. The engine will not start unless the safety switch is depressed. This safety feature must be used as designed

Assembly Instructions

1 **Battery – Shipped dry – No acid**

Connect and secure the battery cables before attempting starting procedures.

2 **Steering handle assembly**

The steering handles are shipped ready to connect. Position the handles over the handle sleeves so that the set-screws (2 per handle) are lined up with the tapped holes on the sleeves. Tighten the set-screws and test the mobility of the handles.

3 **Pitch control Assembly**

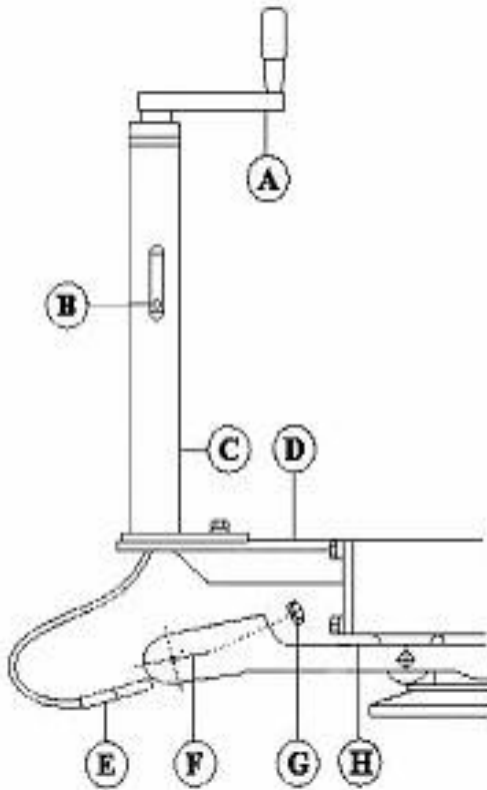

Bolt pitch control tube (C) to pitch control bracket (D) with bolts provided. Put cable end (E) through yoke arm (F) and secure with nylon insert locknut (G). For proper cable adjustment, turn crank (A) counter-clockwise to the stop position. Tighten nut (G) until all slack in the cable is removed. If more than 2 or 3 threads show through the nut, it should be turned back and the guide screw (B) moved to the next lower hole. Tension in the cable should then be readjusted. After adjusting tension, turn hand crank full clockwise (ABOUT 24 TURNS) and check for clearance between the yoke arm (F) and the gear box at point (H). There should be enough space to pass a business card through but not more than 1/8 inch.

4 **Seat Assembly**

Remove protective wrapping from seat. The seat is now ready to secure to the frame using included washers and hex nuts. If the seat adjuster is ordered, the slider bars must be positioned between the seat and the frame using included screws to secure the seat to the sliders, and then securing the sliders to the frame as indicated above.

5 **Transporter Assembly**

The components of the transporter (handle, frame, wheels, and parts bag) are shipped separately, requiring some assembly. Extend the handle outside the frame. Slide the handle along the frame cross-bar to align the hole on the handle with the hole on the "U" frame. Insert the large hitch pin (part #12487) through the hole to secure the handle to the "U" frame. Position one of the wheels on the axle and secure in place by inserting pin (part #10315) into the hole on the end of the axle. Repeat procedure for the other wheel.



CAUTION: The transporter is designed to be used on the job site only. Do not use the transporter to tow the machine off-site.



Operating Instructions

1 **Starting procedures – warm temperatures**

- Prior to starting the trowel, check the engine and gearbox oil levels. Be sure the fuel tank is full.
Fuel is not shipped with the unit. Check engine and gearbox oil levels. WARRANTY IS VOID IF RUN WITHOUT OIL. Fill tank with safety approved fuel containers. DO NOT MIX OIL WITH FUEL.
- Maintain left foot pressure on the dead-man safety switch. Engine will disengage and stop if safety switch is released. Do not tape, tie-down, or otherwise attempt to bypass safety device..
- Turn ignition key all the way. Allow engine to warm up before proceeding with full trowel operation.

2 **Starting procedures – cold temperatures**

Follow same procedure as above but allow for a longer warm up period 3-5 min. (In cold weather oil is much heavier to move. Extra time is required to heat the oil.)

3 **To Stop engine**

- Bring throttle to low idle, wait a few seconds.
- Remove left foot from dead-man safety switch.
- Turn off ignition key.

4 **Steering**

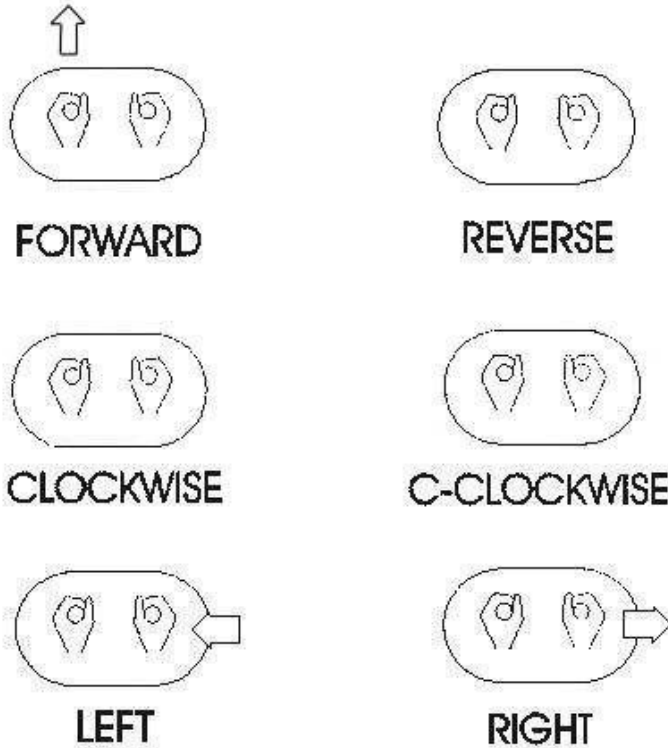

Guiding the machine on the slab is quite simple but does require some familiarity before actually working with the machine. The controls respond as shown in figure 2a below. Test the machine on a finished section of the floor, with the blades in a flat position, and the engine at a low revolution to gain the necessary feel for the steering.

For straight line movement, move both handles as one in the direction you wish to travel. Move the handles in opposite directions to produce rotation on the machines axis. Left handle forward, right handle backward for clockwise rotation. Left handle backward, right handle forward, for counter-clockwise rotation. Sideways direction is achieved by sideways movement of the right handle in the required direction of travel.



WARNING: SERIOUS INJURY OR PROPERTY DAMAGE MAY RESULT DUE TO TEMPORARY LOSS OF CONTROL IF OPERATED WITH EXCESS LIQUID ON THE CONCRETE SURFACE.

5 Float/Trowel pitch setting

Once you are familiar with the steering functions on a flat floor, you are ready to combine the steering with float/trowel pitch settings to produce the finish you require. The pitch adjustment feature of the PARCHEM RIDE-ON TROWEL permits quick and accurate pitch changes of the finishing/float blades, without having to stop the machine. Turning the adjustment crank-handle at the end of the pitch control tubes enables you to change the pitch whenever necessary to allow for varying conditions over the slab surface.

Each spider plate is adjusted independently. The pitch setting will affect the steering of your unit. Experiment with the settings as you test drive so you will know what to expect.



CAUTION: Do not let the machine stand in one spot on the soft concrete; This may place unnecessary strain on the clutch to break it free of the concrete. If the unit has been sitting for any length of time, break it free from the concrete before attempting operation.



CAUTION: When finishing concrete above grade, erect a situation barrier along the edge of the slab as a protective measure. The barrier must follow all applicable codes and should be such that it will stop the trowel from riding over the edge of the slab in case of loss of control.

6 Blade synchronization (specially modified units only)

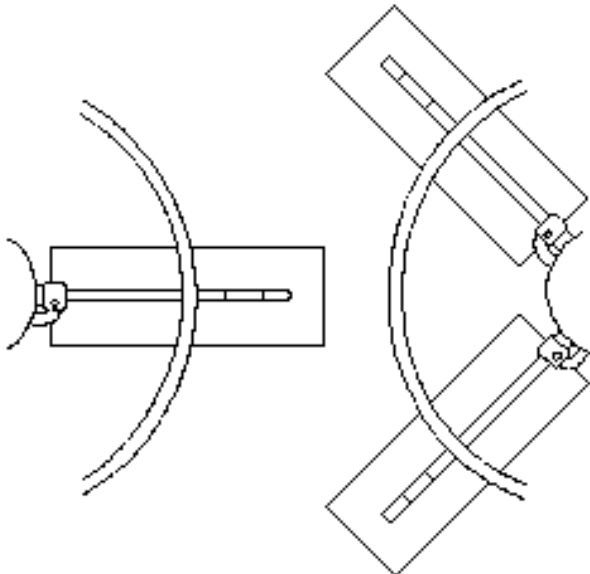

To avoid blades hitting, make sure spider plates are positioned as shown with respect to each other after performing any maintenance.

7 Transporter Use



The transporter is designed to be used on the job site only. Do not use it to tow the machine offsite.

The transporter has pick-up brackets located on the inside of the wheels which should be positioned under the pick-up points on the frame. Before connection, the handle will be pointing upwards at approximately a 45 degree angle. Pull the handle down, engaging the transporter and secure the bracket and transporter to the frame by locking the handle bracket in the frame lock by means of the hitch pin. Using the handle as a lever, the ride-on may now be moved. To disconnect the transporter, follow the above steps in reverse.

Trowel arm adjustment fixture

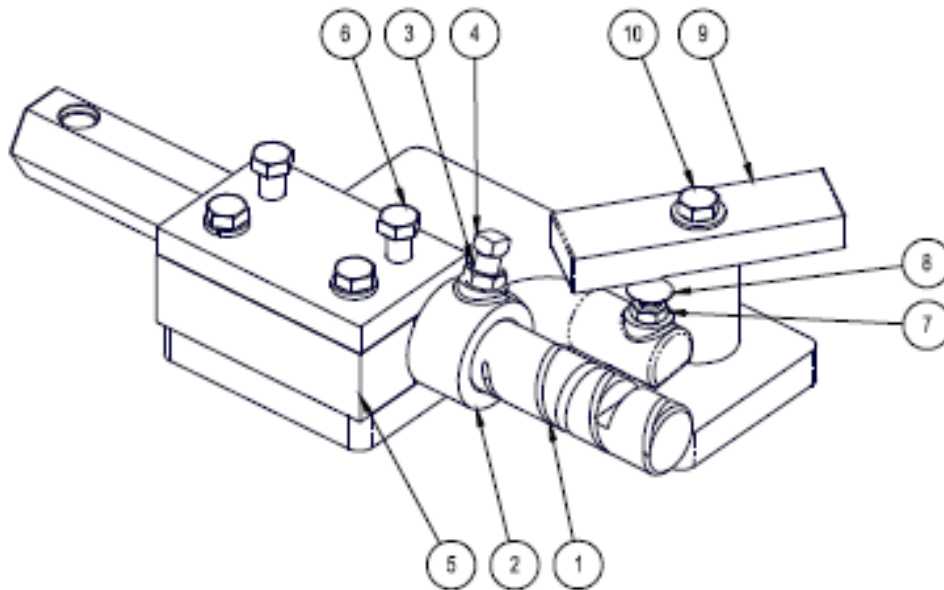

- | | |
|-----------------------|---------------------------|
| 1) 10411 – Trowel arm | 6) 10507 – Bolt |
| 2) 10817 – Lift lever | 7) 10816 – Jam nut |
| 3) 10808 – Jam nut | 8) 10815 – Carriage bolt |
| 4) 10809 – Set screw | 9) 10832 – Adjustment bar |
| 5) 10824 – Block top | 10) 10507 – Bolt |

The trowel arm adjustment fixture (20801) is reversible. By rotating the arm clamping fixture and the ring bolt, both left hand and right hand trowel arms may be adjusted. Before attempting adjustment, determine whether the trowel arm is right handed or left handed. When adjusting left hand trowel arms use the side of the fixture marked “L”. When adjusting right hand trowels arms use the opposite side. The adjustment bar will be set on “36” for the BT900 trowel arm.

1 Adjustment Procedure

- Remove all trowel arm assemblies (1 & 2 arm and attached lift lever) from suspected maladjusted spider plate.
- Remove lift lever (2) from trowel arm (1) by first loosening jam nut (3) then square head screw (4). If upon inspection (method left to discretion of serviceman) any trowel arm (1) is found to be in a bent condition, it must either be brought back to its original straight condition (method left to the serviceman's discretion) or replaced with new part.
- Replace lift levers (2) on new or straightened arms (1) by reversing procedure described above.



NOTE: IT IS IMPORTANT THAT WHEN TIGHTENING SQUARE HEAD SETSCREW (4), IT SEATS ITSELF SECURELY INTO DIMPLE MACHINED IN ARM.

- Place trowel arm assembly (1 and 2) in fixture (5) with lift lever (2) butting up against fixture. Secure in place with bolts (6).
- Loosen locknut (7) and screw carriage bold (8) down to full depth allowable. This will provide for ample clearance to swing adjustment bar (9) over head of carriage bolt. Adjustment bar (9) is stamped for appropriate size of machine. Swing appropriate side directly over carriage bolt (8) and secure in place with bolt (10).
- Adjust carriage bolt (8) upwards until contact is made with adjustment bar (9); holding carriage bolt in position with one wrench, tighten locknut (7) to secure in position with second wrench.



NOTE: IT IS VITALLY IMPORTANT TO ENSURE THAT ONCE THE CARRIAGE BOLT IS ADJUSTED TO THE CORRECT HEIGHT, IT DOES NOT MOVE BEFORE, OR DURING THE TIGHTENING OF LOCKNUT.

- This same procedure is to be followed with ALL arms from spider plate assembly, and will ensure correct and exact adjustment.



2 Trowel arm adjustment screw

When assembling trowel blades to trowel arms, the adjustment screw should NEVER protrude below the under-side surface to a trowel arm except when using for emergency on-site adjustment to level trowel blades. If the adjustment screw is not flush with the underside of the trowel arm, then this will cause the power trowel to bounce and vibrate especially at high speed. This will also cause the trowel blades to leave an uneven finish on the concrete due to the blades not being level to one another. Make certain that the adjusting screw is held firmly in place while tightening the bolt which secures the blade to the trowel arm.

Maintenance

1 Preventative maintenance and routine service plan

This trowel has been assembled with care and will provide years of service. Preventative maintenance and routine service are essential to the long life of your trowel. Your dealer is interested in your new machine and has the desire to help you get the most value from it. After reading through this manual thoroughly, you will find that you can do some of the regular maintenance yourself. However, when in need of parts or major service, be sure to see PARCHEM.

□ GENERAL

- Keep engine oil clean. Change according to engine manufacturer's specifications.
- Maintain the oil levels in the engine and gearbox assemblies. Change as required.
- Use only clean fuel in the engine.
- Check for loose nuts and bolts on the trowel and tighten as necessary.
- Check "V" belts for wear, replace if worn.
- Grease all fittings daily. See diagram.
- Clean the unit after every use to prevent hardening of concrete residue. Hard concrete is very difficult to remove, greatly increases weight and reduces efficient subsequent operation of unit.
- Check clutch linings regularly for wear. Linings should be changed when 3/4 worn. Do not allow metal to metal contact as this will damage the clutch drum. (New lining is 8mm.)

□ AIR CLEANER

Maintaining a clean engine will extend engine life. Keep air filter clean at all times. Clean air filter using the recommended solvent. See engine manual for proper cleaning procedure. Let the filter dry before reinstalling.

□ SPARK PLUG

Check and clean spark plugs regularly. A fouled, dirty spark plug causes hard starting and poor engine performance. Set spark plug gap to recommended clearance. Refer to engine manual.

BELT CHANGE PROCEDURE

Remove belt cover from the machine to expose the drive components. To change the primary drive belt, remove clutch from engine drive shaft, by removing bolt from the clutch. This releases belt from both the clutch and driven unit.

BELT TENSIONING SPECIFICATIONS



NOTE: Belts may become slightly loose after the first few hours of operation. It is important to retension the belts with the tool provided and use the table given as reference.

2 Lubrication

ENGINE OIL

The long life and successful operation of any piece of machinery is dependent on frequent and thorough lubrication.

Before using the trowel, always check your engine for oil. Use proper engine oil as recommended in the engine manufacturer's manual. Fill crankcase to levels as recommended.

SPIDER PLATE

There are 8 (eight) grease fittings on the spider plates, 4 (four) on each must be greased daily.

SPIDER PLATES MUST BE GREASED EVERY TIME MACHINE IS USED.

GEARBOX

Check the oil level sight plugs on both gearboxes daily to ensure the oil is half way on the site glass. Top up with Agma 8 compounded gear oil only. Gearbox capacity on the BT900 is 27oz./767ml.

TO CHANGE GEARBOX OIL

Place a pan beneath the drain plug to catch the oil. Remove the drain plug and the filler plug from the gearbox. After the oil has drained completely, replace the drain plug and tighten. Fill the gearbox through the filler plug with 27oz./767ml. of Agma 8 compounded gear oil. Replace the filler plug and tighten.

GREASE FITTINGS

There are 6 bearings in total. Grease all bearings and U-joints to ensure adequate supply of lubricant. They are located above the gearboxes (2 per gearbox) and 2 located in the drive system. The U-joints are located in the drive system as well.

3 Maintenance plan

Routine Service Intervals - Continued -		Each use	After 1.5 months or 50 hrs	Each 3 months or 100 hrs	Each 6 months or 200 hrs	Each 9 months or 300 hrs	Each 12 months or 400 hrs
Drive Train:							
Bearings	Lubricate	o	o	o	o	o	o
Universal couplings	Lubricate			o	o	o	o
Belt tension / Condition	Check	o	o	o	o	o	o
Clutch / Pulley operation	Check	o	o	o	o	o	o
LH spider plate assembly	Check	o		o	o	o	o
	Lubricate	o	o	o	o	o	o
RH spider plate assembly	Check	o		o	o	o	o
	Lubricate	o	o	o	o	o	o
Gearboxes:							
LH Gearbox oil	Check Level	o	o	o	o	o	o
	Change				o		o
RH Gearbox oil	Check Level	o	o	o	o	o	o
	Change				o		o
Gearbox breathers	Check operation			o	o	o	o
Retardant Spray System:							
Water pump operation	Check	o	o	o	o	o	o
Spray nozzles	Clean	o					
Retardant Fluid	Check levels	o					

Routine Service Intervals		Each use	After 1.5 months or 50 hrs	Each 3 months or 100 hrs	Each 6 months or 200 hrs	Each 9 months or 300 hrs	Each 12 months or 400 hrs
General Inspection:							
Operation of lights	Check		o	o	o	o	o
Battery	Clean & Check			o	o	o	o
	Recharge			o	o	o	o
	Replace						2 yrs
Guards	Check	o	o	o	o	o	o
Warning stickers	Check		o	o	o	o	o
Test run:	Check operation		o	o	o	o	o
Controls:							
Dead-man switch operation	Check	o	o	o	o	o	o
Throttle pedal operation	Check	o	o	o	o	o	o
Steering linkages	Check	o	o	o	o	o	o
	Lubricate		o	o	o	o	o
	Replace						As req'd
Pitch control levers	Check	o	o	o	o	o	o
	Lubricate		o	o	o	o	o
Joystick controls (N/A)	Check	o					
Hydraulic system (N/A)	Check levels			o	o	o	o
	Check hoses			o	o	o	o
	Replace hoses						2 yrs
Engine:							
Fuel pipes & clamps	Check		o	o	o	o	o
	Replace						2 yrs
Engine oil	Check Level	o	o	o	o	o	o
	Change		o		o		o
Engine oil filter	Replace				o		o
Oil cooler	Clean			o	o	o	o
Cooling Fins	Clean		o	o	o	o	o
Air cleaner	Check - clean	o	o	o	o	o	o
	Replace						o
Air Intake Line	Check				o		
	Replace						2 yrs
Fan Belt	Check tightness				o		o
	Replace						500 hrs
Valve clearance	Check-adjust				o		o
Fuel filter	Check & Clean			o	o	o	o
	Replace				o		o
Fuel Tank	Clean						500 hrs
Fuel Injection Nozzles	Check pressure						500 hrs
Fuel Injection Timer	Check						500 hrs
Injection Pump	Check						500 hrs
Engine wiring	Check						o



4 Service

Due to the nature and environment of use, power trowels are exposed to severe operating conditions.

Some general maintenance guidelines will extend the useful life of your trowel.

- The initial service for your power trowel should be performed after 25 hours of use, at which time your mechanic (or authorized repair shop) should complete all of the recommended checks in the schedule above.
- Regular service according to the schedule above will prolong the life of the power trowel and prevent expensive repairs.
- Keeping your power trowel clean and free from concrete residue is the single most important regular maintenance operation, over and above the checks in the service schedule above, that can be performed.
Components such as oil seals, belts, drive line parts and bearings are prone to premature wear from exposure to concrete residue. Using a spray-on release agent on your power trowel before each use will make clean-up after use easy and extend the time between replacement of most of the wearing components of the machine.
- After each use your power trowel should be cleaned to remove any concrete residue from the undercarriage and surrounding components. Use of a power washer will make clean up quick and easy, especially if a release agent was applied prior to use.
- In the Service Schedule above, items that should be checked, replaced or adjusted are indicated by "o" in the appropriate column. Not all power trowel models include the same features and options and as such not all service operations may have to be performed. For ease of recording place a checkmark (✓) through the "o" when the item is complete. If an item is not required or not completed place an "x" through the "o" in the box.
- For all fuel-line powered trowels the governed speed of the engine is 2000 to 3600 rpm. See engine manufacturer's manual for exact specifications. Care should be used when making any adjustments to the power trowel not to change the governed speed. Increasing the governed speed of the engine may lead to premature failure and void the manufacturer's warranty.
- Failure to have your power trowel regularly serviced and properly maintained in accordance with the manufacturer's instructions will lead to premature failure and void the warranty.

Labels

SAFETY PRECAUTIONS	
	<p style="text-align: center;"> DANGER</p> <p>EXPLOSION HAZARD Never operate the machine in an explosive atmosphere, near combustible materials or where ventilation does not clear exhaust fumes.</p>
	<p style="text-align: center;">WARNING</p> <p>BURN HAZARD Never come into contact with the engine or muffler when engine is operating or shortly after it is turned off. Serious burns may occur.</p>
	<p style="text-align: center;"> CAUTION</p> <p>ROTATING HAZARD Never place hands or feet inside safety guard rings. Serious injury will result from contact with rotating blades.</p>
	<p style="text-align: center;"> CAUTION</p> <p>MOVING PARTS Before starting the machine ensure that all guards and safety devices are in place and functioning properly.</p>
	<p style="text-align: center;"> ATTENTION</p> <p>READ OWNERS MANUAL Read and understand operator's manual before using this machine. Failure to follow operating instructions could result in serious injury or death.</p>



Specifications

1 Technical data sheet

ENGINE	Vanguard 35HP
DIAMETER IN CM	2 X 120
WEIGHT IN KG.	480
WIDTH IN CM	118 CM
LENGTH IN CM	244 CM
RPM	MAX. 150

2 Parts

2.1 Upper Framework and Guard Ring

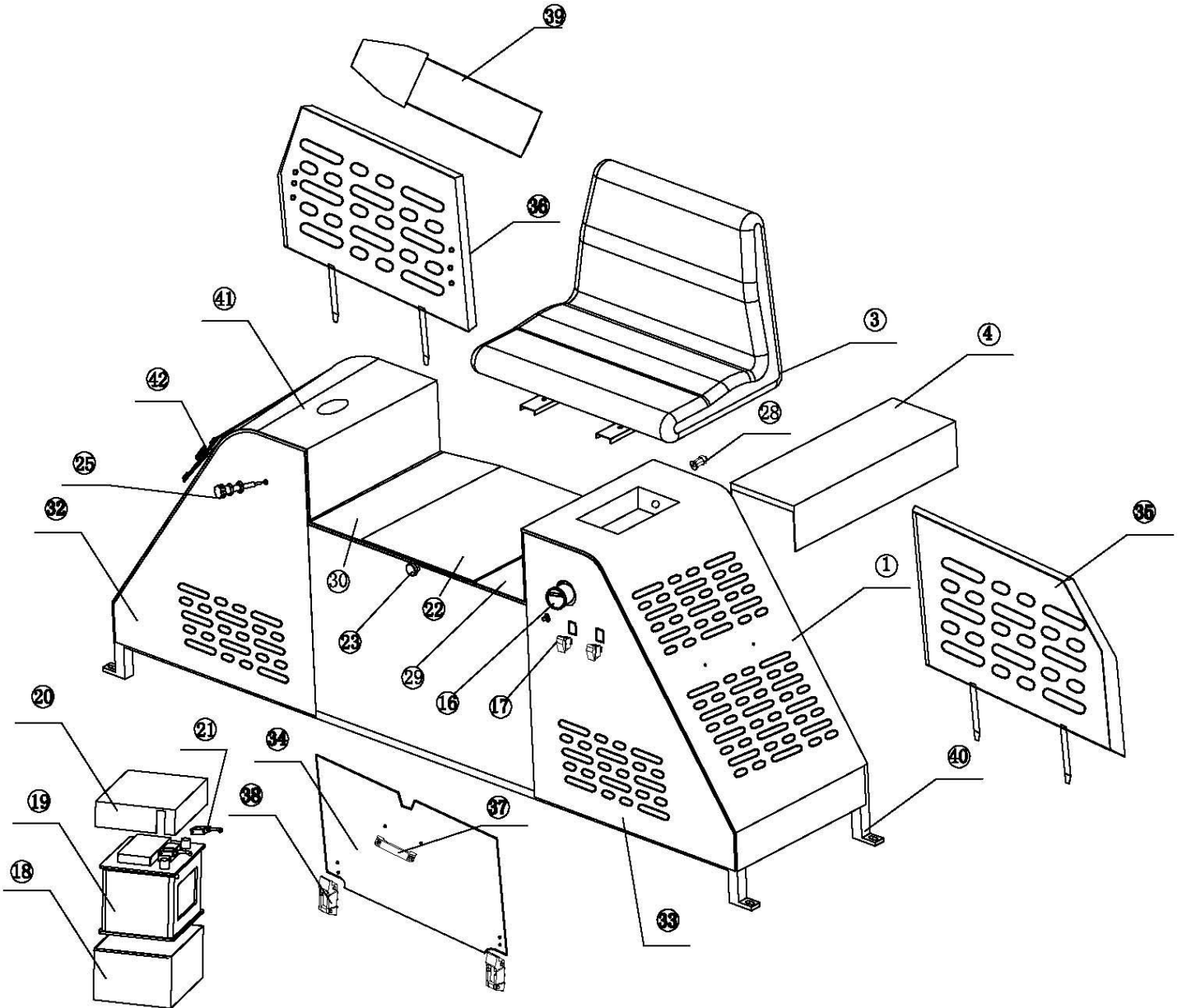



2.1 Upper Framework and Guard Ring cont.

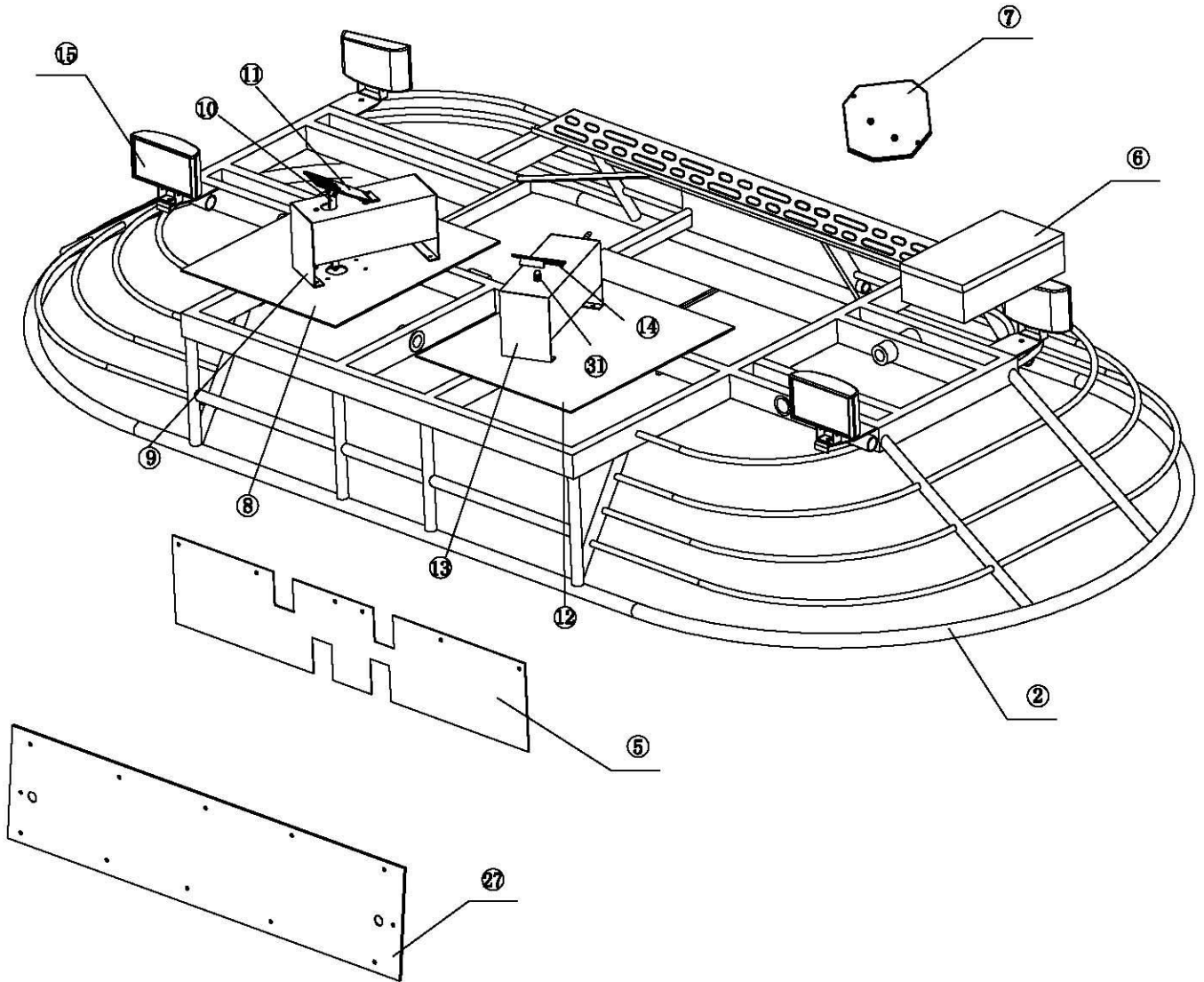

UPPER FRAMEWORK & GUARD RING PARTS LIST

Item No.	Part No.	Description	Qty.
1	JG846B080017L	SIDE PANEL LEFT	1
2	JG846A010200	GUARD RING	1
3	JG8360453	CHAIR	1
4	JG846A080200	THERMAL BAFFLE	1
5	JG846A080005	FENDER	1
6	JG846A080013	TOOL BOX	1
7	JG846A040100	FUEL/WATER TANK MOUNTING PLATE	2
8	JG846A080009	ANTISKID PLATE RIGHT	1
9	JG846A040200	PEDAL SUPPORT	1
10	JG846A040001	THROTTLE LEVER	1
11	JG846A040500	THROTTLE PEDAL	1
12	JG846A080008	ANTISKID PLATE LEFT	1
13	JG846A040300	PEDAL SUPPORT	1
14	JG846A040400	SHUT DOWN PEDAL	1
15	8360598	LIGHT	4
16	9904	HOUR METER	1
17	9641	LIGHT SWITCH	2
18	8360464	BATTERY BOX	1
19	8360019	BATTERY	1
20	8360463	BATTERY COVER	1
21	8360968	BATTERY CONNECTOR	2
22	JG846A080700	CHAIR PLATE	1
23	1046H8300	PIN SET	1
25	9555	CHOKE	1
27	JG846A080802	FRONT PANEL	1
28	9334	USD CHARGER	1
29	JG846A080801	COVER PLATE LEFT	1
30	JG846A080801	COVER PLATE RIGHT	1
31	9555	SHUT DOWN SWITCH	1



UPPER FRAMEWORK & GUARD RING PARTS LIST cont.

Item No.	Part No.	Description	Qty.
32	JG846B080016	FRONT PANEL RIGHT	1
33	JG846B080015	FRONT PANEL LEFT	1
34	JG846A080003	FRONT PANEL	1
35	JG846B080500	BACK COVER LEFT	1
36	JG846B080600	BACK COVER RIGHT	1
37	9678	HANDLE	1
38	9346	DRAW LOCK	2
39	9593	MANUAL HOLDER	1
40	JG846A080100	FRAME	1
41	JG846B080017R	SIDE PANEL RIGHT	1
42	Ft83608100	TROWEL HOLDER	1

2.2 Power System

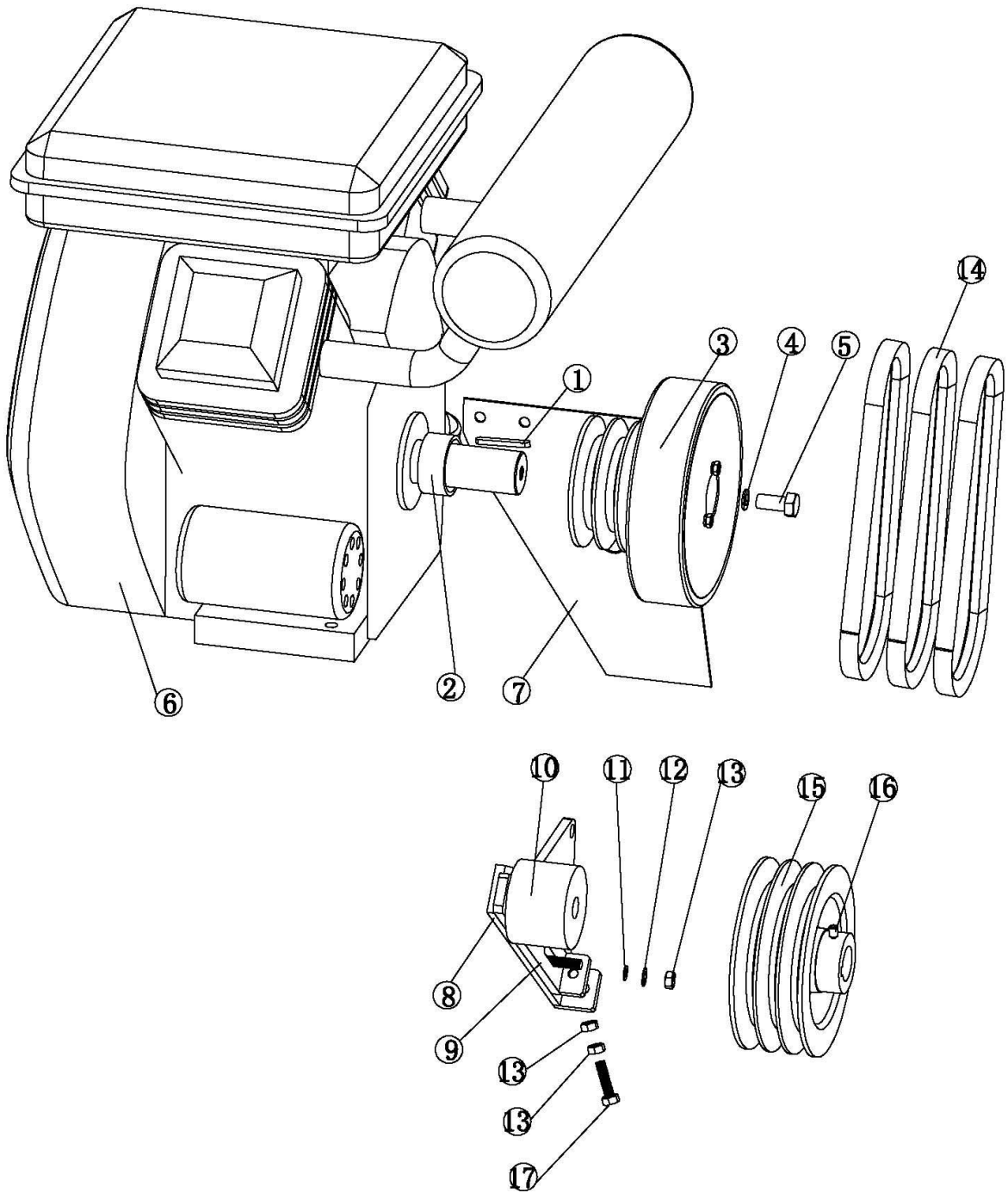



POWER SYSTEM PARTS LIST

Item No.	Part No.	Description	Qty.
1	9155	KEY	1
2	JG846A030005	SPACER	1
3	846A030400	CLUTCH	1
4	JG846A030006	SPACER	1
5	0529	BOLT	3
6	31000037	VANGUARD 35HP	1
7	JG846A080400	BELT GUARD	1
8	JG846A030100	TENSIONER MOUNTING	1
9	JG846A030200	TENSIONER BASE	1
10	JG846A030003	TENSIONER	1
11	9038	WASHER	1
12	9037	WASHER	1
13	9036	NUT	3
14	0249	BELT	3
15	JG846A030002	PULLEY	2
16	9216	SCREW	1
17	9605	BOLT	1

2.3 Operating System

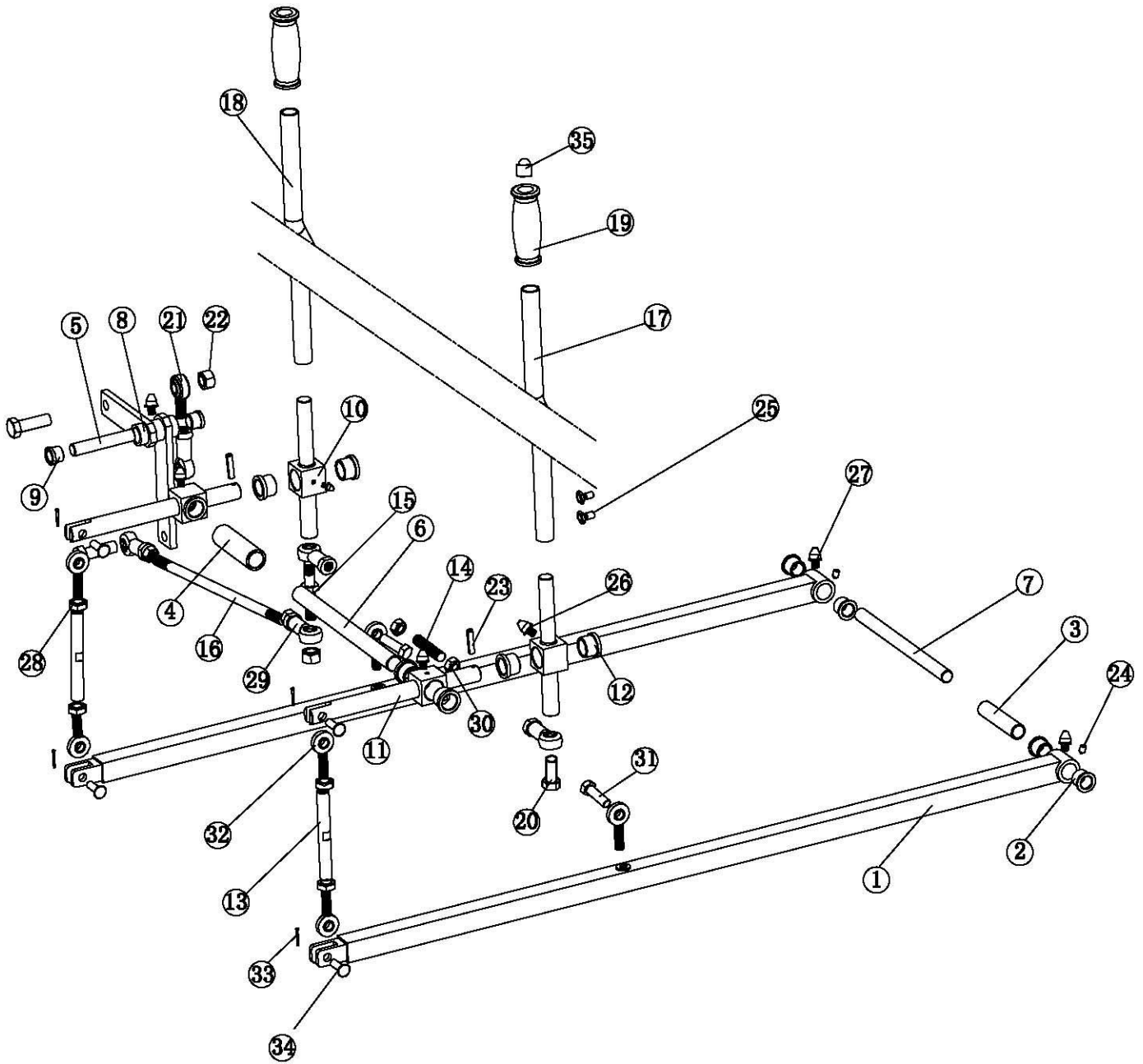

OPERATING SYSTEM PARTS LIST

Item No.	Part No.	Description	Qty.
1	JG846A020100	LEVER	2
2	JG846A020105	BUSHING	4
3	JG846A020001	BUSHING	1
4	JG846A020002	BUSHING	1
5	JG846A020003	TRANSMISSION SHAFT	1
6	JG846A020004	TRANSMISSION SHAFT	3
7	JG846A020005	TRANSMISSION SHAFT	1
8	JG846A020200	ROLLING PLATE	1
9	8361194	BUSHING	2
10	JG846A020006	SPINDLE HEAD	2
11	JG846A020007	SPINDLE HEAD	2
12	JG846A020008	BUSHING	8
13	JG846A020009	CONNTECTING ROD	2
14	JG846A020010	CONNTECTING ROD	1
15	JG846A020011	STUD	1
16	JG846A020012	CONNTECTING ROD	1
17	JG846A020300	OPERATING LEVER LEFT	1
18	JG846A020400	OPERATING LEVER RIGHT	1
19	9035	KNOB	2
20	9702	BOLT	4
21	9500	OSCILLATING BEARING	1
22	9513	NUT	4
23	9030	PIN	2
24	9101	SCREW	14
25	9112	NUT	4
26	9502	GREASE NIPPLE	2
27	9502	GREASE NIPPLE	5
28	9168	NUT	6
29	9501	OSCILLATING BEARING	5



OPERATING SYSTEM PARTS LIST cont.

Item No.	Part No.	Description	Qty.
30	9514	NUT	5
31	9703	BOLT	2
32	9464	OSCILLATING BEARING	6
33	9506	PIN	4
34	9505	PIN	4
35	8361031	WATER SPRAY BUTTON	1

2.3 Steering System

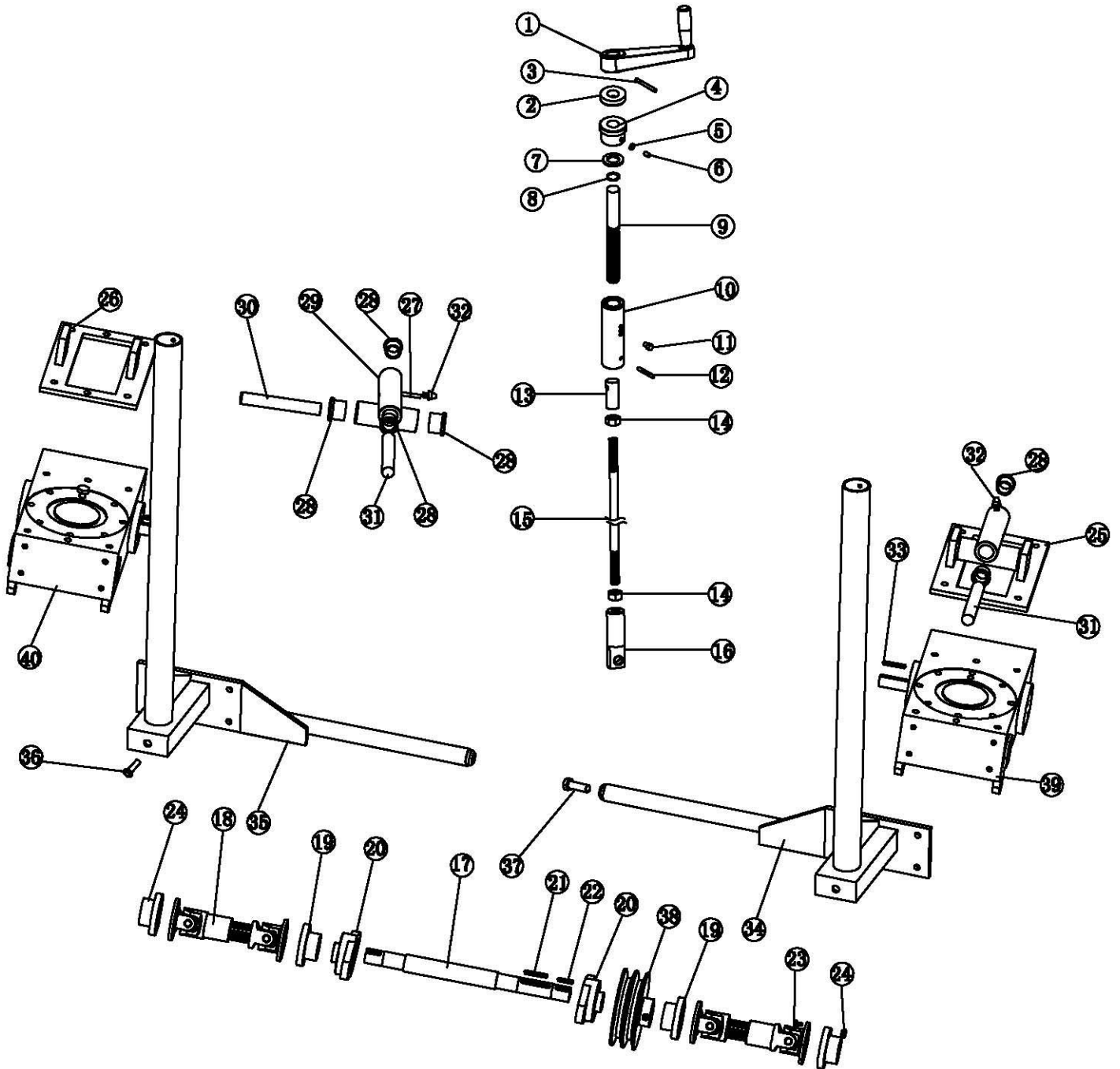

STEERING SYSTEM PARTS LIST

Item No.	Part No.	Description	Qty.
1	B8360470	PITCH HANDLE	2
2	9025	BALL BEARING	2
3	9157A	PIN	2
4	JG846A050004	BUSHING	4
5	9022	WASHER	2
6	9093	BOLT	2
7	4365504	SPACER	2
8	9027	WASHER	2
9	4365503	PITCH CONTROL SHAFT	2
10	JG846A050006	PITCH CONTROL SHAFT BUSHING	2
11	9028	SCREW	2
12	9157	PIN	2
13	JG846A050008	CONNECTOR	2
14	9059	NUT	4
15	JG846A050005	ROD	2
16	JG846A050007	CONNECTOR	2
17	JG846A030001	INTERMEDIATE SHAFT	1
18	JG846A030300	COUPLING	2
19	JG846A030004	FLANGE	4
20	9465	BEARING	2
21	9706	KEY	1
22	9707	KEY	2
23	9701	BOLT	16
24	9023	NUT	16
25	JG846A050100	HANGING BRACKET LEFT	1
26	JG846A050200	HANGING BRACKET RIGHT	1
27	JG846A050009	GREASE FITTING TUBE	1
28	JG846A050107	BUSHING	2
29	JG846A050300	CROSS SHAFT	1



STEERING SYSTEM PARTS LIST cont.

Item No.	Part No.	Description	Qty.
30	JG846A050001	ROLLING SHAFT	1
31	JG846A020004	ROLLING SHAFT	3
32	9502	GREASE FITTING	2
33	9709	KEY	2
34	JG846A050400	PITCH CONTROL BRACKET LEFT	1
35	JG846A050500	PITCH CONTROL BRACKET RIGHT	1
36	9702	BOLT	4
37	9703	BOLT	4
38	JG846A030002	PULLEY	1
39	JG846A060000L	GEARBOX LEFT	1
40	JG846A060000R	GEARBOX RIGHT	1

.3 Gearbox Assembly (Left)

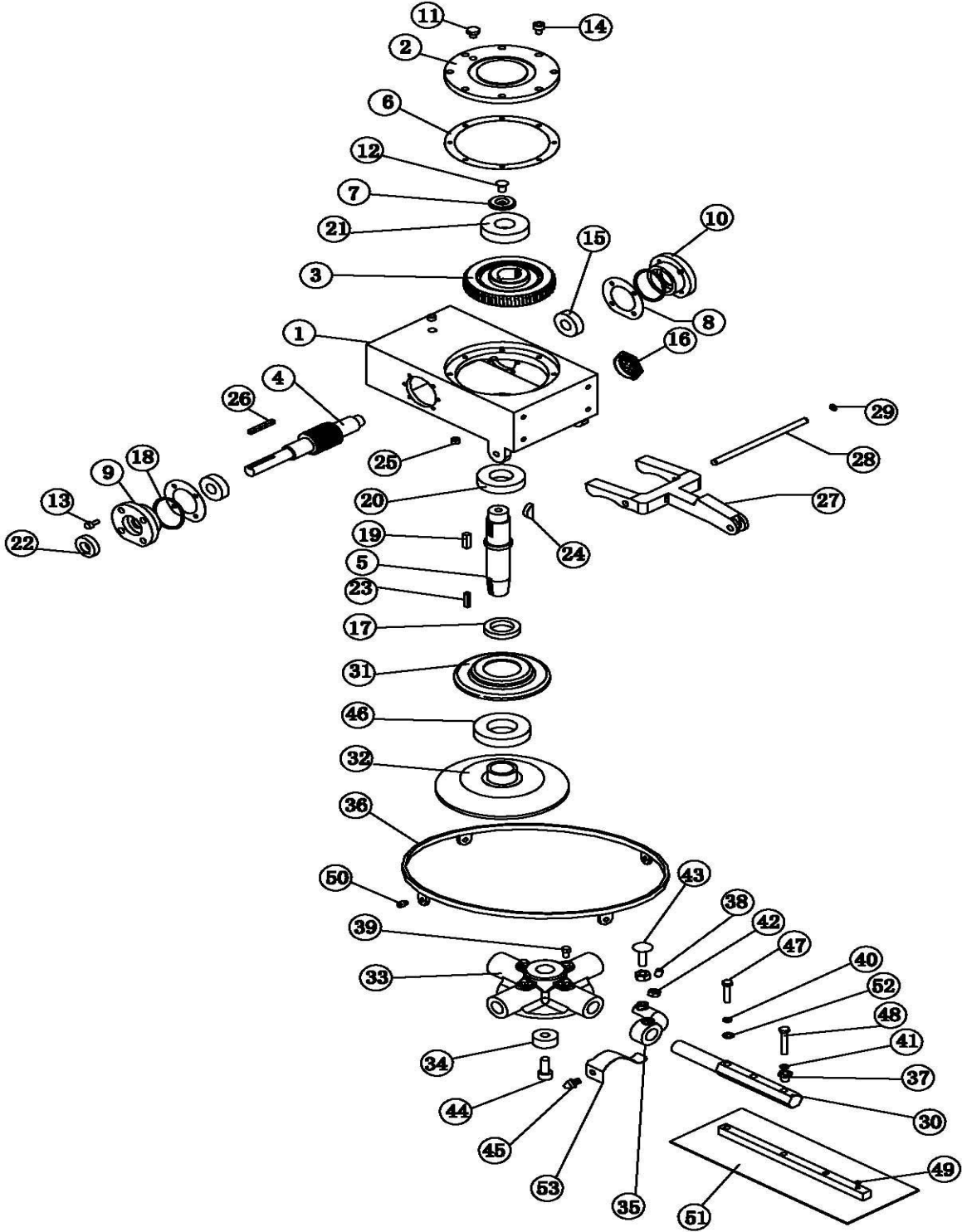

GEARBOX ASSY (L) PARTS LIST

Item No.	Part No.	Description	Qty.
1	JG846A060001	GEARBOX CASING	1
2	JG846A060003	GEARBOX COVER	1
3	JG846A060100	BRONZE GEAR	1
4	JG846A060009	COUNTER SHAFT	1
5	JG846A060005	MAIN SHAFT	1
6	JG846A060011	SHIMMING	1
7	JG846A060004	PRESSING RING	1
8	JG846A060012	SHIMMING	2
9	JG846A060007	FLANGE RIGHT	1
10	JG846A060008	FLANGE LEFT	1
11	4364100	REALSE VAVLE	2
12	4364007	SCREW	1
13	9043	SCREW	12
14	9118	SCREW	8
15	9466	BALL BEARING	2
16	9064	OIL VIEWER	1
17	9366	SEAL	1
18	9367	SEAL	2
19	9708	KEY	1
20	9468	BALL BEARING	1
21	9467	BALL BEARING	1
22	9368	SEAL	1
23	9710	KEY	1
24	9156	KEY	1
25	9053	PLUG	2
26	9709	KEY	1
27	JG846A050003	YOKE ARM	1
28	JG846A050002	YOKE ARM SHAFT	1
29	9202	SPLIT WASHER	2

GEARBOX ASSY (L) PARTS LIST cont.

Item No.	Part No.	Description	Qty.
30	JG846A070001	TROWEL ARM	4
31	JG846A070002	PRESSURE PLATE CAP	1
32	JG846A070003	PRESSURE PLATE	1
33	JG846A070004	SPIDER PLATE	1
34	JG846A070006	BUSHING	1
35	4466006	ANGLE ARM	4
36	44661031	STABILZING RING	1
37	4366007	ADJUST BUSHING	4
38	9540	SCREW	4
39	9066	BOLT	4
40	9037	WASHER	8
41	9046	WASHER	4
42	9059	NUT	8
43	9067	BOLT	4
44	9068	SCREW	1
45	9069	GREASE FITTING	4
46	9469	BALL BEARING	1
47	9071	BOLT	8
48	9131	BOLT	4
49	9072	PLUG	4
50	9147	SCREW	4
51	4466100Y	TROWEL BLADE	4
52	9038	WASHER	8
53	JG8366007L	RETURN SPRING	4

2.4 Gearbox Assembly (Right)

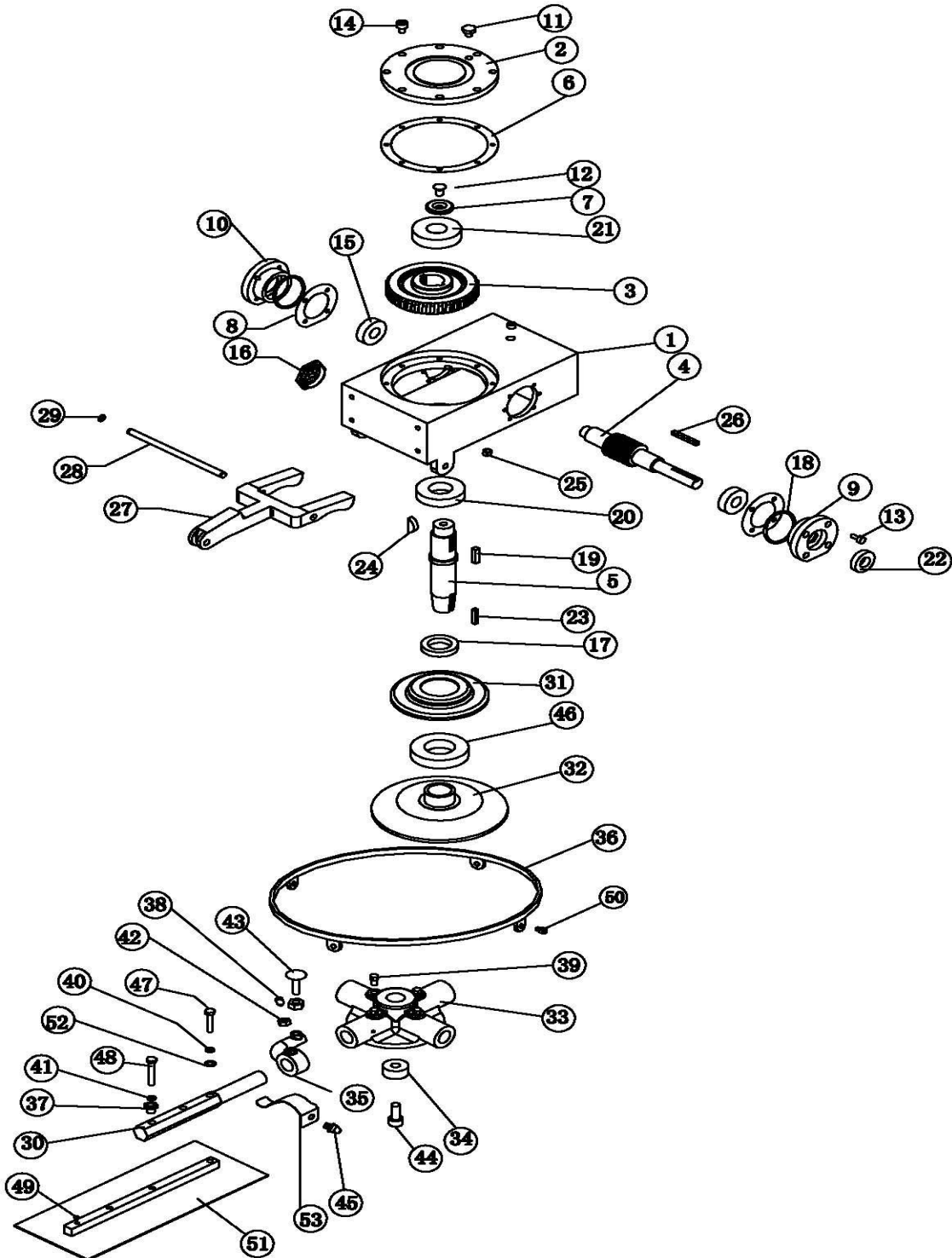

GEARBOX ASSY (R) PARTS LIST

Item No.	Part No.	Description	Qty.
1	JG846A060002	GEARBOX CASING	1
2	JG846A060003	GEARBOX COVER	1
3	JG846A060200	BRONZE GEAR	1
4	JG846A060010	COUNTER SHAFT	1
5	JG846A060006	MAIN SHAFT	1
6	JG846A060011	SHIMMING	1
7	JG846A060004	PRESSING RING	1
8	JG846A060012	SHIMMING	2
9	JG846A060007	FLANGE LEFT	1
10	JG846A060008	FLANGE RIGHT	1
11	4364100	RELEASE VAVLE	2
12	4364007	SCREW	1
13	9043	SCREW	12
14	9118	SCREW	8
15	9466	BALL BEARING	2
16	9064	OIL VIEWER	1
17	9366	SEAL	1
18	9367	SEAL	2
19	9708	KEY	1
20	9468	BALL BEARING	1
21	9467	BALL BEARING	1
22	9368	SEAL	1
23	9710	KEY	1
24	9156	KEY	1
25	9053	PLUG	2
26	9709	KEY	1
27	JG846A050003	YOKE ARM	1
28	JG846A050002	YOKE ARM SHAFT	1
29	9202	SPLIT WASHER	2

GEARBOX ASSY (R) PARTS LIST cont.

Item No.	Part No.	Description	Qty.
30	JG846A070001	TROWEL ARM	4
31	JG846A070002	PRESSURE PLATE CAP	1
32	JG846A070003	PRESSURE PLATE	1
33	JG846A070005	SPIDER PLATE	1
34	JG846A070006	BUSHING	1
35	8366006	ANGLE ARM	4
36	44661031	STABILIZING RING	1
37	4366007	ADJUST BUSHING	4
38	9540	SCREW	4
39	9066	BOLT	4
40	9037	WASHER	8
41	9046	WASHER	4
42	9059	NUT	8
43	9067	SCREW	4
44	9068	SCREW	1
45	9069	GREASE FITTING	4
46	9469	BALL BEARING	1
47	9071	BOLT	8
48	9131	BOLT	4
49	9072	PLUG	4
50	9147	SCREW	4
51	4466100Y	TROWEL BLADE	4
52	9038	WASHER	8
53	JG8366007L	RETURN SPRING	4

2.4 Fuel & Water System

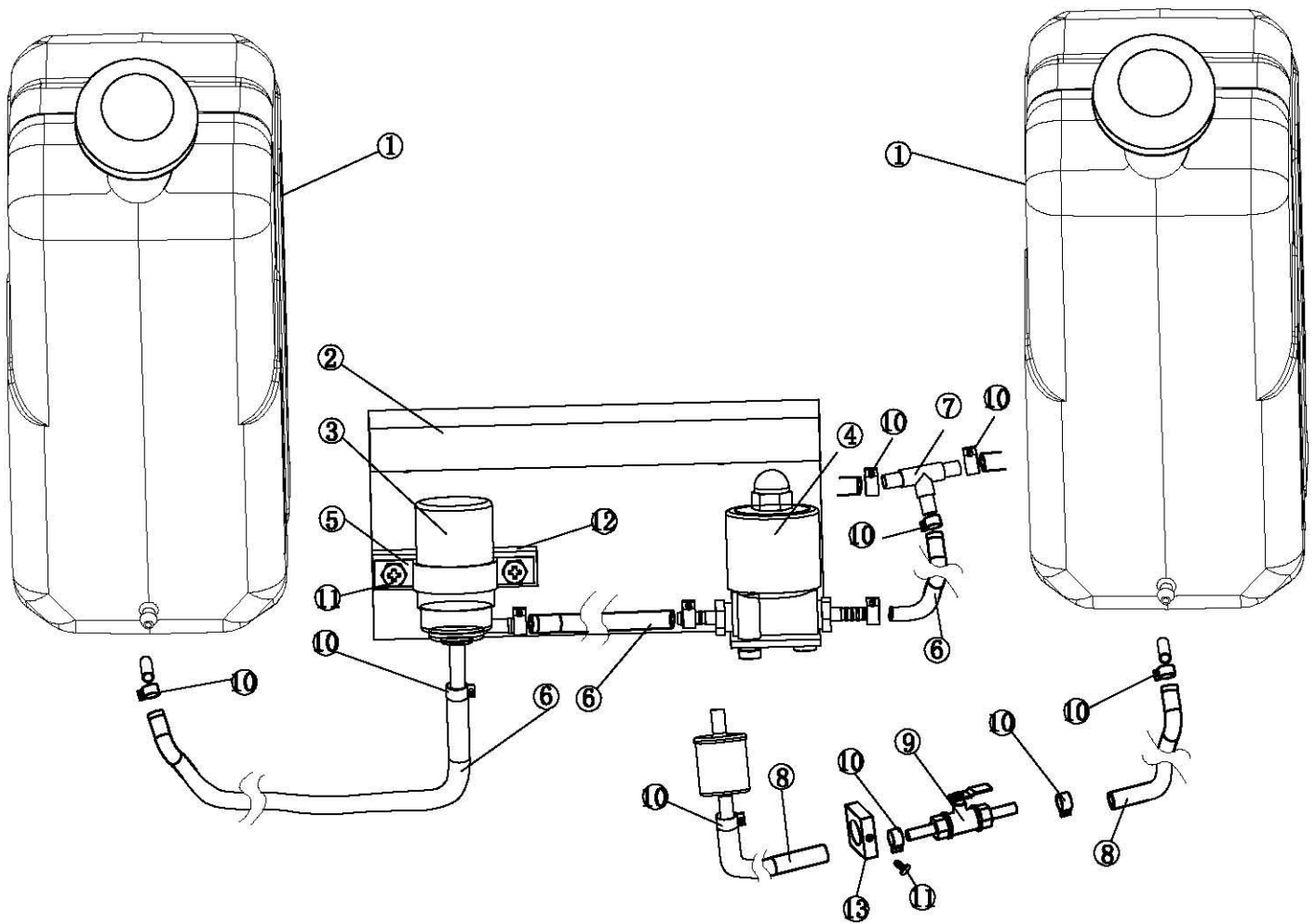



FUEL & WATER SYSTEM PARTS LIST

Item No.	Part No.	Description	Qty.
1	B8360715	FUEL/WATER TANK	2
2	8361067	WATER PUMP	1
3	8361144	HOOP	1
4	9010	BOLT	2
5	B8360731	MOUNTING PLATE	1
6	8360754	WATER PIPE	1
7	8361142	SOLENOID VALVE	1
8	8360589	FUEL PIPE	1
9	8361476	FUEL VALVE	1
10	8361071	HOOP	12