



SPARE PARTS MANUAL

FLEXTOOL PORTAPAC[®] FCP-48



Applies to product after Serial Number F01-10000

Version 1.0 (February 2022)

FOR MORE INFORMATION
CONTACT US ON **1300 353 986** OR VISIT flextool.com.au

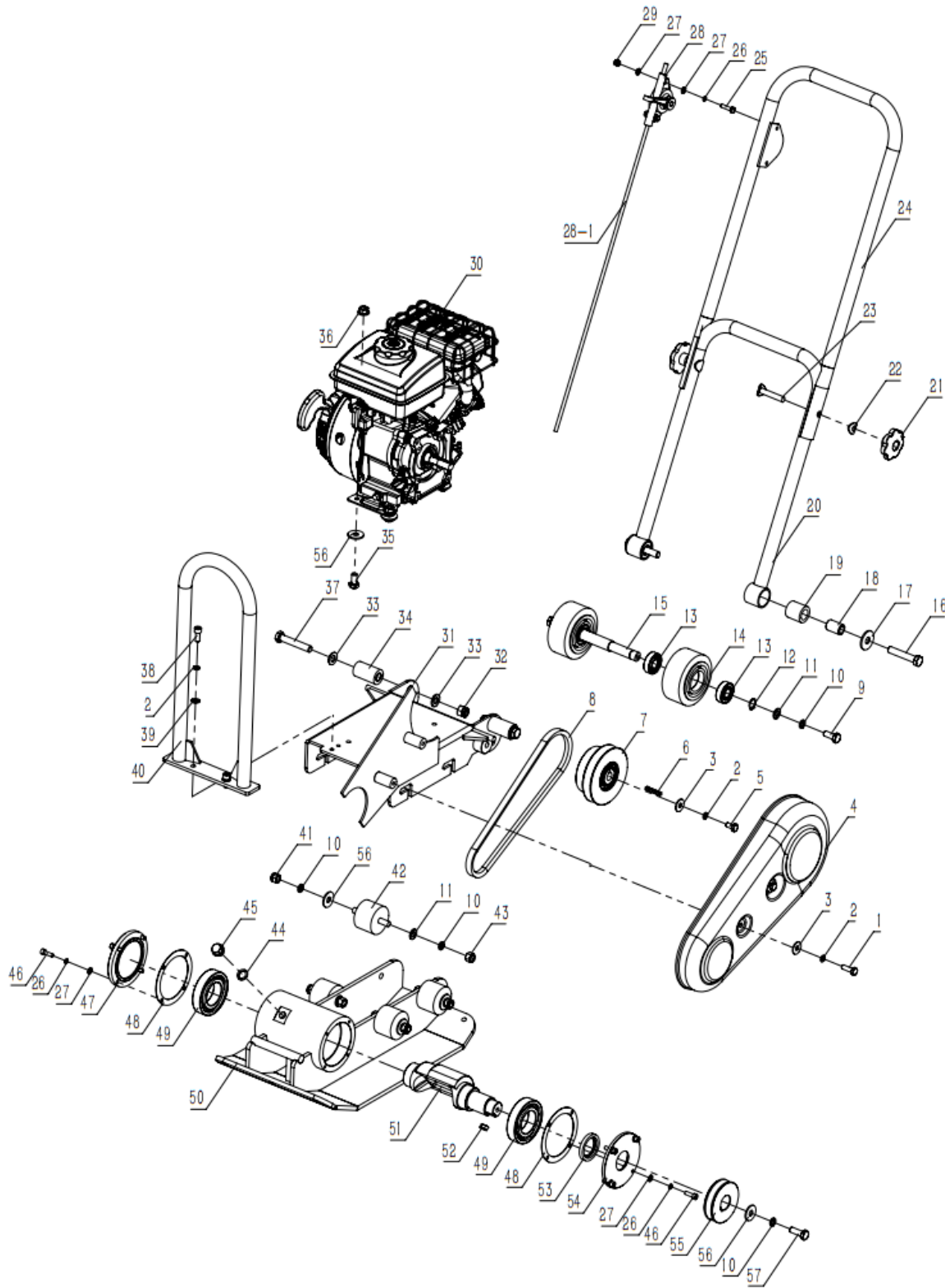

Item No.	Product Code	Description	Qty	Remarks
1	NPS01840-UNIT	FLX BOLT M8 X 25MM HEX (CNP50C001)	2	
2	NPS01371-UNIT	FLX SPRING WASHER 8MM (CNP2000012 / CNP200002)	5	
3	NPS01384-UNIT	FLX FLAT WASHER 8MM (MUDGUARD) (CNP200016 / CNP200003)	3	
4	NPS01868-UNIT	FLX BELT COVER FCP-48 (CNP50C004)	1	
5	NPS01841-UNIT	FLX BOLT M8 X 16MM HEX (CNP50C005)	1	
6	NPS01837-UNIT	FLX KEY 5MM X 35MM (CNP50C006)	1	
7	NPS01873-UNIT	FLX CLUTCH ASSY FCP-48 (CNP50C007)	1	
8	NPS01859-UNIT	FLX V-BELT 13X725-LI FCP-48 (CNP50C008)	1	
9	NPS01842-UNIT	FLX BOLT M10 X 25MM HEX (CNP50C009)	2	
10	NPS01373-UNIT	FLX SPRING WASHER 10MM (CNP200029 / CNP200019)	11	
11	NPS01374-UNIT	FLX FLAT WASHER 10MM (CNP200030 / CNP200022)	6	
12	NPS01843-UNIT	FLX CIRCLIP 17MM (CNP50C012)	2	
13	NPS01844-UNIT	FLX BEARING 6203-RZ (CNP50C013)	4	
14	NPS01860-UNIT	FLX WHEEL (W/O BEARINGS) (CNP50C014)	2	
15	NPS01865-UNIT	FLX WHEEL AXLE (CNP50C015)	1	
16	NPS01852-UNIT	FLX BOLT M12 X 65MM HEX (CNP50C016)	2	
17	NPS01845-UNIT	FLX FLAT WASHER 12MM (MUDGUARD) (CNP50C017)	2	
18	NPS01854-UNIT	FLX HANDLE BUSH SLEEVE (CNP50C018)	2	
19	NPS01846-UNIT	FLX HANDLE RUBBER BUSH (CNP50C019)	2	
20	NPS01869-UNIT	FLX HANDLE LOWER FCP-48 (CNP50C020)	1	
21	NPS01855-UNIT	FLX PALM NUT (CNP50C021)	2	
22	NPS01847-UNIT	FLX WAVE WASHER M10 (CNP50C022)	2	
23	NPS01857-UNIT	FLX HANDLE BOLT WAVE HEAD (CNP50C023)	2	
24	NPS01866-UNIT	FLX HANDLE UPPER FCP-48 (CNP50C024)	1	
25	NPS01390-UNIT	FLX BOLT M6 X 30MM (CNP200042-7)	2	
26	NPS01370-UNIT	FLX SPRING WASHER 6MM (CNP200027-14)	10	
27	NPS01836-UNIT	FLX FLAT WASHER 6MM (CNP50C027)	12	
28	NPS90043-UNIT	FLX THROTTLE LEVER FCP COMPACTORS (CNP200042-9)	1	
28-1	NPS01858-UNIT	FLX THROTTLE CABLE FCP-48 (CNP50C028-1)	1	
29	NPS01380-UNIT	FLX LOCK NUT 6MM FLX LOCK NUT 6MM (CNP200042-10)	2	
30		HON ENGINE GX100T-SE	1	
31	NPS01871-UNIT	FLX ENGINE MOUNTING FRAME (CNP50C031)	1	
32	NPS01838-UNIT	FLX NUT NYLOCK 12MM (CNP50C032)	2	
33	NPS01378-UNIT	FLX FLAT WASHER 12MM (CNP200026)	4	
34	NPS01856-UNIT	FLX RUBBER HANDLE STOPPER (CNP50C034)	2	
35	NPS01389-UNIT	FLX BOLT M10 X 20MM HEX (CNP200028)	4	
36	NPS01387-UNIT	FLX LOCK NUT 10MM (CNP200023 / CNP200018)	4	
37	NPS01853-UNIT	FLX BOLT M12 X 70MM HEX (CNP50C037)	2	
38	NPS01385-UNIT	FLX BOLT M8 X 20MM SOCKET HEAD (CNP200006)	2	
39	NPS01372-UNIT	FLX FLAT WASHER 8MM (CNP200043-3 / CNP200008)	2	
40	NPS01870-UNIT	FLX LIFTING HOOK FCP-48 (CNP50C040)	1	
41	NPS01387-UNIT	FLX LOCK NUT 10MM (CNP200023 / CNP200018)	4	
42	NPS01398-UNIT	FLX RUBBER MOUNT (CNP200021)	4	
43	NPS01387-UNIT	FLX LOCK NUT 10MM (CNP200023 / CNP200018)	4	
44	NPS01848-UNIT	FLX GASKET WASHER 14MM (CNP50C044)	1	
45	NPS01849-UNIT	FLX OIL PLUG M14 X 11MM (CNP50C045)	1	
46	NPS01850-UNIT	FLX BOLT M6 X 20MM SOCKET HEAD (CNP50C046)	8	
47	NPS01861-UNIT	FLX FLANGE COVER (CNP50C047)	1	
48	NPS01851-UNIT	FLX GASKET (CNP50C048)	1	
49	NPS01867-UNIT	FLX BEARING 6209 (CNP50C049)	2	
50	NPS01874-UNIT	FLX BASE PLATE ASSY FCP-48 (CNP50C050)	1	
51	NPS01872-UNIT	FLX ECCENTRIC SHAFT (CNP50C051)	1	
52	NPS01839-UNIT	FLX KEY 8MM X 16MM (CNP50C052)	1	
53	NPS01400-UNIT	FLX OIL SEAL 35MM X 52MM X 7MM (CNP200027-07)	1	
54	NPS01862-UNIT	FLX FLANGE COVER (OUTPUT SIDE) (CNP50C054)	1	
55	NPS01863-UNIT	FLX PULLEY FCP-48 (CNP50C055)	1	
56	NPS01388-UNIT	FLX FLAT WASHER 10MM (MUDGUARD) (CNP200020)	9	



Parchem Construction Supplies Pty Ltd

1956 Dandenong Road, Clayton VIC 3168, Australia

Phone: 1300 353 986

flextool.com.au

ABN 80 069 961 968

This manual summarises our best knowledge of the product based on the information available at the time of publication. You should read this manual carefully and consider the information in the context of how the product will be used. Our responsibility for products sold is subject to our standard terms and conditions of sale.

DISCLAIMER:

Any advice, recommendation, information, assistance or service provided by us in this manual is given in good faith and is believed by us to be appropriate and reliable. However, any advice, recommendation, information, assistance or service provided by us is provided without liability or responsibility PROVIDED THAT the foregoing shall not exclude, limit, restrict or modify the right entitlements and remedies conferred upon any person or the liabilities imposed upon us by any condition or warranty implied by Commonwealth, State or Territory Act or ordinance void or prohibiting such exclusion limitation or modification. The product can be expected to perform as indicated in this manual so long as operation and operational procedures of the individual products are followed as recommended in this manual.

Design and technical specifications may be subject to changes.

© This publication is copyright. All rights are reserved. Flextool and PortaPac are registered trade marks of Parchem Construction Supplies Pty Ltd.

FOR MORE INFORMATION

CONTACT US ON 1300 353 986 OR VISIT flextool.com.au